

Friedrich

Room Air Conditioner Service and Parts Manual

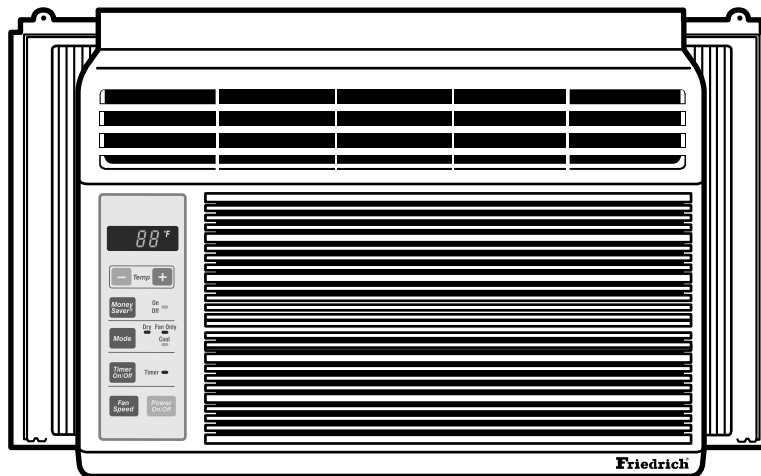

115Volts • CP05C10

CONTENTS

1. PREFACE	3
1.1 FEATURES.....	3
1.2 SPECIFICATIONS	3
1.3 LOCATIONS OF CONTROLS	4
1.4 SAFETY PRECAUTIONS	4
1.5 INSULATION RESISTANCE TEST	4
2. DISASSEMBLY INSTRUCTIONS	5
2.1 MECHANICAL PARTS	5
2.1.1 FRONT GRILLE	5
2.1.2 CABINET.....	5
2.1.3 CONTROL BOARD.....	5
2.2 AIR HANDLING PARTS	6
2.2.1 AIR GUIDE UPPER	6
2.2.2 ORIFICE, TURBO FAN AND FAN	6
2.2.3 MOTOR	7
2.2.4 AIR GUIDE.....	7
2.3 ELECTRICAL PARTS	7
2.3.1 OVERLOAD PROTECTOR	7
2.3.2 COMPRESSOR	8
2.3.3 CAPACITOR	8
2.3.4 THERMOSTAT	8
2.3.5 ROTARY SWITCH.....	8
2.3.6 POWER CORD	9
2.4 REFRIGERANT CYCLE	9
2.4.1 CONDENSER	9
2.4.2 EVAPORATOR	10
2.4.3 CAPILLARY TUBE	10
3. TROUBLESHOOTING GUIDE	12
3.1 OUTSIDE DIMENSIONS.....	12
3.2 PIPING SYSTEM	13
3.3 TROUBLESHOOTING GUIDE	14
4. CIRCUIT DIAGRAM	19
5. EXPLODED VIEW	20
6. SERVICE PARTS LIST	21

1. PREFACE

This service manual provides various service information, including the mechanical and electrical parts, etc. This room air conditioner was manufactured and assembled under a strict quality control system. The refrigerant is charged at the factory. Be sure to read the safety precautions prior to servicing the unit.

1.1 FEATURES

- DESIGNED FOR COOLING ONLY
- BUILT-IN ADJUSTABLE THERMOSTAT
- WASHABLE ONE-TOUCH FILTER
- COMPACT SIZE

1.2 SPECIFICATIONS

ITEMS \ MODELS	CP05C10
COOLING CAPACITY (BTU/h)	5,100
POWER SUPPLY (Phase, V, Hz)	1 \emptyset , 115V, 60HZ
INPUT (W)	520
OPERATING CURRENT (AMP.)	4.4
REFRIGERANT CONTROL	CAPILLARY TUBE
REFRIGERANT CHARGE (R-22)	330g (11.6 oz)
INSIDE FAN	TURBO FAN
OUTSIDE FAN	PROPELLER FAN WITH SLINGER RING
AIR DISCHARGE	2-WAY (RIGHT AND LEFT)
CHASSIS	TOP-DOWN
PROTECTOR	<ul style="list-style-type: none">• OVERLOAD PROTECTOR FOR COMPRESSOR• INTERNAL PROTECTOR FOR FAN MOTOR
TEMPERATURE CONTROL	THERMISTOR
FAN MOTOR	6 POLES, 21W

1.3 LOCATIONS OF CONTROLS

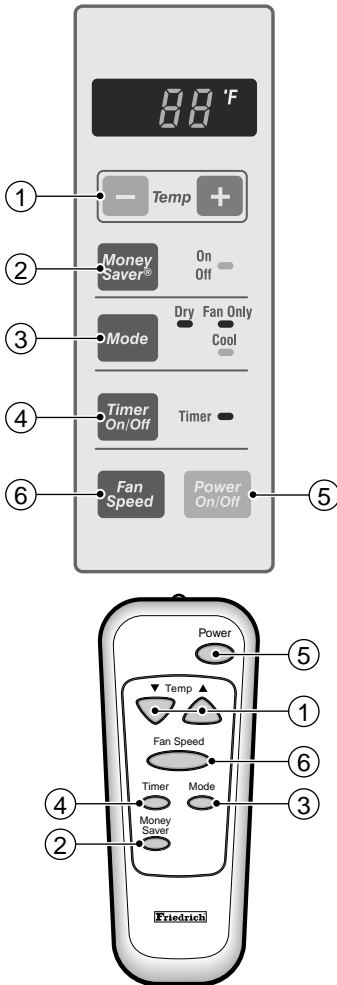

① TEMPERATURE SETTING

- These buttons control the temperature of the room.
The temperature can be set within a range of 60°F to 86°F, in increments of 1°F.

② MONEY SAVER

- The fan stops when the compressor stops cooling.
- Approximately every 3 minutes the fan will turn on and sample the room air to determine if more cooling is needed.

③ OPERATION MODE SELECTOR

- Everytime you push this button, it will rotate between the COOL, FAN and DRY modes.

④ ON/OFF TIMER

ON—When the air conditioner is off, it can be set to automatically come on in 1 to 12 hours from its previous setting. Each touch will increase the timer by 1 hour.

OFF—When the air conditioner is on, it can be set to automatically turn off in 1 to 12 hours. Each touch will increase the timer by 1 hour. After the timer has been on for 30 minutes, the temperature will automatically rise 2°F, and after another 30 minutes, it will automatically rise 2°F again. The temperature will then stay the same until the timer goes OFF.

To cancel the timer, press the TIMER pad until the display time disappears.

⑤ POWER

- To turn the unit ON, push the button. To turn the unit OFF, push the button again.
- This button takes priority over any other buttons.
- When you first turn it on, the unit is on the High cool mode and the temp. at 72°F

⑥ FAN SPEED

- Everytime you push this button it will rotate between the following fan speeds:
High (F3) → Low(F1) → Medium (F2) → High (F3)



2. DISASSEMBLY INSTRUCTIONS

2.1 MECHANICAL PARTS

2.1.1 FRONT GRILLE

1. Pull the inlet grille forward.
2. Remove the screw securing the Front Grille. (Fig. 3)
3. Push the grille up from the bottom and pull the top of the grille away from the case to lift the top tabs out of their slots. (Fig. 4)
4. Carefully position the grille, bottom first, and snap back into place.
5. Reposition the screw that secures the front grille

Figure 1

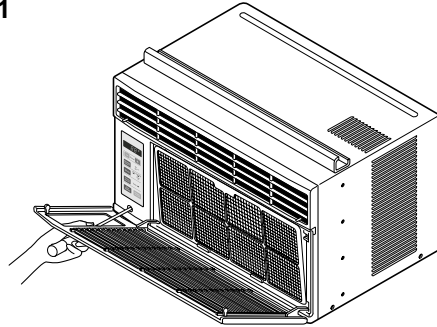

2.1.2 CABINET

1. Disconnect the unit from the power source.
2. Remove the front grille. (Refer to section 2.1.1)
3. Remove 9 screws that secure the cabinet to the base pan and condenser. (See Figure 3)
4. Lift the cabinet from the unit.
5. Re-install by referring to the procedures above.

Figure 2

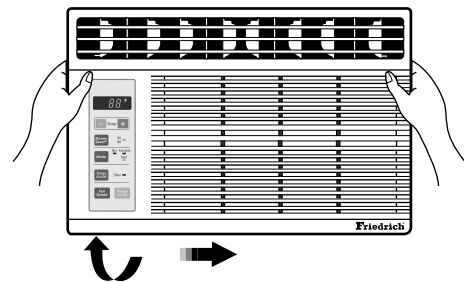

2.1.3 CONTROL PANEL

2. Remove the front grille. (Refer to Section 2.1.1)
3. Remove the cabinet. (Refer to Section 2.1.2)
4. Remove 1 screws that secure the control board to base pan and air guide. (See Figure 4)
5. Pull the control panel toward yourself.

Figure 3

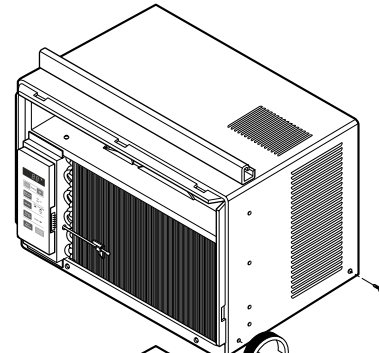

Figure 4

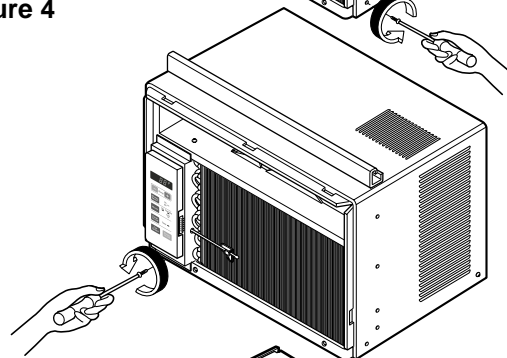
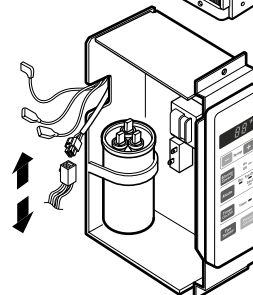

Figure 5



NOTE : Controls, wires, and capacitor are now accessible for servicing. Discharge the capacitor before servicing. See step 2.3.3 on page 8 for procedures.

- the fan motor and compressor. (See Figure 5)
7. Re-install components by referring to procedures above. (Refer to wiring diagram on page 23 in this manual or inside control board.)

2.2 AIR HANDLING PARTS

2.2.1 AIR GUIDE UPPER

1. Disconnect the unit from the power source.
2. Remove the front grille. (Refer to Section 2.1.1)
3. Remove the cabinet. (Refer to Section 2.1.2)
4. Remove the control panel.
(Refer to Section 2.1.3)
5. Remove 2 screws that secure the upper air guide to air guide lower. (See Figure 6)
6. Lift upper air guide upward.
7. Re-install by referring to the procedures above.

Figure 6

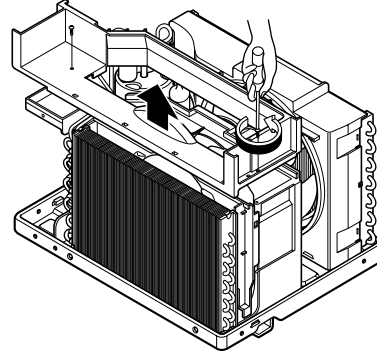

2.2.2 ORIFICE, TURBO FAN AND FAN

1. Disconnect the unit from the power source.
2. Remove the front grille. (Refer to Section 2.1.1)
3. Remove the cabinet. (Refer to Section 2.1.2)
4. Remove the control board.
(Refer to Section 2.1.3)
5. Remove the air guide upper.
(Refer to Section 2.2.1)
6. Remove 2 screws that secure the base pan to condenser. (See Figure 7)
7. Remove screw that secures the shroud to channel of condenser.
8. Press the snap area of shroud with your thumbs. This allows you to remove it from the condenser.
9. Lift the compressor upward with the evaporator and condenser. (See Figure 7)
10. Remove the orifice by pushing the snap area of the air guide blower. (See Figure 8)
11. Remove the clamp springs which are clamped to the shaft of fan and turbo fan by hand plier. (See Figure 9)
12. Pull the fan and turbo fan outward.
13. Remove the shroud.
14. Re-install by referring to the procedures above.

Figure 7

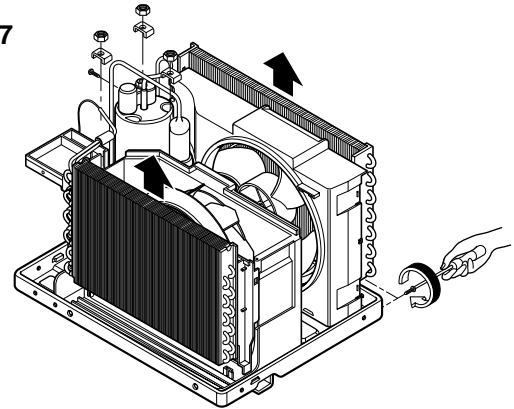

Figure 8

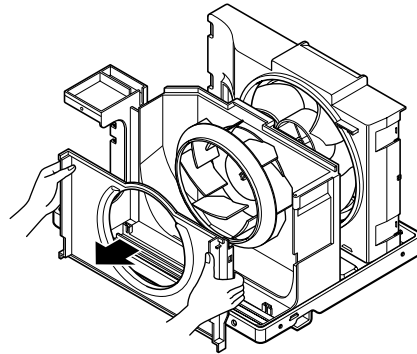
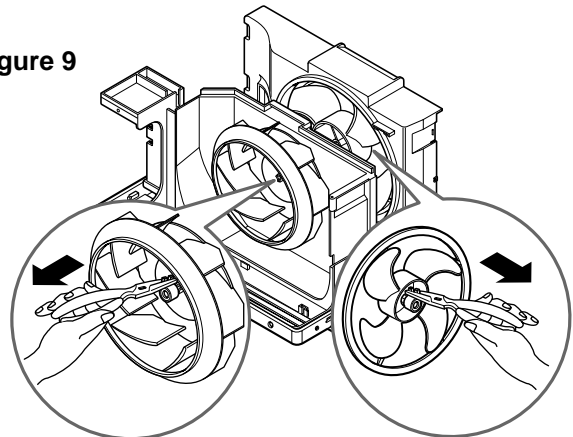

Figure 9



2.2.3 MOTOR

1. Disconnect the unit from the power source.
2. Remove the front grille. (Refer to Section 2.1.1)
3. Remove the cabinet. (Refer to Section 2.1.2)
4. Remove the control panel.
(Refer to Section 2.1.3)
5. Remove the upper air guide.
(Refer to Section 2.2.1)
6. Remove the compressor, turbo fan, fan and shroud. (Refer to Section 2.2.2)
7. Remove 2 screws that secure the motor to the motor mount . (See Figure 10)
8. Remove the motor.
9. Re-install by referring to the procedures above.

Figure 10

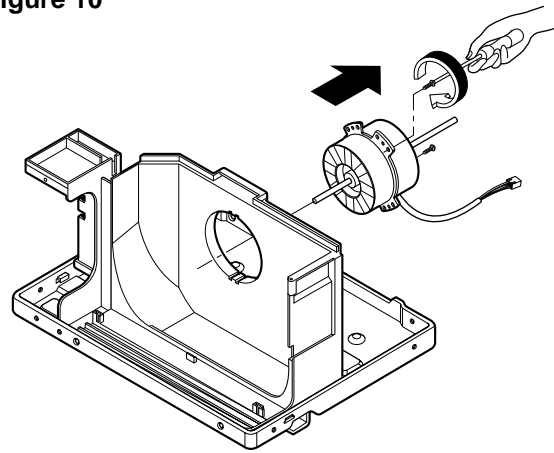

2.2.4 AIR GUIDE

1. Disconnect the unit from the power source.
2. Remove the front grille. (Refer to Section 2.1.1)
3. Remove the cabinet. (Refer to Section 2.1.2)
4. Remove the control panel.
(Refer to Section 2.1.3)
5. Remove the upper air guide .
(Refer to Section 2.2.1)
6. Remove the compressor, turbo fan, fan and shroud. (Refer to Section 2.2.2)
7. Remove the motor. (Refer to Section 2.2.3)
8. Remove 2 screws that secure the air guide to the base pan. (See Figure 11)
9. Push the air guide backward and lift it upward.
(See Figure 11)
10. Re-install by referring to the procedures above.

Figure 11

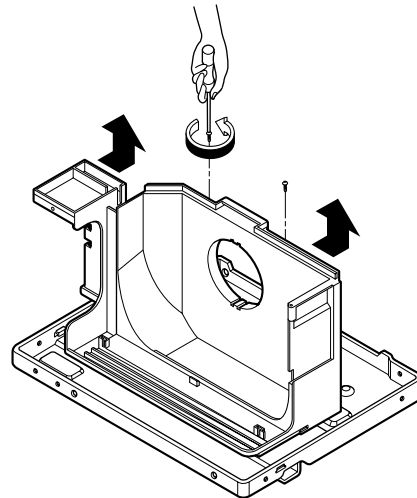

2.3 ELECTRICAL PARTS

2.3.1 OVERLOAD PROTECTOR

1. Remove the front grille and cabinet.
(Refer to Section 2.1)
2. Remove the nut which fastens the terminal cover.
3. Remove the terminal cover.
4. Remove all the leads from the overload protector.
5. Remove the overload protector.
6. Re-install the components by referring to the removal procedure above.
(See Figure 12 and 13)

Figure 12

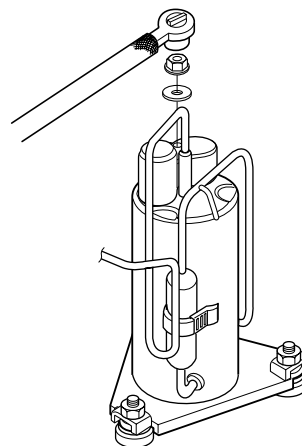
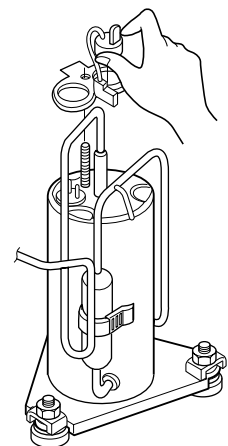

Figure 13



2.3.2 COMPRESSOR

1. Remove the front grille and cabinet.
(Refer to Section 2.1)
2. Discharge the refrigerant by using a refrigerant recovery system.
3. Remove the overload protector.
(Refer to Section 2.3.1)
4. After discharging the unit completely, unbrace the suction and discharge pipes at the compressor connections.
5. Remove 3 nuts which fasten the compressor.
6. Remove the compressor.
7. Re-install by referring to the removal procedure above. (See Figure 14)

Figure 14

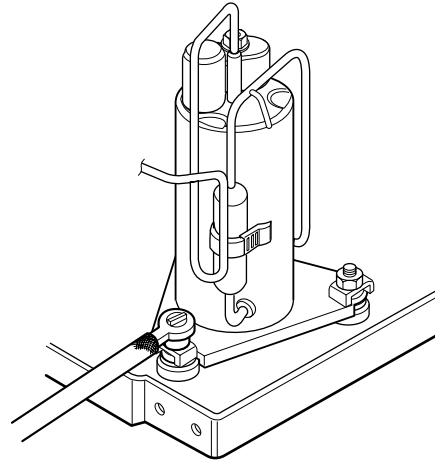

2.3.3 CAPACITOR

1. Remove the cabinet. (Refer to Section 2.1.2)
2. Remove the control panel.
(Refer to Section 2.1.3)
3. Discharge the capacitor by placing a 20 K Ω resistor across the capacitor terminals.
4. Remove the screw which fastens the capacitor clamp.
5. Remove all the leads of capacitor terminals.
6. Re-install the components by referring to the removal procedure above. (See Figure 15)

Figure 15

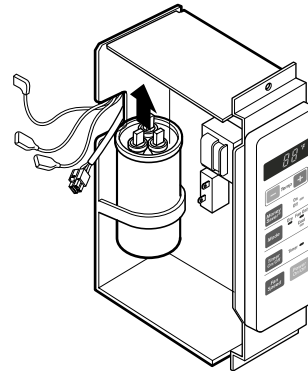

2.3.4 THERMISTOR

1. Remove the cabinet. (Refer to Section 2.1.2)
2. Remove the control panel.
(Refer to Section 2.1.3)
3. Disconnect the thermistor terminals from main P.W.B assembly.
4. Remove the thermistor.
5. Re-install the components by referring to the removal procedure above. (See Figure 16)

Figure 16

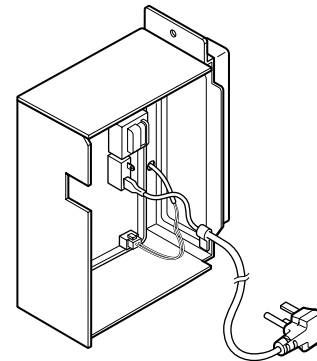

2.3.5 CONTROL BOARD

1. Remove the cabinet. (Refer to Section 2.1.2)
2. Remove the control panel.
(Refer to Section 2.1.3)
3. Pull the control board forward and pull out it.
4. Remove 2 lead wire terminals.
5. Re-install the components by referring to the removal procedure above. (See Figure 17)

Figure 17

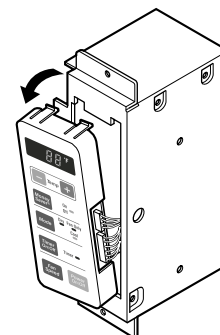

2.3.6 POWER CORD

1. Disconnect the unit from source of power.
2. Remove the front grille. (Refer to Section 2.1.1)
3. Remove the cabinet. (Refer to Section 2.1.2)
4. Remove a screw that secures control panel to base pan. (Refer to Section 2.1.3)
5. Pulls the control board toward you.
6. Disconnect the 2 receptacles and remove the grounding screw.
7. Remove a screw securing the clip with cord to the control panel.
8. Pull the power cord.
9. Re-install by referring to procedures above.

Figure 18

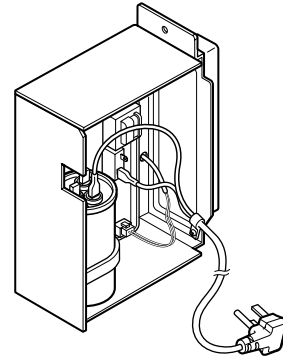

2.4 REFRIGERANT CYCLE

2.4.1 CONDENSER

1. Remove the cabinet. (Refer to Section 2.1.2)
2. Discharge the refrigerant by using a refrigerant recovery system.
3. Remove the air guide. (Refer to Section 2.2.1)
4. Remove 2 screws which fasten the condenser.
5. After discharging the refrigerant completely, unbraid the interconnecting tube at the condenser connections.
6. Remove the condenser.
7. Re-install by referring to the procedures above.

Figure 19

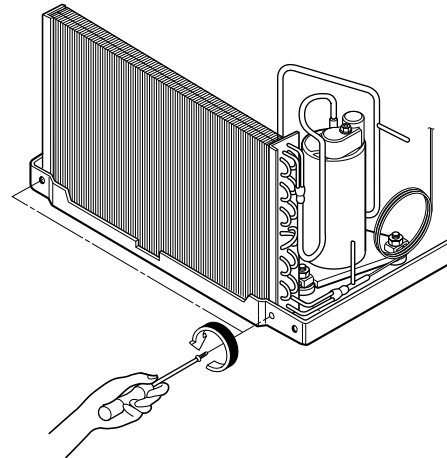

2.4.2 EVAPORATOR

1. Remove the cabinet.
2. Discharge the refrigerant by using a refrigerant recovery system.
3. Remove the upper air guide . (Refer to Section 2.2.1)
4. After discharging the refrigerant completely, unbrazed the interconnecting tube at the condenser connections.
5. Remove the evaporator.
6. Re-install by referring to the procedures above.

2.4.3 CAPILLARY TUBE

1. Remove the cabinet.
2. Discharge the refrigerant by using a refrigerant recovery system.
3. Remove the upper air guide. (Refer to Section 2.2.1)
4. After discharging the refrigerant completely, unbrazed the interconnecting tube of the capillary tube.
5. Remove the capillary tube.
6. Re-install by referring to the procedures above.

NOTES

Replacement of the refrigeration cycle.

1. When replacing the refrigerating cycle, be sure to discharge the refrigerant by using a refrigerant recovery system.
2. After discharging the unit completely, remove the desired components, and unbrazed the pinch-off tubes.
3. Solder service valves into the pinch-off tube ports, leaving the valves open.
4. Solder the pinch-off tubes with service valves.
5. After completing the above procedures, the valve must be removed .
6. Evacuate as follows:
 - 6-1. Connect the vacuum pump, as illustrated in figure 21A.
 - 6-2. Start the vacuum pump. Slowly open manifold valves A and B with two full turns counter-clockwise and leave the valves closed. The vacuum pump is now pulling through valves A and B up to valve C by means of manifold and the entire system.

CAUTION : If high vacuum equipment is used, just crack valves A and B for a few minutes, then open slowly with the two full turns counter-clock-

wise. This will keep oil from foaming and being drawn into the vacuum pump.

- 6-3. Operate the vacuum pump for 20 to 30 minutes, until 600 micron vacuum is obtained. Close valves A and B and observe vacuum gauge for a few minutes. A rise in pressure would indicate a possible leak or moisture remaining in the system. With valves A and B closed, stop the vacuum pump.
- 6-4. Remove the hose from the vacuum pump and place it on the charging cylinder. See figure 23B. Open valve C. Discharge the line at the manifold connection.
- 6-5. The system is now ready for final charging.
7. Recharge as follows:
 - 7-1. Rotary compressor systems are charged from the high-side. If the total charge cannot be put in the high-side, the balance will be put in the suction line through the access valve which is installed as the system is opened.
 - 7-2. Connect the charging cylinder as shown in figure 21B. With valve C open, discharge the hose at the manifold connection.
 - 7-3. Open valve A and allow the proper charge to enter the system. Valve B is still closed.
 - 7-4. If more charge is required, the high-side will not take it. Close valve A.
 - 7-5. With the unit running, open valve B and add the balance of the charge.
 - a. Do not add the liquid refrigerant to the low-side.
 - b. Watch the low-side gauge, allow pressure to rise to 30 lbs.
 - c. Turn off valve B and allow the pressure to drop.
 - d. Repeat steps B and C until the balance of the charge is in the system.
 - 7-6. When the unit is operating correctly, use the pinch-off tool with the unit still running and the clamp on the pinch-off tube. Using a tube cutter, cut the pinch-off tube about 2 inches from the pinch-off tool. Use sil-fos solder and solder the pinch-off tube closed. Turn off the unit, allow setting for a while and then test the leakage of the pinch-off connection.

Equipment needed: Vacuum pump, charging cylinder, manifold gauge, brazing equipment, pinch-off tool capable of making a vapor proof seal, leak detector, tubing cutter, hand tools to remove components and service valve.

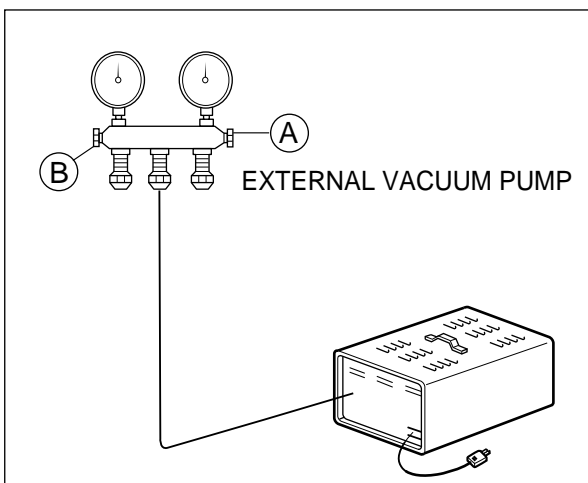
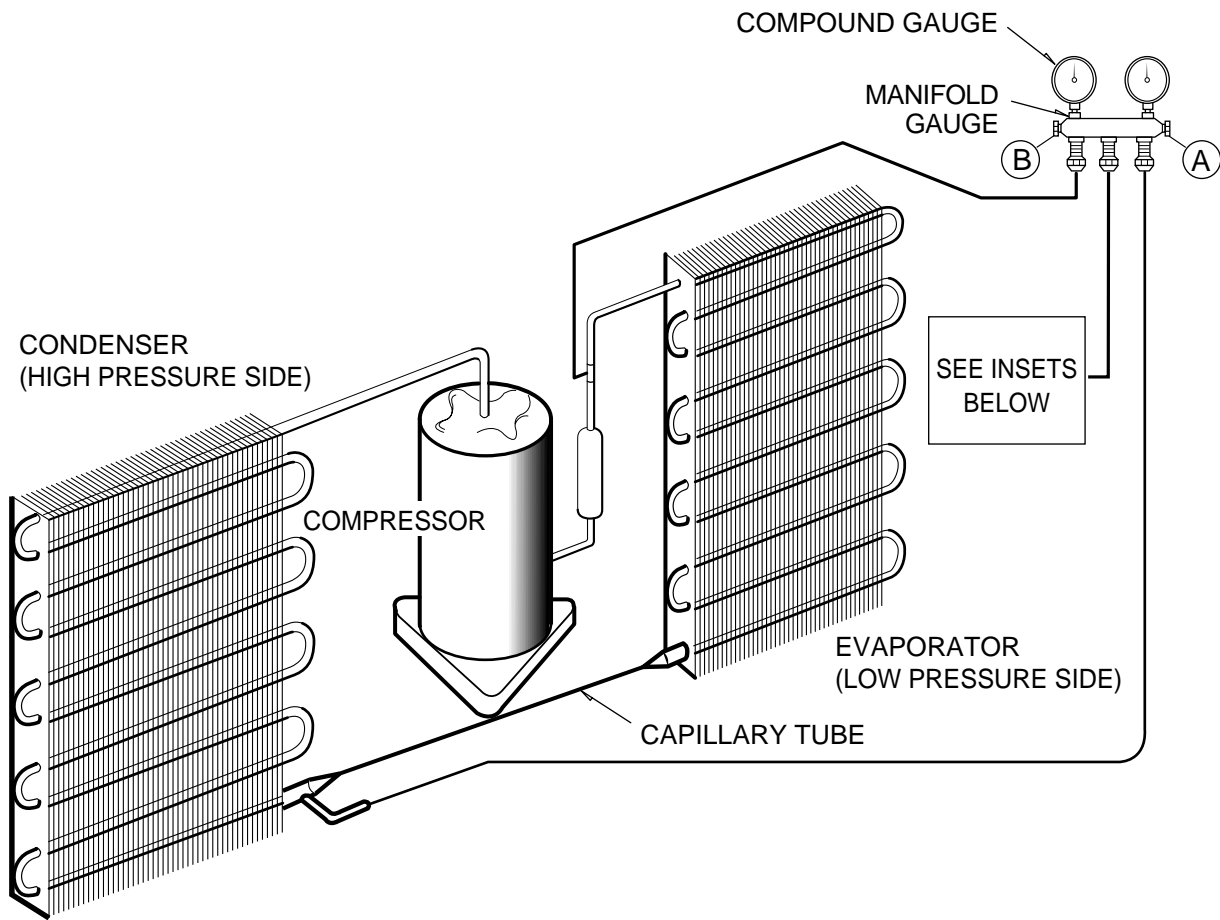

Figure 21A-Pulling Vacuum

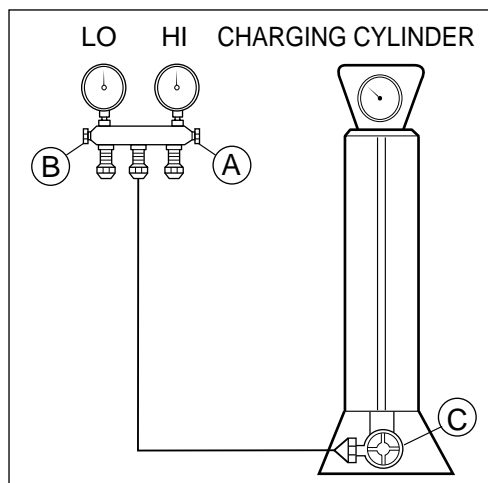
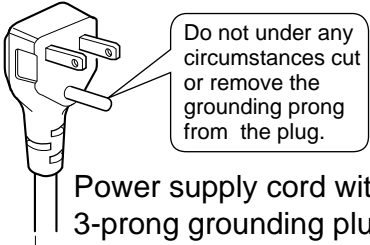
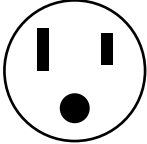

Figure 21B-Charging

2.4.4 ELECTRICAL DATA

Line Cord Plug	Use Wall Receptacle	Power Supply
 <p>Do not under any circumstances cut or remove the grounding prong from the plug.</p> <p>Power supply cord with 3-prong grounding plug</p>	 <p>Standard 125V, 3-wire grounding receptacle rated 15A, 125V AC</p>	<p>Use 15 AMP, time delay fuse, or circuit breaker.</p>

USE OF EXTENSION CORDS

Because of potential safety hazards, we strongly discourage the use of an extension cord. However, if you wish to use an extension cord, use a CSA certified/UL-listed 3-wire (grounding) extension cord, rated 15A, 125V.

3. TROUBLESHOOTING GUIDE

3.1 OUTSIDE DIMENSIONS (unit: mm [in])

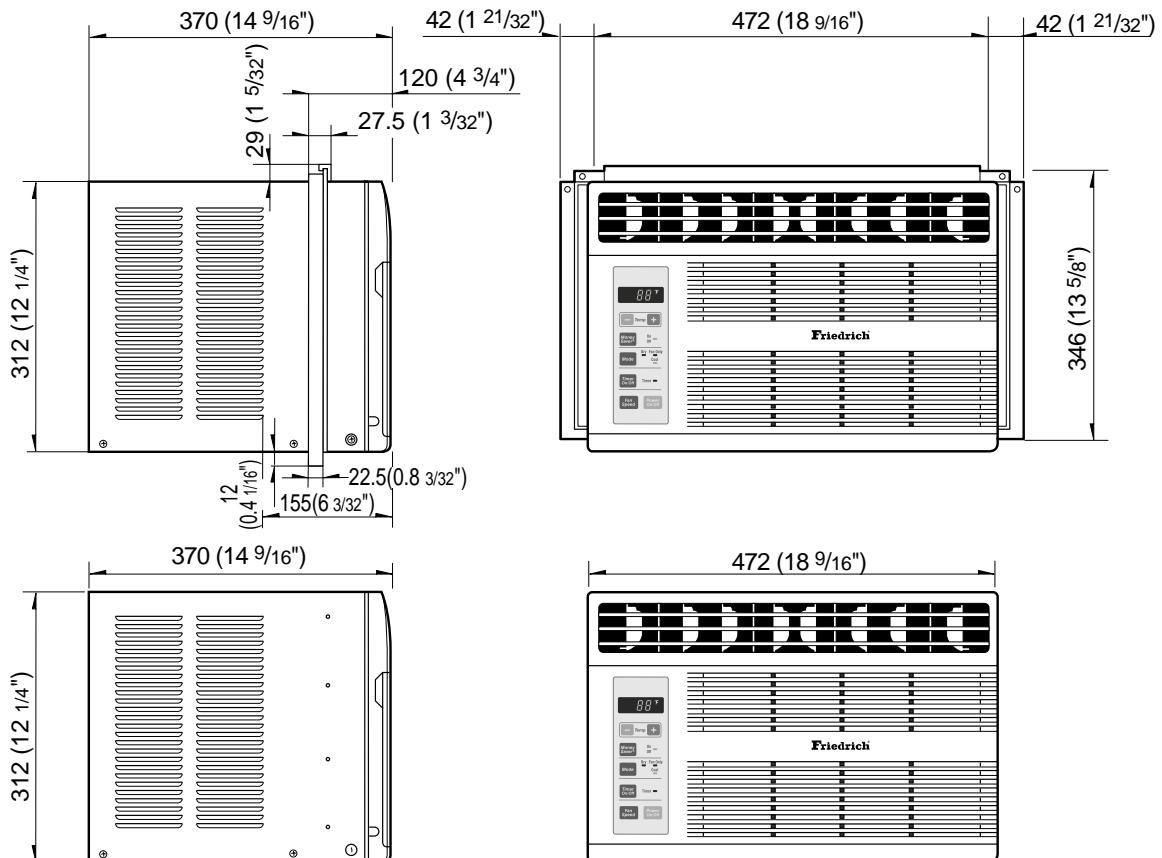

3.2 PIPING SYSTEM

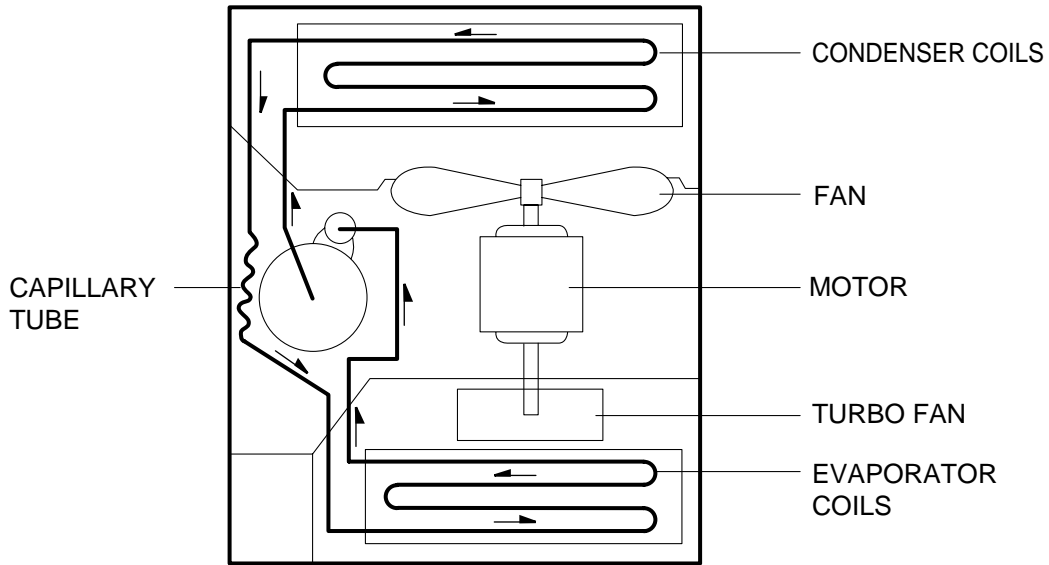

Following is a brief description of the important components and their function in what is called the refrigeration system. Reference should be made to Figure 32 to follow the refrigerating cycle and the flow of the refrigerant in the cooling cycle.

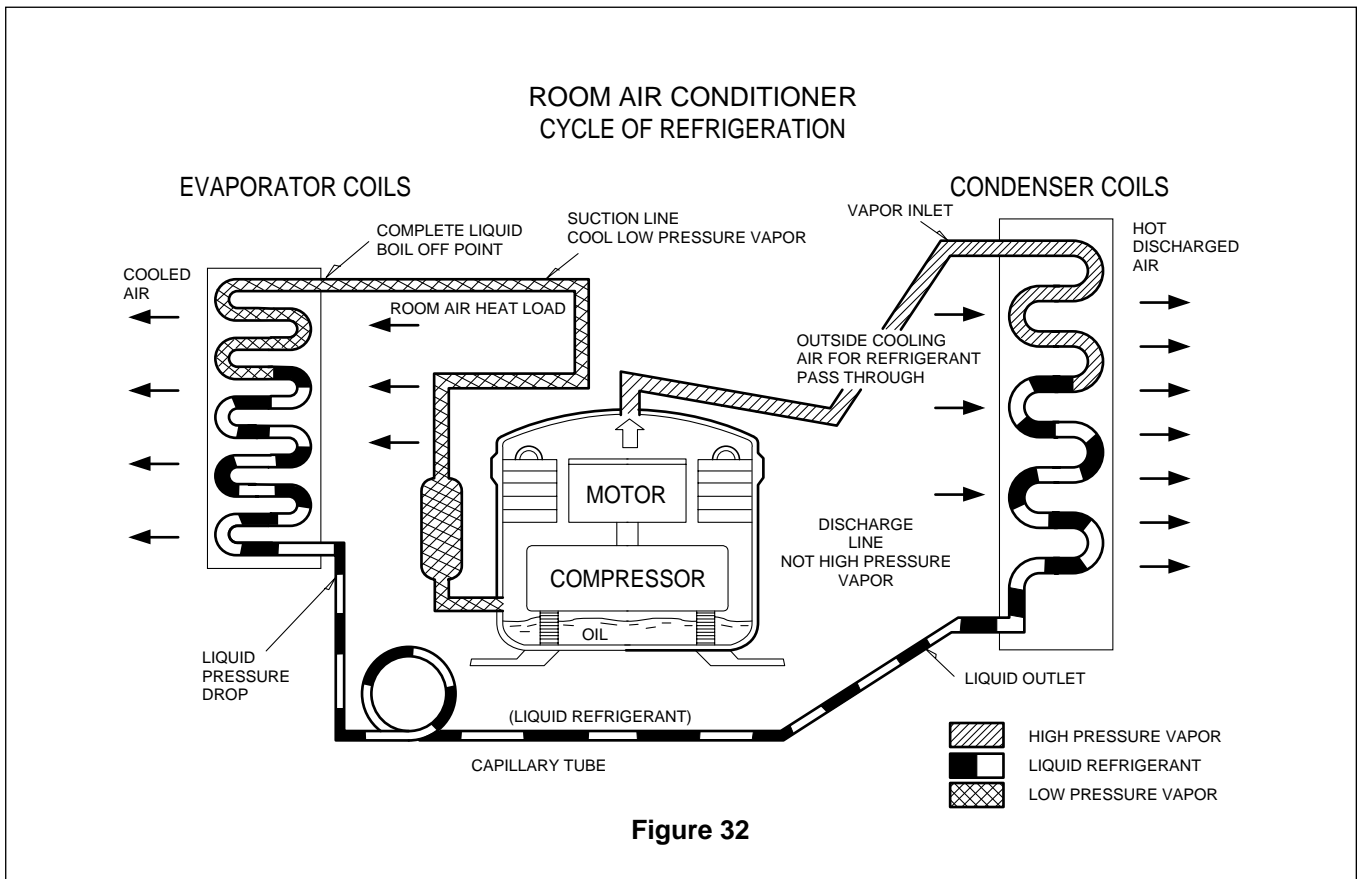

3.3 TROUBLESHOOTING GUIDE

In general, possible trouble is classified in two kinds.

The one is called **Starting Failure** which is caused by an electrical defect. The other is **Ineffective Air Conditioning** caused by a defect in the refrigeration circuit and improper application.

Unit is running but cooling is ineffective.

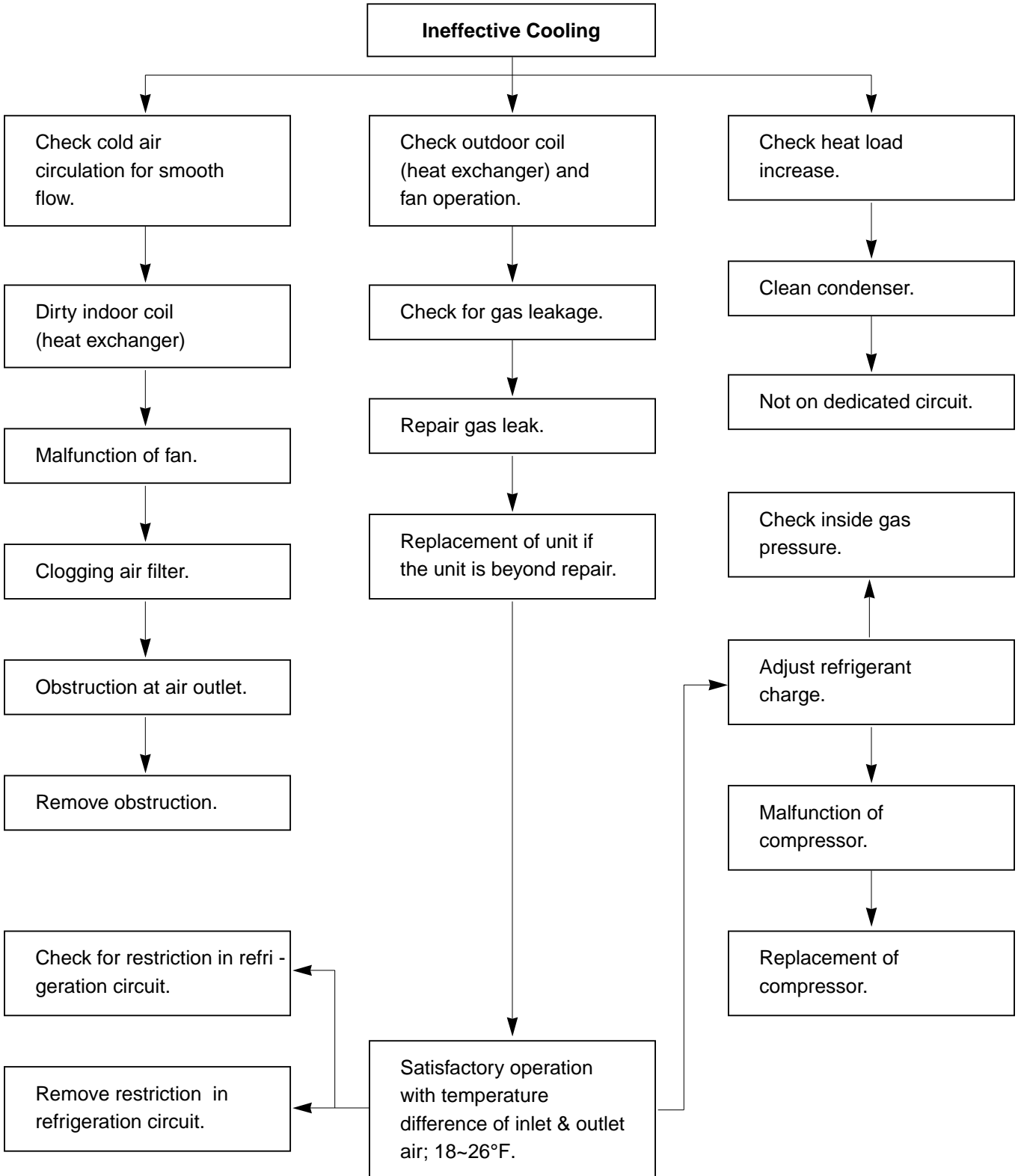

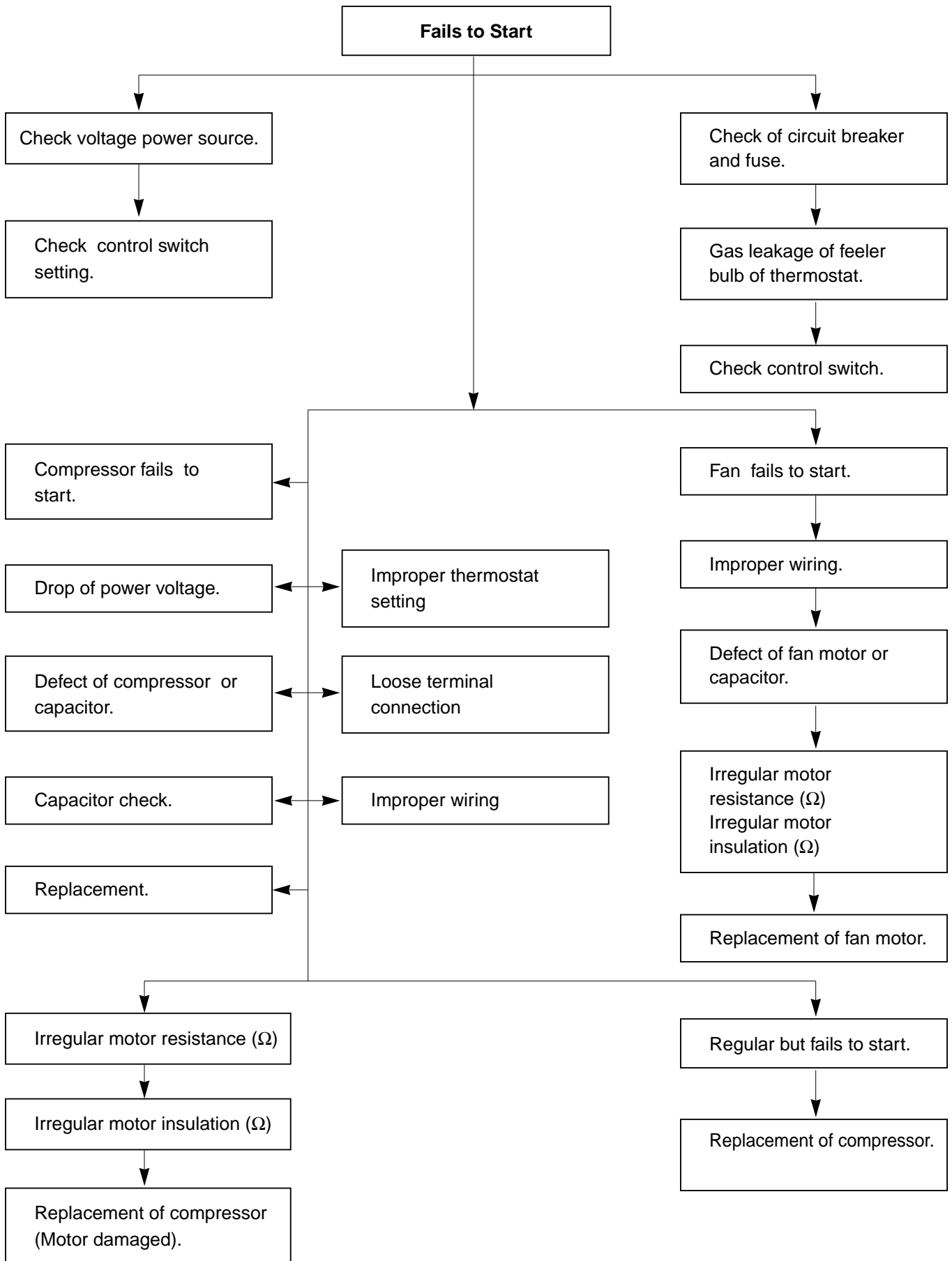

ROOM AIR CONDITIONER VOLTAGE LIMITS

NAME PLATE RATING	MINIMUM	MAXIMUM
115V ± 10%	103.5V	126.5V

COMPLAINT	CAUSE	REMEDY
Fan motor will not run.	No power	Check voltage at outlet. Correct if none.
	Power supply cord	Check voltage to electronic control board. If none, check power supply cord. Replace cord if circuit is open.
	Wire disconnected or connection loose	Connect wire. Refer to wiring diagram for terminal identification. Repair or replace loose terminal.
	Capacitor (Discharge capacitor before testing.)	Test capacitor. Replace if not within ±10% of manufacturer's rating. Replace if shorted, open, or damaged.
	Will not rotate	Fan blade hitting shroud or blower wheel hitting scroll. Re-align assembly. Units using slinger ring condenser fans must have 1/4" inch clearance to the base. If necessary, shim up the bottom of the fan motor with mounting screw(s). Check fan motor bearings; if motor shaft will not rotate, replace the motor.
Fan motor runs.	Revolves on overload	Check voltage. See limits on this page. If not within limits, call an electrician. Test capacitor. Check bearings. Does the fan blade rotate freely? If not, replace fan motor. Pay attention to any change from high speed to low speed. If the speed does not change, replace the motor.

COMPLAINT	CAUSE	REMEDY
Fan motor noise.	Fan blade	If cracked, out of balance, or partially missing, replace it.
	Blower wheel	If cracked, out of balance, or partially missing, replace it.
	Loose set screw	Tighten it.
	Worn bearings	If knocking sounds continue when running replace the motor. If the motor hums or noise appears to be internal while running, replace motor.
Compressor will not run, fan motor runs.	Voltage	Check voltage. See the limits on the preceding page. If not within limits, call an electrician.
	Wiring	Check the wire connections; if loose, repair or replace the terminal. If the wires are disconnected, refer to wiring diagram for identification, and replace the wires. Check the wire connections; If not according to the wiring diagram, correct the connections.
	Thermistor	Check the TEMP control. If not at the lowest number, set TEMP control to this setting.
		Check the continuity of the thermistor. Replace the control board if the circuit is open.
	Capacitor (discharge capacitor before servicing.)	Check the capacitor. Replace if not within $\pm 10\%$ of manufacturer's rating, replace if shorted, open, or damaged.
	Compressor	Check the compressor for open circuit or ground. If open or grounded, replace the compressor.
	Overload	Check the compressor overload if externally mounted. Replace if open. (If the compressor temperature is high, remove the overload, cool, and retest.)
Compressor cycles on overload.	Voltage	Check the voltage. See the limits on the preceding page. If voltage is not within these limits, call an electrician.
	Overload	Check overload, if externally mounted. Replace if open. (If the compressor temperature is high, remove the overload, cool, and retest.)

COMPLAINT	CAUSE	REMEDY
Compressor cycles on overload.	Fan motor	If not running, determine the cause. Replace if required.
	Condenser air flow restriction	Remove the cabinet, inspect the interior surface of the condenser. If restricted, clean carefully with a vacuum cleaner (do not damage fins) or brush. Clean the interior base before re-assembling.
	Condenser fins (damaged)	If the condenser fins are closed over a large area on the coil surface, head pressures will increase, causing the compressor to cycle. Straighten the fins or replace the coil.
	Capacitor	Test the capacitor.
	Wiring	Check the terminals. If loose, repair or replace.
	Refrigeration system	Check the system for a restriction.
Insufficient cooling	Air filter	If restricted, clean or replace.
	Unit undersized	Determine if the unit is properly sized for the area to be cooled.
Excessive noise	Blower or fan	Check the set screw, or clamp. If loose or missing, correct. If the blower or fan is hitting scroll or barrier, rearrange the air handling parts.
	Copper tubing	Remove the cabinet and carefully rearrange the tubing not to contact the cabinet, compressor, shroud, and barrier.

4. CIRCUIT DIAGRAM

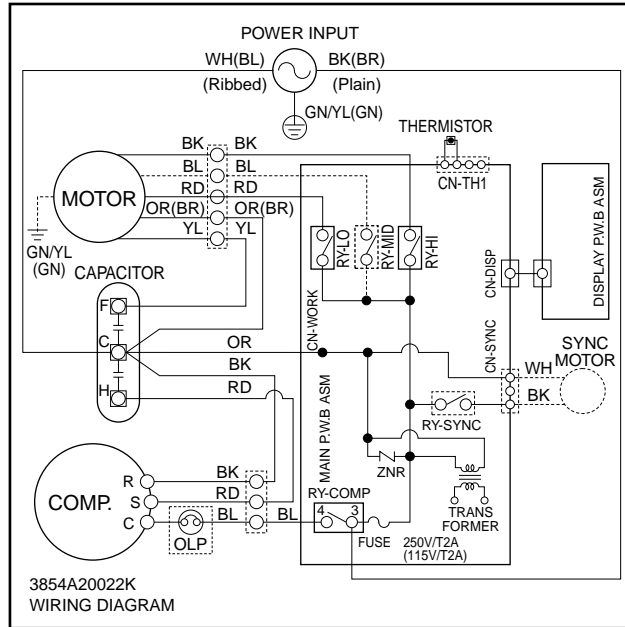

LOCATION NO.	DESCRIPTION	PART NO.	Q'TY PER SET
		CP05C10	
1	POWER CORD ASSY	67300020	1
2	FAN MOTOR	67303026	1
3	COMPRESSOR	67301616	1
4	CAPACITOR	67300718	1
5	OVERLOAD PROTECTOR	67301405	1

5. EXPLODED VIEW

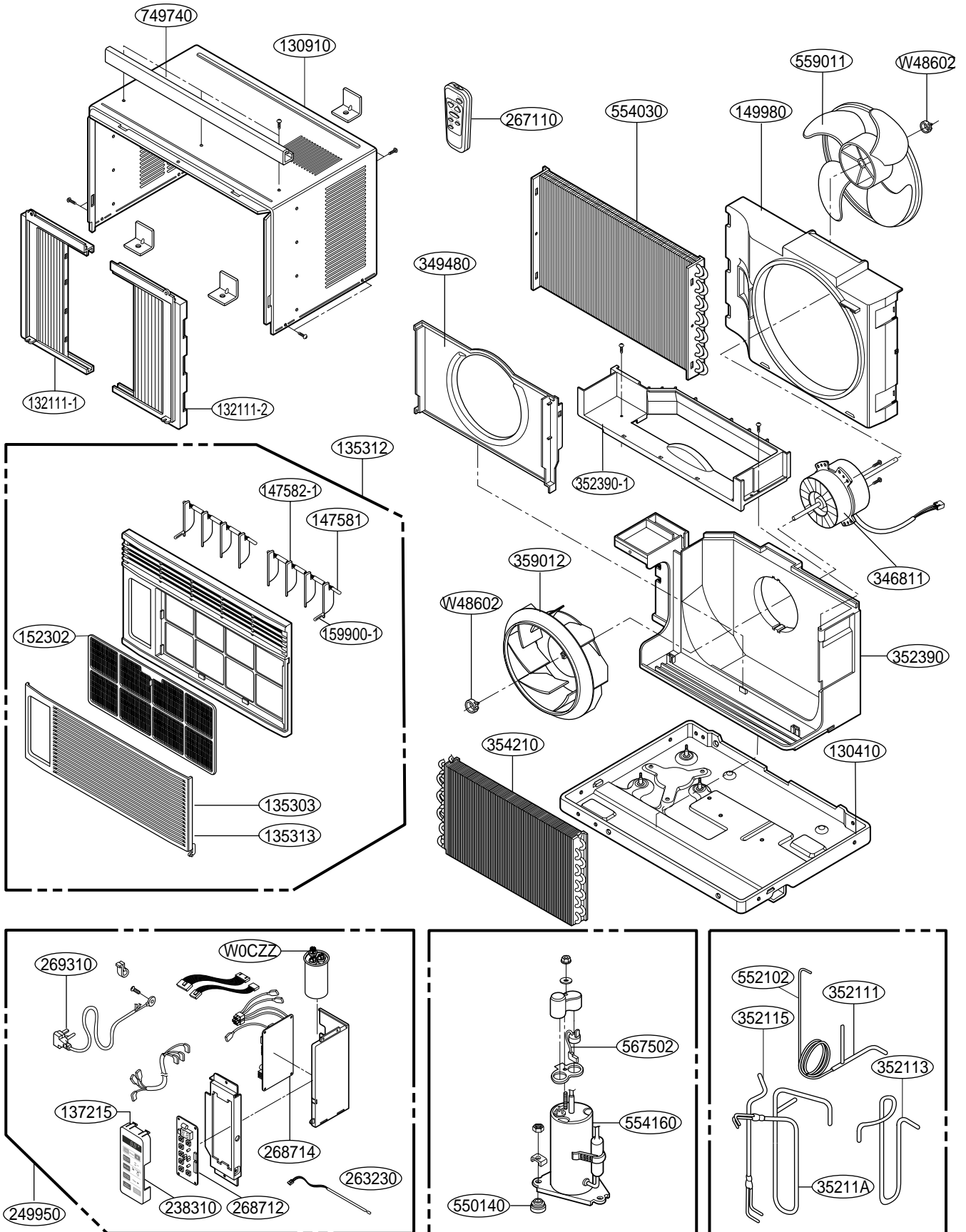

6. SERVICE PARTS LIST

R: Service Parts
N: Non Service Parts

• CP05C10

CP05C10			
LocNo	FRIEDRICH	DESCRIPTION	REMARK
130410	67302921	Base Assy Single	R
130910	67303709	Cabinet Assy Single	R
135312	67306003	Grille Assy Front	R
135313	67304200	Grille Assy Inlet	R
147581	67304600	Link	R
147582-1	67304501	Louver Vertical 2 ea.	R
149980	67303115	Shroud	R
152302	67304300	Filter (Mech)	R
238310	67500115	Escutcheon	R
269310	67300020	Power Cord Assy	R
349480	67307700	Remote Controller	R
352111	67307611	PWB(PCB) Assy Display	R
352115	67307612	PWB(PCB) Assy Main	R
352380	67307806	Thermistor	R
352390	67303026	Motor Assy Single	R
354210	67303410	Orifice	R
35211A	67302222	Tube Assy Suction	R
352113	67302306	Tube Assy Discharge	R
352115	67302021	Tube Assy Evaporator In	R
352390-1	67302727	Air Guide Assy Upper	R
352390	67302734	Air Guide Assy Lower	R
550140	67301900	Isolator Comp	R
352111	67302120	Tube Assy Capillary	R
554160	67301616	Compressor	R
559011	67302613	Fan Assy Axial	R
359012	67302612	Fan Turbo	R
567502	67301405	O.L.P.	R
W0CZZ	67300718	Capacitor	R
W48602	67302500	Clamp Spring	R
132111-1	67306310	Installation Kit w/Curtains L	R
132111-2	67306311	Installation Kit w/Curtains R	R
749740	67304005	Upper Guide Cabinet	R

NOTE) *Please ensure GCSC since these parts may be changed depending upon the buyer's request.
(GCSC WEBSITE <http://biz.LGservice.com>)

MEMO

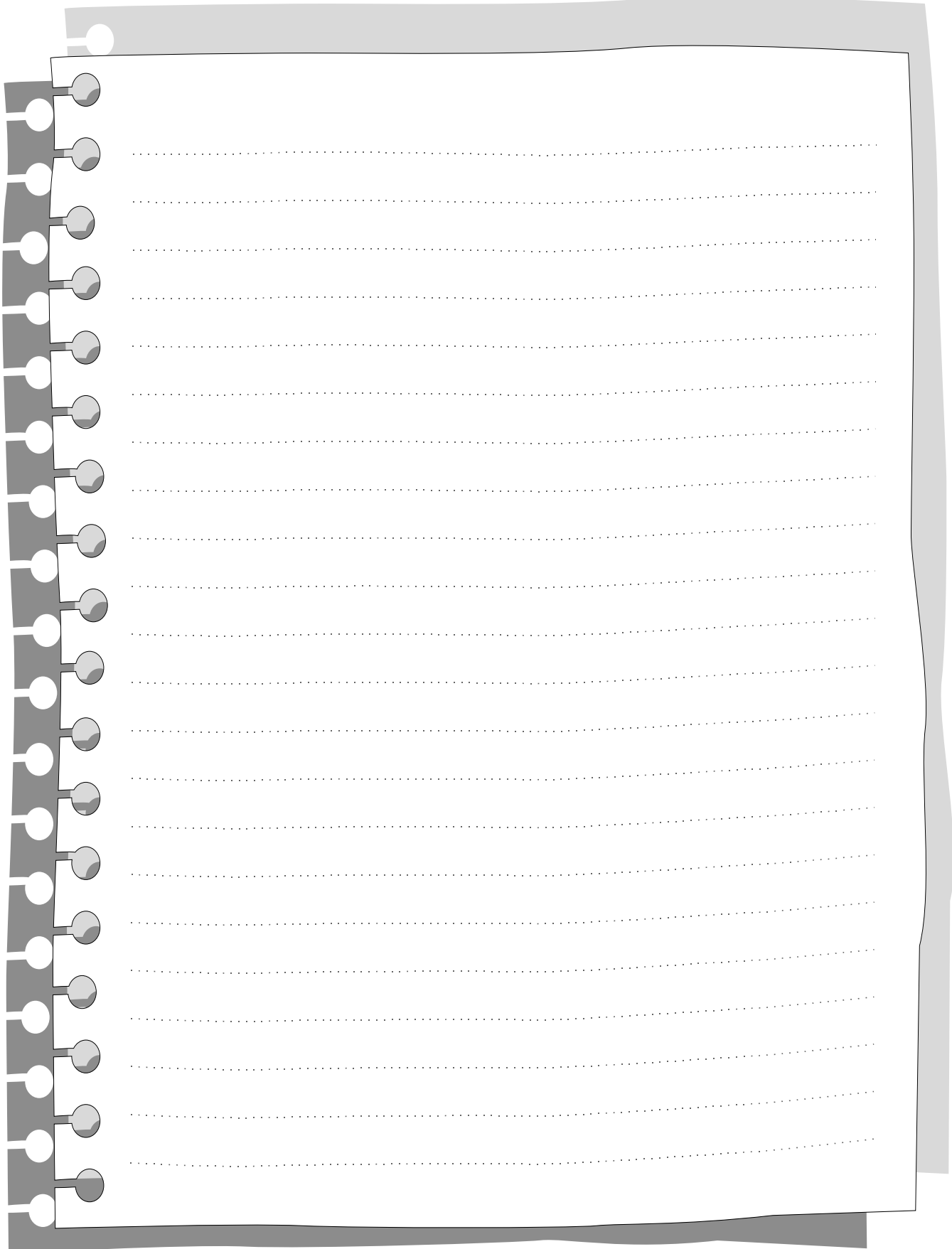

MEMO

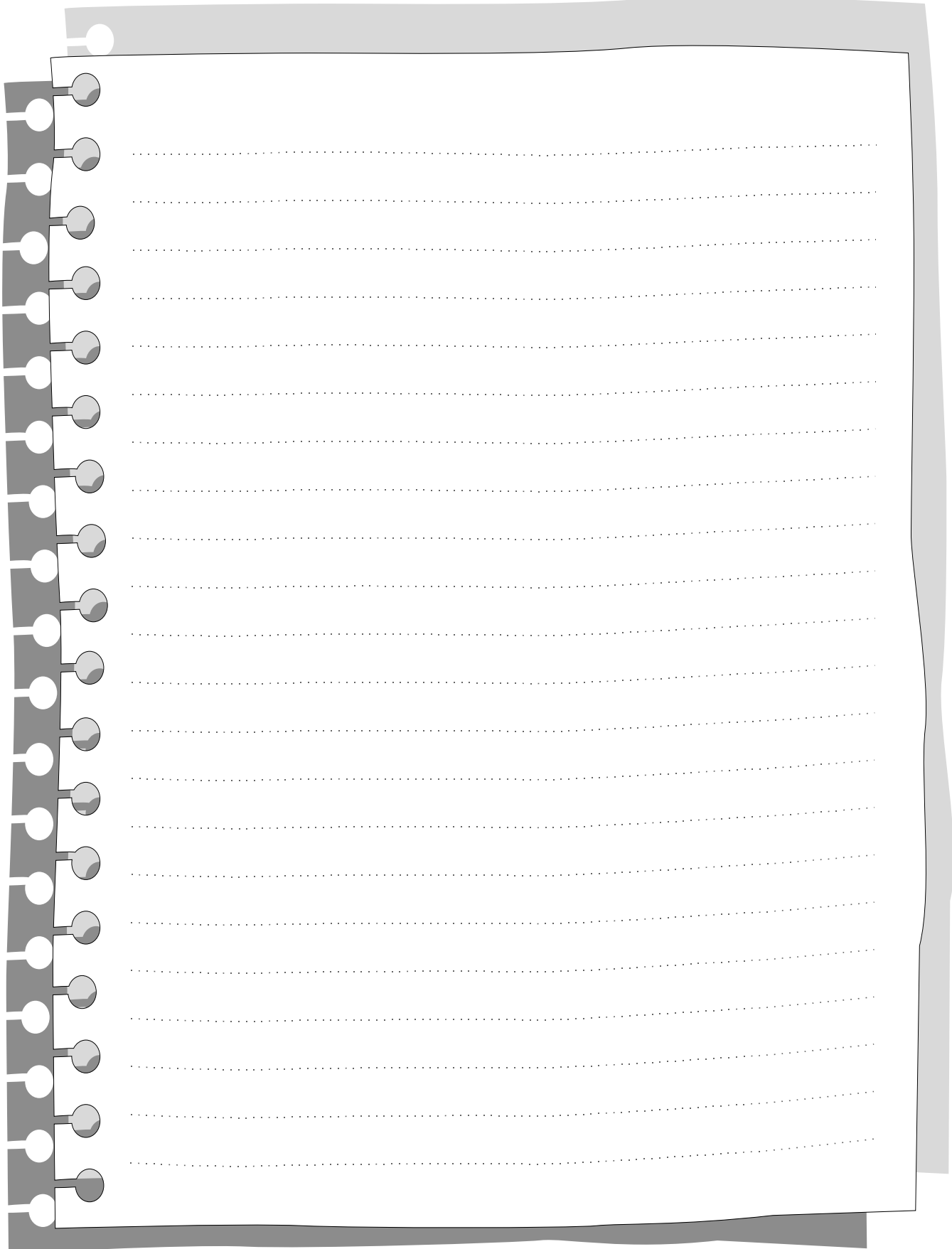

Use Factory Certified Parts...

Friedrich[®]

FRIEDRICH AIR CONDITIONING CO.

Visit our web site at www.friedrich.com

Post Office Box 1540 • 4200 N. Pan Am Expressway • San Antonio, Texas 78295-1540
• (210) 357-4400 • FAX (210) 357-4490

CP05.Svc (05/06)

