

Sunbeam

Mixmaster Series II

600 watt twin-motor benchtop mixer

Instruction/Recipe Booklet

MX7700

Please read these instructions carefully
and retain for future reference.



Contents

Sunbeam's Safety Precautions	1
Features of your Mixmaster Series II	2
Using your Mixmaster Series II	4
Role of the twin-motor	
3-way beating action	6
Mixing Guide	7
Oven Temperature Guide	8
Care and Cleaning	9
Let's Talk Ingredients	10
Cookery Tips for Best Results	12
Helpful Hints for a Successful Dough	13
Helpful Hints for Better Cake Making	15
Recipes	17

تأكد من تفهم احتياطات السلامة المذكورة اعلاه

請務必理解上述的安全預防措施。

Assurez-vous que les précautions ci-dessus relatives à la sécurité sont bien comprises

Versichern Sie sich daß die obenstehenden Sicherheitsmaßnahmen Verstanden werden

Βεβαιώνετε πως οι παραπάνω προφυλάξεις ασφαλείας γίνονται κατανοητές

Pastikan bahwa tindakan-tindakan keselamatan seperti di atas dimengerti anda

Accertatevi che le suddette norme di sicurezza siano comprese a dovere

- 上記の注意事項をよくお読みになり、安全を御確認ください

Уверете се дека погоре споменатите мерки на претпазливост се добро разбрани

Asegúrese de que las precauciones de seguridad precedentes sean bien comprendidas

کاری بکنید کہ احتیاطهای بالا حتماً درک بشوند

ต้องแน่ใจว่า ข้อควรระวังเรื่องความปลอดภัยข้างต้น

เป็นที่เข้าใจกันดี

Yukarda belirtilen güvenlik önlemlerinin anlaşılığınızdan emin olunuz

Xin kiểm chắc rằng những biện pháp làm an toàn kể trên được hiểu rõ

Sunbeam's Safety Precautions

SAFETY PRECAUTIONS FOR YOUR SUNBEAM MIXMASTER SERIES II.

- Never eject beaters or dough hooks when the appliance is in operation.
- Ensure fingers are kept well away from moving beaters and dough hooks.
- Only use the supplied mixing bowl.
- Do not remove the mixing bowl from the base of the Mixmaster whilst mixer is in use.
- When using extremely heavy loads the appliance should not be operated for more than 2 minutes. This does not apply to any

of the recipes in this booklet.

- Should you be using a spatula during mixing, ensure that the spatula is kept well away from moving beaters and dough hooks.
- Never tilt back the head of the Mixmaster whilst the appliance is in operation.
- The mixmaster must be switched off and unplugged before any cleaning.
- Do not restrain the mixer bowl while rotating.
- Turn the Mixmaster off and raise the head before removing the mixing bowl.

Sunbeam are very safety conscious when designing and manufacturing consumer products, but it is essential that the product user also exercise care when using an electrical appliance. Listed below are precautions which are essential for the safe use of an electrical appliance:

- Read carefully and save all the instructions provided with an appliance.
- Always turn the power off at the power outlet before you insert or remove a plug. Remove by grasping the plug - do not pull on the cord.
- Turn the power off and remove the plug when the appliance is not in use and before cleaning.
- Do not use your appliance with an extension cord unless this cord has been checked and tested by a qualified technician or service person.
- Always use your appliance from a power outlet of the voltage (A.C. only) marked on the appliance.
- Close supervision is necessary when your appliance is being used near children or infirm persons.
- Never leave an appliance unattended while in use.
- Young children should be supervised to ensure that they do not play with the appliance.
- Do not use an appliance for any purpose other than its intended use.
- Do not place an appliance on or near a hot gas flame, electric element or on a heated oven. Do not place on top of any other appliance.
- Do not let the power cord of an appliance hang over the edge of a table or bench top or touch any hot surface.
- For safety reasons and to avoid maintenance by unskilled persons, some appliances are 'sealed' using tamperproof screws. Such appliances should always be returned to the nearest Sunbeam Appointed Service Centre for adjustment or repair if required.
- Do not operate any electrical appliance with a damaged cord or after the appliance has been dropped or damaged in any manner. If damage is suspected, return the appliance to the nearest Sunbeam Appointed Service Centre for examination, repair or adjustment.
- For additional protection, Sunbeam recommend the use of a residual current device (RCD) with a tripping current not exceeding 30mA in the electrical circuit supplying power to your appliances.
- Do not immerse the appliance in water or any other liquid unless recommended.

If you have any concerns regarding the performance and use of your appliance, please visit www.sunbeam.com.au or contact the Sunbeam Consumer Service Line. Ensure the above safety precautions are understood.

Features of your Sunbeam Mixmaster Series II

Attachment eject button

The eject button effortlessly releases the beaters or dough hooks for easy cleaning.

Twin-motor 3-way beating action

Sunbeam's famous 3-way beating action with patent pending twin-motor technology provides a powerful mixing action and more thorough result. The first motor drives the individual beaters in opposite directions while the second drives the bowl.

Off-centre mixing head and beaters

The head of the Mixmaster and beaters are positioned off-centre to the bowl to make it easier to add ingredients during mixing.

4 litre stainless steel mixing bowl

4 litre stainless steel mixing bowl locks onto the base of the mixer and is designed specifically for mixing regular to large quantities of ingredients.

Spatula

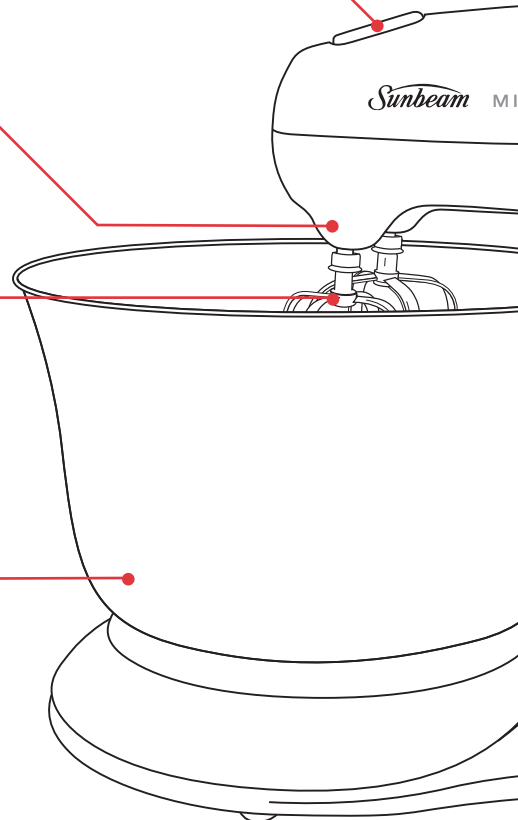
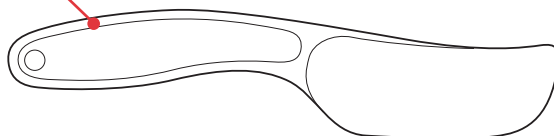

XMASTER
SERIES II

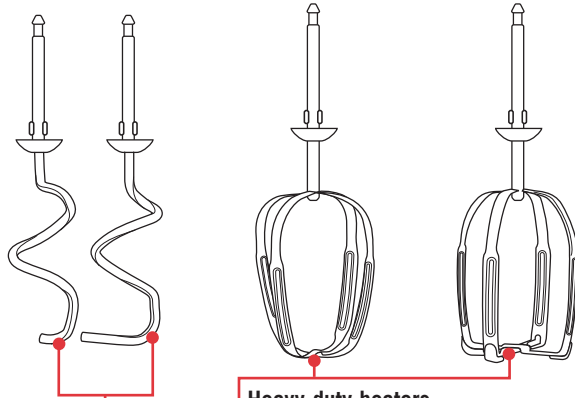

Heavy-duty beaters

Designed for optimum mixing and aeration, ideal for creaming butter and sugar, plus mixing heavy cake mixes.

Dough hooks

Heavy duty dough hooks take the hard work out of kneading dough and other heavy mixtures.

12 speed control dial

12 speed electronic torque control motor maintains the selected speed regardless of the mixing load.

Tilt back and locking head button

The head of the Mixmaster tilts back and locks securely into position to allow for easy removal of mixing bowl and attachments.

Bowl speed control dial

The bowl speed control has the options of high and low allowing you to select the optimal bowl speed for different mixing tasks.

Non-slip rubber feet

Keep the mixer secure on the bench top during use.

Using your Sunbeam Mixmaster Series II

Before using your Mixmaster Series II

Before assembling your Sunbeam Mixmaster Series II, be sure the power cord is unplugged from the power outlet and the speed control dial is in the 'O' position.

1. Press the 'tilt' button, located on the neck of the Mixmaster and swing the mixer head up, see Figure 1. The mixer head will lock into this tilt position.

Figure 1

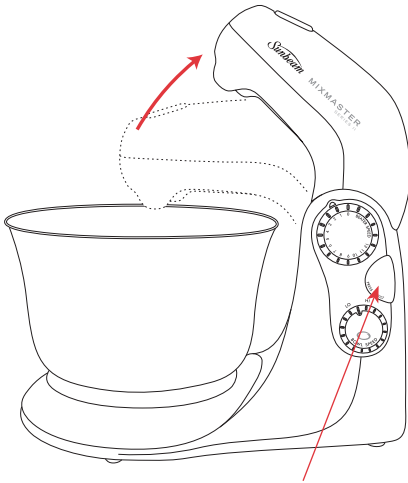

Press 'tilt' button and tilt the mixer head backward.

2. Select the desired attachments depending on the mixing task to be performed;
 - Beaters for creaming butter and sugar, mixing cake mixes and whisking cream and egg whites.
 - Dough hooks for kneading dough and other heavy mixtures.

Inserting attachments

- 3a. Take the two beaters, place the oval shaped beater (A) into the left socket, (outer position). Place the other beater, with the plastic nodules on the base (B) into the right socket, (inner position), see Figure 2.

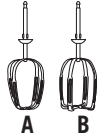
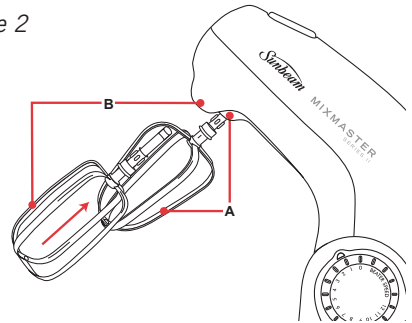

Figure 2



- 3b. Take the two dough hooks, place the dough hook with the shorter hook at the bottom (A) into the left socket, (outer position). Likewise, place the dough hook with the longer hook at the bottom (B) into the right socket, (inner position), see Figure 3.



Figure 3

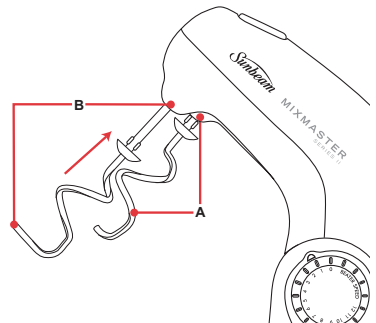

Important: Please review Figure 4. The illustration on the left is how the dough hooks should look when correctly inserted. However should the dough hooks once

Using your Sunbeam Mixmaster Series II (continued)

inserted appear to be touching, as they do in the illustration on the right, then they have been inserted incorrectly.

Figure 4

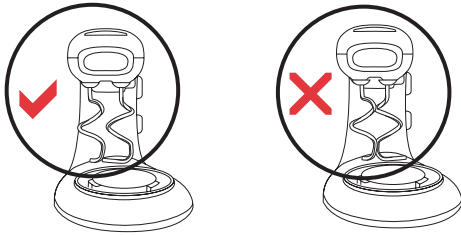

Note: Be sure both beaters or dough hooks click firmly in place, you may need to twist the attachments slightly to engage them in position prior to pushing them into place.

Attachments can only be locked in place if they are in the correct socket. If only one of the attachments will lock in place, the attachments are in the wrong sockets.

4. Place the mixing bowl onto the metal base plate so that it is sitting evenly. Lock the bowl into place by turning it clockwise, see Figure 5.

Figure 5

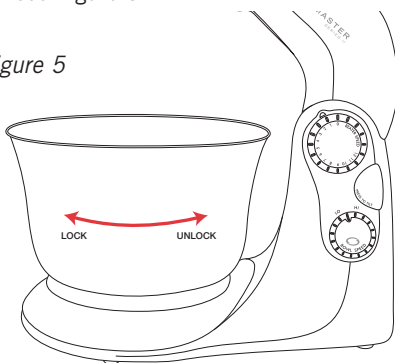

5. Press 'tilt' button to lower the head with the selected attachments (either, beaters or dough hooks) in place, into the mixing bowl. See Figure 6.

Figure 6

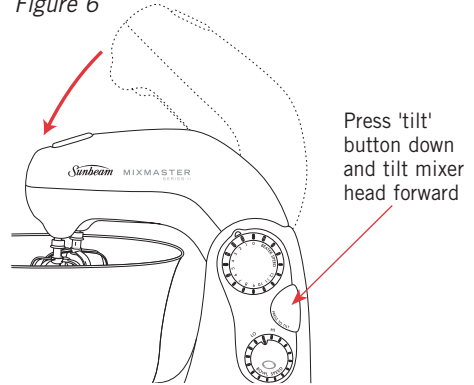

Using your Mixmaster Series II

1. With the speed control dial in the '0' position, plug the power cord into a 230-240 volt power outlet.

Note: The power indicator light on the speed control dial will now be illuminated.

2. Use the speed control dial to turn the Mixmaster ON and OFF and to control the mixing speeds.

Clearly marked instructions for correct mixing speeds for each type of mixture are shown in the 'Mixing Guide' on page 7.

Tip: Start mixing at slow speeds and increase speed gradually to prevent ingredients splashing out of the mixing bowl. When adding dry ingredients, particularly flour, lower the speed temporarily until ingredients are combined.

Tip: When kneading yeast doughs, use speed 1 to achieve best results. For specific instructions for the use of dough hooks see 'Helpful Hints for a Successful Dough' on page 13.

Selecting the mixing bowl speed

1. The mixing bowl automatically turns on when the speed control dial is turned on. For majority of mixing tasks the

Using your Sunbeam Mixmaster Series II (continued)

bowl speed should be set on the 'LO' speed setting. For light mixes requiring maximum mixing performance such as cakes and meringue, the 'HI' bowl speed is recommended as this passes the mixture through the beaters more often for faster results. For large volumes the bowl speed should be reduced to "LO", particularly in thick mixtures.

2. When mixing is complete, turn the speed control dial to the 'O' position and unplug the cord from the power outlet.

Note: The indicator light will stay on until power is disconnected from the mixer.

3. Hold down the 'tilt' button and ease the Mixmaster head back until the mixer head is locked into the tilt back position, see Figure 1.
4. To remove the particular attachments (either beaters or dough hooks), place

fingers loosely around the attachments and hold down the 'beater eject' button see Figure 7.

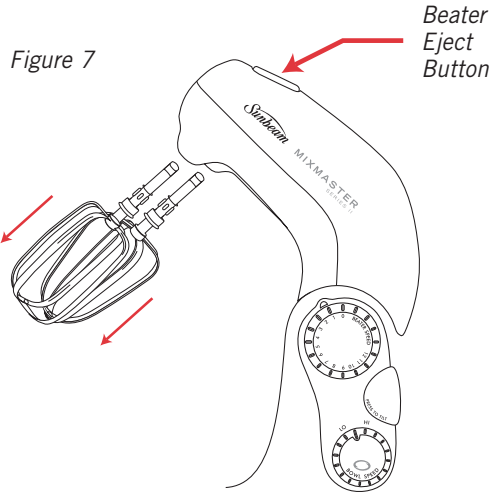

Role of the Twin-motor 3-way beating action

One motor is located in the head of the Mixmaster. This drives the individual beaters, turning each in opposite directions.

The second motor is located in the neck of the Mixmaster and drives the turntable, in turn rotating the bowl. High or low bowl speed can be selected by simply turning the control dial positioned on the neck of the Mixmaster Series II.

These actions combine to ensure a more powerful and thorough mixing result.

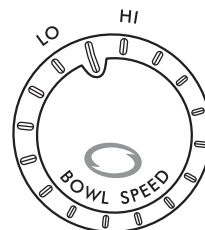

Mixing Guide

Please keep in mind that the various mixing tasks and related speeds, listed in the table below, may vary slightly from recipe to recipe.

Please refer to it regularly as you develop your understanding of how different ingredients interact when mixing.

SPEED SETTING RANGE	MIXING TASK
LOW 1 2 3	FOLDING & BLENDING Scones/Pastry Biscuit dough Tea Cakes
MEDIUM 4 5 6	LIGHT MIXING Sauces & Puddings Custard/Icing Packet Mixes
HIGH 7 8 9	CREAMING & BEATING Butter & Sugar Cream Cheese Heavy Batters
VERY HIGH 10 11 12	WHIPPING & AERATING Cream Egg Whites & Meringues Marshmallow

NOTES: For most recipes, it is better to begin your mixing on a slower speed until the ingredients begin combining, then move to the appropriate speed range for the particular task.

Generally there is no one set speed for an entire recipe. You will need to change the speed of the Mixmaster depending on what stage of the recipe you are working on. This is communicated in the recipe section.

When mixing larger quantities you may need to increase the Mixmaster speed due to the amount of mixing required and the larger load on the machine.

When building up a recipe that requires the addition of dry ingredients, such as flour, slow the speed down whilst these ingredients are being added to avoid a snow storm effect. Once the extra ingredients begin combining then slowly increase to the appropriate speed for the particular mixing task.

Oven Temperature Guide

For your information, the following temperature settings are included as a guide. These settings may need to be adjusted to suit the individual range.

Description of Oven Temperatures	Thermostat Settings			
	Electric		Gas	
	°F	°C	°F	°C
Cool	200	110	200	100
Very Slow	250	120	250	120
Slow	300	150	300	150
Moderately Slow	350	170	325	160
Moderate	400	200	350	180
Moderately Hot	425	220	375	190
Hot	450	230	400	200
Very Hot	475	250	450	230

Note: If using fan forced ovens be sure to turn the temperature down by 20-30°C. Also check recipes at the back of this book.

Care and Cleaning

Before cleaning your Sunbeam Mixmaster Series II, ensure the power is turned off at the power outlet, then remove the plug.

Wipe over the outside area of the Mixmaster and base with a dampened cloth and polish with a soft dry cloth.

Wipe any excess food particles from the power cord.

Wash the mixing bowl, beaters and dough hooks in warm soapy water and wipe dry. Give special attention to the nylon button area on the beater - use a brush if necessary to remove sticky food particles. The stainless steel mixing bowl, beaters and dough hooks may also be placed and washed in the dishwasher.

Maintenance Service

Your Sunbeam Mixmaster Series II should be regularly checked. After approximately four years of domestic use, the grease in the gear compartment should be examined (commercial use after two years). We suggest at that time you send the Mixmaster to your nearest Sunbeam Appliance Service Centre to ensure efficient, correct servicing.

Note: The Sunbeam Mixmaster Series II and the base have been factory oiled and no additional home oiling is necessary.

Storage

Keep your Sunbeam Mixmaster Series II in a convenient position on your kitchen bench ready for use at all times. Place the beaters and dough hooks into the bowl (storage of beaters and dough hooks in a drawer with other kitchen equipment may cause damage).

Note: Never wind the power cord around the motor after use as the warmth of the motor may cause damage to the power cord.

Lets Talk Ingredients

Listed below is a guide regarding some of the ingredients used in the recipes in this book.

Butter

Butter is made from approximately 80% milk fat (cream) and is churned over a period of time to produce a solid (butter). Butter is used to stabilize, texturize and add flavour. Butter may be salted or unsalted, it is best to use unsalted butter for cake baking. Clarified butter has the milk solids and salt removed, which is ideal for pastry making as it can be heated to higher temperatures than regular butter.

Note: Margarine can be used as a substitute for butter. It is made from vegetable oils, therefore it may alter the end result. There are various types of margarines, some of these are butter-margarine blends and fat reduced.

Yeast

A raising agent used in doughs. Yeast is a microscopic living organism that grows rapidly in suitable warm, moist conditions. The yeast plant feeds on sugar and expels carbon dioxide which expands the gluten framework. When foaming yeast do not allow the water temperature to exceed 40°C, as this will kill the yeast. A 26°C - 30°C, draft free area is most suitable for the growth of yeast during the rising process. Both Dry Yeast and fresh Compressed Yeast may be used in the recipes included in this book. (NB. 7g of dry yeast is equivalent to 20g of compressed yeast).

Substitutes

If you find it necessary to substitute ingredients in a recipe, check the following alternatives:

1 cup self raising flour = 1 cup plain flour and 2 teaspoons baking powder.

1 cup plain flour and 1 teaspoon baking powder = ½ cup each of plain and self raising flour.

Sultanas = equal measure of any other dried fruit.

Golden Syrup = equal measure of treacle or molasses.

1 cup buttermilk = 1 cup fresh milk and 2 teaspoons vinegar or lemon juice.

Lets Talk Ingredients (continued)

Measuring Ingredients

Careful and correct measurement of all ingredients is essential for recipe success. Australian Standard Metric cup and spoon measures are used in all recipes in the book. All cup and spoon measurements should be level.

- One metric tablespoon is equal to 20mls.
- One metric teaspoon is equal to 5mls.
- One liquid cup measurement is equal to 250mls.

The following are some hints on measuring ingredients.

Wet Ingredients

Place the measuring jug on a level surface and check the measurement at eye level.

Dry ingredients

Use a standard metric measuring cup and spoon to measure out dry ingredients. After filling, level off cup or spoon with a knife. You may like to tap the cup or spoon lightly on the kitchen benchtop before levelling. If your dry ingredients has any lumps, be sure to remove them or break them up, sifting ingredients prior to mixing will help.

Raising Agents

Care is essential for best results. Check for and crush any lumps, particularly in bicarbonate of soda, before measuring.

Cheese and Breadcrumbs

Pack grated cheese and soft breadcrumbs into the cup pressing lightly to obtain best results.

Fats and Oils

The simplest method to measure butters, margarines and shorting is to cut or spoon the required amount from the block or container and then weigh it using metric scales.

Cookery Tips for Best Results

1. Before starting, read the recipe completely.
2. Refrigerated ingredients, ie butter and eggs should be at room temperature before mixing begins. Set these ingredients out ahead of time.
3. Before starting your recipe preheat oven to baking temperature recommended in the recipe.
4. Assemble all ingredients and utensils near the mixer.
5. To eliminate the possibility of shells or deteriorated/off eggs in your recipe, break eggs into a separate container first, then add to the mixture.
6. When mixing egg whites, be sure the bowls and beaters are thoroughly cleaned and dried. As even the smallest amount of oil on beaters or bowl may cause the egg whites not to aerate.
7. Always start mixing at slow speeds. Gradually increase to the recommended speed as stated in the recipe.
8. Do not over beat. Be careful that you only mix/blend mixtures until the recommended time specified in your recipe. Fold in dry ingredients only until just combined. Always use the low speed. At any stage of mixing, over beating can cause toughness, close texture, lack of rising or excessive shrinkage. Climatic conditions, seasonal temperature changes, temperature of ingredients and their texture variation from area to area all play a part in the required mixing time and the results achieved.
9. All recipes have been kitchen tested, but should you find it necessary to vary the ingredients or the size of the tin etc. allow for a variation in cooking time. Always test for doneness in baked foods before removing from the oven or the cooking appliance.
10. During mixing, ingredients may splash to the sides of the bowl. To scrape the bowl, turn the speed control dial to the '0' position and using a spatula, scrape the bowl. NEVER USE A KNIFE, METAL SPOON OR FORK, as this may cause damage to the beaters and bowl. A light scraping after the addition of each ingredient assists in achieving efficient mixing.

Helpful Hints for a Successful Dough

Step 1: Preparing the yeast

For the dry yeast to be activated it needs to ferment. To do this place warm milk, sugar and the tepid water into a bowl, add dry yeast and mix. Stand in a warm place until mixture starts foaming ie bubbles. This process will take approximately 10 minutes. Be sure not to overheat the milk. As hot temperatures will kill and deactivate the yeast.

Step 2: Preparing the dough

Note: Ensure dough hooks are in place (refer to page 4).

1. Place the dry ingredients into the Mixmaster bowl and position onto the turntable. Turn the speed control switch to speed 1. Begin to gradually add the liquid ingredients to the bowl.

Note: You may find it useful to use a spatula to scrape the dry ingredients from the sides of the bowl.

Safety Tip: Do not attempt to feed the dough into the dough hooks with your hands, spatula or any other utensil while the mixer is plugged into a power outlet or in operation.

2. As the ingredients start to form a ball, scrape down the sides of the bowl if necessary with a plastic spatula and remove your dough.

Safety Tip: Do not use the mixer near the edge of a bench or table top where it may fall off.

3. Depending on what recipe you are making, generally you will need to add manual kneading to your dough. Place dough onto a well floured work bench or surface and knead until dough is smooth and elastic. This should take approximately 3-5 minutes.
4. After kneading place dough into a large well greased mixing bowl. Place the bowl in a warm, draft-free area and cover with a light cloth until the dough doubles in size.
5. Plunge fist into the centre of the risen dough to punch out excess air. Fold outer edges into the centre and turn dough out onto a lightly floured board for shaping. Place dough into tins for baking, or cut and shape dough for making buns, rolls, etc.
6. Final rising of dough. Cover the dough with a light cloth and place in a warm, draft-free area until doubled in size again. Glaze and bake.

Helpful Hints for a Successful Dough (continued)

Step 3: The finishing touches

To add interest to breads

- Sprinkle loaves or buns with sesame, poppy, or caraway seeds before baking.
- Top loaves with shredded cheese during the last few minutes of baking.
- Drizzle sweet tea rings or buns with an icing sugar when cooled.

Glazes

- May be brushed over the dough at any time before, during or after baking.

Before Baking

- For a shiny crust, brush with cream or evaporated milk.
- For a glossy crust, brush with beaten egg white.

After Baking

- For a matt finish, brush with melted butter or margarine.

Doughy Tips.

- Q.** I followed the recipe, however I'm finding that my mixture is dry and crumbly. Do I need to add more water?
- A.** Your mixture may be dry and crumbly for several reasons. One common problem is that flour tends to absorb or want more moisture/liquid, especially on a warm or humid day. We suggest you add more water, a drop at a time, until you reach a smooth ball/dough.
- Q.** I added too much water and my dough is very sticky, what can I do?
- A.** If the dough is smooth without lumps, then remove the dough from the bowl and turn it out onto a well floured benchtop. Knead the dough until you get a smooth and well formed dough, that is soft to touch and bounces back when pressed with the tip of your finger.
- Q.** My yeast did not bubble, why?
- A.** The yeast may not be active anymore. Check the use by date and when not using yeast be sure to store in the fridge.
- Q.** My dough did not rise, why?
- A.** Firstly check the freshness of the yeast. Otherwise it may need to be placed in a warmer position. Placing the dough in a bowl and covering with plastic wrap then placing in a sink with some warm water may help.

Helpful Hints for Better Cake Making

- Always have ingredients at room temperature. Warm the bowl to be used in really cold weather.
- Add flavouring and essences to the shortening for a better flavour.
- When creaming butter and sugar beat until light and creamy.
- Add whole eggs one at a time and beat until egg is absorbed. Eggs should not be cold as they can curdle mixtures.
- In our recipes we will use self-raising flour wherever possible. If plain flour is called for, it must be used to keep the balance of ingredients correct.
- Divide the flour and the liquid into two portions and add alternately with the liquid on speed 1 - don't over beat.
- If you don't have a tin the same size as the recipe suggests, here are some tins that are of similar capacity:
Use 2 x 20cm sandwich tins or a 1 x 28 x 18cm lamington tin or a 1 x 20 x 7cm deep round cake tin or 1 x standard loaf tin or a 1 x 20cm ring tin.
- Care must be taken when using a cake tin instead of a sandwich tin to lower the suggested temperature by approximately 25°C and lengthen the cooking time.
- Care should also be taken when substituting a cake tin for a ring tin, baba tin or any tin with a funnel as some cake mixtures that have a very high fat content may need the heat supplied by way of the funnel.

- Cooking times and temperatures are meant only as a guide. Light mixtures should spring back when lightly touched and heavier cake mixes should be tested using a wooden skewer. Fruit cakes should be tested using a small sharp knife. This should be done towards the end of the suggested cooking time.

Reasons for Poor Results

Sponge Cakes Shrink

Unbalanced ingredients, overbeating of egg whites, sudden changes of temperature or draught when taking from the oven.

Cakes Do Not Rise

Mostly due to gross overbeating, but can also be caused by too hot an oven during the first part of cooking.

Cakes Sink in the Centre

Too much fat, raising agent, liquid or sugar; too little flour; under cooking or slow cooking.

Cakes Run Over at Edges

Too much batter for size of pan, too cool an oven, too much sugar, too much raising agent.

Hard Outer Crust

Too much flour, too little sugar, over mixing, too hot an oven.

Moist, Sticky Outside

Too much sugar, over beating, under baking.

Coarse Crumbly Texture

Overbeating, low baking temperature.

Helpful Hints for Better Cake Making (continued)

Heavy, Close Texture

Too much fat or sugar, over mixing, under baking, or too hot an oven.

Fruit Sinks

Mixture too soft, damp fruit, too little flour, ingredients not correctly balanced, over beating.

Some Hints on Sponge Making

- There are basically two methods of sponge making. The whole egg method is the simpler, but better volume can be achieved if the egg whites are separated from the yolks.
- If you elect to separate the eggs, whip the whites until they hold peaks and gradually add the sugar a little at a time, beating well between each addition. Start with tablespoons of sugar and, as the mixture stiffens, add it more quickly. This process should take about 3-5 minutes. Only fold in the egg yolks until they disappear, say ½ minute.

These General Tips apply to either method:

- Eggs should be at room temperature.
- Caster sugar will give a better result as it dissolves more quickly.
- Bowl and beaters should be clean, dry and free from any fat.
- The fold speed of the Mixmaster will supply the gentle but thorough action necessary to fold in flour. Care should be taken to mix only until the flour has just been folded through the egg mixture. Always commence mixing on speed 1.

- Triple sift the flours. This will incorporate as much air as possible into the flours.
- Don't rush the folding in, use either a large metal spoon or even your clean hand.

Swiss Rolls

- The sponge mixture must be evenly distributed. A better result will be achieved if the mixture is poured along the tin and the tin tilted to allow the mixture to run to the corners, rather than spreading the mixture.
- While the roll is baking, sprinkle a little crystal sugar onto the sheet of greaseproof paper larger than the Swiss roll tin. Soften the jam to make it easy to spread. Immediately after the roll comes from the oven, turn in onto the prepared paper and quickly spread the jam right out to the corners. Make the first roll a tight tuck and use the greaseproof paper to help you handle the hot sponge.
- It is essential the sponge is rolled quickly and that sponge is not over-cooked or the roll will crack.

Recipes

Tips

- Goats milk and skim milks can be used in these recipes.
- Margarine's and low fat butter's can also be used in these recipes.

Basic White Loaf

1 sachet 7g dry yeast
1 tablespoon sugar
1 cup lukewarm water
¾ cup lukewarm milk
60g butter, melted
4 cups plain flour
1 teaspoon salt

1. Combine the first five ingredients in a small bowl and allow to stand in a warm place until mixture begins to froth. About 10 minutes.
2. Insert dough hooks into the mixer head (refer to page 4). Place sifted dry ingredients into the Mixmaster bowl.
3. With the bowl speed set on Low start mixing on Low speed (1-2), gradually add yeast mixture. Note that it will be necessary to scrape sides of bowl with a spatula. Knead on Medium speed (4) for 3-4 minutes, keep bowl speed on Low.
4. Continue the kneading process at Medium speed (4) until all ingredients are incorporated and dough forms a smooth ball. Mixture will be wet and sticky. Remove dough from bowl using a spatula.
5. Place dough in a greased bowl, turning once to grease top of dough. Cover, and let rise in a warm place until doubled in size (40-50 minutes).
6. Punch down, fold sides to centre and turn the dough over. Remove the dough from the bowl and place onto a well floured surface. Lightly knead dough with palm of your hands until smooth and elastic. Cut dough in half and shape into two loaf pans. Cover loosely with plastic wrap and

allow to rise in a warm place until doubled in size. About 30-40 minutes. Preheat oven to 200°C.

7. Bake for approximately 30 minutes. Baked loaves sound hollow when tapped.

Variations to this recipe:

Breadsticks

1. Follow steps 1 - 5 from 'Basic White Loaf' recipe.
2. Punch down, fold sides to centre and turn the dough over. Knead on a lightly floured surface. Cut the dough into 8 portions and in each portion cut 1cm length slices.
3. Cut each slice into 1cm strips and roll into thin long stick like shapes.
4. Place onto a baking tray lined with baking paper, brush with milk and sprinkle with sea salt, and or poppy seeds and sesame seeds or cajun seasoning.
5. Bake on 200°C for 15 minutes, or until dry and crisp and golden brown.

Bread rolls

1. Follow steps 1 - 5 from 'Basic White Loaf' recipe.
2. Punch down, fold sides to centre and turn the dough over. Knead lightly on a well floured surface. Cut the dough into 12 portions and roll each portion across the bench, until an even soft ball is achieved.
3. Place each portion of dough onto a baking tray lined with baking paper. Cover in plastic wrap, allow to double in size (about 20-40 minutes) brush with eggwash and sprinkle with a mixture of poppy and sesame seeds.

Note: Eggwash is a mixture of egg yolk and tepid water used to glaze the top of uncooked bakery goods to give a shiny glaze.

4. Bake on 200°C for 15-20 minutes.

Recipes continued

Sesame Rolls

1. Follow steps 1 - 5 from 'Basic White Loaf' recipe.
2. Preheat oven to 220°C. Line a baking tray with baking paper.
3. Punch down, fold sides to centre and turn the dough over. Knead on a lightly floured surface. Divide the dough into 24 equal portions and shape into round, smooth balls.
4. Place close together onto the prepared tray and brush with melted butter and sprinkle with sesame seeds.
5. Cover with plastic wrap and allow to rise in a warm place for approximately 10 minutes.
6. Bake for approximately 20 minutes. Baked rolls sound hollow when tapped with the knuckles.

Variations to this recipe:

Flat rolls can be made using this recipe. After dividing the dough into equal portions and shaping into rounds, flatten each round with a rolling pin to approximately 1.5cm thick. Place close together on prepared trays, brush with melted butter and sprinkle with sesame seeds. Cover with plastic wrap and allow to rise in a warm place for approximately 10 minutes. Bake for approximately 20 minutes.

Sultana Loaf

Makes 2 loaves

- 1 sachet (7g) dry yeast
 - 2 tablespoons sugar
 - 60g butter or margarine, melted
 - 1¼ cup lukewarm milk
 - ¾ cup water
 - 4 cups plain flour or bakers flour
 - 2 tablespoons sugar, extra
 - 2 tablespoons powdered milk
 - 1 teaspoon salt
 - 1 cup sultanas
1. Combine the first five ingredients in a small bowl and allow to stand in a warm place until mixture begins to froth. About 10 minutes.
 2. Insert dough hooks into the mixer head (refer to page 4). Place sifted dry ingredients, including sultanas into the Mixmaster bowl.
 3. With the bowl speed set on Low start mixing on Low speed (1-2), gradually add yeast mixture. Note it will be necessary to scrape sides of bowl with a spatula. Knead on Medium speed (4) for approximately 4-5 minutes, keep bowl speed on Low.
 4. Continue the kneading process at Medium speed (4) until all ingredients are incorporated and dough forms a ball. Note mixture should be wet and sticky. Remove dough from bowl using a spatula.
 5. Place dough in a greased bowl, turning once to grease top. Cover with plastic wrap, and let rise in a warm place until doubled in size (40-50 minutes).
 6. Punch down, fold sides to centre and turn the dough over. Turn dough out onto a well floured surface and knead lightly for 1-2 minutes until smooth. Cut and shape into loaf pans. Cover with plastic wrap and allow to rise in a warm place until doubled

Recipes continued

in size, approximately 20 minutes. Preheat oven to 200°C.

7. Bake for approximately 30 minutes. Baked loaves sound hollow when tapped with the knuckles. Makes 2 loaves.

Tip: If dough is too wet, while mixer is kneading slowly sprinkle about a tablespoon at a time of flour until mixture is smooth and moist but not wet. Dough should be slightly sticky, soft and elastic.

Variations to this recipe:

The sweet yeast dough can be used to make various sweet bakery goods such as the plaited sweet loaf, Chelsa bun or hot cross buns.

Plaited sweet loaf

1. Follow steps 1 - 5, from 'Sultana Loaf' recipe.
2. Punch down, fold sides to centre and turn the dough over. Knead on a lightly floured surface with well floured hands, until smooth, soft and elastic. Cut dough in half and roll out one half on a floured surface and shape into a 60cm x 30cm rectangle, about 2cm thick.
3. Cut into 3 equal lengths, bring each together at the top, pinch together to secure and then plait the 3 lengths, crossing one over and under the other, bring lengths together by pressing at the end. Repeat with remaining dough.
4. Place onto a baking tray lined with baking paper and bake at 200°C for 40-45 minutes. Once cooked brush with glaze.

Glaze:

- 3 tablespoons sugar
- ¼ cup water
- 1 teaspoon gelatine

Place water, sugar and gelatine into a small saucepan. Stir over medium heat until sugar has dissolved, approximately 2 minutes.

Chelsa bun

1. Roll out the dough onto a floured surface into a 60cm X 30cm rectangle, about 2cm thick. Sprinkle with ½ cup mixed dried fruit or 1 green apple, peeled and chopped.
 2. Take the longest side and roll to form the shape of a swiss roll.
 3. Cut 5cm slices from the roll.
 4. Place decoratively into a greased and lined 20cm round cake tin. Overlap the slices to form a decorative bun. Brush with egg white. Allow to rise, about 15-20 minutes.
 5. Bake for 40-45 minutes in a hot oven at 200°C. Once baked brush with glaze.
- Note:** see 'Plaited Sweet Loaf' for recipe for glaze recipe.
6. When cold decorate top with icing. Mix together ½ cup icing sugar with 20ml water and pink food colouring.

Variations to this recipe:

Use this recipe to make hot cross buns. Divide the kneaded dough into 18 equal portions and roll. Place close together on a lined baking tray and mark a cross on each roll with a knife. Then pipe a mixture of stiff flour and water together over the top. Cover and allow to double in size, about 30 minutes. Bake in a hot oven at 200°C for 20-30 minutes. Brush with glaze while still hot. Eat warm with butter.

Recipes continued

Wholemeal Loaf

- 1 sachet (7g) dry yeast
- 2 tablespoons sugar
- 2 cups lukewarm water
- 30g butter, melted
- 2 cups plain flour
- 2 cups wholemeal flour
- 1 teaspoon salt

1. Combine the yeast, sugar, water and butter in a small bowl and allow to stand in a warm place until mixture begins to froth. About 10 minutes.
2. Insert the dough hooks into the mixer head (refer to page 4). Place sifted dry ingredients into the Mixmaster bowl.
3. With the bowl speed set on Low start mixing on Low speed (1-2), gradually add yeast mixture. Note, it will be necessary to scrape the sides of the bowl with a spatula. Knead on Medium speed (4) for 3-5 minutes, keep bowl speed on Low.
4. Continue the kneading process at Medium speed (4) until all ingredients are combined and the dough forms a ball. The dough will be soft and sticky. Remove dough from bowl using a spatula.
5. Place dough in a greased bowl, turning once to grease top of dough. Cover with plastic wrap, and let rise in a warm place until doubled in size (40-50 minutes).
6. Punch down, fold sides to centre and turn the dough over. Knead on a lightly floured surface. Cut dough in half. Shape into loaf pans. Cover with plastic wrap and allow to rise in a warm place until doubled in size (about 30 minutes). Preheat oven to 200°C.
7. Bake for approximately 30 minutes. Baked loaves sound hollow when tapped with the knuckles.

Variations to this recipe:

This dough can be used to make bread rolls, breadsticks, and as a basis for other wholemeal bakery goods. See variations for 'Basic White Loaf' recipes.

Note: Grain bread flour mix can be used as a substitute for plain and wholemeal flours.

Foundation Butter Cake

- 125g butter or margarine, softened
- ½ teaspoon vanilla extract
- ¾ cup caster sugar
- 2 eggs
- 2 cups self raising flour
- 1 cup milk

1. Preheat oven to 180°C. Grease and line a 20cm round cake tin.
2. Place butter in bowl and with bowl speed set on High start mixing on Medium speed (5-6). Add vanilla and sugar and cream on High speed (7-8) until light and creamy. Approximately 2 minutes.
3. Add eggs one at a time beating well between each addition.
4. Take bowl speed to Low and reduce mixing speed to Low (1-2), fold in sifted flour and milk alternately. Be careful not to use high speeds as flour will go everywhere! Mix for 3-4 minutes until cake batter is rich, smooth, thick and creamy.
5. Scrape batter into prepared pan. Bake for approximately 30-35 minutes or until cooked when tested with a skewer.

Note: When creaming butter or cream cheese use Low speeds (1-3) initially and make sure butter/cream cheese is chopped into cubes and added in small amounts until smooth and creamy. Butter and cream cheese should be at room temperature before beating. Once the desired quantity of butter/cream cheese has been added, slowly increase to the recommended higher speeds.

Recipes continued

Variations to this recipe:

Upsidedown Peach cake

1. Preheat oven to 180°C. Grease and line a 20cm round cake tin.
2. Select 4 small peaches. Cut each peach in half and remove their stones. Place cut side down in prepared cake tin. Sprinkle over 3 tablespoons white sugar and 20g chopped butter.
3. Follow steps 2 - 4 from the 'Foundation Butter Cake' recipe.
4. Spoon into cake tin. Level and bake for 40-45 minutes or until cooked when tested with a skewer. Allow cake to cool before removing from cake tin.
5. Serve peach side up. Makes 1 cake.

Variation:

Fresh pineapple slices, mango halves, peaches, pears or apricots can be used. Well drained tinned fruits such as plums can be used as well.

Serving suggestion: Serve cake cut into wedges and spoon a dollop of thick cream over the top.

Lemon or Orange Cake

Add the rind of one lemon or orange into the cake batter, and or with the addition of butter and sugar and fold 2 tablespoons of poppy seeds into the cake batter makes an interesting and tasty cake.

Coffee Crumble

Mix in 2 tablespoons of instant coffee powder into the cake batter. On top of the cake batter sprinkle with a mixture of 1 tablespoon butter, 2 tablespoons plain flour, 2 tablespoons sugar, ½ teaspoon of cinnamon and 2 tablespoons of instant coffee.

Chocolate Cake

60g dark chocolate - melted and added at the same time as the milk from the recipe above and mix well into the cake batter before baking.

Marble Cake

Divide batter into 3, leave one plain, add pink food colour to second portion and 2 tablespoons of cocoa, ⅓ teaspoon bicarbonate of soda and 1 tablespoon milk to the remaining cake batter. Drop spoonfuls of alternate colours into a 20cm ring tin.

Berry Cake

Add 2 cups of fresh, frozen or canned mixed berries to the top of the cake batter in tins before baking. Make sure that berries are well drained if canned.

Vanilla Sponge Cake

4 eggs, room temperature & separated
⅔ cup caster sugar
⅓ cup custard powder
½ teaspoon vanilla extract
⅔ cup plain flour, sifted
1 teaspoon baking powder

1. Grease and flour two deep 20cm cake tins. Preheat oven to 180°C.
2. Place the egg whites and sugar in the Mixmaster bowl and with the bowl speed set on High start mixing on High speed (10-11) for about 8 minutes or until very thick and creamy.
3. Stop the mixer. Remove beaters and bowl from the Mixmaster. Place bowl on bench and using a large metal spoon or a plastic spatula fold in the triple sifted dry ingredients. Take care not to over beat as you will lose the air bubbles and the mixture will be flat and tough.

Recipes continued

4. Spoon the mixture evenly into the prepared tins and bake for approximately 15 minutes or until the sponge comes away from the sides of the pans.
5. Once cooked run a knife around the sides of the cake to loosen the sponge from the pan and gently tap the bottom of the pan, turn out onto a cooling rack. Allow to cool before using.

Serving suggestion:

When cake is cool, cut and spread the base with your favourite jam and top with firmly whipped cream. Place one sandwich on top of the other to make 1 cake. Top with sifted icing sugar or use more whipped cream and top with fresh berries.

Fluffy Butter Frosting

250g butter or margarine, softened
3 cups icing sugar mixture
2-3 tablespoons milk
1½ teaspoon vanilla (optional)

1. Place butter in the Mixmaster bowl and with the bowl speed set on High start mixing on Medium speed (5) until light in colour.
2. Take bowl speed to Low and reduce mixing speed to Low (1), mix through remaining ingredients until combined.

Glaze Icing

3 tablespoons sugar
¼ cup water
1 teaspoon gelatine

1. Place all ingredients into a small saucepan. Stir over medium heat until sugar has dissolved, approximately 2 minutes.
2. Brush warm on top of baked sweet goods.

Cream Cheese Frosting

250g softened cream cheese
60g butter
1 teaspoon vanilla
3 cups icing sugar mixture

Place cream cheese, butter and vanilla in the Mixmaster bowl and with the bowl speed set on High start mixing on High speed (8) until smooth. Reduce speed to 1; gradually add the icing sugar mixture and mix until smooth. Spread over cooled cake.

Tip: To make passionfruit frosting add ¼ cup passionfruit pulp or to make lemon frosting, add 1 teaspoon finely grated lemon rind and 1 tablespoon lemon juice.

Cinnamon and Apple Tea Ring

DOUGH:

1 sachet (7g) dry yeast
2 tablespoons sugar
60g butter, melted
1¼ cup lukewarm milk
¾ cup water
4 cups plain flour
2 tablespoons sugar, extra
2 tablespoons powdered milk
1 teaspoon salt
1 cup sultanas

APPLE FILLING:

2 tablespoons water
¼ cup sugar
3 apples, peeled, cored and cubed
½ teaspoon cinnamon
¼ teaspoon vanilla extract
½ tablespoon cornflour, dissolved in ½ tablespoon water

Recipes continued

GLAZE:

3 tablespoons sugar

¼ cup water

1 teaspoon gelatine

1. Place water and sugar from the apple filling ingredients into a saucepan and dissolve sugar over medium heat. Increase heat and bring to the boil. Add apples and cook until slightly crisp in the centre. **DO NOT ALLOW APPLE PIECES TO LOOSE SHAPE.** Add cinnamon and vanilla. Stir in dissolved cornflour, and cook for a further minute until mixture thickens. Remove from heat and allow to cool.
2. Combine the first five dough ingredients in a small bowl and allow to stand in a warm place until mixture begins to froth. About 10 minutes.
3. Insert dough hooks into the mixer head (refer to page 4). Place sifted dry ingredients and sultanas into the Mixmaster bowl.
4. With bowl speed on Low start mixing on Low speed (1-2), gradually add yeast mixture. Note, it will be necessary to scrape sides of bowl with a spatula. Knead on Medium speed (4) for 4-5 minutes, and take bowl speed to High.
5. Continue the kneading process at Medium speed (4) until all ingredients are incorporated and dough forms a ball. Dough will be smooth and sticky. Remove dough from bowl using a spatula.
6. Place dough in a greased bowl, turning once to grease top. Cover with plastic wrap and let rise in a warm place until doubled in size (40-50 minutes).

7. Punch down, fold sides to centre and turn the dough over. Knead dough on a lightly floured surface until soft and smooth. Cut in half and roll dough out into a rectangle, approximately 30x20cm.
8. Spoon apple mixture along the long side of the dough and roll up tightly, Swiss Roll fashion, from the wide end.
9. Ease the roll into a greased ring tin and join ends. Cover, and allow to rise for approximately 40-50 minutes. Preheat oven to 200°C.
10. Bake for approximately 30-35 minutes or until golden brown. Remove from the tin and glaze while still warm.
11. To glaze place water, sugar and gelatine into a small saucepan. Stir over medium heat until sugar has dissolved, approximately 2 minutes.

Note: Repeat with the other dough half.

Variation to this recipe:

Apple Fruit Loaf

Mix 1 cup of mixed fruit into the dough instead of sultanas. Bring the longer sides together to meet at the middle. Score with a knife across the top. Brush with egg yolk and milk. Top with ½ cup of chopped walnuts. When cool top with icing if desired.

Recipes continued

Banana Cake

Serves 10

180g butter, room temperature, chopped

1 ½ cups raw sugar

2 eggs

2 ¼ cups self raising flour

½ teaspoon salt

1 teaspoon cinnamon

½ teaspoon nutmeg

½ cup buttermilk

1 teaspoon white vinegar

1 teaspoon vanilla essence

1 ½ cups very ripe mashed banana

1. Preheat oven to 180°C. Grease and line a 20cm baba pan.
2. Using the Mixmaster bowl with the bowl speed set on High, beat butter and sugar on High speed (7) until well combined. Add eggs, one at a time, beating well between each addition.
3. Take bowl speed to Low and reduce mixing speed to Low (1-2), add sifted dry ingredients and combined buttermilk, vinegar and vanilla in two batches. Add bananas and mix until combined.
4. Pour mixture into prepared tin and bake for about 40 minutes or until cooked when tested with a skewer.
5. Allow cake to cool in pan for 5 minutes before transferring to a wire rack to cool.

Glazed Orange Poppy Seed Cake

Serves 8

125g butter, softened

¾ cup caster sugar

1 tablespoon finely grated orange rind

2 eggs

1 cup self raising flour

⅓ cup milk

1 teaspoon vanilla extract

¼ cup poppy seeds

Glaze

2 teaspoons orange zest

½ cup orange juice

½ cup caster sugar

1. Preheat oven to 180°C. Grease and line and 20cm cake tin.
2. Using the Mixmaster bowl with the bowl speed set on High, cream butter, sugar and rind on High speed (7), until light and fluffy.
3. Add eggs one at a time, beating well between each addition.
4. Take bowl speed to Low and reduce mixing speed to Low (1), and add flour and milk in two batches; mix until just combined. Mix through poppy seeds.
5. Spread mixture into prepared tin and cook in oven for about 50 minutes or until cooked when tested with a skewer.
6. Meanwhile combine the zest, orange juice and sugar in a small saucepan. Stir over a low heat until the sugar has dissolved; bring to the boil, simmer for 2 minutes.
7. Turn cake out on to a cooling tray with a baking tray underneath. Using a wooden skewer, poke several holes into the cake then pour the hot syrup over the hot cake.

Recipes continued

Fritter Batter

Covers 8-12 fritters

- 1 cup plain flour
- 3 teaspoons baking powder
- Pinch of salt
- 1 egg
- ½ cup milk

1. Sift flour, baking powder and salt into the Mixmaster bowl, add egg and milk and with the bowl speed set on Low, start mixing on Low speed (2) until combined and mixture is smooth, approximately 1-2 minutes.
2. Dip your favourite prepared fruit or vegetable into batter and deep fry immediately.

Ingredient suggestions:

Raw or cooked fruits, cheese fritters, fried oysters.

Note: When deep frying fritters ensure that your oil is bubbling and very hot. Never cook fritters in oil that doesn't sizzle when food is placed into the deep fryer.

Mayonnaise

- 4 egg yolks
- 1 tablespoon dijon mustard
- 1½ tablespoons of lemon juice
- 1½ cups vegetable or olive oil

1. Combine eggs, mustard, and lemon juice in the Mixmaster bowl. With the bowl speed set on Low, start mixing on Low speed (1-2) slowly increasing to High speed (9). Gradually add the oil to the mixture in a long thin stream until the mixture becomes very thick and creamy in consistency.
2. Taste and adjust flavour of mayonnaise with salt and pepper.

Choux Pastry Puffs

Makes approx 30

- 80g butter
- 1 cup water
- 1 cup plain flour, sifted
- 4 eggs

1. Preheat oven to 220°C. Grease and line oven slides.
2. Place butter and water in a saucepan and bring to the boil.
3. Stir in flour. Cook stirring until dough leaves the side of the saucepan.
4. Cool slightly. Place mixture in the Mixmaster bowl and beat for 1 minute on Medium speed (5).
5. Add eggs one at a time and with bowl speed set on High, start mixing on Medium speed (5) until mixture is stiff and shiny. Once the last egg is added increase the speed to (7).
6. Drop tablespoon size portions onto prepared slides.
7. Bake for 15 minutes, then reduce heat to 160°C and bake for 35 minutes. Remove from oven, make a small slit in each puff and return to oven for a further 5-10 minutes. Cool, fill with sweet or savoury fillings and serve.

Note: These Choux Pastry Puffs freeze well. Once thawed, bake in 180°C oven for 5 minutes to crisp up.

Recipes continued

Fillings for the Choux Pastry Puffs:

Basic White Sauce

40g butter or margarine

40g flour

½ teaspoon salt

¼ teaspoon cayenne pepper

1 cup milk

1. Melt butter or margarine in a saucepan, but do not boil.
2. Remove from heat, add flour, salt and pepper, stir until smooth. Do not brown.
3. Add milk all at once. Stir until sauce boils and thickens.
4. Use one of the suggested fillings or divide into two or three.

Salmon Filling

1 x 125g tin salmon

2 teaspoons mayonnaise

lemon juice to taste

1. Drain salmon, and flake salmon into a bowl. Add mayonnaise, white sauce and mix well. Season with salt and pepper. Add lemon juice to taste. Pipe mixture into cooled puff's and serve warm or cold.

Asparagus Filling

1 small tin asparagus cuts, drained well and finely chopped

90g grated parmesan or romano cheese

1. Mix asparagus, white sauce and cheese until well combined. Season to taste with salt and pepper and pipe into pastry puffs. Serve hot or cold.

Mushroom and Bacon Filling

1 x 250g tin mushrooms, well drained and finely chopped

2 rashers cooked bacon, ham or prosciutto finely chopped

1. Mix together the white sauce, mushrooms and bacon in a small bowl until well combined. Pipe into pastry puffs and serve hot or cold.

Note: The white sauce is nice too, with freshly chopped mixed herbs and brie.

Sweet Pastry Cream

2 cups milk

1 vanilla bean, split and seeds scraped

6 egg yolks

$\frac{2}{3}$ cup caster sugar

$\frac{1}{3}$ cup cornflour

1. Bring the milk and vanilla bean and seeds to the boil in a small saucepan. Remove from heat once boiled. Remove vanilla bean.
2. Beat egg yolks, sugar and cornflour in the Mixmaster bowl, with bowl speed set on Low, start mixing on Medium speed (5-6) until thick. With the Mixmaster still running gradually beat in the milk mixture. Return custard mixture to saucepan, whisk over medium heat until mixture boils and thickens.
3. Transfer to a bowl and place a piece of plastic wrap onto the custard to stop a skin forming. Cool.
4. Pipe into puffs and drizzle with warmed chocolate.

Recipes continued

Crepes

- 1 ½ cups plain flour
- Pinch of salt
- 2 eggs
- 1¼ cups milk
- 1 tablespoon oil

1. Sift flour and salt into the Mixmaster bowl.
2. Add combined eggs and milk and with bowl speed set on Low, start mixing on Low speed (1). Increase speed to Medium (5) and beat well to remove any lumps.
3. Mix in oil and allow to stand for 1 hour.
4. Grease heated Sunbeam Skillet or Frypan. Pour about a ⅓ of a cup of batter into the pan to make each crepe.
5. Cook quickly until lightly brown. Turn and brown other side. Sprinkle with lemon juice and sugar. Roll and serve hot.

Serving suggestion:

- After crepe is cooked spread with nutella and roll up. Serve warm or serve cold (this one is great with the kiddies and big kids alike!).
- Smoked salmon with a slice of Camembert cheese, red onions and snow pea sprouts. Roll and serve with a fresh garden salad.

Waffles

Makes 6-8 waffles

- 2 cups self raising flour
- 2 eggs, separated
- ⅔ cup milk
- ½ cup water
- 90g butter, melted
- 2 tablespoons caster sugar

1. Preheat waffle maker or waffle iron.
2. Using the Mixmaster bowl with the bowl speed set on High add the sifted flour, egg yolks, milk, water and butter and start mixing on Medium speed (5) until smooth. Transfer to a large bowl. Wash and dry bowl and beaters.
3. Using the cleaned Mixmaster bowl and with the bowl speed set on Low, beat egg whites on Very High speed (11) until soft peaks form then gradually add the sugar and beat until the sugar is dissolved.
4. Fold the egg white mixture into the batter.
5. Bake in a greased, preheated waffle maker or waffle iron. Spoon approximately ¼ - ⅓ cup filling depending on the size of your waffle maker.
6. Cook for about 3 minutes or until waffles are browned and crisp. Serve with ice cream and syrup.

Recipes continued

Hazelnut & Cashew Torte

6 egg whites
4 egg yolks
¾ cup nutella
100g dark chocolate
½ cup plain flour
100g hazelnut meal
½ cup crushed cashews

Topping:

250g dark chocolate, chopped
250g cream
100g whole hazelnuts, toasted, skins removed
100g whole cashews, toasted

1. Preheat oven 160°C. Grease and line 20cm round cake tin.
2. Using the Mixmaster bowl with the bowl speed set on Low, mix egg yolks, nutella and melted chocolate together on Low speed (1). Add flour, hazelnut meal and crushed cashews until the mixture has formed even sized crumbs. Transfer to a large bowl.
3. In the Mixmaster bowl and with the bowl speed set on High, whisk egg whites until stiff peaks form, on Very High speed (10-12). Remove from bowl and set aside.
4. Pour into the prepared cake tin and bake 40-45 minutes.
5. Allow to cool in pan for 10 minutes before removing cake from pan and cool on a wire rack.
6. Combine the chocolate and cream together. Microwave on 100% for 20 seconds at a time, stirring each time until the chocolate has melted and the mixture has combined. Refrigerate until mixture starts to set then spread over cake.
7. Top with cashews and hazelnuts. Serve in thin wedges.

Two Tier Pavlova with Mixed Berries Serves 10

6 egg whites
1 ½ cups caster sugar
3 teaspoons vinegar
1 ½ tablespoons cornflour
2 teaspoons rosewater
red food colouring (optional)
600ml thickened cream
300g fresh or frozen mixed berries

1. Preheat oven to 120°C. Line two baking trays with baking paper.
2. Ensure the Mixmaster bowl is thoroughly cleaned, set bowl speed on High and beat egg whites on Very High speed (11) until stiff.
3. Gradually add the sugar, 1-2 tablespoons at a time, making sure that the sugar has dissolved between each addition. This will take about 8-10 minutes. Scrape the sides down if necessary.
4. Once the sugar has been added take the bowl speed to Low and reduce mixing speed to Low (2), and fold in vinegar, cornflour, rosewater and 3-4 drops of colouring until combined.
5. Spread mixture into two even sized disks approximately 23cm wide. Bake in oven for 1 hour. Turn oven off and allow pavlova to cool with the door slightly ajar.
6. Using the Mixmaster bowl set the bowl speed to Low and beat cream on Medium speed (5) until thickened.
7. Once cool, place one pavlova onto a serving plate. Top with half the cream and half the berries, top with the other pavlova and the remaining cream and berries.

Tip: If using frozen berries, thaw the berries on absorbent paper to soak up the extra juices.

Chocolate Espresso Mousse Cappuccino

Serves 4

160g dark chocolate, chopped
1 x 30ml shot espresso, cooled
300ml thickened cream
extra whipped cream, to serve

1. Melt chocolate in a bowl over a saucepan of simmering water; cool.
2. Combine cooled espresso and thickened cream in the Mixmaster bowl. With the bowl speed set on High start mixing on High speed (10) until thickened. Reduce to Low speed (1) and add melted chocolate until just combined.
3. Spoon mixture into stainless cups or other small coffee cups and chill for 3 hours or overnight.
4. To serve spoon whipped cream over mousse and dust with chocolate.

Tip: To chill quickly place cups into fridge while preparing mousse.

Passionfruit Cheesecake

Serves 10

250g plain biscuits
125g butter, melted
500g cream cheese, room temperature, cubed
250ml thickened cream
3 eggs
½ cup caster sugar
⅓ cup passionfruit pulp (approx 3 passionfruit)

1. Grease and line base of a 20cm springform.
2. Blend or process biscuits until fine. Place biscuit crumbs and melted butter in a bowl; mix well until combined. Press crumb mixture into the base and sides of a prepared pan. Place on a baking tray and refrigerate for 30 minutes.
3. Place cream cheese into the Mixmaster bowl. With the bowl speed set on High start mixing on High speed (8) for about 3 minutes or until creamy. Add sugar and mix for a further 2 minutes. Add eggs one at a time, beating well between each addition. Scrape sides of bowl if necessary.
4. Take the bowl speed to Low and reduce mixing speed to Low (3), add cream and passionfruit. Beat until the cream has been mixed through and there are no lumps.
5. Pour filling into crust and bake in oven at 160° for approximately 50 minutes or until firm. Cool in oven with door ajar. Refrigerate for several hours before serving.

Recipes continued

Fluffy Pikelets

Makes approx 12

- 1½ cups self raising flour
- Pinch of salt
- 1 teaspoon bicarbonate of soda
- 2 tablespoons sugar
- 1 egg
- 1¼ cups milk
- 4-5 drops vanilla extract
- 40g butter or margarine

1. Sift flour, salt and soda into the Mixmaster bowl. Add sugar, egg, milk and vanilla. With the bowl speed set on Low speed, start mixing on Low speed (1-2) until combined.
2. Increase to Medium speed (5) and beat for 1-2 minutes until smooth.
3. Fold in melted butter on Low speed (1). Place spoonfuls onto a hot Sunbeam Frypan and cook until browned on both sides.

Note: Suitable to freeze and reheat.

Serving suggestions:

- Serve pikelets hot or cold.
- Serve with whipped cream and jam for a sweet treat.
- For a savoury treat, top with vegemite & butter or ham & cheese.
- Add freshly chopped herbs to the batter and serve cooked pikelets with cream cheese, smoked salmon and caviar.

Cornflake Cookies

- 125g butter or margarine
- ½ cup caster sugar
- 1 egg
- ½ teaspoon vanilla essence
- ½ cup currants
- ½ cup desiccated coconut
- 1¼ cups self raising flour
- Pinch of salt
- 2 cups cornflakes, crushed

1. Preheat oven to 180°C. Grease, line baking trays.
2. Using the Mixmaster bowl and with the bowl speed set on Low, cream together butter and sugar on Medium speed (6).
3. Add egg and beat well.
4. Reduce to Low speed (1) and add vanilla, currants and coconut.
5. On Low speed (1) fold in flour and salt in two portions, until mixture is well combined.
6. Spread cornflakes onto a piece of paper and drop teaspoonfuls of mixture onto cornflakes. Roll to coat.
7. Place onto prepared slides and bake for 15 minutes. Allow to cool on trays.

Recipes continued

Chocolate Chip Cookies Makes approx 30

125g butter, softened
½ cup firmly packed soft brown sugar
½ cup caster sugar
1 teaspoon vanilla extract
1 egg
1 ¾ cup self raising flour
1 cup choc chips

1. Preheat oven to 180°C. Line 2 baking trays with baking paper.
2. Place butter, sugars and vanilla in the Mixmaster bowl. With the bowl speed set on High start mixing on Low speed (1-2) until the butter starts to break up and combine with the sugars, then increase mixing speed to High (7) until light and creamy.
3. Add egg and mix and beat until well combined. Reduce mixing speed to Low (1) and mix through flour and chocolate chips.
4. Roll tablespoon amounts into balls and place onto baking tray press lightly with the back of a fork. Ensure that the cookies are well spaced to allow for spreading.
5. Bake in oven for about 10 -13 minutes or until golden. Do not overcook. Cool on wire racks.

Quick Cup Cakes Makes 12

60g butter or margarine
1¼ cups self raising flour
½ cup sugar
2 eggs
¼ cup milk
1 teaspoon vanilla essence

1. Preheat oven to 220°C and place patty cases into patty tins and set aside.
2. Using the Mixmaster bowl and bowl speed set on Low, place all ingredients into the bowl and beat until combined, start mixing on Low speed (1), slowly increasing to Medium speed (5).
3. Place spoonfuls of batter into the patty cases and bake for 12-15 minutes.
4. Allow to cool and decorate as desired.

Variations to this recipe:

Top the cake batter in the patty cases with frozen berries before baking.

Serving suggestion:

When patty cakes are cooked drizzle with icing sugar and top with a small eatable decoration like marshmallows.

Butterfly cakes

Cut the tops off the patty cakes and cut in-half. Top with a small spoonful of cream or thick custard. Place cake halves back into the centre of the cup cakes facing up to create wings. Dust with icing sugar.

Recipes continued

Meringues

2 egg whites
90g caster sugar
90g icing sugar

1. Preheat oven to 120°C. Grease two oven slides with baking paper.
2. Using the Mixmaster bowl and the bowl speed set on Low, beat egg whites until stiff but not dry, on Very High speed (10-12).
3. On Very High speed (10-12) add caster sugar gradually, beating well.
4. Reduce to Low speed (1) and fold in icing sugar. Mix until stiff and shiny.
5. Using a star shaped nozzle, pipe small meringues onto the prepared slide. If you do not have a piping bag use two teaspoons. Decorate if desired. Bake for 10 minutes, reduce heat to 100°C and continue cooking for 20-25 minutes.
6. When cold, join in pairs with icing (optional).

Marshmallows

Makes 24 pieces

2 tablespoons gelatine
½ cup cold water
2 cups sugar
1 cup boiling water
pink food colouring (optional)
¾ cup light toasted desiccated coconut

1. Sprinkle gelatine over cold water; gently stir through. Place sugar and boiling water in a large saucepan. Stir over a low heat until the sugar has dissolved. Bring mixture to the boil; stir in gelatine mixture. Boil mixture, uncovered, over a medium heat, for 10 minutes. Cool to room temperature.
2. Place mixture into the Mixmaster bowl; add red food colouring. With bowl speed set on High start mixing on Very High speed (12) for about 10 minutes or until very thick and creamy.
3. Pour mixture into a 20cm x 30cm lamington tin which has been rinsed with cold water. Refrigerate until firm.
4. Cut marshmallow into squares with a wet knife. Toss in toasted coconut.

Recipes continued

Serving suggestion:

Marshmallow's are great served in hot chocolates or coffee. They are a fun afternoon treat for the kids and can be used to make rocky road.

Rocky Road

For rocky road combine some mixed nuts, and dried fruit and marshmallows. Mix with melted chocolate and spread into a greased and lined baking sheet. Set in the fridge if it's a hot day. Cut into slices and serve.

Nougat

2 cups sugar
1 cup liquid glucose
¼ cup honey
Pinch of salt
¼ cup water
2 egg whites
1 teaspoon vanilla
40g butter, melted
100g blanched almonds, lightly toasted

1. Grease and line a 28 x 18cm lamington tin.
2. Place sugar, glucose, honey, salt and water in a saucepan. Stir over low heat until sugar is dissolved then bring to the boil. Cook for 20 minutes until mixture forms a hard ball when tested in a small amount of water. Be sure not to discolour.
3. Using the Mixmaster bowl and bowl speed set on High, whisk the egg whites until stiff on Very High speed (12). Pour 1 cup of hot syrup slowly into the egg whites on High speed (7-8). Continue beating until mixture is thick and holds its shape.

4. Continue boiling syrup until brittle threads form when tested in a small amount of cold water.
5. Pour in a little of the remaining syrup into meringue while beating on High speed (7). Continue beating until very thick. Add the butter and nuts, continue beating while pouring in the last remaining syrup, let run until it is combined.
6. Spoon into prepared tin and refrigerate until firm.
7. Turn out onto a board and with a sharp knife, cut into squares.

Note: Liquid glucose can be bought from health food stores or pharmacies.

Recipes continued

Hot Cross Buns

Makes 18

Dough

- 1 sachet dry yeast
- 2 tablespoons sugar
- 60g butter, melted
- 1¼ cup lukewarm milk
- ¾ cup water
- 4 cups plain flour
- 2 tablespoons sugar, extra
- 2 tablespoons powdered milk
- 1 teaspoon salt
- 1 cup sultanas

Crosses

- ½ cup plain flour
- ¼ cup water

Glaze

- 3 tablespoons sugar
- ¼ cup water
- 1 teaspoon gelatin

1. Combine the first five ingredients in a small bowl and allow to stand in a warm place until mixture begins to froth. About 10 minutes.
2. Insert dough hooks into the mixer head (refer to page 4). Place sifted dry ingredients, including the sultana's into the Mixmaster bowl.
3. With the bowl speed set on Low, start mixing on Low speed (1-2), gradually add yeast mixture. Note that it will be necessary to scrape sides of bowl with a spatula. Knead on Medium speed (4) for 3-4 minutes, keep bowl speed on Low.

4. Continue the kneading process until all ingredients are incorporated and dough forms a ball.
5. Place dough in a greased bowl, turning once to grease top of dough. Cover, and let rise in a warm place until doubled in size (40-50 minutes).
6. Preheat oven to 220°C and grease a baking tray.
7. Punch down, fold sides to centre and turn the dough over. Remove the dough from the bowl and place onto a well floured surface. Lightly knead dough with the palm of your hands until smooth and elastic. Divide dough into 18 equal portions and shape into round, smooth balls.
8. Position the dough balls closely together onto the baking tray. Cover loosely for approximately 10 minutes.
9. For the crosses, combine the flour and water to form a batter and pipe crosses on the tops of the buns.
10. Bake for approximately 20-25 minutes until golden brown.
11. Whilst the buns are baking prepare the glaze. Place the water, sugar and gelatin into a small saucepan and stir over a medium heat until sugar has dissolved, approximately 2 minutes. Glaze the buns while they are still warm.

Recipes continued

Christmas Cake

- 2¼ cups raisons, chopped
- 3 cups sultanas
- 1¾ cup currants
- 1½ cups glace figs, chopped
- ½ cup glace cherries, halved
- ⅓ cup golden syrup
- ½ cup brandy
- 250ml olive oil
- 1 cup firmly packed soft brown sugar
- 5 eggs
- 1¼ cups plain flour
- 1 teaspoon mixed spice
- 2 tablespoons brandy, extra

1. Combine fruit, syrup and brandy in a bowl; mix well. Cover, stand overnight.
2. Preheat oven to 150°C. Grease and line base and sides of a 19cm square cake tin with 3 layers of baking paper.
3. With bowl speed set on High, beat oil and sugar in the Mixmaster bowl on High speed (7-9) until combined. Add eggs one at a time, beating well between each addition. Add fruit mixture, flour and mixed spice. With the bowl speed set on Low, beat on Low Speed (1-2) until mixture is combined.
4. Pour into prepared pan and bake in slow oven for about 4 hours or until cooked when tested with a thin metal knife (there should be no raw cake mix on knife).
5. Remove cake from oven and brush with extra brandy. Cover pan with foil and leave to cool in pan upside down.

Festive Shortbread

- 250g butter
- 2 tablespoons maple syrup
- ⅓ cup caster sugar
- 2 cups plain flour
- ½ cup corn flour
- 100g choc melts, melted

1. Preheat oven to 200°C. Grease and line two baking trays.
 2. In the Mixmaster bowl and with the bowl speed set on Low, cream the butter, syrup and sugar on Medium speed (4-6) until combined.
 3. Add the flours and mix on Low speed (2-3) until the mixture is combined well.
 4. Turn the mixture out onto a floured surface and lightly knead to combine. Press dough out to a 2cm thickness and using your favourite festive cutter, cut into shapes.
- TIP:** In very hot weather you may want to chill your dough for 10 minutes in the refrigerator.
5. Place shapes onto baking trays and bake for about 12 minutes or until just golden. Cool on trays.
 6. Drizzle with chocolate once cooled.

'Sunbeam', and 'Mixmaster' are registered trademarks of Sunbeam Corporation.

Made in China. Due to minor changes in design or otherwise, the product may differ from the one shown in this leaflet. Backed by Sunbeam's 12 Month Replacement Guarantee and National Service Network.

© Copyright. SUNBEAM CORPORATION LIMITED 2005.

(INCORPORATED IN N.S.W.) A.C.N. 000 006 771

Sunbeam Corporation is a division of GUD Holdings Ltd.

For more information or advice on this or any other Sunbeam appliance, visit www.sunbeam.com.au or contact the Sunbeam Consumer Service Line.

Australia 1800 025 059

New Zealand (09) 912 0747.

Sunbeam

Consumer Hotline

Australia

1800 025 059

New Zealand

0800 786 232

www.sunbeam.com.au

 is a registered Trademark of Sunbeam Corporation Limited. ACN 000 006 771.

© Sunbeam Corporation Limited 2005.