

# PLYLE®



**FOR CAR AND MARINE USE**



[www.pyleaudio.com](http://www.pyleaudio.com)

**PLMRA400**  
***Waterproof Marine 400W 4 Channel Amplifier***  
***User's Manual***

# INTRODUCTION

Thank you for purchasing the PYLE PLMRA 400 High Speed Power Amplifier .  
The PLMRA 400 has been designed using the latest electronic technology available.

The PLMRA 400 is with engineered features allowing you to produce high quality stereo reproduction in mobile applications. This innovative system has been designed a 12 volts DC negative ground power supply. Easy installation with mounting hardware is provided.

The PLMRA 400 has two input levels. The high or low impedance input can be connected to units which incorporate BTL circuitry or common-ground types.

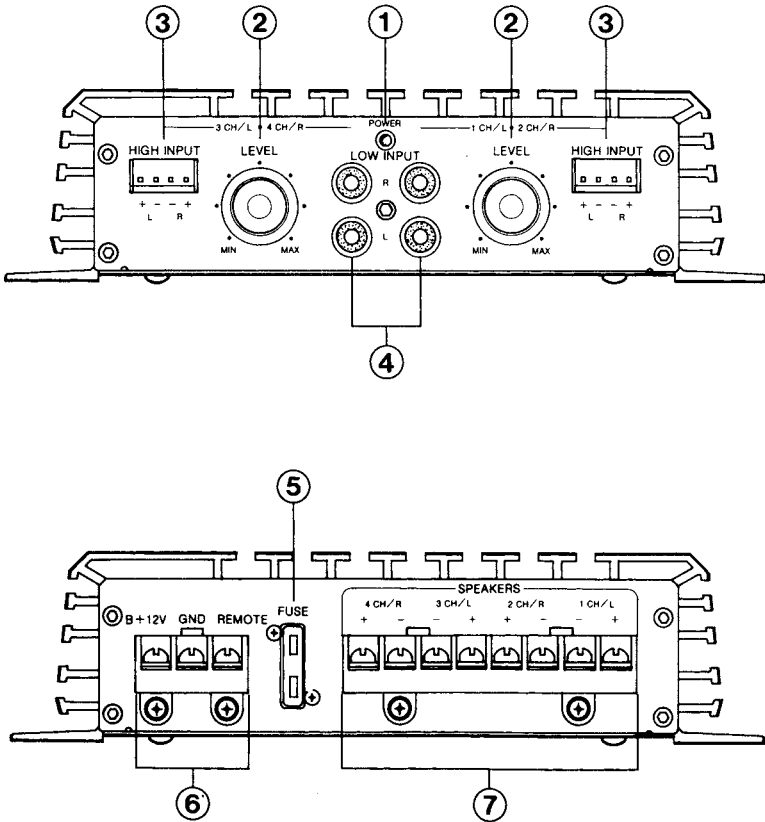

Figure 1

# FUNCTIONS

---

## 1.POWER ON LED

Lights up when the remote on system is energized.

## 2.INPUT GAIN CONTROL

Adjust high impedance input gain from 1 V to 300mV for best matching with PREAMP output for your car stereo.

## 3.LOW IMPEDANCE INPUT (HIGH LEVEL INPUT)

This unit is provided with two terminal inputs (Front & Rear) for LOW impedance. If Your car stereo has four speaker outputs (LF,RF,LR,RR). Wire input as per FIG. 3 & FIG 3A. If your car stereo has two speaker outputs, please wire as per FIG 4 & FIG 4A.

## 4.HIGH IMPEDANCE INPUT (LOW LEVEL INPUT)

This unit is provided with gold plated RCA input jacks for high impedance. Couple the RCA input with the car stereo output using RCA type connector cables. If your stereo has only left and right 2 channels outputs. You must use a Y-adaptor for connection (FIG 2).

## 5.POWER FUSE

Power fuse protects both this amplifier and the automobile electrical system from wrong electrical conditions.

## 6.POWER SUPPLY TERMINAL

Connect the +12V DC power supply wire into this terminal. By lugs and screws accessible at the panel of this amplifier (Fig. 5).

### A.BATT +

Connect +12VDC power supply wire into this terminal from the (+) terminal of the battery.

### B.GROUND

Ground terminal connects the ground wire from the chassis of the automobile.

### C.REMOTE

Remote terminal connects the control wire which provides remote turn-on and off of the amplifier by the RADIO/CASSETTE players power antenna wire.

## 7.SPEAKERS TERMINALS

Speakers can be easily connected to signal barrier strip. You may use 4 to 8 ohms speakers. Before connecting, please check speaker connection diagrams.

# ELECTRICAL & AUDIO CONNECTIONS

## A. STEREO INPUT CONNECTION

### 1. High impedance input.

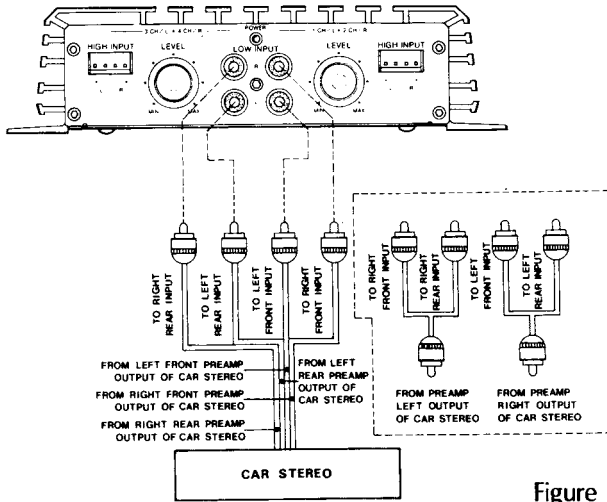

Figure 2

### 2. Low impedance (BTL or Common Ground) Input

#### a. Four Speaker Output Mode

##### a-1. Floating Ground Type

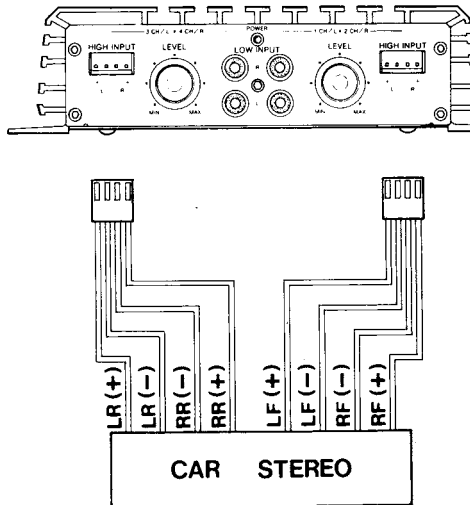

Figure 3

# ELECTRICAL & AUDIO CONNECTIONS

## a-2. Common Ground Type

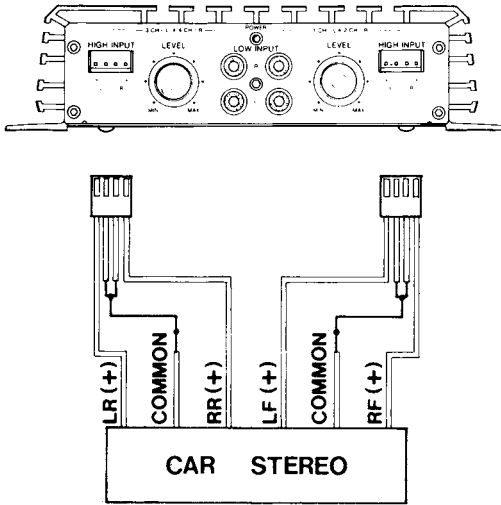

Figure 3A

## b. Two Speaker Output Mode

### b-1. Floating Ground Type

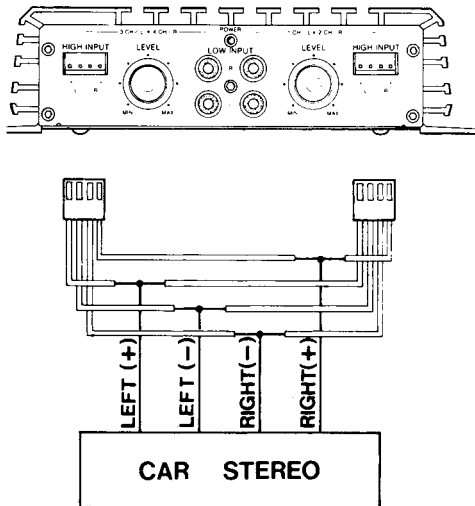

Figure 4

# ELECTRICAL & AUDIO CONNECTIONS

## b-2. Common Ground Type

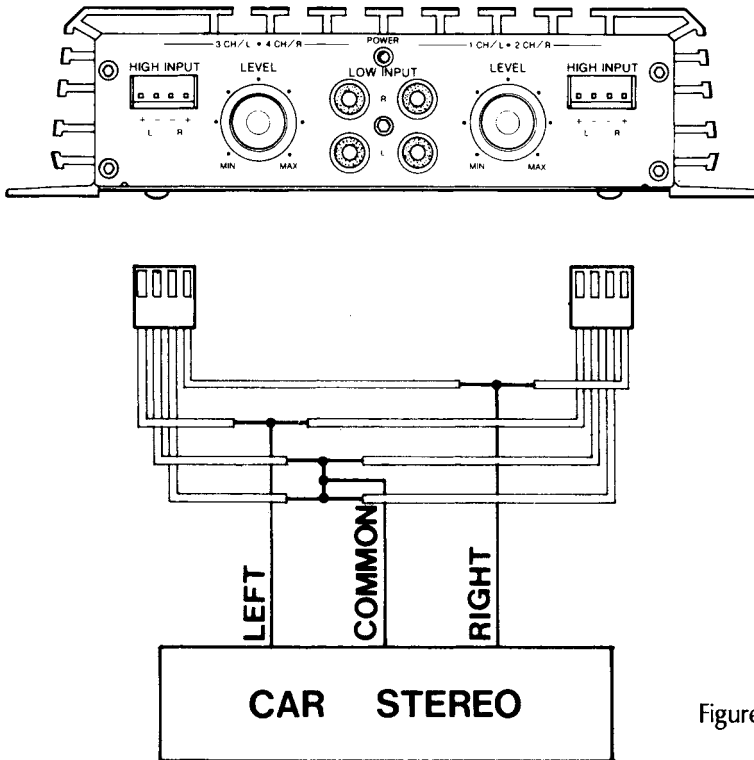

Figure 4A

NOTE: High and low impedance input can not be used at same time.

### B. SPEAKER CONNECTION

Connect the speaker output terminals to the corresponding speakers. (Figure 5) The speakers must be high quality and capable of handling high power. Separated return paths and strong wires are required. (Fig. 5)

NOTE: This amplifier has built-in short circuit protection. If you mistakenly connect any speaker wires to ground, or positive power (+) and (-) Wires short together, the protection circuit will operate automatically and cut-off output. In case of this, you must switch OFF the whole system immediately double check speaker wire connections and isolation before switching on the amplifier again.



# INSTALLATION

---

This amplifier comes complete with mounting hardware, if the unit is used in the line level (high impedance) mode, it is recommended to use gold plated RCA connection cables with the length as short as possible and mount the unit as close as possible to the receiver. This will lower the chance of stray magnetic pick up that may cause noise in the system.

1. Choose a suitable location.
2. Check the clearance behind and above the mounting area.
3. Wire unit according to the proper wiring diagram.
4. Using the hardware provided, attach the unit to mounting surface.

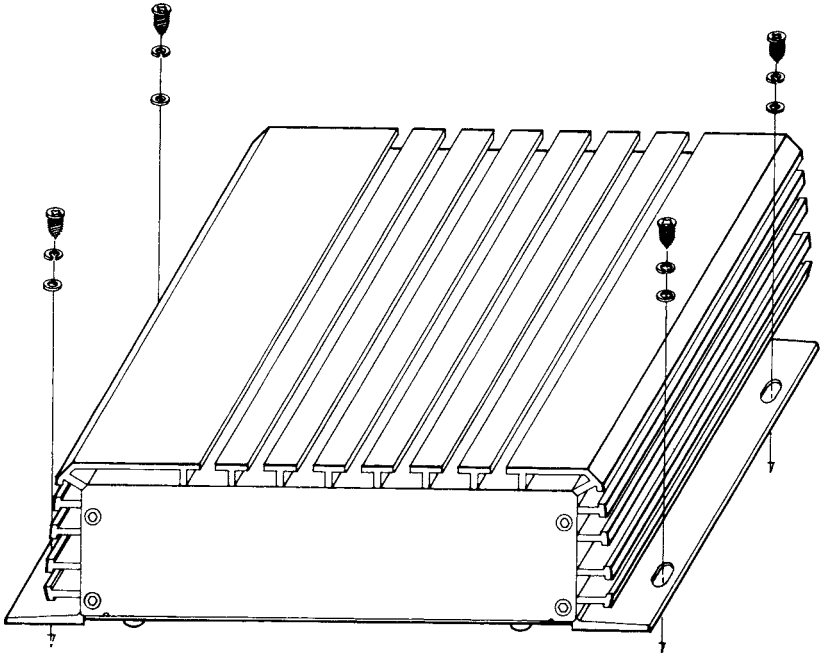



# MAINTENANCE

---

Your PYLE power Amplifier is an example of superior design and craftsmanship. The following suggestions will help you care for your amplifier so you can enjoy it for years.



Keep the amplifier dry. If it gets wet, wipe it dry immediately. Liquids can contain minerals that corrode electronic circuits.



Use and store the amplifier only in normal temperature environments. Temperature extremes can shorten the life of electronic devices and distort or melt plastic parts.



Handle the amplifier gently and carefully. Dropping it can damage circuit boards and cases and can cause the amplifier to work improperly.



Keep the amplifier away from dust and dirt, which can cause premature wear of parts.



Wipe the amplifier with a damp cloth occasionally to keep it looking new. Do not use harsh chemicals, cleaning solvents, or strong detergents to clean the amplifier.

## TESTING AND SPECIFICATONS

---

1. After all the connections have been made, turn on your stereo and listen for the amplifier to turn on. If there are any unusual noises from the speakers then turn the system off and recheck all the wiring.
2. After you have connected your radio or equalizer to the amplifier, you may adjust the gain control to match the output level of your radio.
  - (A)Set the volume control on your radio to 2/3 position.
  - (B)Adjust the gain control for an average listening level.
  - (C)Turn the radio volume all the way down and listen for background noise.
  - (D)Start your vehicle and listen for electrical noise.
  - (E)Making fine adjustments to the sensitivity can reduce background noise and some engine noise.
  - (F)CAUTION:Never turn the sensitivity up any farther than you need to get clear sound at 2/3 volume.
  - (G)This adjustment only needs to be made once.

## SPECIFICATIONS

1. Output power  
@14.4 V.D.C. 1KHZ.....100 WX4 Max
2. Frequency Response .....15-30K Hz ( ± 3dB)
3. Input Impedance.....10K ohms (Low Level)  
100 ohms (High Level)
4. Input Sensitivity  
High Level.....2.5v  
Low Level.....250mv
5. Power Supply Voltage.....DC 14.4V negative ground (10.5-16V)
6. Matching Speaker Impedance.....4-8 ohms
7. Maximum Current Draw.....10A
8. Dimensions.....7.87''W x 2''H x 8.0''L
9. Net Weight.....3.30 (lbs)



# limited warranty policy amplifiers

**You must also include the following items:**

- A copy of your sales receipt or other proof of purchase
- A brief letter indicating the problem you are experiencing
- include in your letter your return address, daytime phone number, and R.A. number
- also include a check or money order for \$18.00 for return shipping, handling, and insurance, or provide your Visa/MC number with expiration date.

Our obligation under this warranty is limited to the repair or replacement of the defective unit when it is returned to us prepaid. This warranty will be considered void if the unit was tampered with, improperly serviced, or subject to misuse, neglect, or accidental damage.

All Pyle products are carefully constructed and thoroughly tested before shipment. Products purchased in the USA are warranted to be free of defects in material and workmanship for two (2) years from the date of purchase. This warranty is limited to the original retail purchase.

Should the product fail due to factory defects in material or workmanship, your unit will be repaired or replaced at the sole discretion of Pyle.

To obtain warranty service you must first call our Consumer Return Hotline number at (718) 236-6948 to obtain a Return Authorization number. This R.A.# must appear on the outside of your package and on all paperwork relating to your return.

When returning a product to us for warranty service it must be carefully packed and shipped prepaid to:

**R.A.#**  
**Pyle Service Center**  
**1600 63rd Street**  
**Brooklyn, NY 11204**

**www.pyleaudio.com**