



LTP F SERIES
LINE THERMAL PRINTER MECHANISM
TECHNICAL REFERENCE

U00060419201

Seiko Instruments Inc.

LTP F SERIES LINE THERMAL PRINTER MECHANISM TECHNICAL REFERENCE

Document Number U00060419201

First Edition August 2001
Second Edition February 2002

Copyright © 2001, 2002 by Seiko Instruments Inc.
All rights reserved.

Seiko Instruments Inc. (SII) has prepared this manual for use by SII personnel, licensees, and customers. The information contained herein is the property of SII and shall not be reproduced in whole or in part without the prior written approval of SII.

SII reserves the right to make changes without notice to the specifications and materials contained herein and shall not be responsible for any damages (including consequential) caused by reliance on the materials presented, including but not limited to typographical, arithmetic, or listing errors.

SII is a trademark of Seiko Instruments Inc.

PREFACE

This reference manual describes the specifications and basic operating procedures for the LTP F Series Thermal Printer Mechanism (hereinafter referred to as “printer”).

The LTP F series has the following two types of printers that are classified by their paper width.

LTPF247A-C432

LTPF347A-C576

This manual usually describes information common to any printer, and each information with the name if information is different.

Chapter 1 “Precautions” describes safety, design and operational precautions. Read it thoroughly before designing so that you are able to use the product properly.

SII has not investigated the intellectual property rights of the sample circuits included in this manual. Fully investigate the intellectual property rights of these circuits before using. In particular, SII reserves the industrial property rights for the Heat Storage Simulation described in Chapter 3. Using it for the other printer is infringement on the industrial property rights.

TABLE OF CONTENTS

Section		Page
CHAPTER 1 PRECAUTIONS		
1.1	SAFETY PRECAUTIONS	1-1
1.2	DESIGN AND HANDLING PRECAUTIONS	1-2
1.2.1	Design Precautions	1-2
1.2.2	Handling Precautions	1-5
1.2.3	Precautions on Discarding	1-6
CHAPTER 2 FEATURES		
CHAPTER 3 SPECIFICATIONS		
3.1	GENERAL SPECIFICATIONS	3-1
3.2	HEAT ELEMENT DIMENSIONS	3-3
3.2.1	Heat Element Dimensions for the LTPF247	3-3
3.2.2	Heat Element Dimensions for the LTPF347	3-4
3.3	PAPER FEED CHARACTERISTICS	3-5
3.4	STEP MOTOR CHARACTERISTICS	3-6
3.4.1	Motor Drive Circuit	3-7
3.4.2	Motor Timing	3-9
3.4.3	Motor Driving Precautions	3-10
3.5	THERMAL HEAD	3-14
3.5.1	Structure of the Thermal Head (LTPF247)	3-15
3.5.2	Printed Position of the Data (LTPF247)	3-16
3.5.3	Thermal Head Electrical Characteristics (LTPF247)	3-17
3.5.4	Structure of the Thermal Head (LTPF347)	3-18
3.5.5	Printed Position of the Data (LTPF347)	3-19
3.5.6	Thermal Head Electrical Characteristics (LTPF347)	3-20
3.5.7	Timing Chart	3-21
3.5.8	Head Resistance	3-21
3.5.9	Head Voltage	3-22
3.5.10	Peak Current	3-22
3.6	CONTROLLING THE HEAD ACTIVATION (DST) PULSE WIDTH	3-23
3.6.1	Calculation of the Head Activation Pulse Width	3-23
3.6.2	Calculation of the Applied Energy	3-23
3.6.3	Adjustment of the Head Resistance	3-24
3.6.4	Head Activation Pulse Term Coefficient	3-24
3.6.5	Heat Storage Coefficient	3-25
3.6.6	Thermistor Resistance	3-26
3.6.7	Detecting Abnormal Temperatures of the Thermal Head	3-28

Section	Page
3.7 PAPER DETECTOR	3-29
3.7.1 General Specifications	3-29
3.7.2 Sample External Circuit.....	3-30
3.8 PLATEN POSITION DETECTOR	3-31
3.8.1 General Specifications	3-31
3.8.2 Sample External Circuit.....	3-31

CHAPTER 4 CONNECTING TERMINALS

4.1 THERMAL HEAD CONTROL TERMINALS.....	4-2
4.2 MOTOR CONTROL TERMINALS.....	4-5

CHAPTER 5 DRIVE METHOD

CHAPTER 6 HOUSING DESIGN GUIDE

6.1 SECURING THE PRINTER	6-1
6.1.1 Printer Mounting Dimensions	6-1
6.1.2 Recommended Screws	6-3
6.1.3 Precautions for Securing the Printer	6-3
6.2 LAYOUT OF PRINTER AND PAPER	6-4
6.3 WHERE TO MOUNT THE PAPER HOLDER	6-5
6.4 WHERE TO MOUNT THE PLATEN UNIT.....	6-5
6.5 WHERE TO MOUNT THE PLATEN RELEASE KNOB	6-6
6.6 WHERE TO MOUNT THE PAPER CUTTER	6-6

CHAPTER 7 APPEARANCE AND DIMENSIONS

CHAPTER 8 LOADING/UNLOADING PAPER AND HEAD CLEANING

8.1 LOADING/UNLOADING PAPER PRECAUTIONS.....	8-1
8.2 HEAD CLEANING PRECAUTIONS AND PROCEDURE	8-4
8.2.1 Head Cleaning Precautions.....	8-4
8.2.2 Head Cleaning Procedure	8-4

Section

Page

CHAPTER 9 PERIPHERALS

9.1	AUTOCUTTER UNIT	9-1
9.1.1	Installation Method	9-2
9.1.2	Clearing a Paper Jam in the Autocutter	9-4
9.1.3	Consideration for Outer Case Design	9-5
9.1.4	Considerations for Using	9-7
9.1.5	Appearance of the Printer with the Autocutter Installed	9-8

FIGURES

Figure	Page
3-1 Heat Element Dimensions (LTPF247)	3-3
3-2 Print Area (LTPF247)	3-3
3-3 Heat Element Dimensions (LTPF347)	3-4
3-4 Print Area (LTPF347)	3-4
3-5 Sample Drive Circuit.....	3-7
3-6 Input Voltage Signals for the Sample Drive Circuit	3-8
3-7 Motor Start/Stop Timing	3-9
3-8 Sample of Motor Current Control	3-13
3-9 Thermal Head Block Diagram (LTPF247).....	3-15
3-10 Printed Position of the Data (LTPF247)	3-16
3-11 Thermal Head Block Diagram (LTPF347).....	3-18
3-12 Printed Position of the Data (LTPF347)	3-19
3-13 Timing Chart.....	3-21
3-14 Thermistor Resistance vs. Temperature	3-26
3-15 Sample External Circuit of the Paper Detector.....	3-30
3-16 Sample External Circuit of the Platen Position Detector	3-31
4-1 Thermal Head Control Terminals	4-2
4-2 Terminals on the Motor Connector.....	4-5
5-1 Timing Chart for Driving Using Two Divisions	5-2
6-1 Printer Mounting Dimensions	6-2
6-2 Layout of Printer and Paper.....	6-4
6-3 The Platen Unit Mounting Position	6-5
7-1 Appearance and Dimensions (LTPF247).....	7-2
7-2 Appearance and Dimensions of the Platen Unit(LTPF247)	7-3
7-3 Appearance and Dimensions (LTPF347).....	7-4
7-4 Appearance and Dimensions of the Platen Unit (LTPF347)	7-5
8-1 Loading Paper (1).....	8-1
8-2 Loading Paper (2).....	8-2
8-3 Loading Paper (3).....	8-2
8-4 Head Cleaning Procedure	8-4
9-1 Installing the Autocutter Unit (Movable blade unit).....	9-2
9-2 Fixing Blade Unit	9-3
9-3 Installing Autocutter Unit (Fixing blade unit)	9-3
9-4 Clearing a Paper Jam in the Autocutter	9-4
9-5 Outer Case Design.....	9-5
9-6 Outer Case Design sample (Mechanism Side)	9-6
9-7 Using the Paper Effectively When Cutting	9-7
9-8 Appearance of the Printer with the Autocutter Installed (LTPF247 with ACUF224A)	9-8
9-9 Appearance of the Printer with the Autocutter Installed (LTPF247 with ACUF224B)	9-9
9-10 Appearance of the Printer with the Autocutter Installed (LTPF347 with ACUF324A)	9-10
9-11 Appearance of the Printer with the Autocutter Installed (LTPF347 with ACUF324B)	9-11

TABLES

Table		Page
3-1	General Specifications	3-1
3-2	General Motor Specifications	3-6
3-3	Excitation Sequence.....	3-8
3-4	Acceleration Steps.....	3-11
3-5	Motor Current Value	3-12
3-6	DST Blocks and Activated Heat Elements (LTPF247).....	3-16
3-7	Thermal Head Electrical Characteristics (LTPF247).....	3-17
3-8	DST Blocks and Activated Heat Elements (LTPF347).....	3-19
3-9	Thermal Head Electrical Characteristics (LTPF347).....	3-20
3-10	Head Resistance Ranks.....	3-21
3-11	Head Voltage.....	3-22
3-12	Temperature and Corresponding Thermistor Resistance.....	3-27
3-13	Absolute Maximum Ratings of the Paper Detector (at 25 °C).....	3-29
3-14	Paper Detector Input/Output Conditions	3-30
4-1	Connectors for External Circuit and Recommended Connectors for the Other FFC.....	4-1
4-2	Thermal Head Control Terminal Assignments (LTPF247).....	4-3
4-3	Thermal Head Control Terminal Assignments (LTPF347).....	4-4
4-4	Motor Control Terminal Assignments.....	4-5
9-1	Printer Mechanism and Corresponding Autocutter Unit.....	9-1

CHAPTER 1

PRECAUTIONS

Read through this manual to design and operate the printer properly. Pay special attention to the precautions noted in each section.

1.1 SAFETY PRECAUTIONS

Follow these precautions when designing a product using the printer, and include any necessary precautions and warning labels to ensure the safe operation of your product by users.

- **Preventing the thermal head from overheating**
When electricity is continuously supplied to the thermal head heat element by a CPU or other malfunction, the thermal head may overheat, causing smoke and fire. Follow the method described in **Section 3.6.7** to monitor the temperature of the thermal head to prevent overheating.
Turn the printer off immediately if any abnormal conditions occur.
- **Preventing the user from touching the thermal head and motor**
Warn the user not to touch the thermal head, its periphery or motor as they are hot during and immediately after printing. Failure to follow this instruction may lead to personal injury including burns.
Also, allow cooling by designing clearance between the head, motor and the outer case.
- **Precautions for sharp edges of the printer body**
Design the outer case so that the user cannot touch sharp edges of the printer body or the cutting surface of metal parts. Or, provide warnings concerning this matter.

1.2 DESIGN AND HANDLING PRECAUTIONS

To maintain the initial level of performance of the printer and to prevent future problems from occurring, observe the following precautions.

1.2.1 Design Precautions

Design precautions

- If too much energy is applied to the thermal head, it may overheat and become damaged. Always use the printer with the specified amount of energy.
- The current capacity of the thermal head is 13.6A. Design the circuit so that the average current does not exceed this value. (However, when the current capacity standard of harness is MAX.1A/pin, since the numbers of VP and GND pins are 8 pins and 9 pins, respectively, the current will be 8A and 9A each.
- Use C-MOS IC chips (74HC240 or equivalent) for interfacing the CLK, LATCH, DAT and DST signals of the thermal head.
- When turning the power on or off, always DISABLE (put in “high” state) the DST terminals.
- To prevent the thermal head from being damaged by static electricity:
 - Fix the printer to the Frame Ground (FG) by FG connection portions shown in **Figure 7-1** to **Figure 7-3**.
 - Connect the GND terminal (SG) to FG through an approximately 1 M Ω resistor.
- Keep the Vp power off while not printing in order to prevent the thermal head from being electrically corroded. In addition, design the printer so that the signal GND of the thermal head and the frame GND of the printer mechanism become the same electric potential.
- Wire resistance should be 50 m Ω or less and 30 cm or less (however the less the better) between the power supply and the Vp, and the GND terminals on the thermal head controller. Maintain a considerable distance from signal lines to reduce electrical interference.
- A surge voltage between Vp and GND should not exceed 28 V.
- As a noise countermeasure, connect the capacitor noted below between the Vdd and GND terminals near the thermal head control connector.
Capacitor: 0.1 μ F/15 V (aluminum electrolytic)
- Always detect the outputs of the platen position and paper detectors. Incorrect activation of the thermal head may reduce the life of the thermal head and the platen and damage them.
- The head activation time period may become longer according to the printing condition. If so, hold the phase of the motor and keep the pause time of the head activation for 0.1 msec or more. A continuous printing without a pause time may damage the thermal head.

- Always close the platen and feed the paper at 16 dots or more per line when printing is in a standby state. The elastic deformation of the platen roller rubber will be retreated.

Mechanism precautions

- Apply power in the following manner:
When turning the power ON: 1) Vdd (5 V) → 2) Vp (24 V)
At shut down: 1) Vp (24 V) → 2) Vdd (5 V)
- Cut surfaces of metallic parts may become discolored and rusted due to the operational environment. Consider these factors regarding appearance.
- Do not apply any stress to the thermal head connector when inserting and removing the PCB (Printed Circuit Board). After the PCB has been connected to the thermal head connector, design the outer case so that stress does not apply to the head connector. Stress may cause printing problems, resulting in damage to the thermal head.
- Always release the pressure of the thermal head when not using the printer for a long time (put the platen in platen open state). The platen pressured to the thermal head may become deformed.
- When closing the platen unit, the gear of the platen driving wheel may come in contact with the gear of the reduction wheel, making it impossible to install the platen. In this case, open the platen, and then close it again.
- Handle the platen unit with care because it is detachable. Flaws or dust on the platen roller and the platen driving wheel may reduce print quality. Be careful during installation because the plate may become deformed by stress.
- Do not pull out paper when the platen unit is closed.
- Stress to the platen frame while printing may reduce print quality.

Printing and paper feeding precautions

- Make sure that variation in the motor drive frequency does not lead to noise or a loss of paper feed force before making designs.
- Design the outer case to prevent the paper feed out from being caught in the platen.
- When or after printing or paper feed has been suspended, if data is input or printing restarts, paper feed may not be performed properly for several dot lines just after printing starts. This problem is more likely to occur when printing bit images.
- Do not open the platen unit while printing. The printer may be damaged.
- Do not use label paper, carbon paper, and thermal paper of more than 80 μ m.
- Do not perform back feed (backspin of the motor).

1.2.2 Handling Precautions

Incorrect handling may reduce the efficiency of the printer and cause damage. Handle the printer with the following precautions.

Also, include any necessary precautions so that users handle the printer with care.

- To prevent the heat elements, ICs, etc. from static electricity, discharge all static electricity before handling the printer.
Pay special attention to the thermal head control terminals when handling.
- Do not apply stress to the thermal head control terminals: Doing so may damage the connectors.
- If any paper other than that specified is used, high print quality and long life of the thermal head cannot be guaranteed.
- Using anything other than the specified paper may cause the following:
Poor printing quality
Abrasion of the thermal head
The thermal surface of the paper and the thermal head may stick together
Excessive noise
Fading print
Corroded thermal head
- Always print or feed with the specified paper inserted to protect the platen and thermal head.
- Do not hit or scratch the surface of the thermal head with any sharp or hard objects as it may damage the heat element.
- When the printer is not in use, place the thermal head in up position.
The head down (platen “close” state) and head up (platen “open” state) positions can be set with head up/down lever.
If the thermal head is remained in contact with the platen, the platen may become deformed.
- Never connect or disconnect cables with the power on. Always power off the printer first.
- When printing a black or checkered pattern at a high print rate in a low temperature or high humidity environment, the vapor from the paper during printing may cause condensation to form on the printer or may soil the paper.
If water condenses on the printer, keep the thermal head away from water drops as it may corrode the thermal head, and turn Vp off until it dries.
- The printer is not water-proof. Prevent contact with water and do not operate with wet hands as it may damage the printer or cause a short circuit or fire.
- Never use the printer in a dusty place, as it may damage the thermal head and cause paper feed trouble.

1.2.3 Precautions on Discarding

When discarding used printers, discard them according to the disposal regulations and rules of each respective district.

CHAPTER 2

FEATURES

The LTP F Series Line Thermal Printer Mechanism is a compact, super high-speed thermal line dot printing mechanism. It can be used with a measuring instrument and analyzer, a POS, a communication device, or a data terminal device.

The LTP F Series has the following features:

- **Super high speed printing** ^{*1}
A maximum print speed of 1760 dot lines per second (220 mm per second) is attainable for the LTP F series printer mechanism.
- **Easy loading of printing paper**
An easy loading of a printing paper with a detachable platen unit.
- **High resolution printing**
A high-density print head of 8 dots/mm produces clear and precise printing.
- **Long life** ^{*2}
The mechanism is maintenance-free device with a long life of 100 km print length or 100 million pulses.
- **Low noise**
Thermal line dot printing is used to guarantee low-noise printing.
- **Thermal head cleaning**
The removable platen unit enables the thermal head of the printer to be cleaned easily.
- **Anti-static electricity function**
Exposed metal parts of the printer can be connected to Frame Ground (FG) to minimize secondary radiation.

*1 Print speed differs depending on working conditions.

*2 Based on the life span judgment in the general specifications.

CHAPTER 3

SPECIFICATIONS

3.1 GENERAL SPECIFICATIONS

Table 3-1 General Specifications

Item	Specification				
	LTPF247		LTPF347		
Print method	Thermal dot line printing				
Dots per line	448 dots		640 dots		
Printable dots per line	432 dots		576 dots		
Simultaneously activatable dots per line	248 dots		352 dots		
Resolution	8 dots/mm				
Maximum print speed ^{*1}	220 mm/sec				
Print width	54 mm		72 mm		
Paper width	58 mm		80 mm		
Paper feed pitch	0.125 mm				
Head temperature detection	Via a thermistor				
Platen position detection	Via a mechanical switch				
Out-of-paper detection	Via a photo interrupter				
Operating voltage range					
Vp line	24V ± 10%				
Vdd line	5V ± 5%				
Current consumption used in driving the head (Vp) ^{*2}	Print ratio ^{*3}	Max.	Rated	Max.	Rated
	100%	10.4A	9.2A	14.8A	13.0A
	50%	5.2A	4.6A	7.4A	6.5A
	25%	2.6A	2.3A	3.7A	3.3A
	12.5%	1.3A	1.2A	1.9A	1.7A
Motor drive (Vp)	0.55 A max.				
Head Logic (Vdd)	0.1 A max.				
Operating temperature range (No condensation)	0°C to 50°C				
Storage temperature range (No condensation)	-20°C to 60°C				

^{*1} Print speed changes according to the processing speed of the controller and print pulse width.

^{*2} The current value indicates a momentary value obtained by calculation.

Calculation conditions

(1) "Max." indicates the values when the voltage is 26.4 V, the head resistance is 630.5 Ω, and fixed two-division printing is used.

(2) "Rated" indicates the values when the voltage is 24 V, the head resistance is 650 Ω, and fixed two-division printing is used.

^{*3} When printing equal to the print width is performed.

Table 3-1 General Specifications (Continued)

Item	Specification	
	LTPF247	LTPF347
Life span (at 25°C and rated energy) Activation pulse resistance Abrasion resistance	100 million pulses or more ^{*4} 100 km or more (excluding damage caused by dust and foreign materials)	
Paper feed force	0.98N (100 gf) or more	
Paper hold force	0.98N (100 gf) or more	
Dimensions (excluding the lever and convex part) (width × depth × height)	86.2 × 54 × 25.8 mm	110.2 × 54 × 25.8 mm
Mass	Approx. 150g	Approx. 175g
Specified thermal paper	TF50KS-E2C Normal thermal paper PD160R-N Medium proof paper HP220AB1 Medium proof paper	Nippon Paper Industries Oji Paper Co., Ltd. MITSUBISHI PAPER MILLS LIMITED

^{*4} Changing rate of average head resistance: ±15% or less

3.2 HEAT ELEMENT DIMENSIONS

3.2.1 Heat Element Dimensions for the LTPF247

The LTPF247 contains a thermal head with 448 heat elements (dot-size). The 432 dots (54 mm to the paper width 58 mm) is a printable area due to a relation with the paper width.

When transmitting print data, enter (NUL) data for data strings equivalent to 8 dots each on the right and left sides.

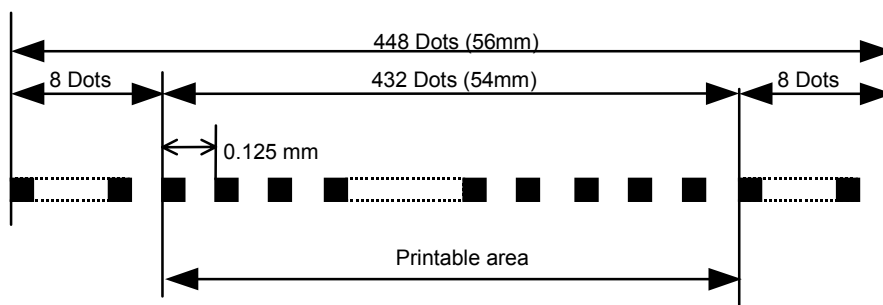

Figure 3-1 Heat Element Dimensions (LTPF247)

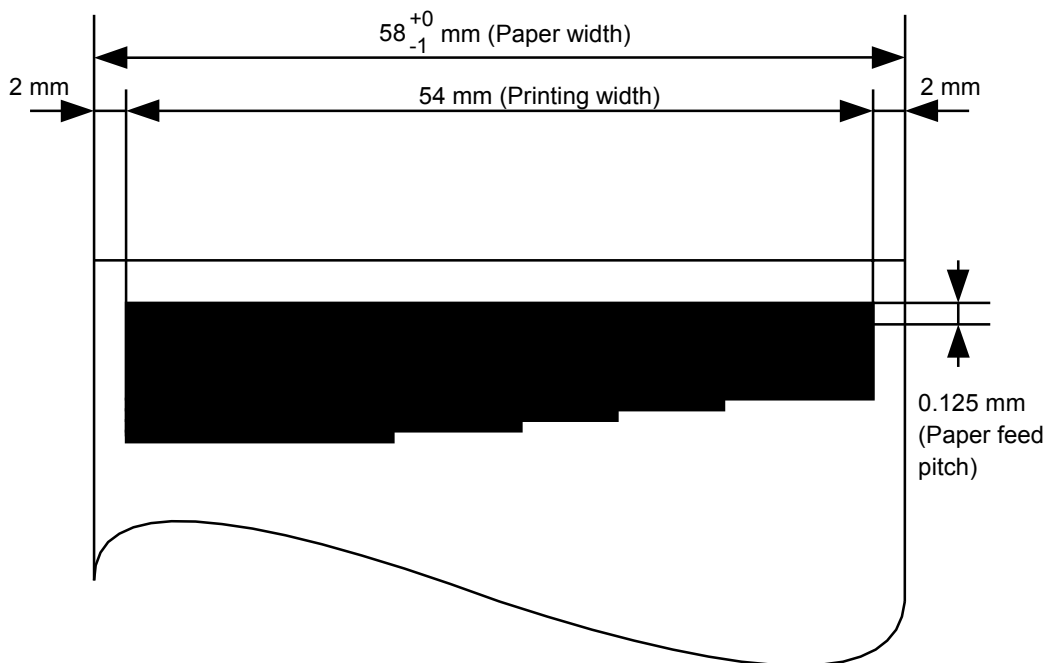

Figure 3-2 Print Area (LTPF247)

3.2.2 Heat Element Dimensions for the LTPF347

The LTPF347 contains a thermal head with 640 heat elements (dot-size). The 576 dots (72 mm to the paper width 80 mm) is a printable area due to a relation with the paper width. When transmitting print data, enter (NUL) data for the data string equivalent to 32 dots each in right and left sides.

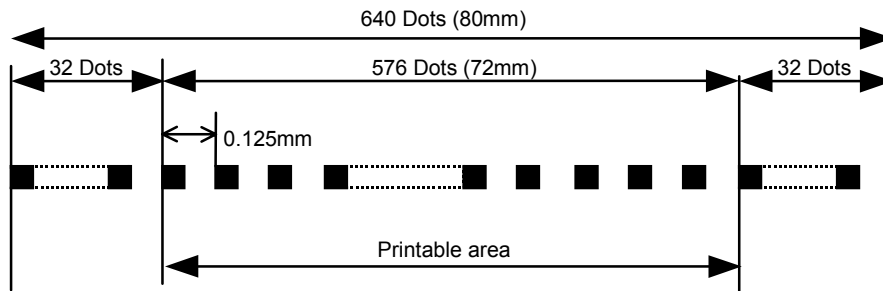

Figure 3-3 Heat Element Dimensions (LTPF347)

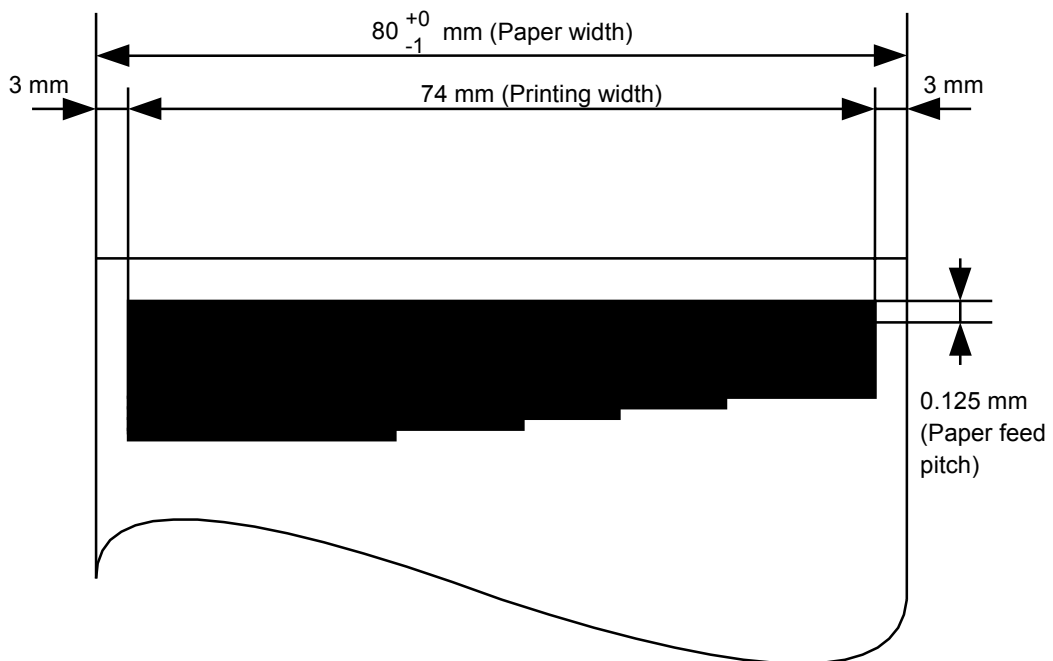

Figure 3-4 Print Area (LTPF347)

3.3 PAPER FEED CHARACTERISTICS

- The bipolar chopper driving method should be used for driving.
- Any type of design for the drive circuit other than the example described in **Section 3.4.1** may affect the standard function of the printer.
- Paper is fed in the forward direction when the motor shaft is rotating anticlockwise as seen from the motor gear side.
- The motor is driven by a 2-2 phase excitation method and feeds paper by 0.125 mm (equivalent to a single dot pitch) every one step of the motor drive signal.
- To prevent deterioration in print quality due to backlash of the paper feed system, the motor should be rotated 16 steps in the reverse direction, then 16 steps in the normal direction during initialization.
- During paper feed, the motor should be driven at 1760 pps through the motor acceleration control. As exceptions, when using the LTPF347 under 0°C to 10°C in temperature, drive it at 1200 pps or less. At dynamic division driving, do not use it more than 1200 pps.
- During printing, the motor drive frequency should be adjusted so that the head activation pulse width does not exceed the motor step time. (For details, see **CHAPTER 5 DRIVE METHOD**.)
- If the motor is continuously driven at less than 450 pps continuously, noise and/or paper sticking may occur.

3.4 STEP MOTOR CHARACTERISTICS

Table 3-2 General Motor Specifications

Item	Specification
Type	PM
Drive method	Bipolar chopper
Excitation	2-2 phase
Winding resistance per phase	16 Ω /phase \pm 10%
Rated voltage	V _p : 24 V \pm 10%
Set current	Approximately 275 mA/phase

3.4.1 Motor Drive Circuit

(1) Sample Drive Circuit

A sample drive circuit for the motor is shown in **Figure 3-5**.

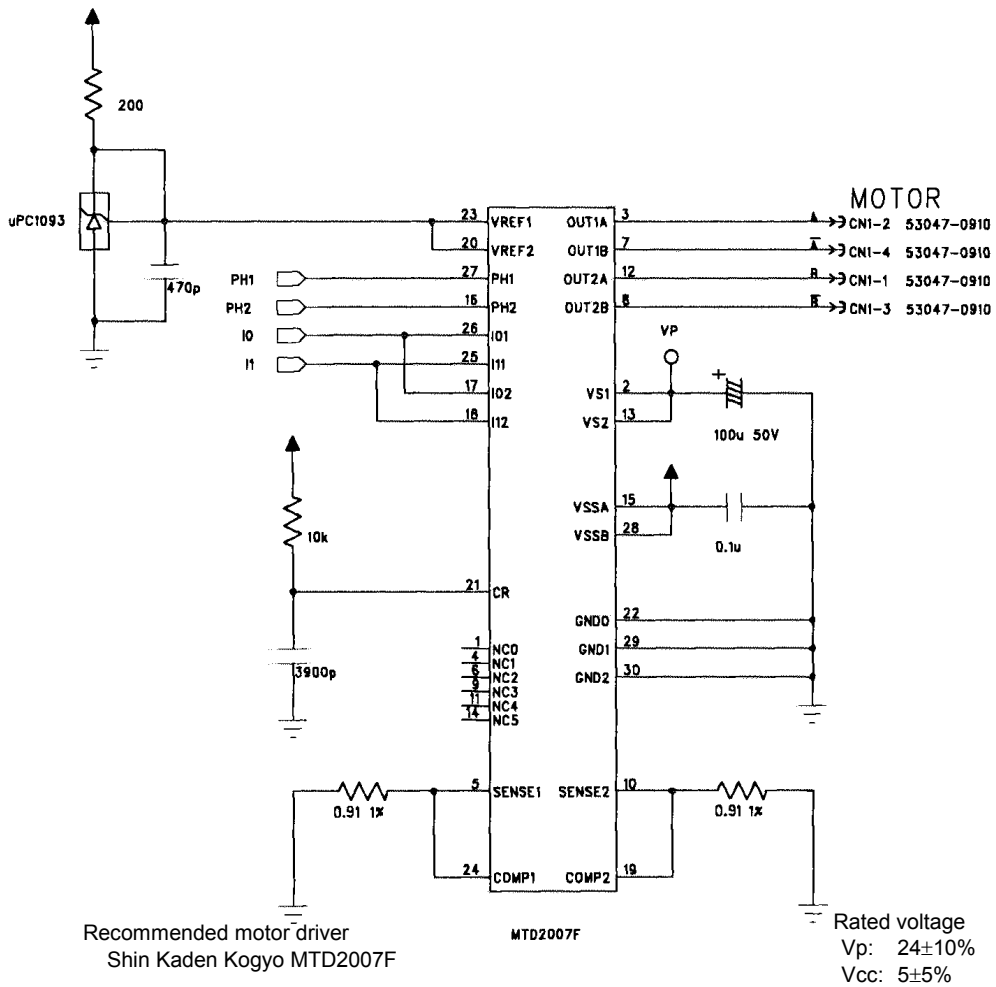

Figure 3-5 Sample Drive Circuit

(2) Excitation Sequence

When the voltage signals shown in **Figure 3-6** are input to the motor drive circuit shown in **Figure 3-5**, as shown in **Table 3-3**, the LTP F Series feeds the paper in the normal direction when the motor is excited in the order of step 1, step 2, step 3, step 4, step 1, step 2,

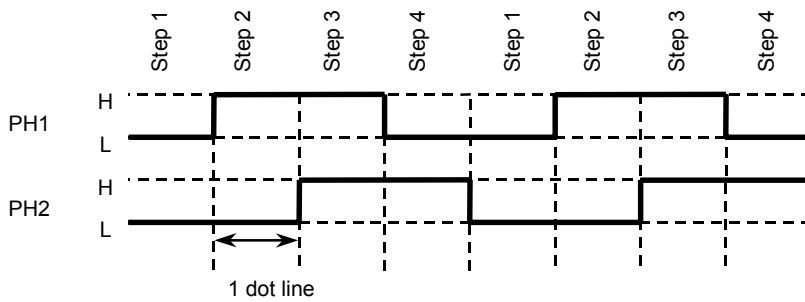

Figure 3-6 Input Voltage Signals for the Sample Drive Circuit

Table 3-3 Excitation Sequence

	Input Signal		Output Signal			
	PH1	PH2	B	A	\overline{B}	\overline{A}
Step 1	L	L	L	L	H	H
Step 2	H	L	L	H	H	L
Step 3	H	H	H	H	L	L
Step 4	L	H	H	L	L	H

3.4.2 Motor Timing

Refer to the time chart in **Figure 3-7** when designing the control circuit or software for starting and stopping the motor. Also, note the following precautions:

Precautions for Designing the Motor Control Circuit and Software

(1) Stop step

- To stop the motor, excite for 10 msec with the same phase as the last one in the printing step.

(2) Pause state

- In the pause state, do not excite the step motor by having I0, I1 go high so as to prevent the motor from heating. Even when the step motor is not excited, it maintains force to prevent the paper from sliding by a torque operation.

(3) Start step

- To restart the motor from the stop step, immediately shift the motor into the print sequence.
- To restart the motor from the pause (no excitation) state, shift the motor into the print step sequence after outputting the same phase as that of the stop step for the first step time of the acceleration step.

Input signals for a sample drive circuit are shown in **Figure 3-7**.

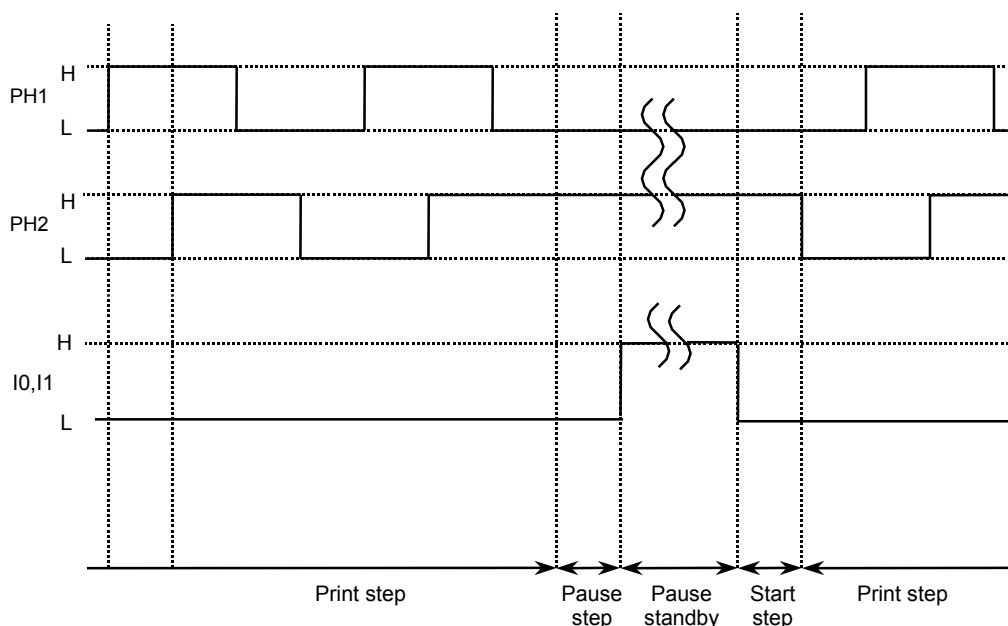

Figure 3-7 Motor Start/Stop Timing

3.4.3 Motor Driving Precautions

Acceleration Control

When driving the motor, acceleration control is needed to get start up in order to maintain the power force.

Drive the motor to the driving speed, according to acceleration steps shown in **Table 3-4**.

The method for accelerating the motor is as follows:

1. Output the start step time.
2. Output the first step for the first acceleration step time
3. Output the second step for the second acceleration step time
4. Output the nth step for the nth step acceleration time
5. After accelerating up to the motor driving speed, the motor is driven at constant speed.

The printer can print during acceleration.

The maximum printing speeds differ depending upon the drive method of the thermal head. Set the acceleration step as follows.

Accelerate the motor up to the step number 126 and motor driving frequency 1760 (PPS) for performing an acceleration control at two-division driving.

At dynamic division driving, or, when using the LTPF347 under 0°C to 10°C in temperature, change step number 59 into the motor driving frequency of 1200 (PPS) and step time 833 (μSEC), and then accelerate the motor up to the step number 59 and motor driving frequency 1200 (PPS).

Table 3-4 Acceleration Steps

Number of Steps	Speed (pps)	Step Time (μ sec)	Number of Steps	Speed (pps)	Step Time (μ sec)	Number of Steps	Speed (pps)	Step Time (μ sec)
Start	---	9027	43	1033	968	86	1455	687
1	111	9027	44	1045	957	87	1464	683
2	179	5579	45	1056	947	88	1472	679
3	232	4308	46	1068	936	89	1480	675
4	383	2614	47	1079	927	90	1489	672
5	400	2500	48	1090	917	91	1497	668
6	412	2426	49	1102	908	92	1505	664
7	440	2272	50	1113	899	93	1513	661
8	466	2144	51	1124	890	94	1521	657
9	491	2035	52	1134	882	95	1529	654
10	515	1941	53	1145	873	96	1537	651
11	538	1859	54	1156	865	97	1545	647
12	560	1786	55	1166	857	98	1553	644
13	581	1721	56	1177	850	99	1561	641
14	601	1663	57	1187	842	100	1569	637
15	621	1610	58	1197	835	101	1577	634
16	640	1561	59	1207	828	102	1584	631
17	659	1517	60	1217	821	103	1592	628
18	677	1477	61	1227	815	104	1600	625
19	695	1439	62	1237	808	105	1607	622
20	712	1404	63	1247	802	106	1615	619
21	729	1372	64	1257	796	107	1622	616
22	745	1342	65	1267	789	108	1630	614
23	761	1313	66	1276	784	109	1637	611
24	777	1287	67	1286	778	110	1645	608
25	793	1261	68	1295	772	111	1652	605
26	808	1238	69	1305	766	112	1660	603
27	823	1215	70	1314	761	113	1667	600
28	837	1194	71	1323	756	114	1674	597
29	852	1174	72	1333	750	115	1682	595
30	866	1155	73	1342	745	116	1689	592
31	880	1136	74	1351	740	117	1696	590
32	894	1119	75	1360	735	118	1703	587
33	907	1102	76	1369	731	119	1711	585
34	921	1086	77	1378	726	120	1718	582
35	934	1071	78	1387	721	121	1725	580
36	947	1056	79	1395	717	122	1732	577
37	959	1042	80	1404	712	123	1739	575
38	972	1029	81	1413	708	124	1746	573
39	985	1016	82	1421	704	125	1753	570
40	997	1003	83	1430	699	126	1760	568
41	1009	991	84	1438	695			
42	1021	979	85	1447	691			

Motor Current Control

The motor driving at a low speed may make noises during motor driving. Change the current value supplied to the motor so that the noise can be reduced.

The current value supplied can be switched by controlling I0 and I1 as follows.

Table 3-5 Motor Current Value

Motor reference set current I_m = Approx. 275 mA

I0	I1	Current Value
LOW	LOW	I_m (Approx. 275mA)
HIGH	LOW	$\frac{7}{10}I_m$
LOW	HIGH	$\frac{4}{10}I_m$
HIGH	HIGH	$\frac{0}{10}I_m$ 0mA

In each motor driving step, when the motor step time T_m (ms) is over 2.5 ms, drive the motor $\frac{4}{10}I_m$ up to the time of $T_m - 2.5$ (ms) and switch it into I_m (approx. 275mA).

Drive the motor at I_m (approx. 275 mA) if the motor step time T_m (ms) is 2.5 ms or less. It is not required to switch the current.

When the previous motor step time is 2.5 ms or less, drive the motor at I_m (approx. 275 mA). Do not switch the current even when the motor step time T_m (ms) is more than 2.5 ms.

A sample motor current control is shown in **Figure 3-8**.

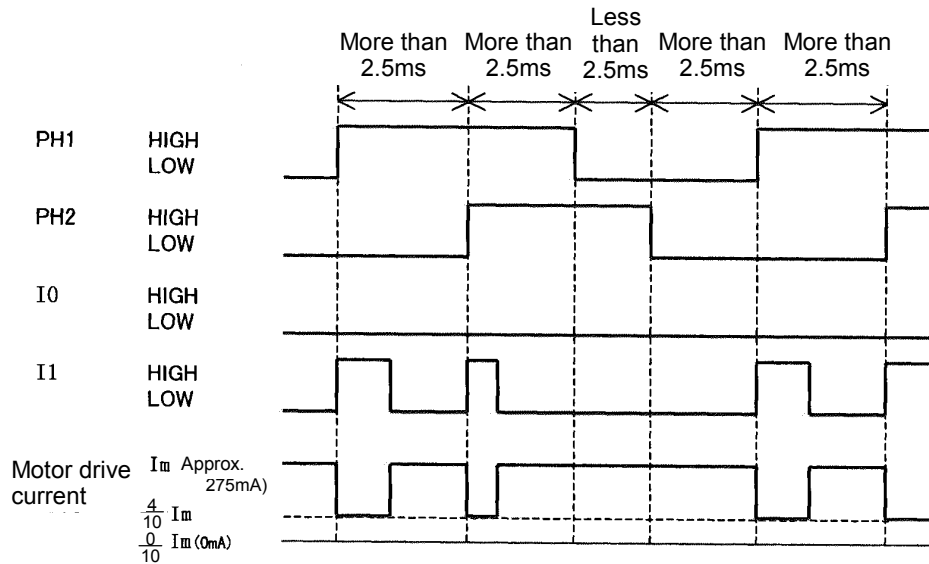

Figure 3-8 Sample of Motor Current Control

Drive the motor at I_m (approx. 275 mA) during the start-up step and the stop step. Do not switch the current.

Continuous driving

When the motor is driven for a long time or motor drive is often performed repeatedly, the motor heats up and may not be able to show necessary performance. To avoid it, when the motor was driven, set up the pause time of the same period of time as that the motor was driven. Furthermore, make one-time continuous driving 6 minutes (max.).

3.5 THERMAL HEAD

The thermal head consists of heat elements and a head driver which drives and controls the heat element.

Serial print data input from the DAT IN terminal is transferred to the shift register synchronously with the CLK signal, then stored in the latch register at the timing of the LATCH signal.

Input of the head print activation signal (DST1, 2) activates the heat elements in accordance with the print data stored in the latch register.

The LTP F series can be printed by dividing printing into blocks for every 128 dots.

The divided printing is effective for a high print ratio printing because the peak current can be cut down with the reduction of the average print speed.

When printing is performed using division into blocks of less than 128 dots, messy printing and/or abnormal sound may occur, and the printing quality may deteriorate remarkably. Check the number of dots in advance.

Also, when a pattern with a high print ratio is printed with less than 176 dots, a printing failure may occur due to the printing paper getting stuck depending on the ambient temperature, drive voltage and the thermal paper that is used.

When using a high-print ratio pattern, check the number of dots in advance.

3.5.1 Structure of the Thermal Head (LTPF247)

Figure 3-9 shows the thermal head block diagram for the LTPF247.

Table 3-7 shows the relationship between DST blocks and activated heat elements.

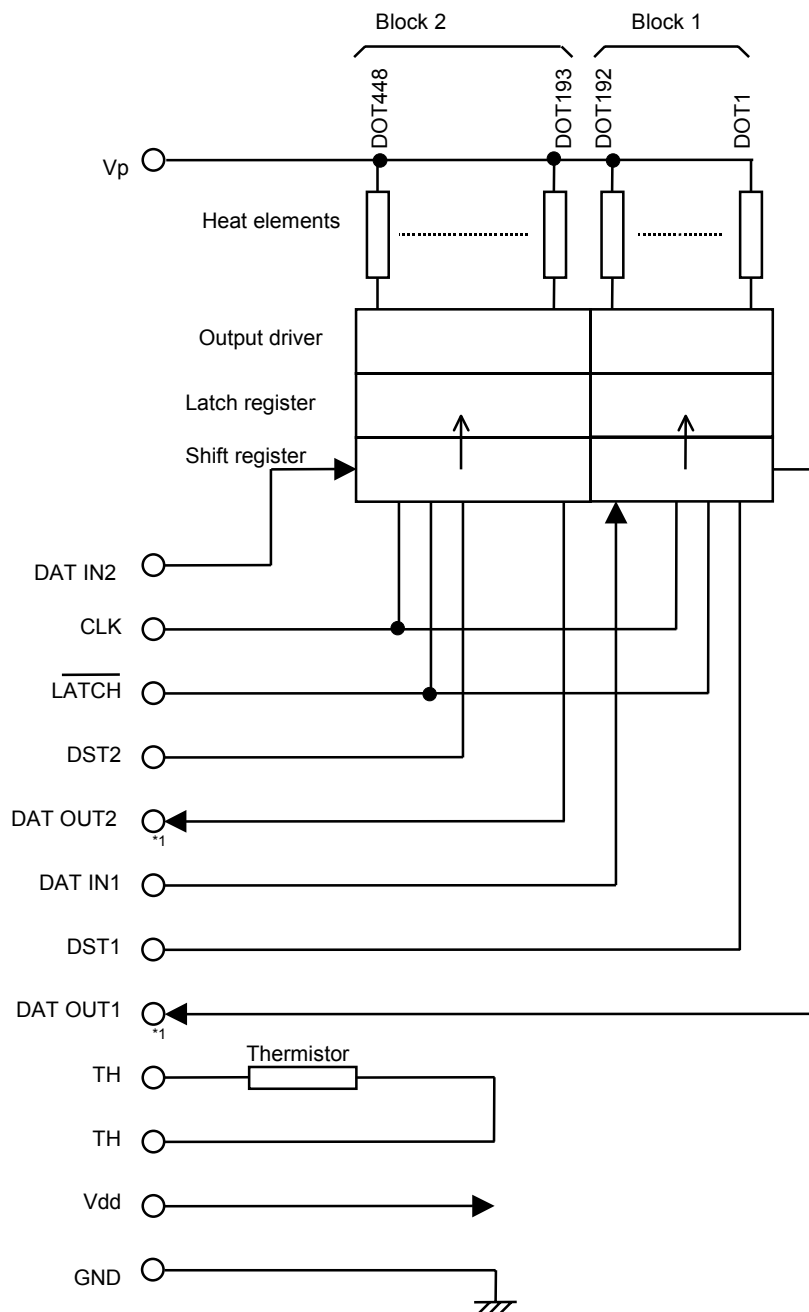

*1 N.C. if not using DAT OUT

Figure 3-9 Thermal Head Block Diagram (LTPF247)

Table 3-6 DST Blocks and Activated Heat Elements (LTPF247)

DST Number	Heat Element Number	Dots/DST
DST 1	1 to 192	192
DST 2	193 to 448	256

3.5.2 Printed Position of the Data (LTPF247)

192 data dots from No.1 to No.192 which are transferred through DAT IN1 terminal and 256 data dots from No.193 to No.448 are printed as shown in **Figure 3-10**.

For No.1 to No.8 of 192 data dots transferred from the DATA IN1 and No.441 to No.448 of 256 dots data transferred from the DATA IN2, set the NULL data.

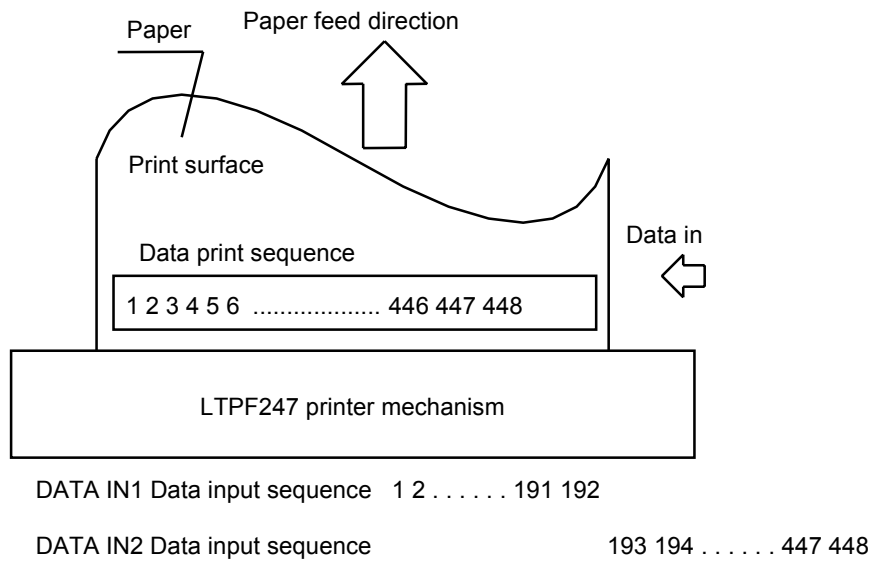

Figure 3-10 Printed Position of the Data (LTPF247)

3.5.3 Thermal Head Electrical Characteristics (LTPF247)

Table 3-7 Thermal Head Electrical Characteristics (LTPF247)

(Ta=25 ± 10°C)

Item	Symbol	Conditions	Rated value			Unit	
			MIN	TYP	MAX		
Head resistance	RH		630.5	650	669.5	Ω	
Head drive voltage	Vp		21.6	24.0	26.4	V	
Head drive current	Ip	At max. simultaneously activated dots number=248	–	9.2	10.4	A	
Logic block voltage	Vdd		4.75	5.00	5.25	V	
Logic block current	Idd	fCLK=8MHz, fDI=1/2fCLK	–	–	64	mA	
Input voltage	"High"	VIH	CLK,DAT,LATCH,DST	0.8×Vdd	–	Vdd	V
	"Low"	VIL	CLK,DAT,LATCH,DST	0	–	0.2×Vdd	V
DAT input current	"High"	IIH DAT	VIH = 5V	–	–	0.5	μA
	"Low"	IIL DAT	VIL = 0V	–	–	–0.5	μA
DST input current	"High"	IIH DST		–	–	120	μA
	"Low"	IIL DST		–	–	–2.0	μA
CLK input current	"High"	IIH CLK		–	–	2.0	μA
	"Low"	IIL CLK		–	–	–2.0	μA
LATCH input current	"High"	IIH LAT		–	–	2.0	μA
	"Low"	IIL LAT		–	–	–2.0	μA
DAT output current	"High"	VDOH	OPEN state, Vdd =4.5V	4.45	–	–	μA
	"Low"	VDOL		–	–	0.05	μA
CLK frequency	f CLK		–	–	4	MHz	
CLK pulse width	tw CLK	See Timing Chart	35	–	–	ns	
DAT setup-time	tsetup DI	See Timing Chart	30	–	–	ns	
DAT hold time	thold DI	See Timing Chart	10	–	–	ns	
DAT out delay time	td DO	See Timing Chart	–	–	120	ns	
LATCH pulse width	tw LAT	See Timing Chart	100	–	–	ns	
LATCH setup time	tsetup LAT	See Timing Chart	200	–	–	ns	
LATCH hold time	thold LAT	See Timing Chart	50	–	–	ns	
DST setup time	tsetup DST	See Timing Chart	300	–	–	ns	
Output delay time	tDo	See Timing Chart	–	–	10	ns	

3.5.4 Structure of the Thermal Head (LTPF347)

Figure 3-11 shows the thermal head block diagram for the LTPF347.

Table 3-8 shows the relationship between DST blocks and activated heat elements.

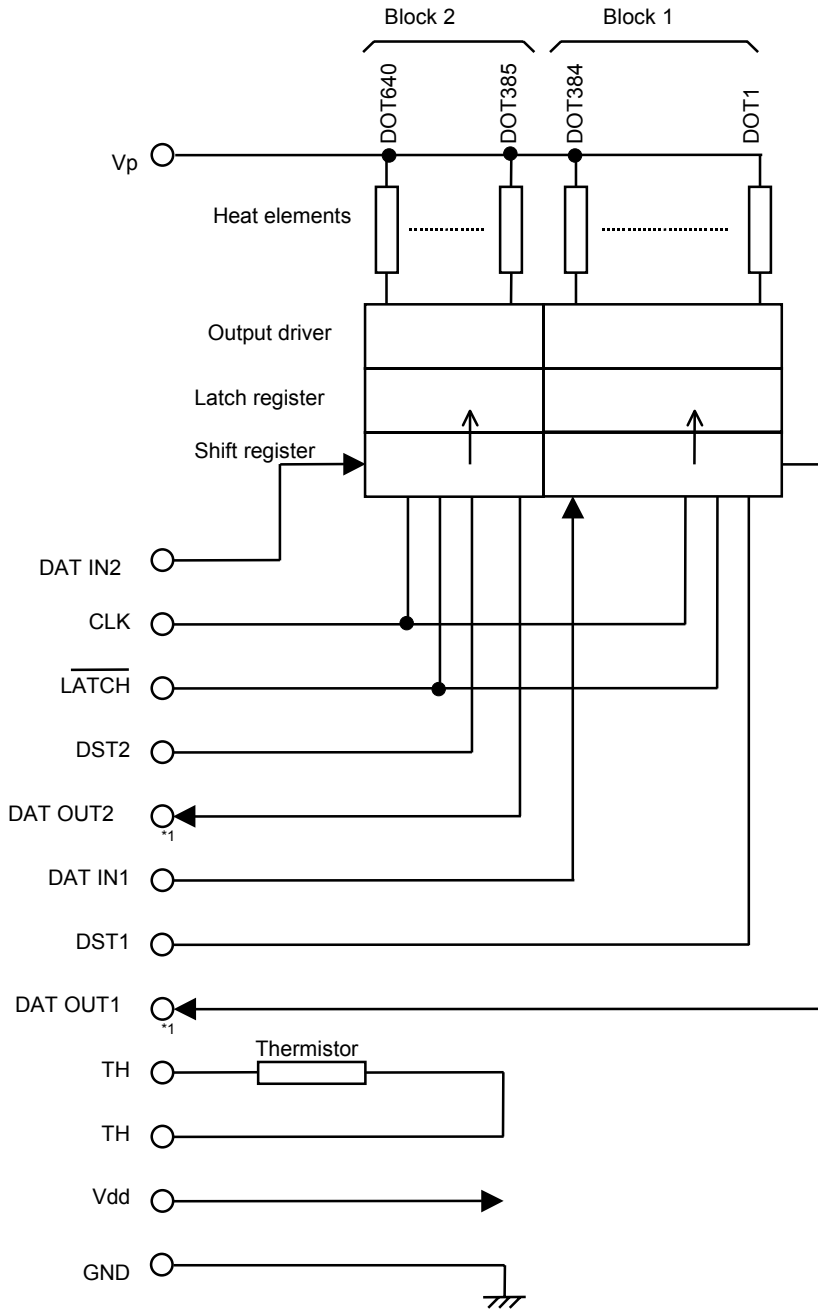

*1 N.C. if not using DAT OUT

Figure 3-11 Thermal Head Block Diagram (LTPF347)

Table 3-8 DST Blocks and Activated Heat Elements (LTPF347)

DST Number	Heat Element Number	Dots/DST
DST1	1 to 384	384
DST2	385 to 640	256

3.5.5 Printed Position of the Data (LTPF347)

384 data dots from No.1 to No.384 which are transferred through DAT IN1 terminal and 256 data dots from No.385 to No.640 are printed as shown in **Figure 3-12**.

For No.1 to No.32 of 384 data dots transferred from the DATA IN1 and No.609 to No.640 of 256 data dots transferred from the DATA IN2, set the NULL data.

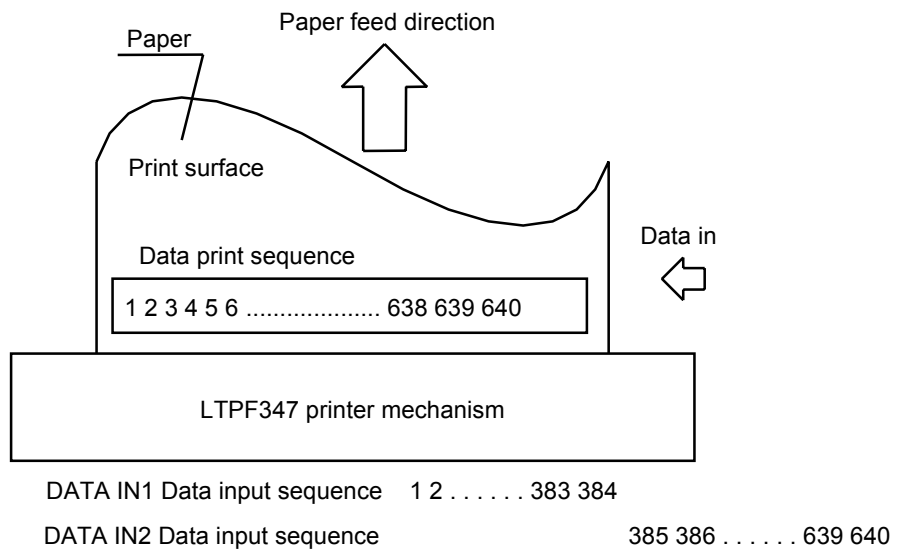

Figure 3-12 Printed Position of the Data (LTPF347)

3.5.6 Thermal Head Electrical Characteristics (LTPF347)

Table 3-9 Thermal Head Electrical Characteristics (LTPF347)

(Ta=25 ± 10°C)

Item	Symbol	Conditions	Rated value			Unit	
			MIN	TYP	MAX		
Head resistance	RH		630.5	650	669.5	Ω	
Head drive voltage	Vp		21.6	24.0	26.4	V	
Head drive current	Ip	At max. simultaneously activated dots number=352	–	13.0	14.8	A	
Logic block voltage	Vdd		4.75	5.00	5.25	V	
Logic block current	Idd	FCLK=8MHz, fDI=1/2fclk	–	–	64	mA	
Input voltage	"High"	VIH	CLK,DAT,LATCH,DST	0.8×Vdd	–	Vdd	V
	"Low"	VIL	CLK,DAT,LATCH,DST	0	–	0.2×Vdd	V
DAT input current	"High"	IIH DAT	VIH = 5V	–	–	0.5	μA
	"Low"	IIL DAT	VIL = 0V	–	–	–0.5	μA
DST input current	"High"	IIH DST		–	–	120	μA
	"Low"	IIL DST		–	–	–2.0	μA
CLK input current	"High"	IIH CLK		–	–	2.0	μA
	"Low"	IIL CLK		–	–	–2.0	μA
LATCH input current	"High"	IIH LAT		–	–	2.0	μA
	"Low"	IIL LAT		–	–	–2.0	μA
DAT output current	"High"	VDOH	OPEN state, Vdd =4.5V	4.45	–	–	μA
	"Low"	VDOL		–	–	0.05	μA
CLK frequency	f CLK		–	–	8	MHz	
CLK pulse width	tw CLK	See Timing Chart	35	–	–	ns	
DAT setup-time	tsetup DI	See Timing Chart	30	–	–	ns	
DAT hold time	thold DI	See Timing Chart	10	–	–	ns	
DAT out delay time	td DO	See Timing Chart	–	–	120	ns	
LATCH pulse width	tw LAT	See Timing Chart	100	–	–	ns	
LATCH setup-time	tsetup LAT	See Timing Chart	200	–	–	ns	
LATCH hold time	thold LAT	See Timing Chart	50	–	–	ns	
DST setup time	tsetup DST	See Timing Chart	300	–	–	ns	
Output delay time	tDo	See Timing Chart	–	–	5	ns	

3.5.7 Timing Chart

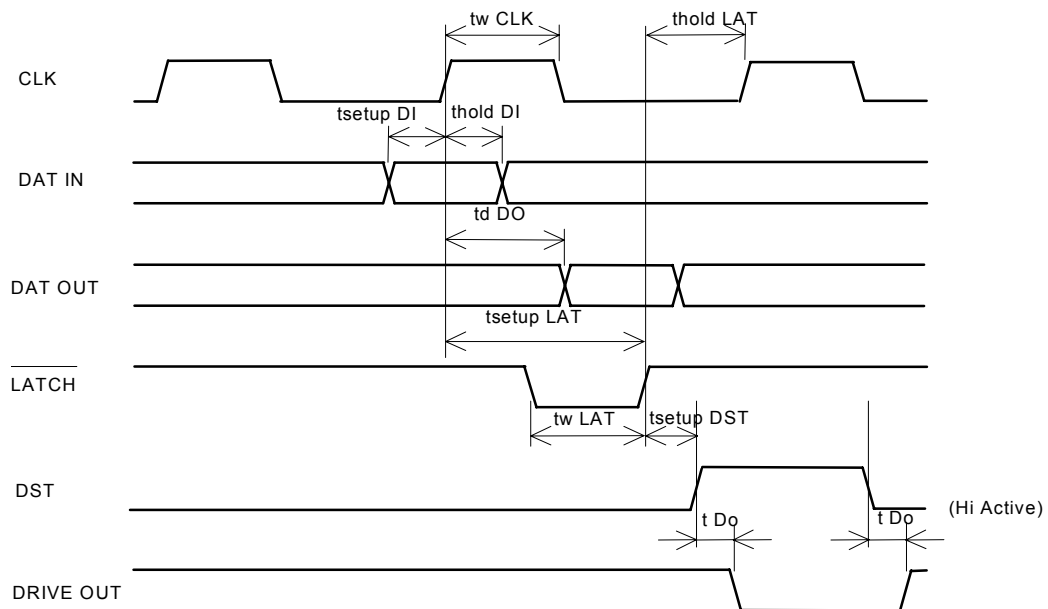

Figure 3-13 Timing Chart

3.5.8 Head Resistance

The LTP F Series head resistance is as shown in **Table 3-10**.

Table 3-10 Head Resistance Ranks

Head Resistance
630.5 to 669.5 Ω

3.5.9 Head Voltage

The printer has a built-in head driver IC. **Table 3-11** shows the head voltage.

Table 3-11 Head Voltage

Item		Voltage Range
Head drive voltage	V_P	21.6 to 26.4 V
Head logic voltage	V_{dd}	4.75 to 5.25 V

3.5.10 Peak Current

Since the peak current (maximum current) may reach the values calculated using equation (1) when the thermal head is driven, make sure that the allowable current for the cable material and the voltage drop on the cables are well within the specified range.

Equation (1):

$$I_P = \frac{N \times V_P}{RH}$$

- I_P : Peak current (A)
- N: Number of dots that are driven at the same time
- V_P : Head drive voltage (V)
- RH: Head resistance (Ω)

3.6 CONTROLLING THE HEAD ACTIVATION (DST) PULSE WIDTH

3.6.1 Calculation of the Head Activation Pulse Width

To execute high quality printing using the printer, the value that is calculated using the following equation (2) must be adjusted according to the printer installation environment. Calculate each value used according to the steps in **Sections 3.6.2 to 3.6.5** and control so that the pulse width with the t (msec) value obtained by substituting each value into the equation (2).

Equation (2):

$$t = E \times \frac{R}{V^2} \times C \times D$$

t: Heat pulse width (ms)

V: Applied voltage (V)

E: Standard applied energy (mj)

Refer to **Section 3.6.2.**

R: Head resistance (Ω)

Refer to **Section 3.6.3.**

C: Head activation pulse term coefficient

Refer to **Section 3.6.4.**

D: Heat Storage coefficient

Refer to **Section 3.6.5.**

Printing using too high of voltage or too long of pulse width may shorten the life of the thermal head.

3.6.2 Calculation of the Applied Energy

The applied energy should be according to the temperature of the thermal head and operational environment.

The thermal head has a built-in thermistor. Measure the temperature using the thermistor resistance.

The applied energy also differs according to the thermal paper used.

The applied energy is calculated by substituting a temperature coefficient and thermal paper coefficient into the equation (3).

Equation (3):

$$E = E_0 \times P \times (1 - T_c (T_x - 25))$$

E: Print energy (mj)

E₀: Standard applied energy 0.210 (mj)

T_x: Detected temperature using the thermistor (°C) ¹

P: Thermal paper coefficient

TF50KS-E2C (Nippon Paper Industries): 0.9

PD160R-N (New Oji Paper Co., Ltd): 1.0

HP220AB1 (MITSUBISHI PAPER MILLS LIMITED): 1.0

T_c: Temperature coefficient: 0.0076

^{*1} The thermistor resistance value at T_x (°C). Refer to **Section 3.6.6.**

3.6.3 Adjustment of the Head Resistance

Adjustment of the head resistance is according to equation (4). Due to wiring resistance there is a drop in voltage.

Equation (4):

$$R = \frac{(R_H + R_i + (R_c + r_c) \times N)^2}{R_H}$$

R_H: Head resistance, R_H=650 Ω

R_i: Wiring resistance in the thermal head (Ω), R_i=25Ω

R_c: Common terminal wiring resistance in the thermal head

LTPF247 R_c=0.14 (Ω)

LTPF347 R_c=0.165 (Ω)

r_c: Wiring resistance between V_p and GND (Ω)*¹

N: Number of dots driven at the same time

*¹ This resistance value is equal to the resistance of the wire used between the thermal head control connector and the power supply including the resistance of switching circuit of relay, etc.

3.6.4 Head Activation Pulse Term Coefficient

According to equation (5), calculate the compensation coefficient of the head activation pulse term (equal motor drive frequency) to get the constant printing density even when changing the printing speed such as start up acceleration control.

Equation (5):

$$C = 2.7 - \frac{3.59}{C_x + W}$$

C_x: Speed correction coefficient 1.57

W: Head activation cycle of one dot line (ms)

* When the motor drive frequency is 666 pps or less:
W = 666 pps (fixed)

3.6.5 Heat Storage Coefficient

A difference between an actual rise in temperature of the thermal head due to the head activation and the detected temperature by the thermistor occurs in the high speed printing.

Therefore, a correction of the activation pulse through the simulation of a rise in thermal head temperature is needed.

A correction may not be needed when the print ratio is low. Set "1" as the heat storage coefficient at this time.

The heat storage coefficient is calculated with the manner as follows:

- (1) Prepare the heat storage software counters for each block to simulate the heat storage.

- (a) Heat storage due to the head activation

The heat storage counter counts up in each print cycle as follows.

$$D = \frac{64 \times N}{B}$$

When $D > 50$, $D = 50$

$$T' = T + D$$

T: Heat storage counter value

N: Number of the activated dots

B: Total dot number of each block

- (b) Radiation due to time

The heat storage counter value is multiplied by the radiation coefficient in each 1 msec.

$$T' = T \times K$$

K: Radiation coefficient 0.997

- (2) Calculate the heat storage coefficient with the following equation, using the heat storage counter.

Equation (6):

$$D = 1 - \frac{T}{74981}$$

3.6.6 Thermistor Resistance

The resistance of the thermistor at the operating temperature T_x (°C) is determined using the following equation (7).

Equation (7):

$$R_x = R_{25} \times \text{EXP} \left\{ B \times \left(\frac{1}{273 + T_x} - \frac{1}{298} \right) \right\}$$

- R_x : Resistance at operating temperature T_x (°C)
- R_{25} : $30 \text{ k}\Omega \pm 5\%$ (25°C)
- B : $3950 \text{ K} \pm 2\%$
- T_x : Operating temperature (°C)
- EXP (A) : The Ath power of natural logarithm e (2.71828)

[Rating]

Operating temperature range: -40°C to $+125^\circ\text{C}$

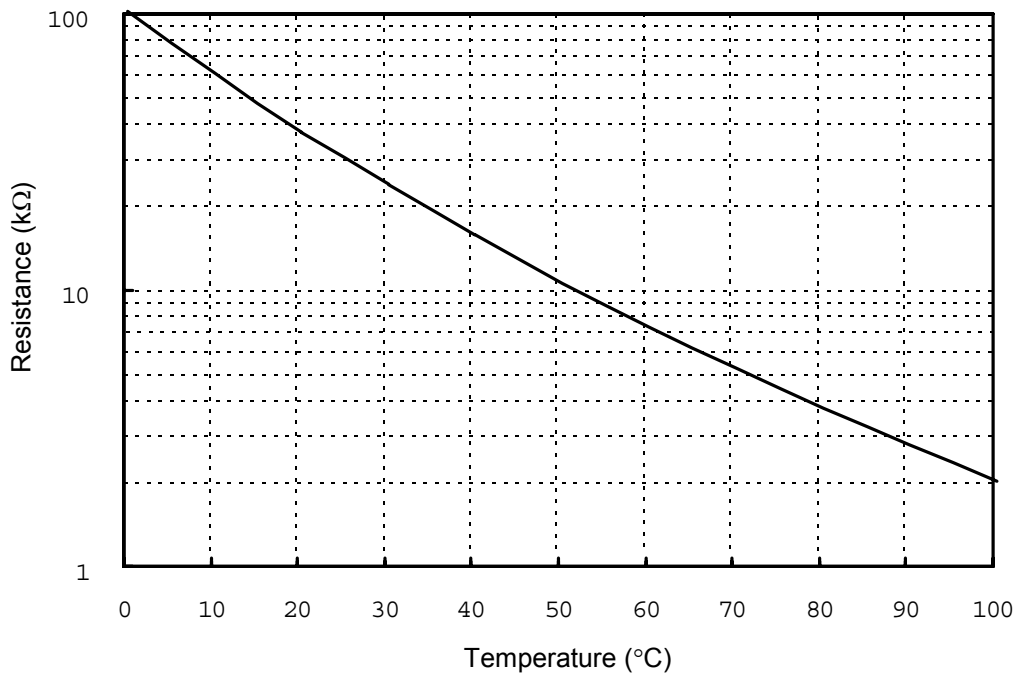

Figure 3-14 Thermistor Resistance vs. Temperature

Table 3-12 Temperature and Corresponding Thermistor Resistance

Temperature (°C)	Thermistor Resistance (kΩ)
0	100.99
5	77.85
10	60.57
15	47.53
20	37.61
25	30.00
30	24.11
35	19.51
40	15.89
45	13.03
50	10.75
55	8.92
60	7.45
65	6.25
70	5.27
75	4.47
80	3.80
85	3.25
90	2.79
95	2.41
100	2.09

3.6.7 Detecting Abnormal Temperatures of the Thermal Head

To protect the thermal head and to ensure personal safety, abnormal thermal head temperatures must be detected by both hardware and software as follows:

- Detecting abnormal temperatures by software

Design software that will deactivate the heat elements if the thermal head thermistor (TH) detects a temperature of 80°C or more (thermistor resistance $R_{TH} \leq 3.80 \text{ k}\Omega$), and reactivate the heat elements when a temperature of 60°C or lower ($R_{TH} \geq 7.45 \text{ k}\Omega$) is detected. If the thermal head continues to be activated at a higher temperature than 80°C, the life of the thermal head may be shortened significantly.

- Detecting abnormal temperatures by hardware

If the control unit (CPU) malfunctions, the software for detecting abnormal temperatures may not function properly, resulting in overheating of the thermal head. The overheating of the thermal head may cause damage to the thermal head or cause skin burns.

Always use hardware in conjunction with software for detecting abnormal temperatures to ensure personal safety (this may not prevent damage to the thermal head).

Using a window comparator circuit or similar detector, design hardware that detects the following abnormal conditions:

- (a) Overheating of the thermal head (approximately 100°C or higher ($R_{TH} \leq 2.09 \text{ k}\Omega$))
- (b) Faulty thermistor connection (the thermistor may be open or short-circuited).

If (a) and (b) detected, immediately deactivate the heat elements. Reactivate the heat elements after they have returned to normal.

3.7 PAPER DETECTOR

The printer has a built-in paper detector (reflection type photo-interrupter) to detect whether paper is present or not.

An external circuit should be designed so that it detects the output from the paper detector and does not activate the thermal head when there is no paper. Doing not so may cause damage to the thermal head or platen roller or shorten the life of the thermal head significantly.

3.7.1 General Specifications

Table 3-13 Absolute Maximum Ratings of the Paper Detector (at 25°C)

Item		Symbol	Maximum Rating
LED (input)	Forward current	I_F	50 mA
	Reverse voltage	V_R	5 V
	Allowable current	P	75 mW
Phototransistor (output)	Collector-to-emitter voltage	V_{CEO}	20 V
	Emitter-to-collector voltage	V_{ECO}	5 V
	Collector current	I_C	20 mA
	Collector loss	P_C	70 mW
Operating temperature		T_{opr}	-20 to +80°C
Storage temperature		T_{stg}	-30 to +100°C

Table 3-14 Paper Detector Input/Output Conditions

Item		Symbol	Conditions	Min.	Std.	Max.
LED (input)	Forward voltage	V_F	$I_F=10\text{ mA}$	1.0 V	1.2 V	1.6 V
	Reverse current	I_R	$V_R=5\text{ V}$	—	—	10 μA
Photo-transistor (output)	Dark current	I_{CEO}	$I_F=0\text{ mA}, V_{CE}=10\text{ V}$	—	—	200 nA
Transfer characteristics	Photoelectric current	I_C	$I_F=10\text{ mA}, V_{CE}=5\text{ V}$	150 μA	—	600 μA
	Leak current	I_{LEAK}	$I_F=10\text{ mA}, V_{CE}=5\text{ V}$	—	—	1 μA
	Collector saturation voltage	$V_{CE(sat)}$	$I_F=10\text{ mA}, I_C=5\text{ }\mu\text{A}$	—	—	0.5V
	Response time (at rise)	t_r	$I_C=1\text{ mA}, V_{CC}=5\text{ V}$	—	5 μs	—
	Response time (at fall)	t_f	$R_L=100\Omega$	—	5 μs	—

3.7.2 Sample External Circuit

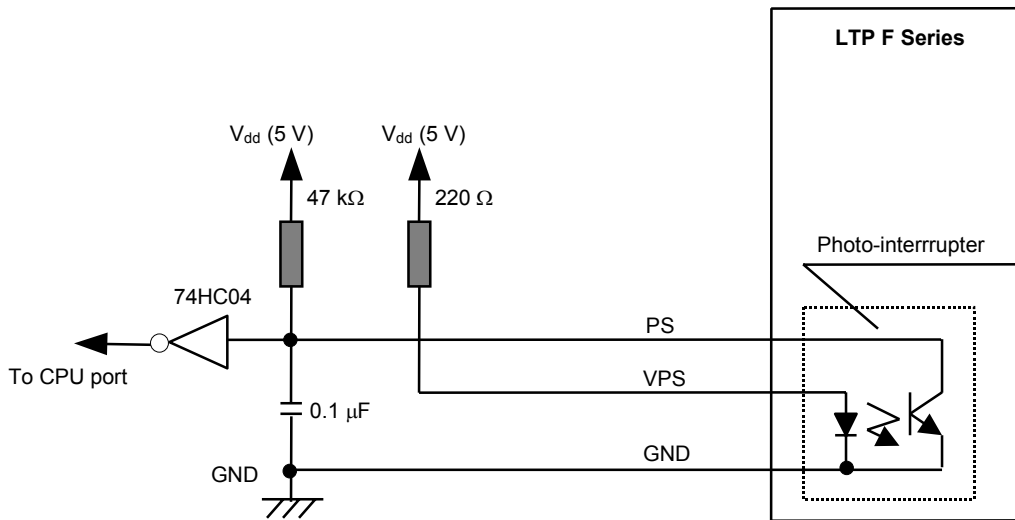

*The PS signal is high when there is no paper.

Figure 3-15 Sample External Circuit of the Paper Detector

3.8 PLATEN POSITION DETECTOR

The printer has a built-in platen position detector for detecting whether the platen unit is opened or closed. This detector is a mechanical switch which is designed to be in a CLOSED state when the platen unit is closed and to be in an OPENED state when it is opened.

The combination of the platen position detector with the paper detector in Chapter 3.7 will make it possible to detect the position of the platen.

The external circuit should be designed so that it detects output from the platen position detector in order to detect the platen OPENED state, or, so that it detect output from the paper detector in Chapter 3.7, so as not to activate the thermal head in the absence of paper. Otherwise, the thermal head may be damaged or the life of the head may be shortened significantly. Activate the thermal head when the platen unit is CLOSED by detecting the output from the platen position detection, and in the paper presence state by detecting the output from the paper detector.

3.8.1 General Specifications

Maximum rating: 7 V DC, 1 mA
Contact resistance: 70 m Ω maximum

3.8.2 Sample External Circuit

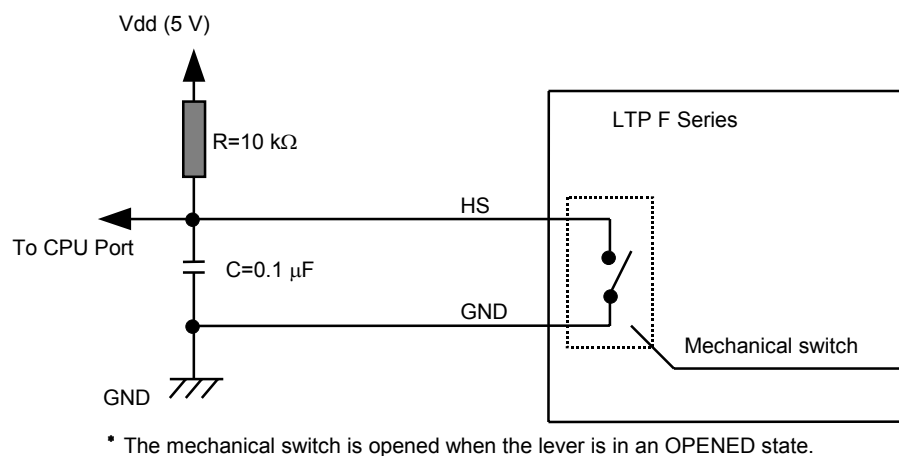

Figure 3-16 Sample External Circuit of the Platen Position Detector

Note that there is a time lag between the time when the thermal head stays in a completely upwards or downwards position and when the lever position detector starts to operate.

Always use the capacitor shown in **Figure 3-16** to prevent the switch from malfunctioning due to chattering.

CHAPTER 4
CONNECTING TERMINALS

Use the recommended connectors listed in **Table 4-1** to connect the printer firmly to the external circuits.

Table 4-1 Connectors for External Circuit and Recommended Connectors for the Other FFC

No.	Function and Model Number	Number of Pins	Recommended Connectors (External Circuit)
1	Thermal head control connector (JAE:IL-FPC-28CLIP)	28	Core number: 28, Conductor type: 0.1×0.8, Strip length: 4.0, Conductor pitch: P1.25 *
2	Motor connector and Detector connector (MOLEX INC: 51021-0900)	9	MOLEX INC: 53047-0910 (straight type) 53048-0910 (right angle type) 51047-0910 (trunk type)

* For installing reinforcing plates, adjust the length of the reinforcing plate to conform with the layout in the mechanism and the steel case.
Design the length between FFC terminals so that loads cannot be made after connecting to the PCB. This is because the head unit can be slid back and forth by opening and closing the platen.

4.1 THERMAL HEAD CONTROL TERMINALS

Figure 4-1 shows the terminal configuration of the thermal head control connector.



Figure 4-1 Thermal Head Control Terminals

Table 4-2 Thermal Head Control Terminal Assignments (LTPF247)

Terminal Number	Signal Name	Input/Output	Function
1	Vp	—	Head drive power
2	Vp	—	Head drive power
3	Vp	—	Head drive power
4	Vp	—	Head drive power
5	DAT OUT1	Output	Print data output
6	DAT IN1	Input	Print data input
7	GND	—	GND
8	GND	—	GND
9	GND	—	GND
10	GND	—	GND
11	GND	—	GND
12	DST1	Input	Head print activation instruction signal
13	CLK	Input	Print data transfer synchronize signal
14	LATCH	Input	Print data latch (memory)
15	Vdd	—	Logic power supply (5V)
16	TH	Output	Thermister
17	TH	Output	Thermister
18	DST2	Input	Head print activation instruction signal
19	GND	—	GND
20	GND	—	GND
21	GND	—	GND
22	GND	—	GND
23	DAT OUT2	Output	Print data output
24	DAT IN2	Input	Print data input
25	Vp	—	Head drive power
26	Vp	—	Head drive power
27	Vp	—	Head drive power
28	Vp	—	Head drive power

Table 4-3 Thermal Head Control Terminal Assignments (LTPF347)

Terminal Number	Signal Name	Input/Output	Function
1	Vp	—	Head drive power
2	Vp	—	Head drive power
3	Vp	—	Head drive power
4	Vp	—	Head drive power
5	DAT OUT1	Output	Print data output
6	DAT IN1	Input	Print data input
7	GND	—	GND
8	GND	—	GND
9	GND	—	GND
10	GND	—	GND
11	GND	—	GND
12	DST1	Input	Head print activation instruction signal
13	CLK	Input	Print data transfer synchronize signal
14	LATCH	Input	Print data latch (memory)
15	Vdd	—	Logic power supply (5V)
16	TH	Output	Thermister
17	TH	Output	Thermister
18	DST2	Input	Head print activation
19	GND	—	GND
20	GND	—	GND
21	GND	—	GND
22	GND	—	GND
23	DAT OUT2	Output	Print data output
24	DAT IN2	Input	Print data input
25	Vp	—	Head drive power
26	Vp	—	Head drive power
27	Vp	—	Head drive power
28	Vp	—	Head drive power

4.2 MOTOR CONTROL TERMINALS

Figure 4-2 shows the terminal configuration for motor control and detector connection, and Table 4-4 shows their terminal assignments.

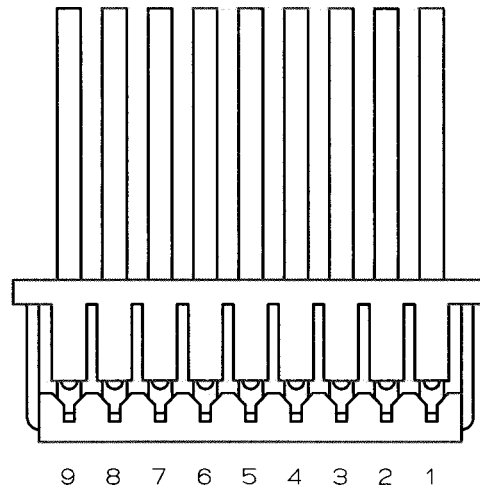

Figure 4-2 Terminals on the Motor Connector

Table 4-4 Motor Control Terminal Assignments

Terminal Number	Signal Name	Function
1	B	Motor drive signal
2	A	Motor drive signal
3	\bar{B}	Motor drive signal
4	\bar{A}	Motor drive signal
5	Vps	LED anode (Power supply side)
6	PS	Photo transistor collector (Output side)
7	$\overline{\text{GND}}$	Paper detector GND
8	$\overline{\text{GND}}$	Platen position detector GND
9	HS	Platen position detector output

* Terminal numbers 8 and 9 can be reversed because the platen position detector is a mechanical switch.

CHAPTER 5

DRIVE METHOD

Drive the motor and the thermal head at the same time for printing. **Figure 5-1** is a timing chart for driving using two divisions. **Figure 5-1** is an example of acceleration control of the motor, data transfer to the head and two-divisions of the head.

Timing chart of **Figure 5-1** is explained in order thereafter.

- A: Pause state
Transfer the data which are printed in the first dot line to the SHIFT REGISTER in the DST1 side of the thermal head.
- B: Start step output
Output the same phase to the motor as that having been output just before the motor stopped. The step time is the first acceleration step term.
- C: First step
 - (1) Latches the print data transferred in step A in the LATCH REGISTER and activates the thermal head with the DST1.
 - (2) Transfers the remaining data in the DST2 side to the SHIFT REGISTER in the DST2 side of the thermal head.
 - (3) When the activation of DST1 is completed, the print data transferred by (2) is latched in the LATCH REGISTER of the head and activation to the thermal head is started with DST2.
 - (4) The print data printed in the DST1 side of the 2nd dot line print data is transferred to the SHIFT REGISTER in the DST1 side of the thermal head.
 - (5) After the 1st step time of the motor is finished, the motor goes on to the next step.
- D: Second step
 - (1) Latches the print data transferred in step (C) to the LATCH REGISTER of the thermal head and starts activation with the DST1.
 - (2) Transfers the remaining data in the DST2 side to the SHIFT REGISTER of the thermal head in the DST2 side.
 - (3) Latches the print data transferred in (2) to the LATCH REGISTER and starts activation with the DST2 after activation of the DST1 is completed.
 - (4) After the second step time is completed, the motor goes on to next step.

Repeat the steps in the same way. Transfer the data which will be printed in the next step to the thermal head while starting the activation of the thermal head.
 The data transfer time and head activation time may be longer than the motor step time according to the type of the thermal paper, printing data and operational environment.
 In this case, hold the motor step until completion of printing.
 Keep 0.1 msec or more for the pause time after head activation.

The print data in the First step can be transferred while outputting the Start step (B). However, the print data is transferred before outputting the Start step in **Figure 5-1**.

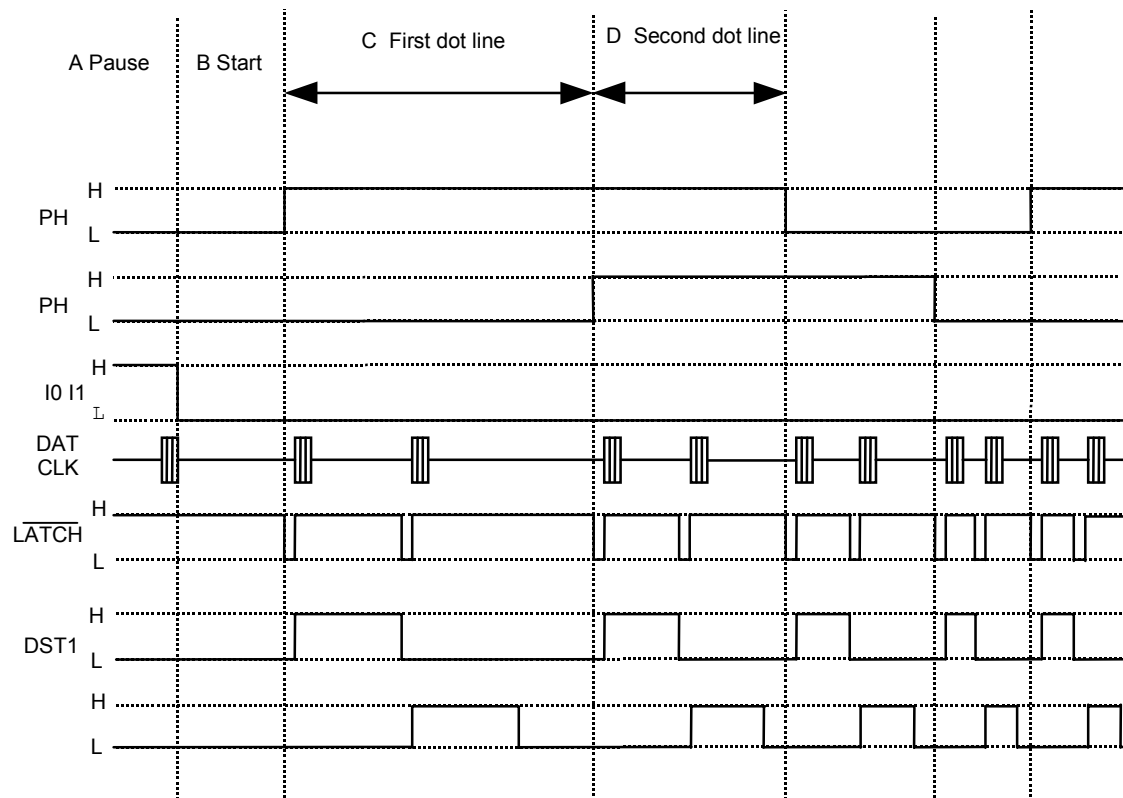

Figure 5-1 Timing Chart for Driving Using Two Divisions

CHAPTER 6

HOUSING DESIGN GUIDE

6.1 SECURING THE PRINTER

6.1.1 Printer Mounting Dimensions

As shown in **Figure 6-1**, secure the printer at four mounting holes: a, b, c and d. The indents #1 and #2 are for positioning.

6.1.2 Recommended Screws

Recommended mounting screws are as follows:

- ① JIS B1111 M2.6 and M3 Cross-Recessed Head Machine screw
- ② Small P Tight 2.6 screw for resinated material

6.1.3 Precautions for Securing the Printer

Pay attention to the following when securing the printer. Failure to follow these instructions may cause deterioration of print quality, paper skew, paper jam, noise or damage.

- Prevent excessive force or torsion when securing the printer.
- Mount the printer on the flat mounting face and use the printer in a place where vibration does not occur. A rubber vibration isolator is also effective to prevent vibration.
- Connect both U shaped gutters c to FG (Frame Ground) on the circuit board with metal screws to prevent damage to the thermal head due to static electricity.
- Make equipotential between FG and signal ground by connecting both with an approximately 1 M Ω resistor.
- Do not damage the lead wires when securing the printer with screws.

6.2 LAYOUT OF PRINTER AND PAPER

The LTP F Series can be laid out as shown in **Figure 6-2** according to the loading direction of the paper.

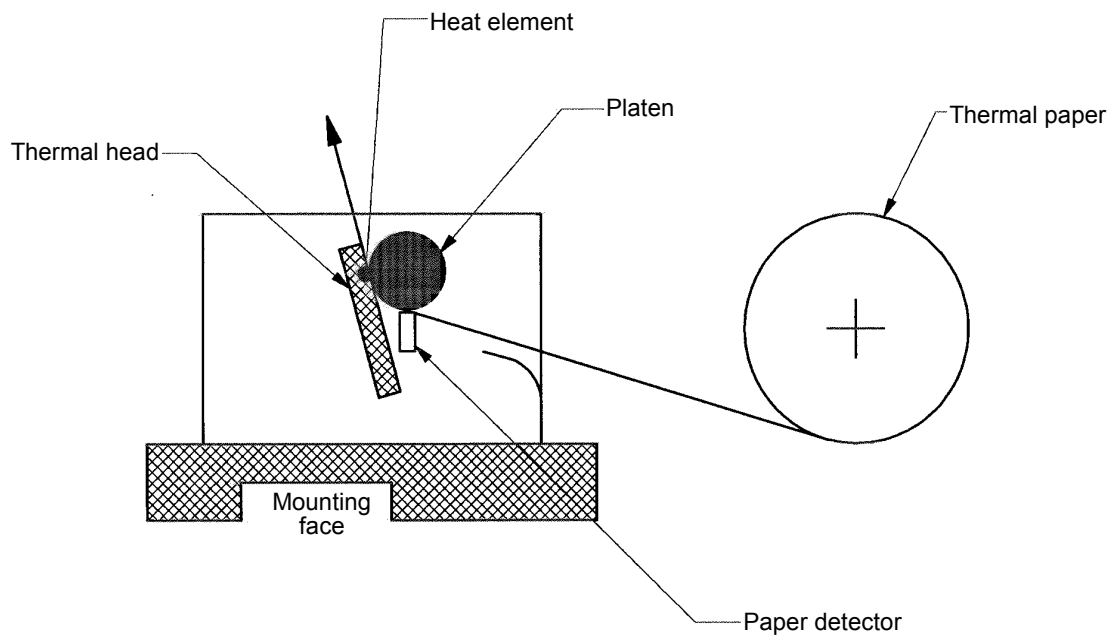

The distance between the paper detector and the heat element is approximately 8 mm.

Figure 6-2 Layout of Printer and Paper

6.3 WHERE TO MOUNT THE PAPER HOLDER

When determining the layout of paper holder, note the following:

- When you use a paper roll, set the holder so that the paper is straight in relation with the paper inlet without any horizontal shifting, and the center axis of the paper roll is parallel with the printer.
- Paper supply load to the printer should be 0.49N (50gf).

6.4 WHERE TO MOUNT THE PLATEN UNIT

The dimensions of alignment for the mechanical unit and the platen unit are shown in **Figure 6-3** for a situation when the platen unit has been mounted to the outer case, and the unit has been opened and closed.

Design the mounting position of the revolving point on the platen unit for the outer case so that it is contained within the dimension tolerance shown in **Figure 6-3**.

In some construction cases of the outer case, the mechanical unit and platen unit may be able to be matched even if the mounting position etc. of the platen unit is outside the dimension tolerance shown in **Figure 6-3**. Make sure that excessive stress is not applied to the outer case and/or platen unit in said situation.

An incorrect mounting position of the revolving point on the platen unit may cause an alignment failure of the mechanical unit and/or the platen unit, leading to printing problems. The installation of an exclusive autocoder may cause bad cutting or paper jams.

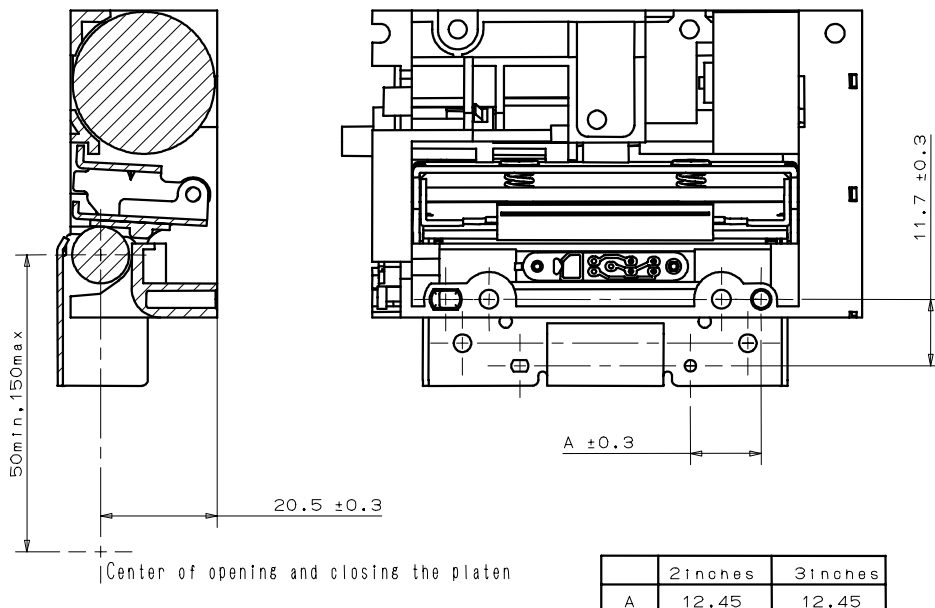

Figure 6-3 The Platen Unit Mounting Position

6.5 WHERE TO MOUNT THE PLATEN RELEASE KNOB

The platen release knob fitted to the outer case can be installed by using the outer shape of the release lever and three holes. **CHAPTER 7** shows the appearance and the positions of the holes.

Do not apply a force of 29.4 N (3 kgf) or more to the release lever. Doing so may cause deformation and malfunction of the lever.

6.6 WHERE TO MOUNT THE PAPER CUTTER

Design the layout of the autocutter so that it does not interfere with the paper feed. The position for feeding out paper is shown in **CHAPTER 7 APPEARANCE AND DIMENSIONS**.

- If the distance between the edge of the thermal head and the edge of the fed paper is too small, the paper may be caught in the platen. Please take this into account when designing the outer case.
- Use a cutter with a sharp edge so that paper is cut with the paper hold force or less.

CHAPTER 7

APPEARANCE AND DIMENSIONS

Figure 7-1 shows the appearance and the external dimensions of the LTPF247.

Figure 7-2 shows the appearance and the external dimensions of the Platen Unit for the LTPF247.

Figure 7-3 shows the appearance and the external dimensions of the LTPF347.

Figure 7-4 shows the appearance and the external dimensions of the Platen Unit for the LTPF347.

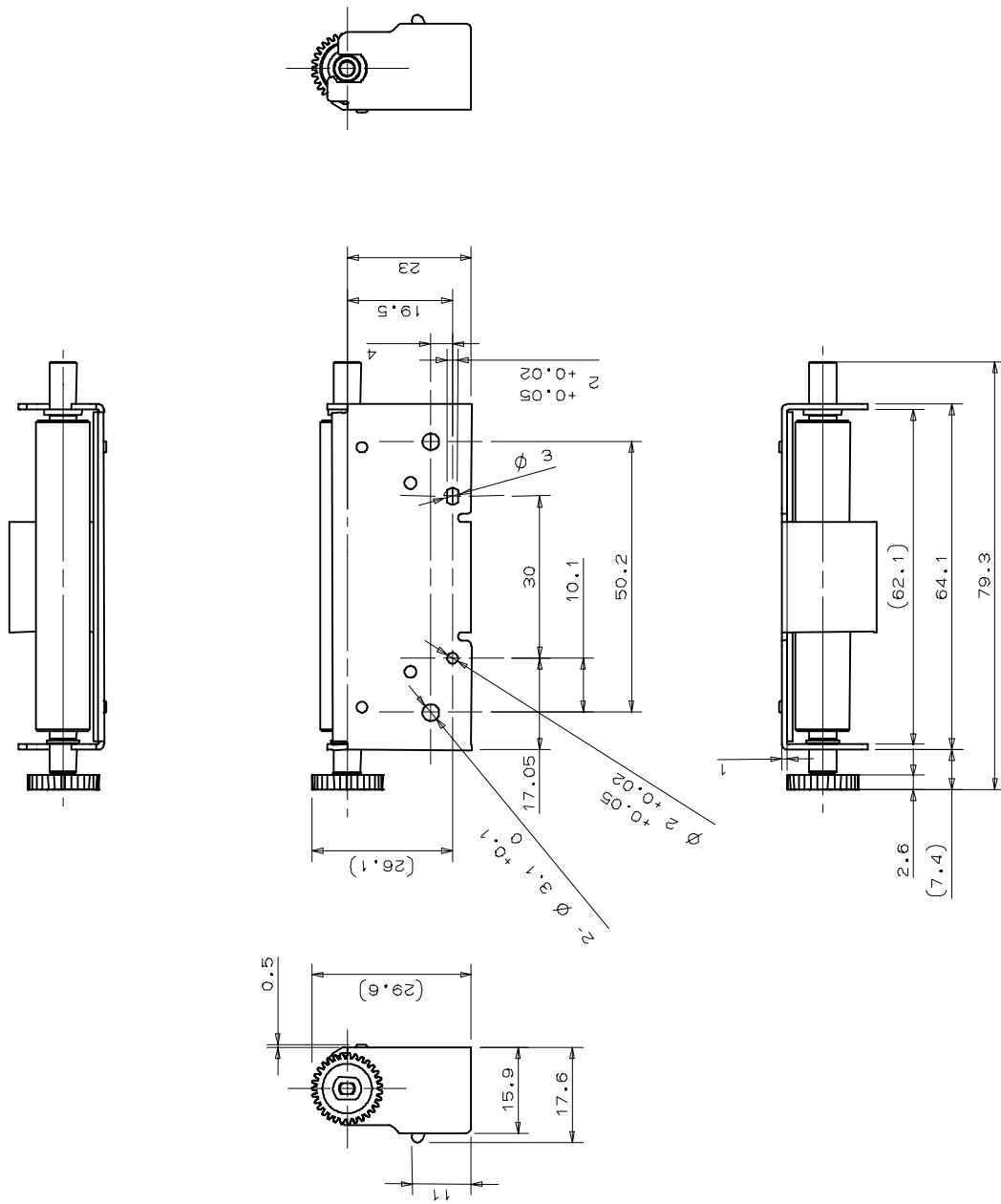

Unit: mm
 General tolerance: ± 0.2

Figure 7-2 Appearance and Dimensions of the Platen Unit (LTPF247)

CHAPTER 8

LOADING/UNLOADING PAPER AND HEAD CLEANING

8.1 LOADING/UNLOADING PAPER PRECAUTIONS

(1) Loading paper

- Turn over the release lever to the direction of the arrow in the **Figure 8-1**.

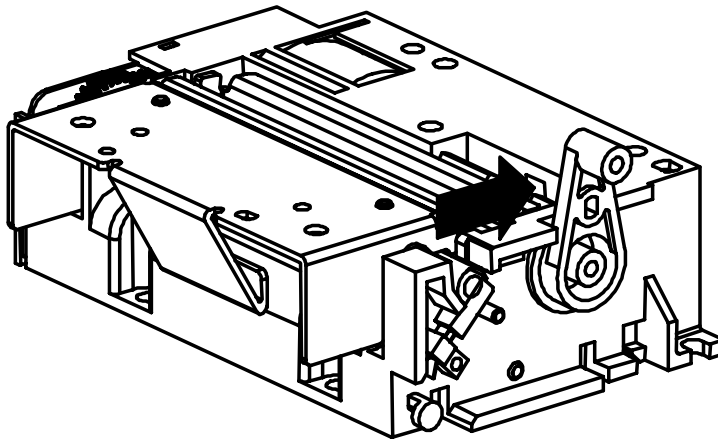

Figure 8-1 Loading Paper (1)

- Pull up the platen after making sure that the platen is released from the release lever. (Open state)

- Set the paper straight into the paper insert position until 5 cm or more of the paper edge is projected from the upper surface of the mechanism. (See **Figure 8-2.**) Close the platen after making sure that the paper is set straight. (Close state)

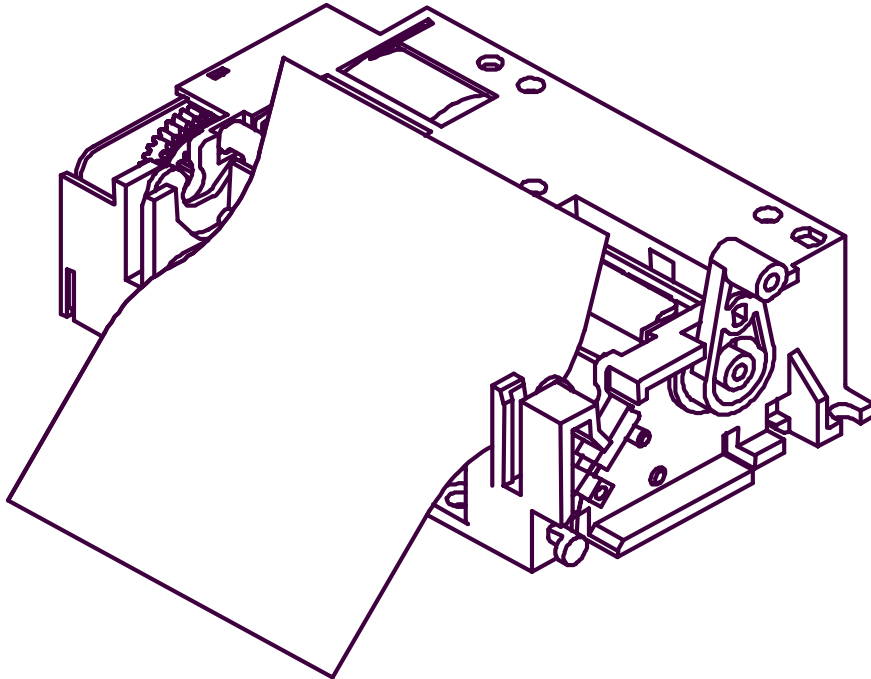

Figure 8-2 Loading Paper (2)

- When the platen is closed, the gear A and the gear B come together (See **Figure 8-3**) and the platen may stop. In this case, pull up the platen by the release lever, and then close the platen again.

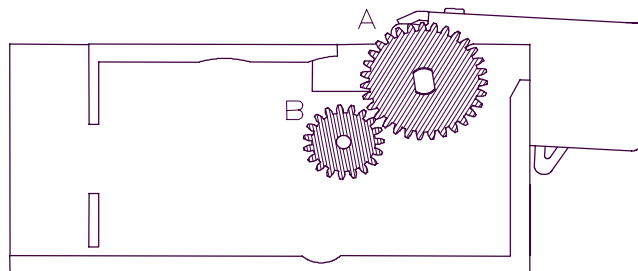

Figure 8-3 Loading Paper (3)

- When the paper slants after being inserted, either feed paper until it straightens out or reset the paper.

(2) Unloading paper

- Unload paper in the same manner for loading paper.

(3) Cleaning a paper jam

- Unload the paper, following manner for unloading the paper.

8.2 HEAD CLEANING PRECAUTIONS AND PROCEDURE

8.2.1 Head Cleaning Precautions

- (1) Do not clean the head directly after printing because the thermal head unit and its periphery are hot.
- (2) Do not use sandpaper, cutter, etc. when cleaning. They will damage the heat elements.

8.2.2 Head Cleaning Procedure

- (1) Turn over the lever to the direction of the arrow in the **Figure 8-4**. Pull up the platen after making sure that the platen is released from the lever. (Open state)
- (2) Clean the heat elements with a cotton swab immersed in ethyl alcohol or isopropyl alcohol.
- (3) After the alcohol has completely dried, close the platen. (Close state)

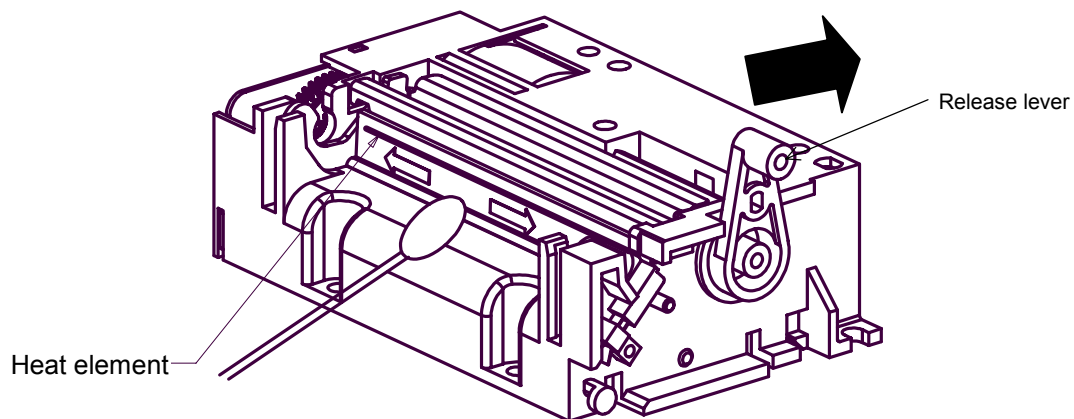

Figure 8-4 Head Cleaning Procedure

CHAPTER 9
PERIPHERALS

9.1 AUTOCUTTER UNIT

The ACU F Series autocutter unit can be installed on this printer as shown in **Table 9-1**.

The ACU F Series paper cutter unit is a sliding type autocutter.

Please refer to the “**ACU F SERIES AUTOCUTTER UNIT TECHNICAL REFERENCE**” for the specifications and drive method.

Table 9-1 Printer Mechanism and Corresponding Autocutter Unit

LTP F Series	ACU F Series
LTPF247	ACUF224A, ACUF224B
LTPF347	ACUF324A, ACUF324B

9.1.1 Installation Method

(1) Installing the autocutter unit

Movable unit

Place the movable blade unit on the mechanism as shown in **Figure 9-1**.
Recommended screws: JIS 1188 pan head machine screw (small round type) M3×6

Be careful not to damage the thermal head during installation.

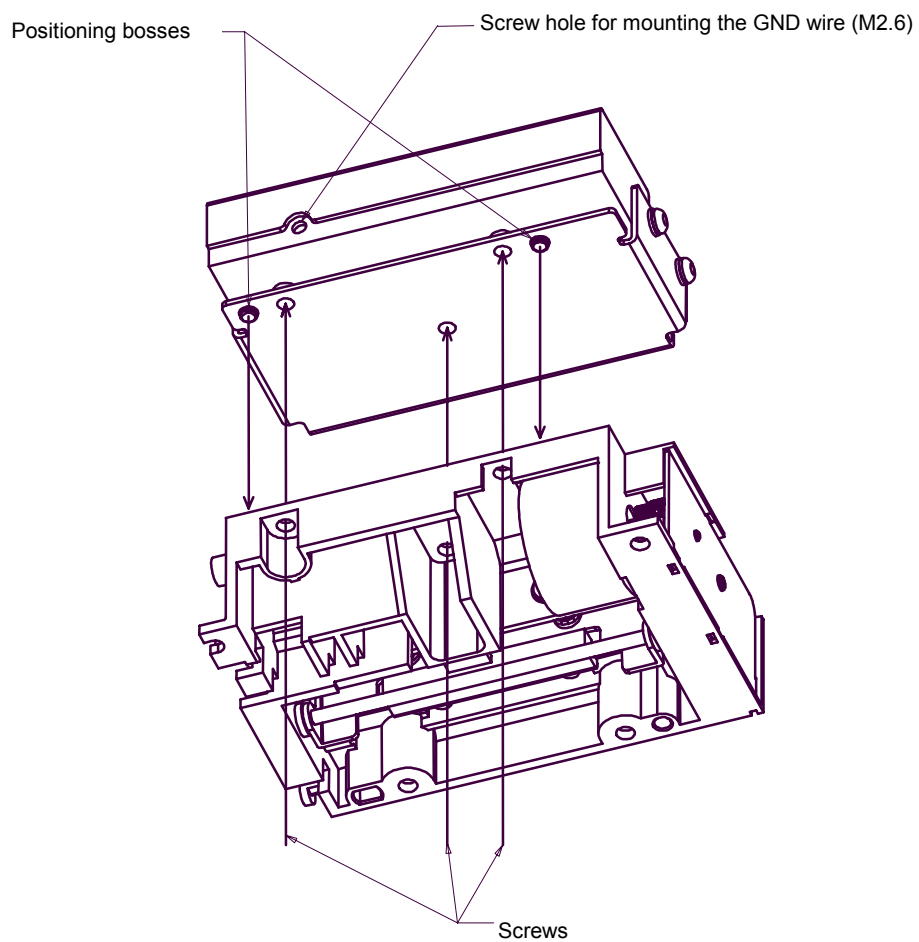

Figure 9-1 Installing the Autocutter Unit (Movable blade unit)

Fixing Blade Unit

- (1) Remove the protection tape that is attached to the fixing blade unit as shown in **Figure 9-2**.

Handle with care the fixing blade edge after removing the protection tape.

- (2) Mount the fixing blade unit to the autocutter unit with 2 screws.
Recommended screws: JIS 1188 pan head machine screw (small round type) M2×4.

Be careful not to damage the platen during installation.

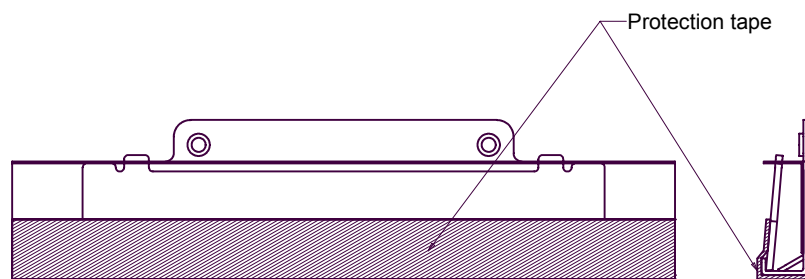

Figure 9-2 Fixing Blade Unit

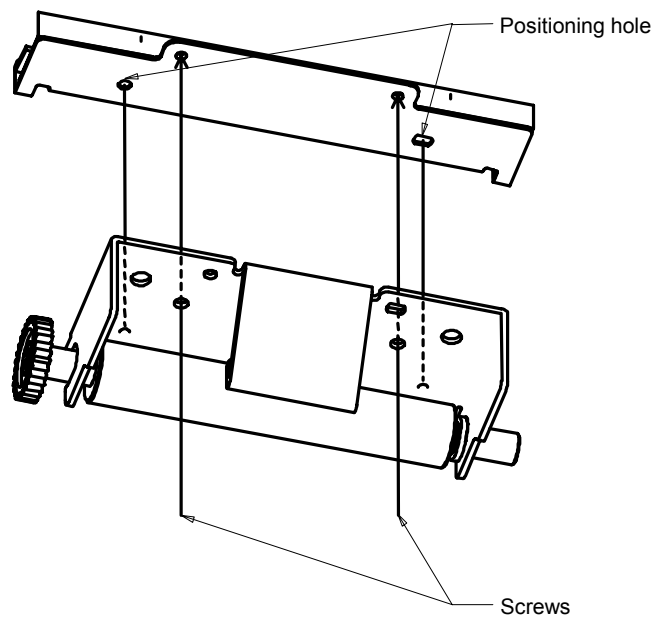

Figure 9-3 Installing Autocutter Unit (Fixing blade unit)

9.1.2 Clearing a Paper Jam in the Autocutter

Owing to the paper jammed, if the cutter has been locked during paper cutting, power off the motor immediately and cancel the lock by performing the following procedures manually.

- (1) Tear transparent film from the upper surface of the autocutter (**Figure 9-4 (1)**), turn the knob in the direction shown in **Figure 9-4 (2)** until the entire hole of the warm wheel can be seen from the standby position confirmation window and retreat the movable blade. (**Figure 9-4 (2)**)

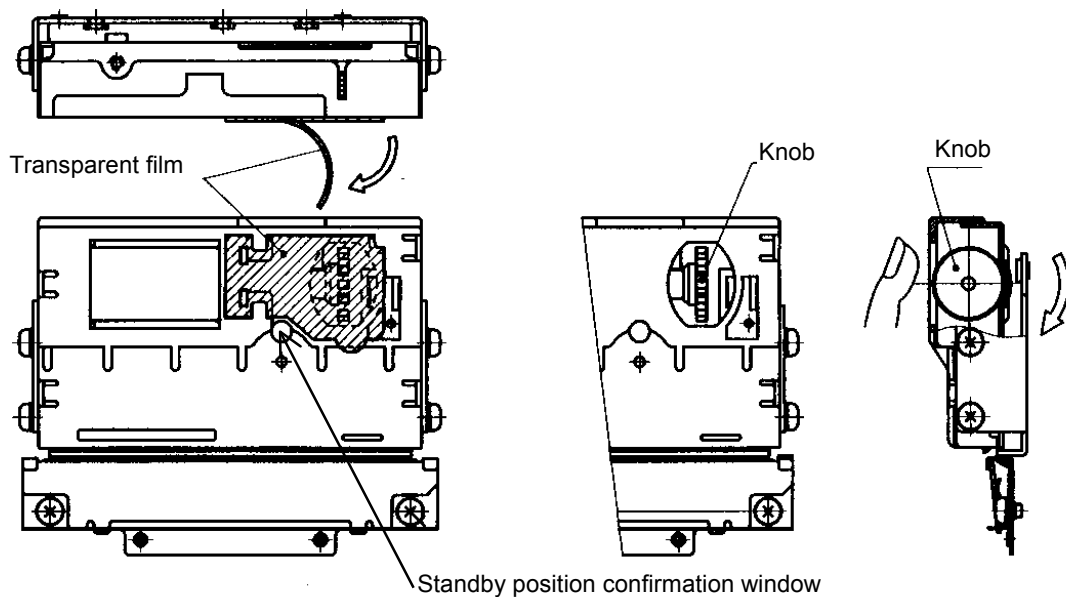

Figure 9-4 Clearing a Paper Jam in the Autocutter

Open the platen after retreating the movable blade with the above way, and then clear a paper jam.

9.1.3 Consideration for Outer Case Design

- (1) Design the outer case of the paper outlet side of the autocutter unit so that the paper does not go between the outer case and the autocutter unit.
- (2) The outer case should not change the paper loading direction sharply in the area around the paper outlet.
- (3) The outer case should be designed so that the user's fingers or other objects will not be inserted into the paper outlet.
- (4) Inappropriate positioning of the platen and the printer mechanism may cause cutting failure and/or paper jam. Pay special attention when designing the outer case. Refer to "6.4 WHERE TO MOUNT THE PLATEN UNIT" for positioning the platen and the mechanical unit.

Figure 9-5 shows a sample outer case design in the platen unit side and Figure 9-6 shows that in the mechanism side.

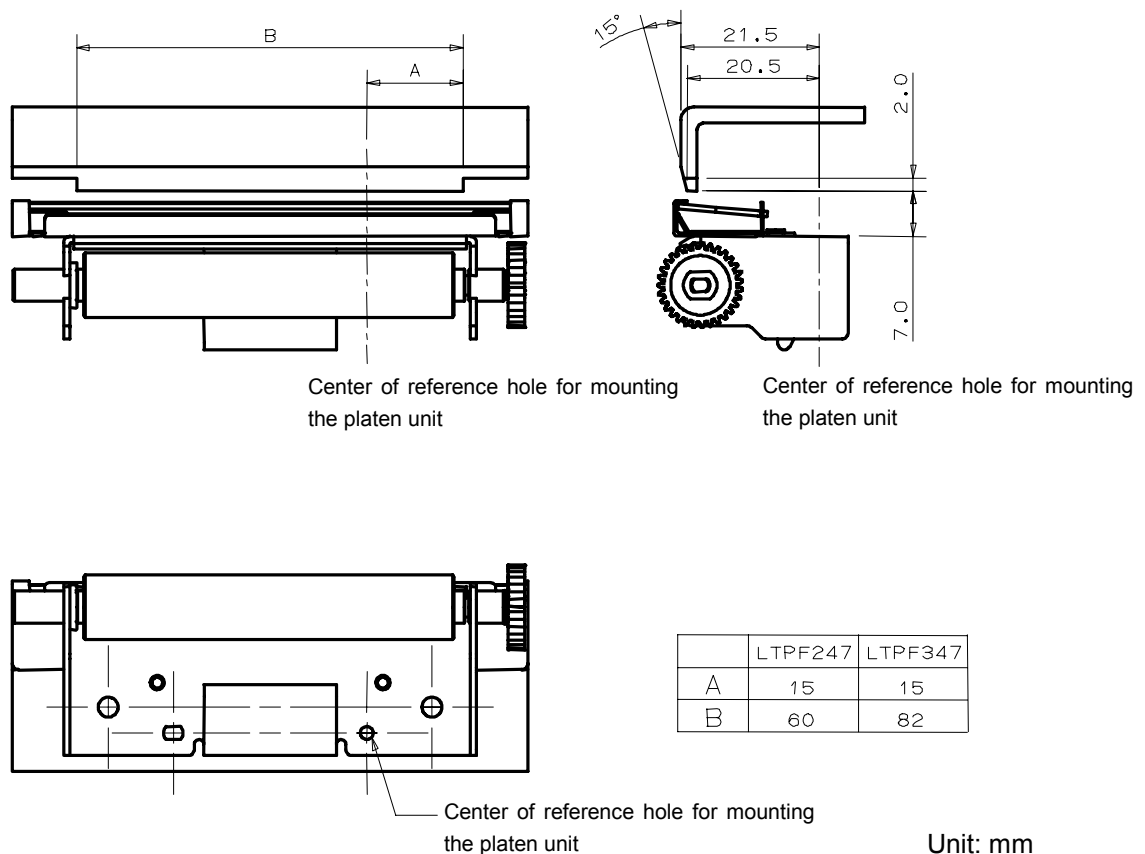
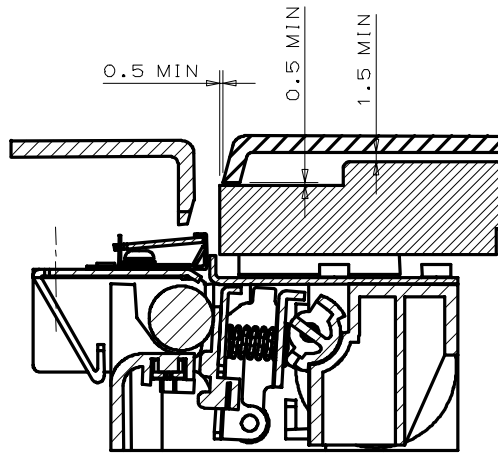

Figure 9-5 Outer Case Design



Unit: mm

Figure 9-6 Outer Case Design Sample (Mechanism Side)

9.1.4 Considerations for Using

- (1) Do not back feed paper after cutting paper using the autocutter unit because it will cause a paper jam.
- (2) To prevent paper from jamming, feed paper or print feed 7 mm or more after cutting paper.
- (3) To make the most efficient use of paper, as shown in **Figure 9-7**, print area A for the next print portion after printing area B, and then cut the paper.

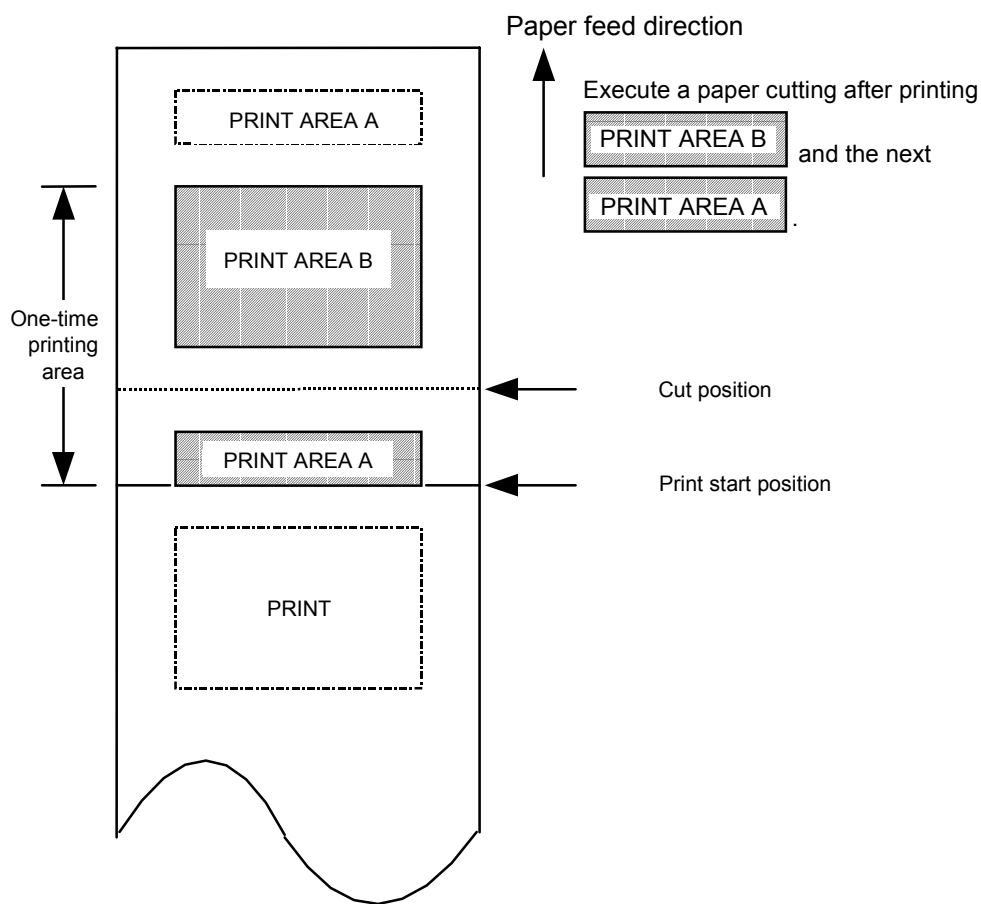

* The distance between the print position and cut position when mounting the autocutter onto the printer is approximately 13 mm.

* Do not perform a consecutive print across print area A and print area B.

Figure 9-7 Using the Paper Effectively When Cutting

9.1.5 Appearance of the Printer with the Autocutter Installed

Figure 9-8 shows an appearance and external dimensions of the LTPF247 with the autocutter installed.

Figure 9-9 shows an appearance and external dimensions of the LTPF347 with the autocutter installed.

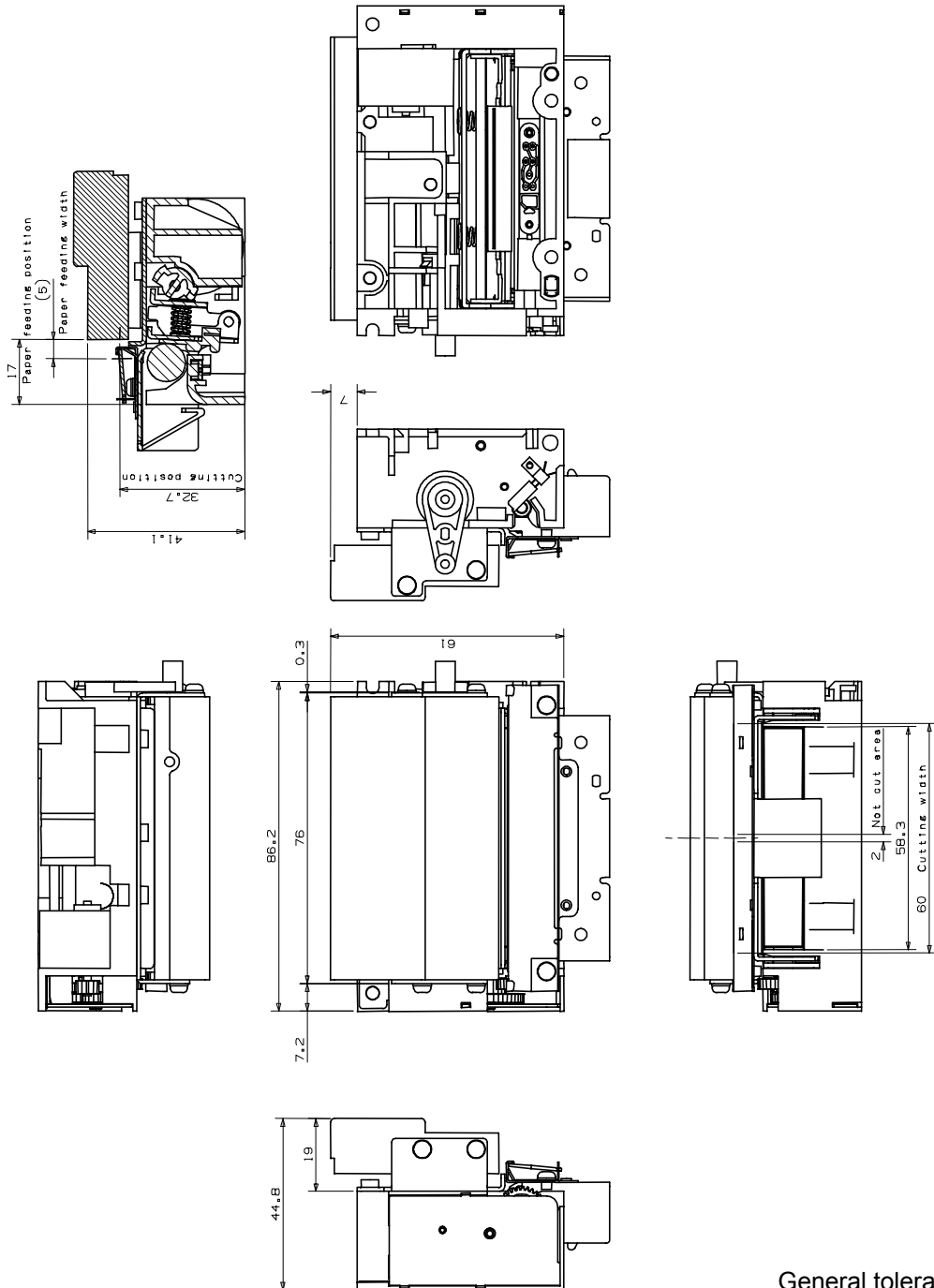

Unit: mm
General tolerance: ± 0.2

Figure 9-8 Appearance of the Printer with the Autocutter Installed (LTPF247 with ACUF224A)

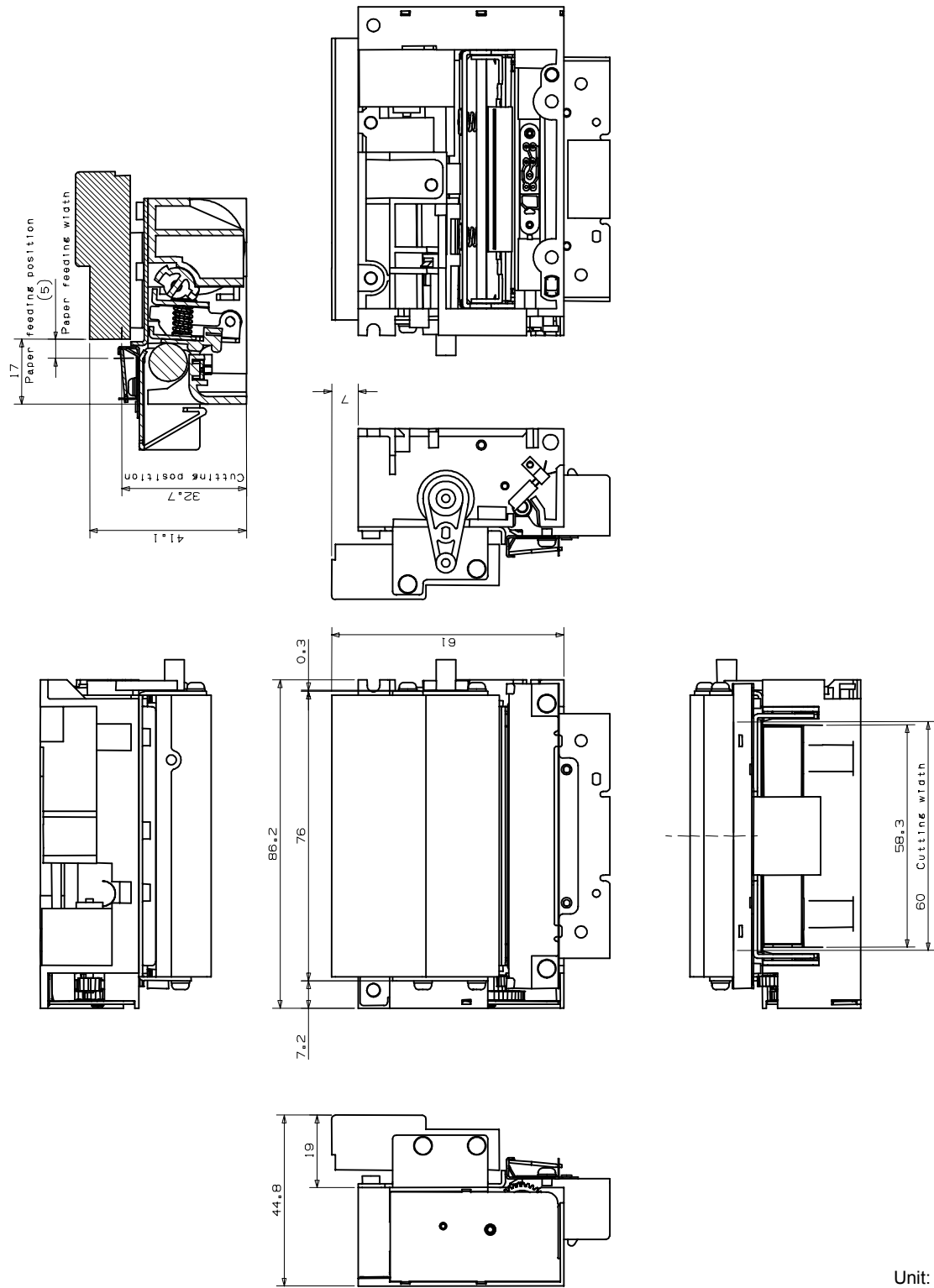

Unit: mm
 General tolerance: ± 0.2

Figure 9-9 Appearance of the Printer with the Autocutter Installed (LTPF247 with ACUF224B)

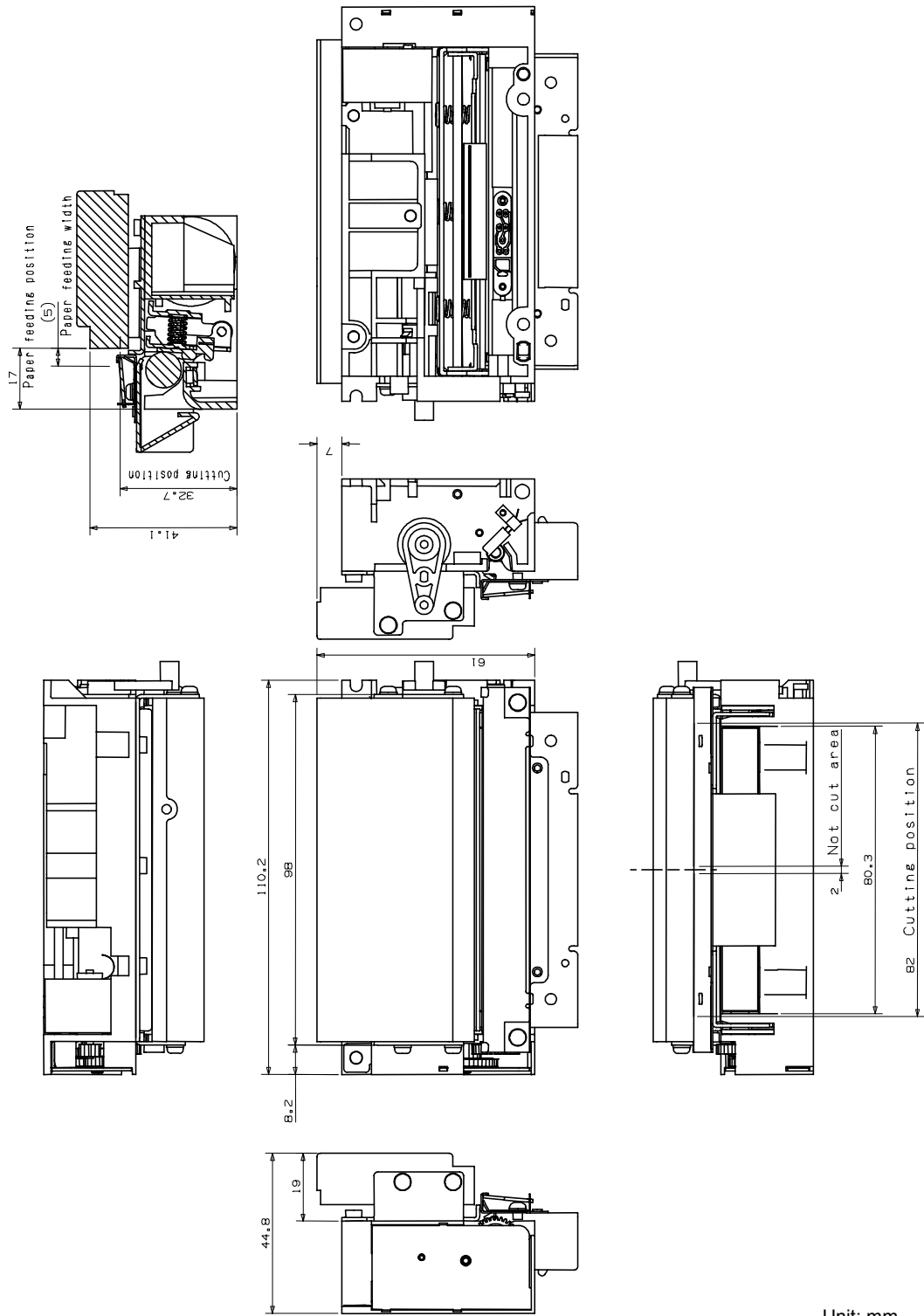

Unit: mm
 General tolerance: ± 0.2

Figure 9-10 Appearance of the Printer with the Autocutter Installed (LTPF347 with ACUF324A)

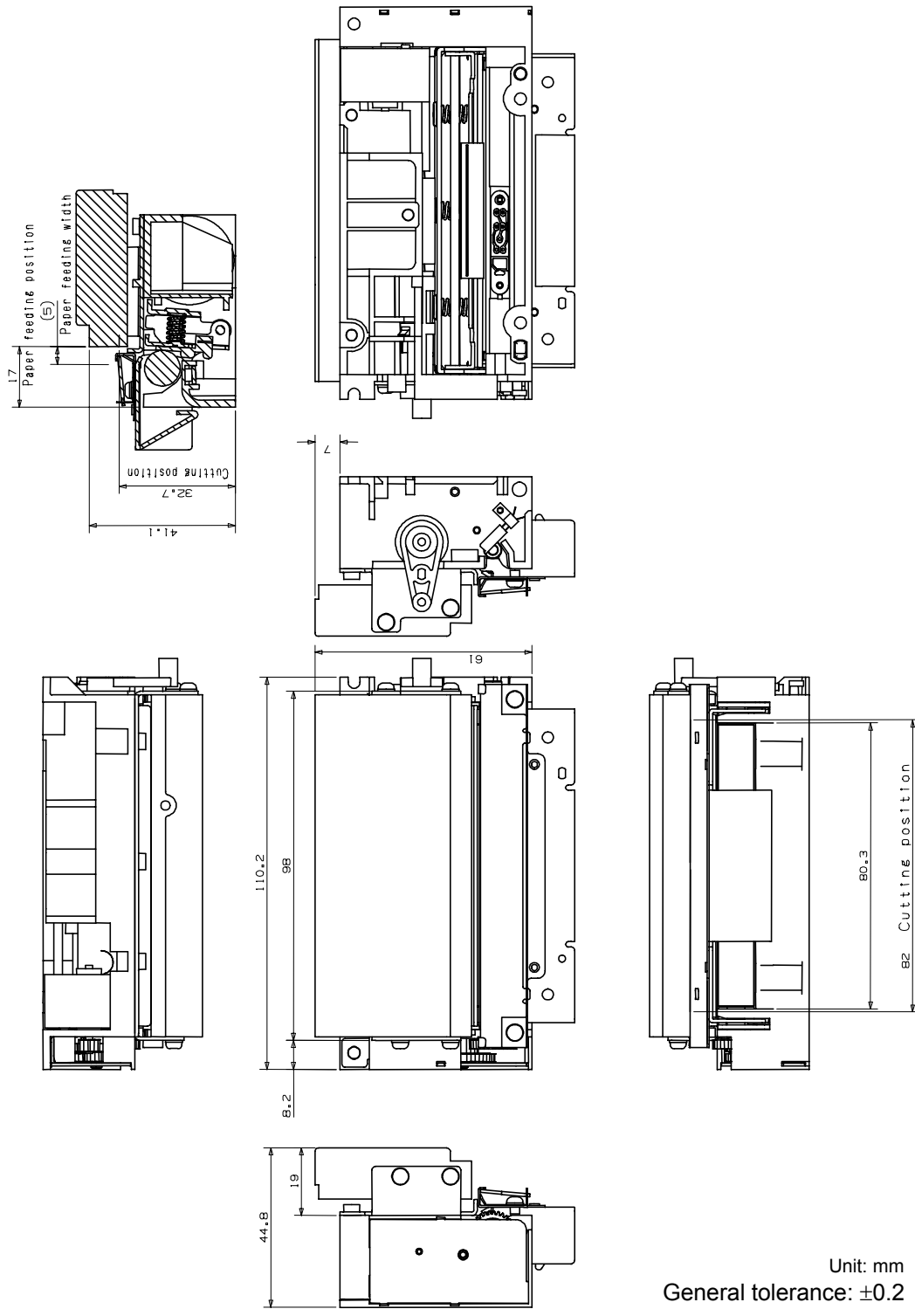

Unit: mm
 General tolerance: ±0.2

Figure 9-11 Appearance of the Printer with the Autocutter Installed (LTPF347 with ACUF324B)

