



EM316SW-XY

Fast Ethernet Multi-Function
Media Converters

User Guide

PN 1288003-001

Revision D2

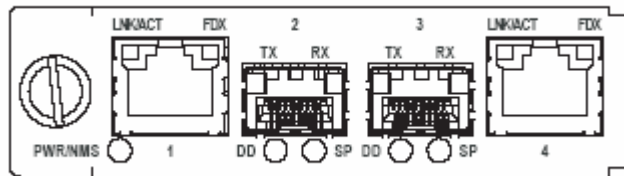

December 12, 2008

Table of Contents

1 Preliminary Considerations	iv
1.1 Trademarks and Copyright	iv
1.2 Customer Support	iv
1.3 Specific Document Information	iv
1.4 Latest Revision and Related Documents	iv
1.5 MRV Regulatory Compliance	v
1.6 General Safety	vi
1.7 Electrical Safety	vi
1.8 Laser Safety	vii
1.9 Passive Laser Equipment Safety	vii
2 Module Introduction	1
2.1 Features	1
2.1.1 Loopback	2
2.1.2 Link Integrity Notification (LIN)	3
2.1.3 LIN with Far End Fault Indication (FEFI)	3
2.1.4 Redundancy	3
2.2 Modes of Operation	4
2.2.1 Dual Repeater (Fiber and Copper)	5
2.2.2 Dual Converter	6
2.2.3 Redundant Link	7
2.2.4 Mixed-Media Switch (4-Port)	8
3 Preparation and Installation	9
3.1 Unpacking the Fiber Driver Module	9
3.2 Front Panel Description	10
3.2.1 Distances	10
3.2.2 SFP Ports	10
3.2.3 LED Definitions	10
3.2.4 LED Display Information	11
3.3 DIP Switches	12
3.3.1 Block Locations	12
3.3.2 Switch Functions and Default Settings	13
Module Installation	16
Cleaning Fibers	18
3.3.3 Working with SFPs	19
3.3.3.1 Cleaning SFPs	19
3.3.3.2 Mylar Tab SFP Modules	20
3.3.3.3 Actuator/Button SFP Modules	21
3.3.3.4 Inserting an Actuator/Button SFP Module	21
3.3.3.5 Bale Clasp SFP Module	22
4 Module Management	23
4.1 Serial Console Interface	24
4.2 MegaVisionJ Embedded GUI Management	24
4.3 EM316LNxNM-OT Command Line Interface (CLI)	25
4.3.1 EM316LNxNM-OT Boot and CLI Login	26
4.3.2 CLI Navigation	27
4.3.3 Login Context Commands and Examples	28
4.3.3.1 “?”	28
4.3.3.2 “show chassis”	29
4.3.3.3 “show slots”	29
4.3.3.4 “show version”	30
4.3.3.5 “show log”	30

4.3.3.6 “show groups”	31
4.3.3.7 “show users”	31
4.3.3.8 “show running-config”	32
4.3.3.9 “show startup-config”	33
4.3.3.10 Displaying and Saving System Parameters	34
4.3.4 Configuration Context	35
4.3.4.1 Restoring Default Parameters	35
4.3.4.2 Configuring System Parameters	36
4.3.5 Chassis Context	37
4.3.5.1 “show”	37
4.3.5.2 Other Commands	38
4.3.6 Slot Context Commands and Examples	39
4.3.6.1 “?”	40
4.3.6.2 “list”	41
4.3.6.3 “show”	42
4.3.7 Port Context Commands and Examples	45
4.3.7.1 “?”	45
4.3.7.2 “list”	49
4.3.7.3 “show”	49
4.3.7.4 “description”	51
4.3.7.5 “show defaults”	52
4.3.7.6 “show config”	53
4.3.7.7 “shutdown” and “no shutdown”	53
4.3.7.8 “lin”	54
4.3.8 RJ-45 Port Commands	55
4.3.8.1 “auto-neg-adv”	55
4.3.8.2 “auto-negotiation”	55
4.3.8.3 “mdi-pinout”	56
4.3.8.4 “duplex”	56
4.3.8.5 “speed”	56
4.3.9 SFP Port Commands	57
4.3.9.1 “loopback”	57
4.3.9.2 “lin”	57
4.3.9.3 “select-link”	58
4.4 Configuration Examples	59
4.4.1 Repeater Mode	59
4.4.2 Converter Mode	61
4.4.3 Redundant Mode	64
4.4.4 Switching Mode	65
5 Appendix	67
5.1 Technical Specifications	67
5.2 Operating Environment	67
5.3 Troubleshooting	67

Table of Figures

Figure 1 -- Loopback on FO1 while FO2 is in normal operation	2
Figure 2 -- Dual Repeater Mode	5
Figure 3 -- Dual Converter Mode	6
Figure 4 -- Redundant Link Mode	7
Figure 5 -- Switching Mode	8
Figure 6 -- Unpacking.....	9
Figure 7 -- EM316SW-XY front panel	10
Figure 8 -- EM316SW-XY front panel	11
Figure 9 -- DIP switch locations	12
Figure 10 -- Remove the required blank panels.....	16
Figure 11 -- Module installation (not all chassis are shown)	17
Figure 12 -- Correctly inserted Fiber Driver module in a powered chassis	17
Figure 13 -- Cleaning cartridge	18
Figure 14 -- Contaminated fiber and clean fiber	18
Figure 15 -- SFP cleaners	19
Figure 16 -- Mylar Tab on SFP Module.....	20
Figure 17 -- Insertion of a Mylar Tab SFP Module	20
Figure 18 -- Removal of a Mylar Tab SFP Module	20
Figure 19 -- Actuator/Button SFP Module	21
Figure 20 -- Insertion of an Actuator/Button SFP Module	21
Figure 21 -- Removal of an Actuator/Button SFP Module.....	21
Figure 22 -- Bale Clasp SFP Module	22
Figure 23 -- Insertion of a Bale Clasp SFP Module	22
Figure 24 -- Removal of a Bale Clasp SFP Module	22
Figure 25 -- EM316LNxNM-OT general commands for EM316SW-XY modules	25

1 Preliminary Considerations

1.1 Trademarks and Copyright

All trademarks are the property of their respective holders.

MRV Communications reserves the right to make changes to technical specifications and documentation without notice in order to improve reliability, function, or design. The user assumes sole responsibility for applying the information supplied herein.

Copyright © 2008 by MRV Communications, Inc. All rights reserved.

1.2 Customer Support

Before contacting customer support, look for software updates, technical specifications, and frequently asked questions (FAQ) online at the MRV support website: <http://service.mrv.com>. The website includes information regarding software updates, technical specifications, frequently asked questions (FAQ), and contact information.

Contact help online by sending email to support@mrv.com or through the website request link at <http://service.mrv.com/support/forms/supportcall.cfm>.

MRV customer support telephone numbers:

MRV Americas (US, Canada, Latin America)	+1-800-435-7997 or +1-978-952-4888
MRV Europe	+49-6105-2070
MRV International	+972-4-993-6200

Include the following important information when opening a support case.

- Site ID or company name
- Contact information
- Model or product name
- Serial number
- Top assembly revision (see label on device)
- Brief problem or question including a description of the host network environment
- Attenuation data for applicable high-speed fiber links
- Urgency of the issue

1.3 Specific Document Information

Document Number: P/N 1288003-001, Rev D2
Document: EM316SW-XY User Guide
Release Date: December 12, 2008 1:36:06 PM

1.4 Latest Revision and Related Documents

The latest revision of MRV documents may be found at: <http://www.mrv.com>. MRV produces Release Notes for Fiber Driver modules as required.

1.5 MRV Regulatory Compliance

Contact your sales representative for more regulatory compliance information regarding specific MRV products or product families.

Fiber Driver Chassis

Compliance: FCC Part 15 (Class A); IC (Class A); EMC Directive: Emission (Class A) and Immunity; LVD Directive: Electrical Safety; CE Marking; TUV CUE Mark (Canada, USA, EU); GOST; RoHS Directive, WEEE Directive: Wheelie Bin Mark; ETSI, NEBS, C-Tick

Fiber Driver Modules

Compliance: FCC Part 15 (Class A); IC (Class A); EMC Directive: Emission (Class A) and Immunity; LVD Directive: Electrical Safety; RoHS Directive, WEEE Directive: Wheelie Bin Mark; ETSI

Optical and Copper Transceivers

Compliance: FCC Part 15 (Class A); IC (Class A); EMC Directive: Emission (Class A) and Immunity; LVD Directive: Electrical Safety; CE Marking; TUV; UL, CSA, RoHS Directive, ETSI, NEBS, compliant with EN 60825-1/A1:2002 Safety of Laser Products

China RoHS Disclosure 中国 RoHS 声明

Component Name 部件名称	Pollution Control Logo 污染控制标志	Hazardous Substance Name 有毒有害物质或元素					
		Lead 铅 (Pb)	Mercury 汞 (Hg)	Cadmium 镉 (Cd)	Hexavalent Chromium 六价铬 Cr (VI)	Polybrominated Biphenyls 多溴联苯 (PBB)	Polybrominated Diphenyl Ethers 多溴二苯醚 (PBDE)
Fiber Driver Chassis, Modules and Accessories 光纤驱动器 机箱, 组件和附件		X	O	O	O	O	O
Pluggable Optics 插入式光学器件		X	O	O	O	O	O
Power Supplies 电源		X	O	O	O	O	O

O: Indicates that this hazardous substance contained in all of the homogeneous materials for this component is below the limit requirement in SJ/T11363-2006.







O: 表示该有毒有害物质在该部件所有均质材料中的含量均在 SJ/T11363-2006 标准规定的限量要求以下。

X: Indicates that this hazardous substance contained in at least one of the homogeneous materials used in this component is above the limit in SJ/T11363-2006. Contain lead in solder.







X: 表示该有毒有害物质至少在该部件的某一均质材料中的含量超出 SJ/T11363-2006 标准规定的限量要求，焊锡中含铅。

Table of Hazardous Substances Name and Concentration 有毒有害物质名称及含量的标识格式





1.6 General Safety

	WARNING: Two people must lift large cabinet chassis. Lift with your legs and a straight back to prevent injury. Lift with both hands, grasping underneath the lower edge. To prevent damage to the chassis and components, do not lift the chassis with the handles on the power supplies and interface processors, or by the plastic panels on the front of the chassis. These handles are not designed to support the weight of the chassis.
	WARNING: Do not stack unsecured equipment. Falling equipment can cause severe bodily injury and equipment damage.
	WARNING: To prevent bodily injury when mounting or servicing this equipment in a rack, take all precautions to ensure that the system remains stable. Follow the guidelines below: <ul style="list-style-type: none"> — Mount devices from the bottom of an empty rack. — Mount the heaviest rack devices at the bottom of the rack. — Install rack stabilizing equipment before mounting or servicing rack devices.
	WARNING: Do not operate the equipment with the covers removed. Ensure that all modules are installed, empty slots are covered and lasers outputs plugs are in place.
	WARNING (Proposition 65): Some Fiber Driver products may contain chemicals known to the State of California to cause cancer, birth defects, or other reproductive harm.
	CAUTION: To prevent overheating the equipment, do not operate it in an area that exceeds the maximum recommended ambient temperature. To prevent airflow restriction, provide at least 3 inch (7.6 cm) of clearance around the ventilation openings.
	CAUTION: Only trained and qualified service personnel (see IEC 60950-1) should install, replace, or service the equipment.

1.7 Electrical Safety

	WARNING: This equipment is intended to be grounded. Ensure that the host is connected to earth ground during normal use.
	WARNING: Use only shielded and grounded cables to ensure compliance with FCC rules.
	WARNING: Electrical equipment relies on the protective devices in the building installation for protection against short-circuit, over-current, and earth (ground) fault. Ensure that the protective devices in the building installation are properly rated to protect the equipment. Listed or certified fuse or circuit breaker must be used on all current-carrying conductors.
	WARNING: Install the equipment near power outlet. The power cord plug is the equipment main disconnecting device and must be easily accessible at all times. Unplug the power cord before you work on a system that does not have an on/off switch.
	CAUTION: The equipment is not intended for direct copper connection to Public Switched Telephone Network or Telecommunication Network (EU) connection ports.
	Install MRV equipment in accordance with applicable building and electrical codes such as: NFPA NEC 70, CEC, Part 1, CSA C22.1, IEC 60364, BS7671, etc.
	Provide proper grounding when servicing and operating electrical equipment to avoid electrostatic discharge (ESD) that can damage equipment. Use antistatic carriers to transport exposed electronic devices, protective clothing including grounding straps, antistatic table and floor mats, furniture grounding, and any other safety devices recommended by the industry.

1.8 Laser Safety

	WARNING: Do not open laser devices for service. Removing the cover may cause exposure to harmful laser beams. Return defective laser devices to the vendor for service.
	WARNING: Un-terminated connectors or fiber cable ends may emit invisible laser radiation. Do not view them directly with optical instruments such as eye loupes, magnifiers, or microscopes. The amplified laser output can dramatically increase eye hazard.
	WARNING: This equipment is intended for use with Class 1 pluggable (SFP, XFP, GBIC) fiber optics transceivers that carry a label indicating the following specifications: <ul style="list-style-type: none"> – Classification as a Class 1 Laser product. – Compliance with Food and Drugs Administration Center for Radiological Health (FDA CDRH) performance standards, 21 CFR, 1040.10, and 1040.11. – Certification from Nationally Recognized Testing Laboratory (NRTL), CSA, or TUV.
	WARNING: Some fiber optics modules (EM316EDFA) may contain Class 1M levels of invisible laser radiation. Class 1M equipment must be installed in a <i>restricted</i> location that is only accessible to authorized personnel with laser safety training.
	WARNING: Laser products labeled as Class 1M may have internal laser diodes containing Class 3B lasers.



1.9 Passive Laser Equipment Safety

Passive devices require no external power source for operation. Although these devices may be deployed anywhere a fiber cable may be routed, access to the fiber ends and connections constitutes potential risks with live laser transmissions. The passive equipment is intended for add/drop and multiplex/de-multiplex networking with multiple **Class 1** laser fiber signals mapping to one signal of CWDM (1,310nm to 1,610nm), DWDM (1,520nm to 1565nm), and add/drop modules.

Measure or calculate risk potential separately for skin and retinal hazards, with care not to exceed the Class 1 laser hazard level (10 dbm). See IEC 60825-2 for details.

IEC 60825-2, D.5.1 - Aggregated Wavelengths on a Fiber (summary)

When more than one wavelength is combined on the same fiber as in a WDM system, then the hazard level depends on aggregated power levels. Hazards are always cumulative for exposure to wavelengths usually used in optical fiber communication systems.

	WARNING: Only trained and qualified personnel (IEC 60950-1) should install, replace, or service passive equipment.
	WARNING: These passive optical devices are intended for connecting Class 1 laser inputs only. Use of other than Class 1 laser inputs may result in equipment damage or hazardous radiation exposure on the equipment output.
	WARNING: Un-terminated connectors or fiber cable ends may emit invisible laser radiation. Do not view directly with optical instruments such as eye loupes, magnifiers, or microscopes because the amplified light can damage eyes.

2 Module Introduction

The Fiber Driver EM316SW-XY is a highly configurable multi-function module that can perform the functions of hundreds of less sophisticated devices. The SW-XY can operate in four modes. Each of these applications is described later in this section.

- Repeater
- Converter
- Redundant Fiber Link
- Switch

The SW-XY features two RJ-45 copper Ethernet ports (P1 and P4) and two SFP sockets (P2 and P3). SFP transceivers are available from MRV to support virtually any standard fiber optic or copper Ethernet protocol.

2.1 Features

This modular design supports a wide variety of module and port features. Some important features are listed below.

- Copper 10/100Base-TX with full wire-speed capabilities
- Maximum packet size of 1916 bytes
- Auto-negotiation
- Half/full-duplex sensing
- MDI/MDIX detection
- Fault status propagation (LIN and FEFI) except in switch mode
- Management tools for status and module control
- Port status through front panel LEDs and module management
- Hot-swap support

The LIN, MDI/MDIX, and Loopback features are configurable, and each item is introduced below.

2.1.1 Loopback

Loopback tests and verifies the link integrity. It is available on the fiber optic ports (P2 and P3) only, and it operates in all four operational modes.

Loopback directs received data on a port to the transmitter to test the fiber optic link end-to-end from the remote converter.

The figure below illustrates loopback with a pair of EM316SW-XY modules. In the drawing, FO1 and FO2 refer to fiber optic ports P2 and P3.



Figure 1 -- Loopback on FO1 while FO2 is in normal operation

The two loopback switches (loopback and loopback2) correlate to the two converters on the module. “Loopback” controls port P2 and “Loopback2” controls port P3. The switch settings apply to operation in all operational modes. In Redundant Link mode, both the loopback switches must be set to the same position (either both ON or both OFF) for supported operation.

2.1.2 Link Integrity Notification (LIN)

LIN is not available in switch mode.

A single DIP switch (LIN EN) activates LIN for the entire module except in switch mode. If this switch is OFF, then LIN cannot be activated even through software management. In the other operational modes, ports on the EM316SW-XY are paired as converters or repeaters. LIN applies to each port pairing with mode considerations noted in the corresponding sections. In Redundant Link mode, changing LIN status on any port adjusts all ports (P1, P2, and P3) to the same setting. Port P4 is disabled in this mode.

When a link fault is detected on a paired port, LIN shuts down the transmitter on the partner port to notify connected equipment dependent the lost link. This status propagation allows switches, routers, and other link-state dependant devices to accurately react to link conditions.

With standard LIN operation (without FEFI), digital diagnostics traps are suppressed. The LED indicates beaconing with regular flashes while a link is down and data activity with irregular flickers otherwise. A beaconing port is considered to have no signal.

LIN is especially valuable in fault-tolerant designs.

2.1.3 LIN with Far End Fault Indication (FEFI)

The SFP ports support FEFI, which conforms to IEEE 802.3u 100BASE-FX specifications.

When an SFP port detects a link failure on its receiver, it sends an FEFI (Far End Fault Indication) signal to the remotely connected device as notice of a link fault. It may also receive an FEFI signal sent from the remote link partner, which causes it to disable the paired copper Ethernet port transmitter.

FEFI is always enabled on the EM316SW-XY, but it is used only as requested by LIN and configured through either DIP switches (FEFI and FEFI2) or management module administration.

In Redundant Link mode, enable both FEFI DIP switches (FEFI=ON and FEFI2=ON) to use FEFI with LIN. This configuration provides “1:1” link protection to the redundant link. The dual-homing configuration (separate remote optical devices) is not supported.

2.1.4 Redundancy

The EM316SW-XY redundant mode (discussed in the following section) pairs the two SFP ports (P2 and P3) as a self-healing link based on signal detection. The switch-over time when the active fiber link fails is very short, which can allow transparent failover.

LIN disables the Ethernet port P1 only if BOTH fiber channels fail simultaneously. Port P4 is disabled in redundant mode.

2.2 Modes of Operation

The EM316SW-XY supports four different operational modes.

1. Dual Repeater (Fiber and Copper)
2. Dual Converter
3. Redundant Link
4. Switch (4-Port, mixed-media)

This section describes these modes and required DIP switch settings.

Select the operational mode with the DIP switches labeled MODE1 and MODE0, switches 5 and 6 on switch block 1 nearest the front panel of the module.

Mode	DIP Switches		Port Grouping
	MODE1	MODE0	
Dual Repeater	ON	ON	Fiber Repeater: ports P2 & P3 Copper Repeater: ports P1 & P4
Dual Converter	ON	OFF	Converter 1: ports P1 & P2 Converter 2: ports P3 & P4
Redundant Link	OFF	ON	Redundant: fiber optic ports P2 & P3 Local: copper port P1 Unused: copper port P4
Mixed-Media Switch	OFF	OFF	All ports (P1, P2, P3, P4)

2.2.1 Dual Repeater (Fiber and Copper)

MODE1 ON
 MODE0 ON

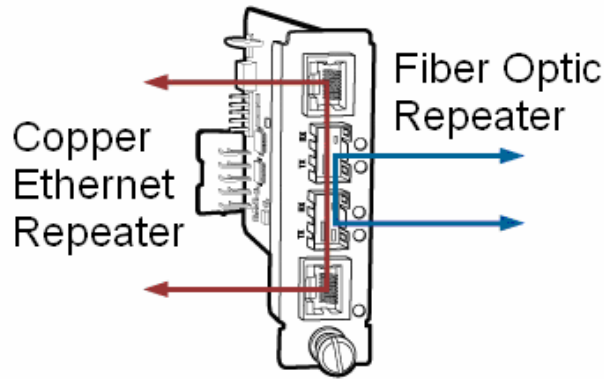

Figure 2 -- Dual Repeater Mode

In Dual Repeater mode, the module acts as a pair of repeaters.

Fiber Optic repeater between 100Base-FX ports	SFP-based interfaces
Copper repeater between 10/100 Base-TX ports	RJ-45 copper interfaces

The copper repeater can be used as a distance extender in a copper infrastructure to extend a link beyond the 300 foot (100m) limit. Each RJ-45 interface supports speed and duplex matching and automatic MDI/MDIX detection. LIN applies to this configuration, as well.

With LIN enabled, loss of link at a port receiver disables the transmitter of the paired port. There is no beaconing on an inactive link in Dual Repeater mode.

2.2.2 Dual Converter

MODE1 ON
MODE0 OFF

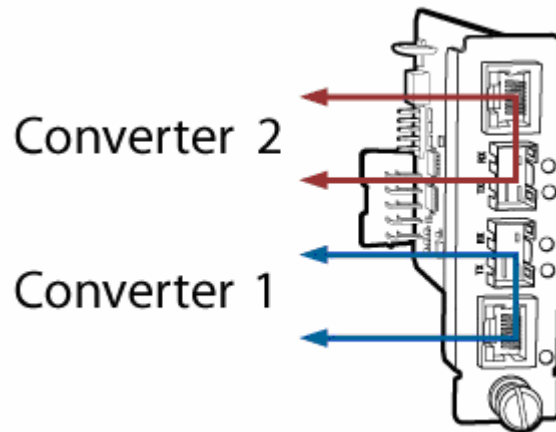

Figure 3 -- Dual Converter Mode

In Dual Converter mode, the module incorporates two independent “copper 10/100 to Fiber Fast Ethernet converters” for the price of a single converter. This combination doubles the density of a central office chassis, allowing up to 30 converters in a managed 16-slot chassis.

The first converter uses ports P1 and P2. The second converter uses ports P3 and P4.

With LIN enabled, loss of link at a port receiver disables the transmitter of the paired port. Downstream switches, routers, and other link-state dependant devices can accurately react to changing link conditions. This feature is especially valuable in fault-tolerant network designs.

The module supports both LIN and FEFI for link status propagation in Dual Converter mode. In this mode, LIN offers two functional options.

- 1) The basic LIN (FEFI disabled) maintains backwards compatibility with all MRV Fast Ethernet media conversion modules as well as the common Far End Fault Indication (FEFI). The SFP transceiver beacons (transmits a periodic signal) if there is no signal detected on its receiver. This signal notifies the other side about the detected problem.
- 2) A revised LIN (FEFI enabled), which uses the FEFI standard to notify the other side about a problem in the receive fiber. Beaconsing is not necessary in this case.

The revised LIN is recommended if the other side of the link supports FEFI. Use basic LIN if the remote device does not support FEFI.

A single DIP switch controls LIN for both converters, so both will use either LIN enabled or disabled.

2.2.3 Redundant Link

MODE1 **OFF**
MODE0 **ON**

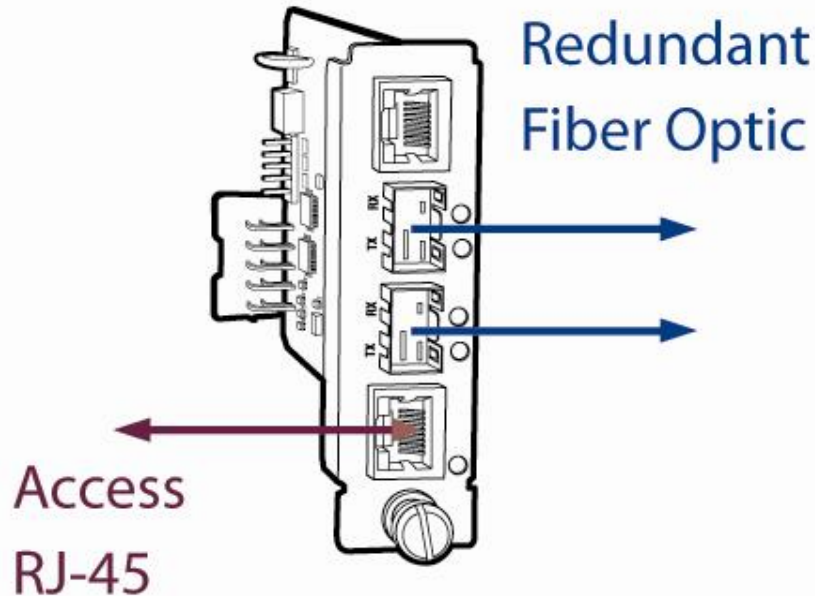

Figure 4 -- Redundant Link Mode

In Redundant Link mode, the module acts as a copper to redundant fiber (100Base-FX) converter. This configuration requires optical SFPs installed in ports P2 and P3 to support a pair of redundant fiber optic paths. Ethernet port P4 is disabled in this mode; only description commands will have any effect on P4. The Redundant Link mode provides “1:1” link protection. Dual-homing is not supported.

In this mode, the EM316SW-XY can pass link status with LIN or with the industry standard Far End Fault Indication (FEFI). Implementing both tools allows for backwards compatibility with the full set of MRV Fast Ethernet media conversion solutions while supporting standard connectivity to any standard Fast Ethernet fiber optic port.

With LIN enabled, loss of link at BOTH fiber ports (P2 and P3) disables the transmitter of the access (Ethernet) port (P1). If one fiber optic channel fails while the other fiber optic channel is operational, LIN does not interrupt the data. Downstream switches, routers, and other link-state dependant devices can accurately react to changing link conditions. This feature is especially valuable in fault-tolerant network designs. Set both DIP switches (FEFI and FEFI2) ON to enable FEFI with LIN in Redundant Link mode.

The “select-link” command is enabled for ports P2 and P3 in Redundant Link mode to force a port to active if it has an available link. There is no default or preferred port, so the first link established becomes active. The “shutdown” command is not available for redundant ports P2 and P3.

2.2.4 Mixed-Media Switch (4-Port)

MODE1 OFF
MODE0 OFF

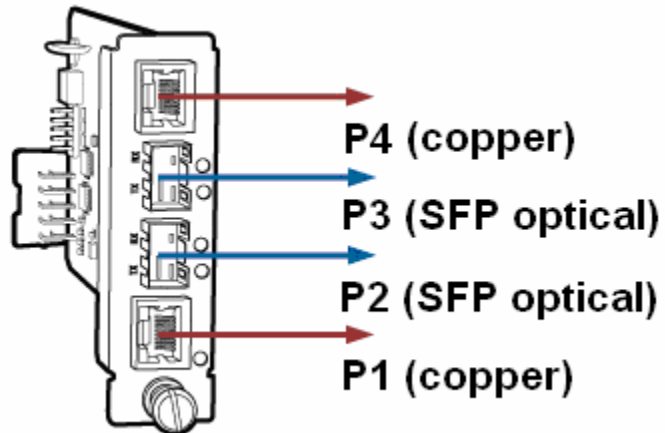

Figure 5 -- Switching Mode

In Switch mode, the module acts a mixed-media Ethernet Switch with two 10/100Base-TX copper interfaces and two fiber-optic SFP-based 100 Base-FX interfaces.

The mixed-media switch allows copper Ethernet traffic access to a linear fiber-optic Ethernet network.

LIN is not supported in this mode.

3 Preparation and Installation

3.1 Unpacking the Fiber Driver Module

- Step 1.** Open the cardboard box.
- Step 2.** Remove the static bag containing the module.
- Step 3.** Check for additional or loose accessories in the box.
Parts may move under the module packing tray during shipment.

In the unlikely event that a part is missing from the contents, contact your authorized MRV dealer or representative. If product return becomes necessary, ship the unit in its original packaging and container.

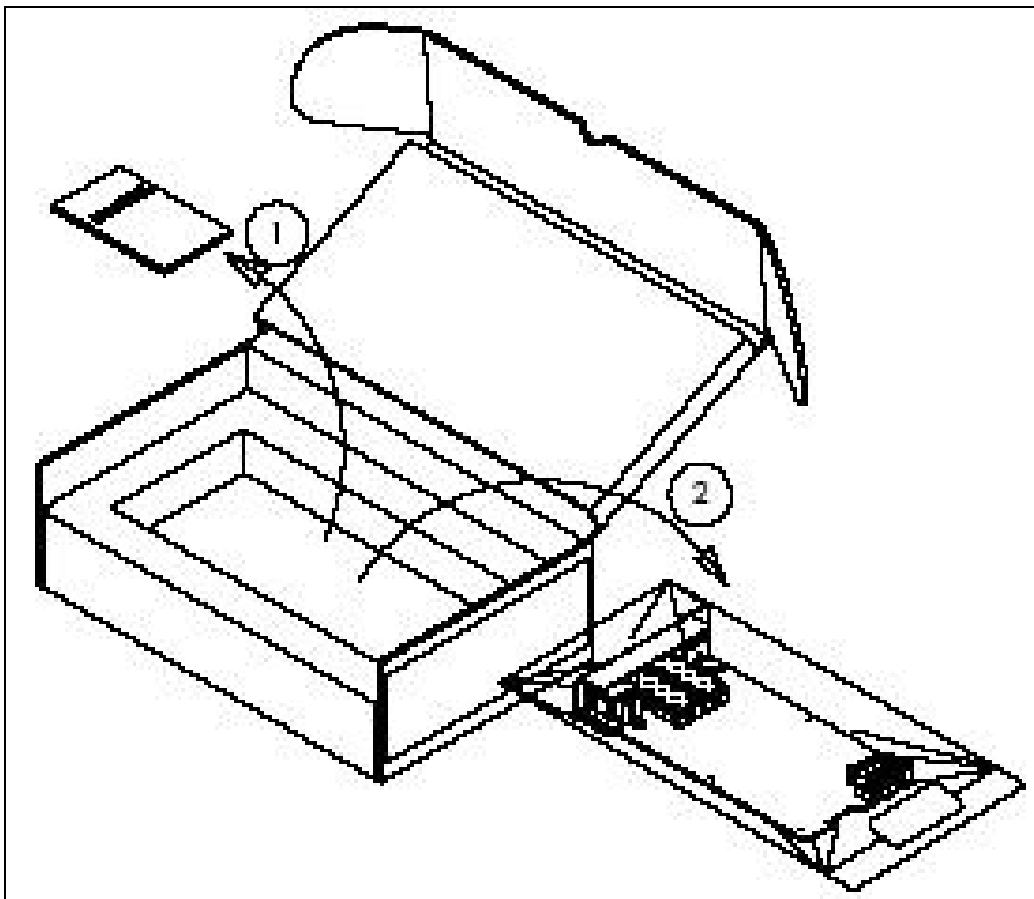

Figure 6 -- Unpacking

3.2 Front Panel Description

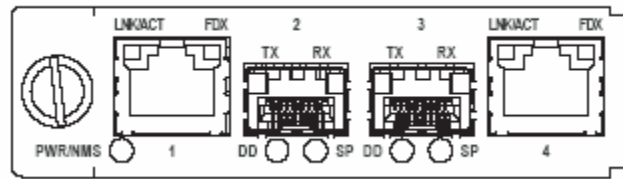

Figure 7 -- EM316SW-XY front panel

The EM316SW-XY module is equipped with the following interfaces.

Port 1 (1): 10/100 Base-T UTP RJ-45

Port 2 (2): 100 Base-FX, SFP- Port

Port 3 (3): 100 Base-FX, SFP Port

Port 4 (4): 10/100 Base-T UTP RJ-45

3.2.1 Distances

Maximum distance for SFP ports is SFP dependent.

Maximum distance for ports 1 and 4 (UTP) 100 meters.

3.2.2 SFP Ports

Ports 2 and 3 (SFP) can be configured as redundant link ports (Redundant Link Mode) or individually operated (Dual Converter or Switching Mode)

3.2.3 LED Definitions

PWR/NMS: Indicates module power and loopback mode status of at least one port.

P1 UTP: LNK/ACT blinking on link and activity
FDX is lit when full duplex link is configured or established.

P2 DD: Digital Diagnostic indicator for the SFP inserted in Port 2.

P2 SP: Indicates presence of SFP and presence of link and activity.

P3 DD: Digital Diagnostic indicator for the SFP inserted in Port 3.

P3 SP: Indicates presence of SFP and presence of link and activity.

P4 UTP: LNK/ACT blinking on link and activity
FDX is lit when full duplex link is configured or established.

3.2.4 LED Display Information

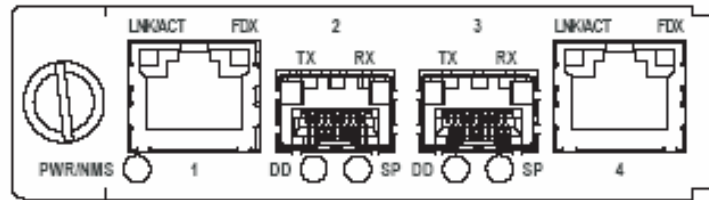

Figure 8 -- EM316SW-XY front panel

LED	Color	Solid or Blink	Explanation
PWR/NMS	OFF green green	n/a solid blink	No power to unit Power OK At least one port in loopback
P1 UTP LNK/ACT	OFF amber green amber green	n/a solid solid blink blink	No link detected 10 Mbps link 100 Mbps link Data flow with 10Base-T protocol Data flow with 100Base-T protocol
FDX	OFF green	n/a solid	Half duplex Full duplex
P2 SFP DD	OFF green amber	n/a solid solid	No SFP with DD support detected No alarm Alarm
SP	green amber green/amber	solid solid blink	SFP present and link present SFP inserted, no link Link present and activity
P3 SFP DD	OFF green amber	n/a solid solid	No SFP with DD support detected No alarm Alarm
SP	green amber green/amber	solid solid blink	Link present SFP inserted, no link Link present, activity
P4 UTP LNK/ACT	OFF amber green amber green	n/a solid solid blink blink	No link detected 10 Mbps link 100 Mbps link 10 Mbps Data flow 100 Mbps Data flow
FDX	OFF	n/a	Half duplex
	green	solid	Full duplex

3.3 DIP Switches

The default configuration is established by the firmware preloaded onto the module. The EM316SW-XY is configured at the factory to work “out of the box” in “Dual Converter” mode with management enabled.

Use the module in pairs to operate the EM316SW-XY in unmanaged mode. Select the functional modes with DIP switches MODE1 and MODE0 on switch block 1 (nearest the front panel).

In addition to the four operational modes, LIN, Auto-MDI, and Loopback may also be configured.

3.3.1 Block Locations

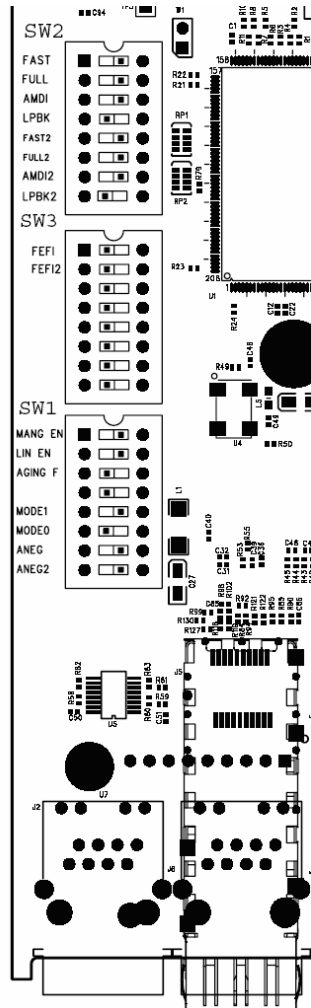

Figure 9 -- DIP switch locations

3.3.2 Switch Functions and Default Settings

The switch block number is not sequential on the module. Carefully verify the switch block number and placement before changing switch settings.

Switch Block 1*

<u>DIP Switch</u>	<u>DIP Switch Name</u>	<u>Setting</u>	<u>Description</u>	
1	MANG EN	ON (up)	Control by NM is enable	
		OFF (down)	Control be NM is disable	
2	LIN EN	ON (up)	LIN enable	
		OFF (down)	LIN disable	
3	AGING F	ON (up)	NOT USED	
		OFF (down)		
4		ON (up)	NOT USED	
		OFF (down)		
5	MODE1	ON (up)	See table below	
		OFF (down)		
6	MODE0	ON (up)		
		OFF (down)		
7	ANEG	ON (up)		P1 Auto Negotiation is enable
		OFF (down)		P1 Auto Negotiation is disable
8	ANEG2	ON (up)	P4 Auto Negotiation is enable	
		OFF (down)	P4 Auto Negotiation is disable	

SW1-5, SW1-6 – Operational Modes

Mode	DIP Switches		Port Grouping
	MODE1	MODE0	
Dual Repeater	ON	ON	Fiber Repeater: ports P2 & P3 Copper Repeater: ports P1 & P4
Dual Converter (default mode)	ON	OFF	Converter 1: ports P1 & P2 Converter 2: ports P3 & P4
Redundant Link	OFF	ON	Redundant: fiber optic ports P2 & P3 Local: copper port P1 Unused: copper port P4
Mixed-Media Switch	OFF	OFF	All ports (P1, P2, P3, P4)

Switch Block 2* (SW2)

<u>DIP Switch</u>	<u>DIP Switch Name</u>	<u>Setting</u> Bold = Defaults	<u>Description</u>
1	FAST	ON (up)	P1 Forced 100Base-T if ANEG is off
		OFF (down)	P1 Forced 10Base-TX if ANEG is off
2	FULL	ON (up)	P1 Forced Full-Duplex if ANEG is off or failed
		OFF (down)	P1 Forced Half-Duplex if ANEG is off or failed
3	AMDI	ON (up)	P1 Auto MDI is enabled
		OFF (down)	P1 Auto MDI is disabled if ANEG is off
4	LPBK	On (up)	P2 loopback is enabled
		OFF (down)	P2 loopback is disabled
5	FAST2	ON (up)	P4 Forced 100Base-T if ANEG2 is off
		OFF (down)	P4 Forced 10Base-TX if ANEG2 is off
6	FULL2	ON (up)	P4 Forced Full-Duplex if ANEG2 is off or failed
		OFF (down)	P4 Forced Half-Duplex if ANEG2 is off or failed
7	AMDI2	ON (up)	P4 Auto MDI is enabled
		OFF (down)	P4 Auto MDI is disabled if ANEG2 is off
8	LPBK2	ON (up)	P3 loopback is enabled
		OFF (down)	P3 loopback is disabled

* Shaded and bold describe factory default settings

Switch Block 3* (SW3)

<u>DIP Switch</u>	<u>DIP Switch Name</u>	<u>Setting</u>	<u>Description</u>
1	FEFI	ON (up)	P2 Far End fault Indication is used in LIN
		OFF (down)	Far End Fault Indication is not used in LIN
2	FEFI2	ON (up)	P3 Far End fault Indication is used in LIN
		OFF (down)	Far End Fault Indication is not used in LIN
3		ON (up)	NOT USED
		OFF (down)	
4		ON (up)	NOT USED
		OFF (down)	
5		ON (up)	NOT USED
		OFF (down)	
6		ON (up)	NOT USED
		OFF (down)	
7		ON (up)	NOT USED
		OFF (down)	
8		ON (up)	NOT USED
		OFF (down)	

* Shaded and bold describe factory default settings

Module Installation

Fiber Driver modules are hot-swappable and may be inserted into or removed from a supporting chassis at any time. Install the module into a powered Fiber Driver chassis with a cooling fan. Align the edge of the card with the rail of the chassis, slide it into the chassis until firmly seated against the backplane and hand-tighten the thumb screw.

The thumb screw of an installed module is toward the bottom of the BU-16 chassis and to the left in the other chassis.

Tools

- Phillips screwdriver (for some module screws)
- Flat-tip screwdriver

Procedure

Follow all guidelines to eliminate static electricity while handling the module and other electronic devices. Refer to the front of this manual for some suggestions.

Step 1. If a blank panel is covering the target slot, remove it by unfastening the two screws with a 6-inch Phillips screwdriver.

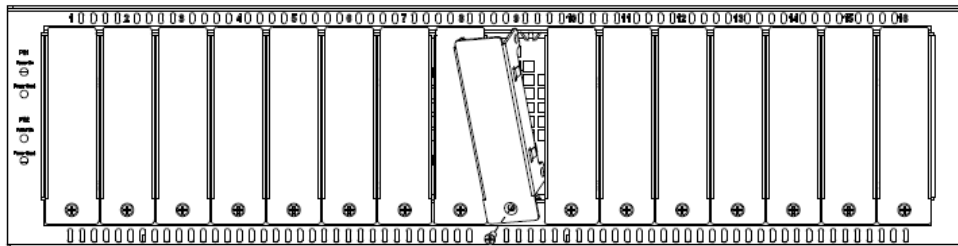

Figure 10 -- Remove the required blank panels

A cover panel or a module must securely cover each chassis slot to comply with FCC regulations. Open chassis slots may emit disruptive signals during operation. Securing modules and panels with appropriate screws is also important for grounding and safety.

Step 2. Install the module inside a Fiber Driver chassis by aligning the edge of the card with the rail of the chassis. Tighten the thumbscrew by hand.

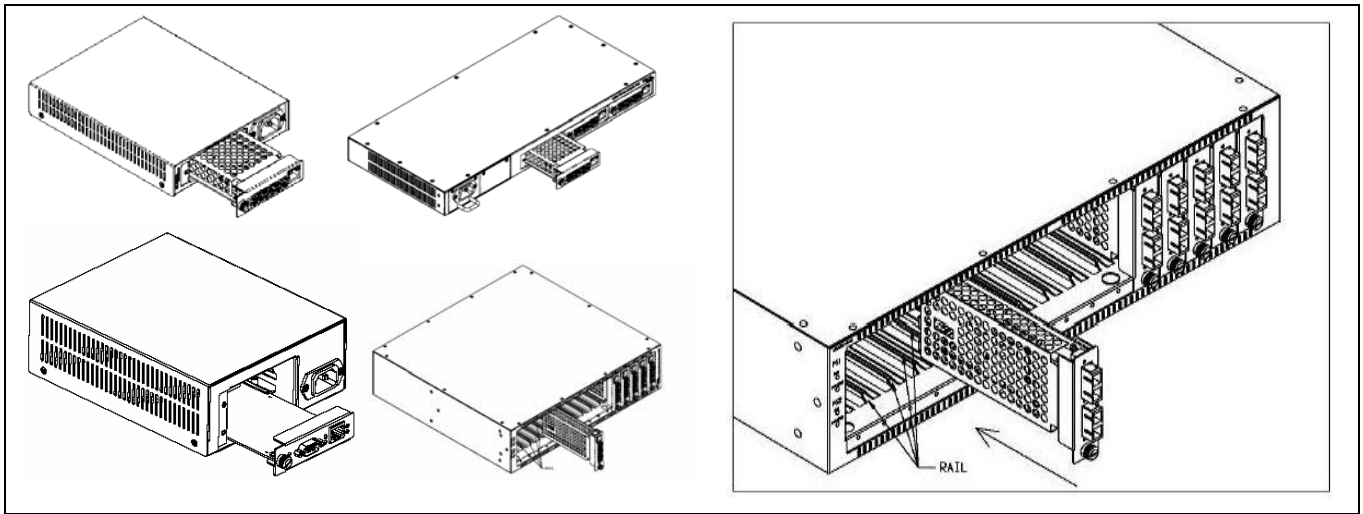

Figure 11 -- Module installation (not all chassis are shown)

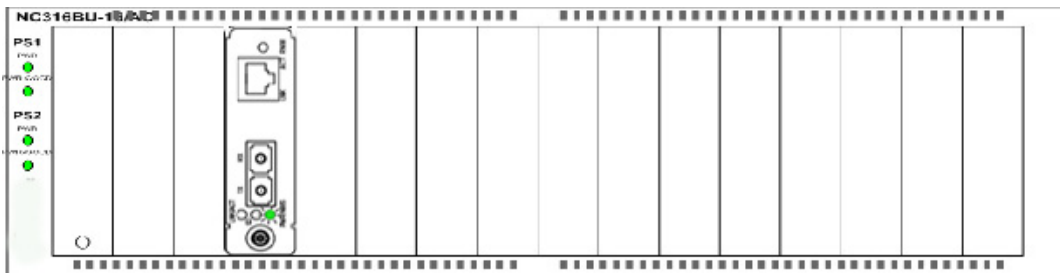

Figure 12 -- Correctly inserted Fiber Driver module in a powered chassis

Handle the module by the edges to avoid damaging any components. Use your thumb to push it securely into the chassis slot. Do not use excessive force, but make sure the module connector is fully inserted in the chassis. Secure the module by hand using the thumbscrew.

Cleaning Fibers

Fiber optic components and cables are very sensitive to dirt, dust, and mishandling. Especially in high-speed networks such as gigabit Ethernet and OC48, dirty or mistreated fiber may cause errors and signal degradation.

Prior to installation, follow the procedure below to clean fiber optic cable and transceivers.

Equipment Requirements

- Optical cleaner cartridge
- Can of compressed air

Cleaning Procedure

Blow a stream of compressed air on the fiber ends while the caps are in place.

Remove the caps, and blow the ends of the fibers again.

Follow the instructions included with the cleaning cartridge to clean the ends of the fibers.



Figure 13 -- Cleaning cartridge

Sample Fibers: Before and After Cleaning

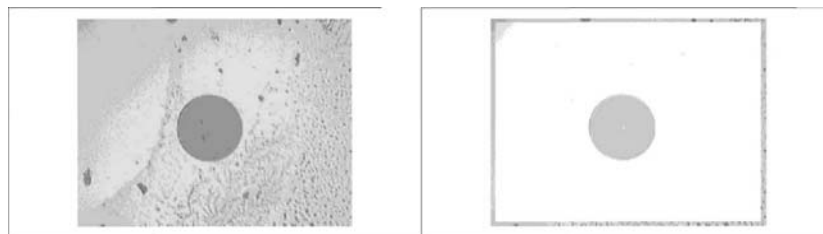

Figure 14 – Contaminated fiber and clean fiber

3.3.3 Working with SFPs

The pluggable optics modules used in the EM316xx products are extremely portable, and consequently may be easily mistreated. If SFPs are not protected against dust, remove the dust caps and clean them with 1.25 millimeter cleaners.



Figure 15 -- SFP cleaners

3.3.3.1 Cleaning SFPs

3.3.3.1.1 Requirements

SFP to be cleaned
1.25 mm cleaners

3.3.3.1.2 Procedure

- Insert the 1.25mm cleaner into the SFP
- Turn ¼ turn
- Remove the 1.25mm cleaner and discard
- Repeat the process

Do not stretch optical fibers or bend them too tightly. Install optical cables with as little fiber stress as possible.

3.3.3.2 Mylar Tab SFP Modules

The Mylar tab or nail latch on the module has a tab that you must pull in order to remove the module from a switching module port.

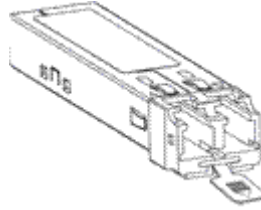

Figure 16 -- Mylar Tab on SFP Module

3.3.3.2.1 Inserting a Mylar Tab SFP Module

To insert the Mylar tab SFP module into a switching module port, line up the SFP module with the port, and slide it into place



Figure 17 -- Insertion of a Mylar Tab SFP Module

3.3.3.2.2 Removing a Mylar Tab SFP Module

To remove the SFP module from the switching module port, pull the tab gently until the SFP module disengages from the port, and then pull the SFP module out.

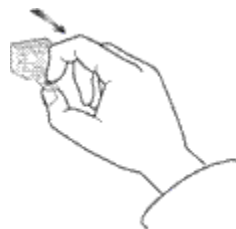

Figure 18 -- Removal of a Mylar Tab SFP Module



Caution When pulling the tab to remove the SFP module, be sure to pull in a straight outward motion. Do not twist or forcibly pull the tab because you may disconnect it from the SFP module.

3.3.3.3 Actuator/Button SFP Modules

The actuator/button SFP module has a button that you must push in order to remove the SFP module from a switching module port.

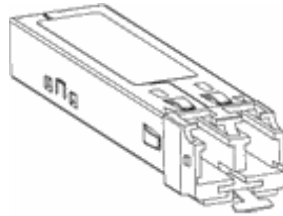

Figure 19 – Actuator/Button SFP Module

3.3.3.4 Inserting an Actuator/Button SFP Module

To insert the actuator/button SFP module into a switching module port, line up the SFP module with the port and slide it in until the actuator/button clicks into place. Be sure not to press the actuator/button as you insert the SFP module because you might inadvertently disengage the SFP module from the port.



Figure 20 -- Insertion of an Actuator/Button SFP Module

3.3.3.4.1 Removing an Actuator/Button SFP Module

Step 1 Gently press the actuator/button on the front of the SFP module until it clicks and the latch mechanism activates, releasing the SFP module from the port.

Step 2 Grasp the actuator/button between your thumb and index finger and carefully pull the SFP module from the port.

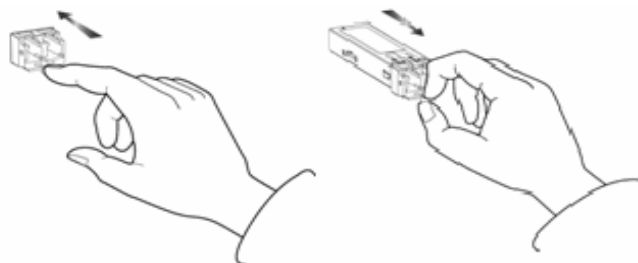

Figure 21 -- Removal of an Actuator/Button SFP Module

3.3.3.5 Bale Clasp SFP Module

The bale clasp SFP module has a bale clasp that you use to secure the SFP/XFP module in a switching module port.

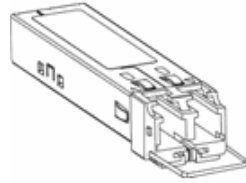

Figure 22 -- Bale Clasp SFP Module

3.3.3.5.1 Inserting a Bale Clasp SFP/XFP Module into a Switching Module Port

Step 1 Close the bale clasp in the upward direction before inserting the SFP module.

Step 2 Line up the SFP module with the port and slide it into the port.

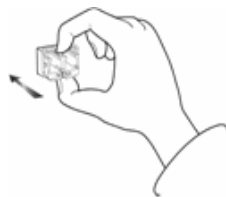

Figure 23 -- Insertion of a Bale Clasp SFP Module

3.3.3.5.2 Removing a Bale Clasp SFP Module

Step 1 Open the bale clasp on the SFP module: With your index finger, press the clasp downward as shown. If the bale clasp is obstructed and you can not use your index finger to open it, use a small, flat-blade screwdriver or other long, narrow instrument to open the bale clasp as shown.

Step 2 Grasp the SFP module between your thumb and index finger and carefully remove it from the switching module port as shown.



Open a Bale Clasp with a Flat-Blade Screwdriver if needed.

Figure 24 -- Removal of a Bale Clasp SFP Module

4 Module Management

Most Fiber Driver modules, including the EM316SW-XY, may be managed by a Fiber Driver network management (NM) module installed in the same chassis.

The EM316SW-XY module may be managed by the EM316LNXM-OT Network Management (NM) module.

The NM module installs in the same chassis as the managed modules. It provides management for the EM316SW-XY module and other compatible Fiber Driver modules resident in the chassis. Refer to specific module documentation to determine compatibility with a specific NM.

Factory settings work in most EM316SW-XY installations, but network management through an NM module is recommended for local and remote- system status monitoring. Network environments are unpredictable, and Fiber Driver network management is a critical tool for proactive administration as well as for reduced operating expenses.

The NM provides a command line interface (CLI), accessible either through a local serial port and console or from the IP network using a terminal emulation environment. Some CLI commands specific to the EM316SW-XY in a managed environment are discussed in this section. Refer to the appropriate NM documentation (EM316LNXM-OT) for further details regarding the interface and commands specific to your installation.

The network management module also provides Simple Network Management Protocol (SNMP) support to allow control through any industry standard network management system (NMS). To maximize the graphical remote management control of Fiber Driver modules, MRV offers MegaVision® Pro. It is a unique and full-featured NMS with graphical user interfaces (GUI) for all managed MRV network components including Fiber Driver. A limited version of MegaVision called “Configurator” is available for trial through the MRV website (<http://www.mrv.com>). Refer to MegaVision Pro documentation for more information on the benefits offered with the product.

4.1 Serial Console Interface

After the network management (NM) module is installed, power up the chassis and attach the serial RS-232 cable to the PC or terminal device. Configuring terminal emulation software on the PC is beyond the scope of this document. The components below may be ordered from MRV.

- Adapter (part number 350-0308 REV-B MRG/20028-2)
- Cable (part number 151-3028 REV-F AI 04/04)

The NM has at least one Ethernet port, which is typically used to connect to a Local Area Network (LAN). The factory default IP address is 192.168.14.201 with netmask 255.255.255.0, sometimes written as 192.168.14.201/24 to show the 24 bits masked for subnetting. The default gateway address is 192.168.14.1/24.

From the network, connect to the NM IP address using telnet or SSH (secure shell) to open the command line interface (CLI). Telnet services are disabled by default on the EM316LNXM-OT, but they may be enabled for additional CLI access.

The NM has an RS-232 interface that is used for serial communications to the CLI. This connection is recommended for network setup. Besides configuration simplicity, it offers the advantage of “out-of-band” management for greater network autonomy.

Configure the EM316LNXM-OT RS-232 serial parameters with the following values.

RS-232 Serial Port Parameters	<ul style="list-style-type: none">• 38400 baud• 8 data bits• 1 stop bit• no parity• no flow control
----------------------------------------------	-------------------------------------------------------------------------------------------------------------------------------------------------------

4.2 MegaVisionJ Embedded GUI Management

The EM316LNXM-OT management module includes MegaVisionJ, a built-in graphical interface to manage only the MRV chassis system controlled by the specified NM. This graphical system is accessible from any standard Java-enabled web browser that can reach the IP address assigned to the EM316LNXM-OT. MegaVisionJ allows remote management of the entire Fiber Driver chassis system and compatible modules.

4.3 EM316LNxNM-OT Command Line Interface (CLI)

The EM316LNxNM-OT provides command line interface (CLI), SNMP, and graphical administration options for a Fiber Driver chassis system. This section introduces the CLI for the Linux-based network management (EM316LNxNM-OT) module.

EM316LNxNM-OT management commands are specific to each module.

Some commands applicable to the EM316SW-XY and a managed host chassis are illustrated in this manual. The box below lists a few of the sample commands addressed in this document. Refer to the Table of Contents for a list of commands addressed here, and refer to EM316LNxNM-OT documents for more detail.

– show	– show digital-diagnostics
– show version	– show config
– show slots	– show defaults
– show x.x	– description <name>
– ?	– shutdown / no shutdown
– list	– loopback / no loopback
– lin / no lin	

Figure 25 -- EM316LNxNM-OT general commands for EM316SW-XY modules

Some of these commands apply to both slot-level and port-level contexts as described in the navigation portion of this section. Refer to EM316LNxNM-OT documentation for a more complete discussion of the Linux-based interface and available commands.

4.3.1 EM316LNXNM-OT Boot and CLI Login

The box below shows the NM boot and login to the built-in admin user account. The “banner” information that displays after the login may also be displayed from the CLI prompt with the `show version` command. The `show` command is introduced in a later section. Refer to EM316LNXNM-OT documentation for network manager and CLI configuration help.

```

U-Boot 1.0.1 (Jan 25 2005 - 11:08:25)

CPU:   MPC875ZPnn at 133 MHz: 8 kB I-Cache 8 kB D-Cache FEC1 FEC2
BOARD: MRV NM2 v3
DRAM:  (64 MB SDRAM) 64 MB
FLASH: 16.5 MB
Net:    FEC ETHERNET
Hit any key to stop autoboot:  0
## Booting image at e0000000 ...
   Image Name:   EM316LNXNM
   Image Type:   PowerPC Linux Multi-File Image (gzip compressed)
   Data Size:    7322655 Bytes =  7 MB
   Load Address: 00000000
   Entry Point:  00000000
   Contents:
   Image 0:     676629 Bytes = 660.8 kB
   Image 1:    6646011 Bytes =  6.3 MB
   Verifying Checksum ... OK
   Uncompressing Multi-File Image ... OK
   Loading Ramdisk to 03920000, end 03f768fb (6568fb)... OK

                Welcome to MRV EM316LNXNM

Reading configuration: ok

Starting up, please wait
FPGA Already Loaded.

MRV EM316LNXNM

login: admin
Password:

Please wait, initializing...now ready.
EM316LNXNM-OT v4.0 fdr 58 (Jul 25 2007 - 09:34:25).
U-Boot 1.0.1 (Jan 25 2005 - 11:08:25).
Linux kernel v2.4.26 (#1 Wed Dec 13 10:36:44 PST 2006).
EM316LNXNM (firmware 5c.13) (00:20:1a:02:48:28).
MegaVisionJ v2.34k6 - July 5, 2007 (FiberDriver v1.61j)
Copyright (c) MRV Corp. 1993-2007
You are a SUPER user!
fiberdriver#
    
```

4.3.2 CLI Navigation

The CLI uses five operational contexts: login, configuration, chassis, slot, and port. Only the login context is not considered a configuration mode. The system prompt includes a string to indicate the current operational context, as illustrated in the example below. The “#” character ends the prompt string, and a space separates the command from the prompt.

Each navigation command in the box below is bold for emphasis in print only.

```
fiberdriver# configure terminal
fiberdriver(config)# chassis 1
fiberdriver(chassis/1)# slot 1.3
fiberdriver(slot/1.3)# port 1.3.2
fiberdriver(port/1.3.2)# next
fiberdriver(port/1.3.3)# exit
fiberdriver(config)# exit
fiberdriver#
```

These contexts are not entirely hierarchical, but the three hardware-specific contexts do follow a structure that reflects the physical device relationships. The chassis contains slots (modules) which in turn contain ports.

Enter the configuration context with the “`configure terminal`” command. Any hardware context may be reached directly from the config context or any other hardware context. For example, there is no need to pass through the chassis context to reach the slot or port contexts.

The `next` command is a short-cut for navigating to the hardware context following the current context and at the same level. In the box above, the port value in the prompt increments from 2 to 3 to indicate this context change.

Operations on the larger component may sometimes also apply to the smaller components contained in the larger target device. Refer to EM316LNXM-OT documentation or use the CLI help feature “?” for more information about CLI context navigation.

4.3.3 Login Context Commands and Examples

The login context refers to the only CLI state not considered a configuration context. Commands in this context are generally for system status monitoring. Use the “?” and “list” commands at the `fiberdriver #` prompt to display the list of command line options. These help commands are shown in the slot and port command illustrations later in this section.

A few login context commands are illustrated in this section.

4.3.3.1 “?”

The following box displays the commands available in the login context of the CLI.

```

fiberdriver# ?
  configure  Enter configuration context
  cp         Copy files
  echo       Display text for scripting
  erase      Erase configuration or NVRAM
  exit       Exit current context and go down to previous context
  group      Group configuration
  list       Print command list
  logout     Logout of the system
  ls         List files
  more       Display file
  mv         Rename files
  no         Negate a command
  pager      Pause scrolling when screen is full
  ping       Send ICMP echo messages to test network connectivity
  quit       Exit current context and go down to previous context
  restart    Reboot the NM card
  rm         Remove files
  scp        Use SCP to transfer files (small config files only)
  show       Show running system information
  sleep      Pause CLI for scripting
  source     Read CLI commands from file
  ssh        Open a SSH connection
  telnet     Open a telnet connection
  terminal   Set current terminal parameters
  tftp       TFTP commands
  upgrade    Upgrade software
  who        Find out who is connected to the system
  whoami     Who am I?
  write      Write running configuration to memory or terminal
fiberdriver#
    
```

4.3.3.2 “show chassis”

The following box displays the configuration of the chassis.

```
fiberdriver# show chassis
Chassis Model      Name      Number Of Slots  Temp(C)
=====  =====  =====  =====
1         NC316BU-16  NC316BU-1  16          21

fiberdriver#
```

4.3.3.3 “show slots”

The following box displays information about the slots in the chassis.

```
fiberdriver# show slots
Slot Model          Name          Serial Number
====  =====  =====  =====
1.1  EM316LNXXNM-OT  EM316LNXXNM-OT at 1.1  00:20:1a:02:13:f2
1.3  EM316SW-XY      EM316SW-XY at 1.3      N/A

fiberdriver#
```

4.3.3.4 “show version”

The `show version` command displays revision levels for the management system components.

```
fiberdriver# show version  
EM316LNXNM-OT v4.0 fdr 58 (Jul 25 2007 - 09:34:25).  
U-Boot 1.0.1 (Jan 25 2005 - 11:08:25).  
Linux kernel v2.4.26 (#1 Wed Dec 13 10:36:44 PST 2006).  
EM316LNXNM (firmware 5c.13) (00:20:1a:02:48:28).  
MegaVisionJ v2.34k6 - July 5, 2007 (FiberDriver v1.61j)  
Copyright (c) MRV Corp. 1993-2007  
fiberdriver#
```

4.3.3.5 “show log”

The `show log` command displays log settings for the management system components.

```
fiberdriver(config)# show log  
Running Level: warning  
Nvram Level: disabled  
Trap Level: warning  
Remote Server: 0.0.0.0  
Remote Level: notice  
fiberdriver(config)#
```

4.3.3.6 “show groups”

Management access is controlled through group and user permissions. Display the current system groups and users with the commands shown below.

```
fiberdriver# show groups
System user/group configuration:
username admin password encrypted $1$kQ2rIq/$Ob8wFa2EW135XC4TnN7wJ/ class
super
username admin group all
username boss password encrypted $1$8kwjpD/$rtxpBG0AYfC7z7WxdjBuG. class
super
username boss group all
group all write 1

Your configured permissions:
Read/Write Chassis: 1
    (From Group 'all')

fiberdriver#
```

4.3.3.7 “show users”

```
fiberdriver# show users
username admin password encrypted $1$kQ2rIq/$Ob8wFa2EW135XC4TnN7wJ/ class
super
username admin group all
username boss password encrypted $1$8kwjpD/$rtxpBG0AYfC7z7WxdjBuG. class
super
username boss group all
fiberdriver#
```

4.3.3.8 “show running-config”

```
fiberdriver# show running-config
Building configuration...

Current configuration:
!
! Configuration saved on 2005/01/02 00:28:18
!
!
! Configuration written by admin!
!
! EM316LNXXNM-OT v4.0 fdr 58 (Jul 25 2007 - 09:34:25).
! U-Boot 1.0.1 (Jan 25 2005 - 11:08:25).
! Linux kernel v2.4.26 (#1 Wed Dec 13 10:36:44 PST 2006).
! EM316LNXXNM (firmware 5c.13) (00:20:1a:02:48:28).
! Copyright (c) MRV Corp. 1993-2007.
!
ip interface 192.168.14.201/24
username admin password encrypted $1$kQ2rIq/$Ob8wFa2EW135XC4TnN7wJ/
class super
username admin group all
username debug password encrypted $1$NUIVuN/$sN7t87lmW5aoZG8ggT.I30
class debug
username debug group all
group all write 2
group all write 1
snmp-server community read encrypted $1$hZyZkAl$xiJTxyGDfVb1bcAYyW9Wi1
snmp-server community write encrypted $1$wZCHI9/$6H3mce5Y15iLhtdpoXBoa1
ip interface dhcp
chassis 1 type NC316BU-16 rev 1
chassis 2 type VIRTUAL16
slot 1.1 type EM316LNXXNM-OT rev 4
slot 1.2 type EM316EFRM rev 6
slot 1.3 type EM316SW-XY rev 1
slot 1.4 type EM316F rev 12
slot 2.2 type EM316EFRM rev 6
fiberdriver#
```

The `show running-config` command displays the currently active system parameters for the management system.

4.3.3.9 “show startup-config”

The `show startup-config` command displays the contents of the **startup-config** file that are applied when the system boots. Default values are applied to any parameters not specified in this file.

```
fiberdriver# show startup-config
!
! Configuration saved on 2005/01/01 18:59:21
!
!
! Configuration written by admin!
!
! EM316LNXXNM-OT v4.0 fdr 54 (Jun  8 2007 - 15:57:38).
! U-Boot 1.0.1 (Jan 25 2005 - 11:08:25).
! Linux kernel v2.4.26 (#1 Wed Dec 13 10:36:44 PST 2006).
! EM316LNXXNM (firmware 5c.13) (00:20:1a:02:48:28).
! Copyright (c) MRV Corp. 1993-2007.
!
ip interface 192.168.14.201/24
username admin password encrypted $1$kQ2rIq/$Ob8wFa2EW135XC4TnN7wJ/ class
super
username admin group all
username debug password encrypted $1$NUIVuN/$sN7t87lmW5aoZG8ggT.I30 class
debug
username debug group all
group all write 1
group all write 2
snmp-server community read encrypted $1$hZyZkA1$xiJTxyGdfVb1bcAYyW9Wi1
snmp-server community write encrypted $1$wZCHI9/$6H3mce5Y15iLhtdpoxBoa1
ip interface dhcp
chassis 1 type NC316BU-16 rev 1
chassis 2 type VIRTUAL16
slot 1.1 type EM316LNXXNM-OT rev 4
slot 1.2 type EM316EFRM rev 6
slot 1.3 type EM316SW-XY rev 1
slot 1.4 type EM316F rev 12
slot 2.2 type EM316EFRM rev 6
fiberdriver#
```

4.3.3.10 Displaying and Saving System Parameters

Use the `write terminal` command to display the current operating parameters.

```
fiberdriver# write terminal
Building configuration...

Current configuration:
!
! Configuration saved on 2005/01/02 00:29:12
!
!
! Configuration written by admin!
!
! EM316LNxNM-OT v4.0 fdr 58 (Jul 25 2007 - 09:34:25).
! U-Boot 1.0.1 (Jan 25 2005 - 11:08:25).
! Linux kernel v2.4.26 (#1 Wed Dec 13 10:36:44 PST 2006).
! EM316LNxNM (firmware 5c.13) (00:20:1a:02:48:28).
! Copyright (c) MRV Corp. 1993-2007.
!
ip interface 192.168.14.201/24
username admin password encrypted $1$kQ2rIq/$Ob8wFa2EW135XC4TnN7wJ/ class super
username admin group all
username debug password encrypted $1$NUIVuN/$sN7t87lmW5aoZG8ggT.I30 class debug
username debug group all
group all write 2
group all write 1
snmp-server community read encrypted $1$hZyZkA1$xiJTxyGDfVblbcAYyW9Wi1
snmp-server community write encrypted $1$wZCHI9/$6H3mce5Y15iLhtdpoXBoa1
ip interface dhcp
chassis 1 type NC316BU-16 rev 1
chassis 2 type VIRTUAL16
slot 1.1 type EM316LNxNM-OT rev 4
slot 1.2 type EM316EFRM rev 6
slot 1.3 type EM316SW-XY rev 1
slot 1.4 type EM316F rev 12
slot 2.2 type EM316EFRM rev 6
fiberdriver#
```

Use the `write file` command to save the current parameters to the configuration file.

```
fiberdriver(port/1.3.2)# write file
Building configuration file...
OK, saved to startup-config
fiberdriver(port/1.3.2)#
```

4.3.4 Configuration Context

Enter "configuration" context, as shown below, to configure the system parameters.

```
fiberdriver# configure terminal
fiberdriver(config)#
```

The commands in this section are entered at the configuration context prompt. They are applied with the <CR> or <Enter> key, which is not printable.

4.3.4.1 Restoring Default Parameters

Use the `default` command to discard changes applied to the module configuration. The example below illustrates returning the entire module to the original factory defaults. Use the "?" after the `default` command or refer to EM316LNXM-OT documentation for parameters to reapply only selected default values including individual port settings.

The command below is applied in the main configuration context. The first command line in the box opens this context from the login context.

```
fiberdriver(config)# default 1 all
Restored default configuration for 1
Restored default configuration for 1.1
Restored default configuration for 1.1.1
Restored default configuration for 1.1.2
Restored default configuration for 1.1.3
Restored default configuration for 1.1.4
Restored default configuration for 1.2
Restored default configuration for 1.3
Restored default configuration for 1.3.1
Restored default configuration for 1.3.2
Restored default configuration for 1.3.3
Restored default configuration for 1.3.4
Restored default configuration for 1.4
Restored default configuration for 1.5
Restored default configuration for 1.6
Restored default configuration for 1.7
Restored default configuration for 1.8
Restored default configuration for 1.9
Restored default configuration for 1.10
Restored default configuration for 1.11
Restored default configuration for 1.12
Restored default configuration for 1.13
Restored default configuration for 1.14
Restored default configuration for 1.15
Restored default configuration for 1.16
fiberdriver(config)#
```

4.3.4.2 Configuring System Parameters

Once the mode is changed, the prompt also changes. Change the SUPER user password using the "username" command.

```
fiberdriver(config)# username admin password <new password>
```

Set the IP configuration using the "ip" command group. Set IP address and IP mask information using the following command.

```
fiberdriver(config)# ip interface 192.168.1.14/24
```

The IP address (192.168.1.14) and the 24-bit netmask (/24) are instructive examples. Use the IP address and netmask appropriate for the EM316LNXM-OT on your network. Classless Inter-Domain Routing (CIDR) notation is used to specify the address "192.168.1.14" and the address mask "24" corresponding to 255.255.255.0.

Set specific gateway information using the following command:

```
fiberdriver(config)# ip default-gateway 192.168.1.1
```

The IP information configured does not load until restarting the system or using the command:

```
ip interface update
```

Use the following command to save the configuration into permanent (non-volatile) storage:

```
fiberdriver(config)# write file
fiberdriver(config)# exit
```

The system does not automatically save configurations to permanent storage. Use the `write file` command to save a configuration before restarting the system. Now the IP configuration is complete. The default SNMP community names are "public" for read and "private" for write.

Use the `description` command to change names of the chassis, slot, and port. Use the `show` command to verify the change. Chassis names are limited to nine characters.

4.3.5 Chassis Context

Command examples in this section are applied in the chassis-level context. The box below shows the command to navigate to the chassis context from the login context.

```
fiberdriver# configure terminal
fiberdriver(config)#
fiberdriver(config)# chassis 1
fiberdriver(chassis/1)#
```

4.3.5.1 “show”

The following CLI excerpt shows a Fiber Driver chassis system with an EM316SW-XY module and an EM316LNxNM-OT network management (NM) module.

```
fiberdriver(chassis/1)# show
    Model: NC316BU-16
    Name: SOLO
    Temp(C): 24
    Temp Min(C): 5
    Temp Limit(C): 55

PS1: DC Bad  PS2: AC Good
Fan1: good  Fan2: good
Fan3: good
Chassis Traps: on  Slot Change Traps: on  Module Specific Traps: on
  Port Traps: on      Link Traps: on      Loopback Traps: on
  LIN Traps: on  Port Change Traps: on      Port Diags Traps: on

Number Of Slots: 16
Hardware Revision: 1

Slot  Model                Name                               Serial Number
====  =====
1.1   EM316LNxNM-OT           EM316LNxNM-OT at 1.1             00:20:1a:02:48:28
1.3   EM316SW-XY             EM316SW-XY at 1.3              N/A

fiberdriver(chassis/1)#
```

Use the command line “?” (help character, shown below) to display command line parameters for the show command.

4.3.5.2 Other Commands

The commands available at the chassis level are consistent in Fiber Driver environments. These general system features are beyond the scope of this document. A list of available commands in the chassis context is displayed by typing “?” or “list” at the prompt.

```
fiberdriver(chassis/1)# ?
  chassis          Configure a chassis
  default          Restore parameter(s) to defaults
  description      Set chassis name
  echo             Display text for scripting
  end              End current context and go down to initial command context
  exit             Exit current context and go down to previous context
  gen-trap        Enable trap generation for the chassis
  list            Print command list
  logout          Logout of the system
  map             Configure port map for entire current context
  next            Configure next element
  no              Negate a command
  pager           Pause scrolling when screen is full
  port            Configure a port
  previous        Configure previous element
  quit           Exit current context and go down to previous context
  show           Show basic info
  sleep          Pause CLI for scripting
  slot           Configure a slot
  temperature-limit Adjust high-temperature limit (deg. C)
  temperature-min Adjust low-temperature limit (deg. C)
  who            Find out who is connected to the system
  whoami         Who am I?
  write          Write running configuration to memory or terminal
fiberdriver(chassis/1)#
```

For a list of available commands in any context, type “?” or “list” at the prompt or refer to EM316LNXM-OT manuals.

4.3.6 Slot Context Commands and Examples

The slot-level command context interacts with specific modules mounted in the managed chassis. Command examples in this section are applied to the module in the slot designated in the prompt. The box below shows the command to navigate to the slot context from the login context.

```
fiberdriver# configure terminal  
fiberdriver(config)#  
fiberdriver(config)# slot 1.1  
fiberdriver(slot/1.1)#
```

Some sample commands are illustrated in this section.

4.3.6.1 “?”

The “?” is a special help character in the EM316LNXM-OT command line. In previous releases, the “?” character did not echo to the display when typed. Beginning in version 4.0, the “?” displays as other commands do. Results of the help request are displayed immediately to the monitor.

The box below shows the output of the “?” typed alone on the command line in the slot-level configuration context. In other contexts, the display is different to reflect the commands available from the current prompt. Navigate to each operational context and type “?” at the prompt to become familiar with these commands in your environment. Also notice the different help output in the slot-level context of a different Fiber Driver module type. The box displayed below is specific to EM316SW-XY modules.

```

fiberdriver(slot/1.3)# ?
clear-type    Clear Type, if locking types
default       Restore parameter(s) to defaults
description   Set slot name
echo          Display text for scripting
end           End current context and go down to initial command context
exit          Exit current context and go down to previous context
list          Print command list
logout        Logout of the system
next          Configure next element
no            Negate a command
pager         Pause scrolling when screen is full
port          Configure a port
previous      Configure previous element
quit         Exit current context and go down to previous context
show         Show basic info
sleep         Pause CLI for scripting
slot          Configure a slot
up            Configure parent element
who           Find out who is connected to the system
whoami        Who am I?
write         Write running configuration to memory or terminal
fiberdriver(slot/1.3)#

```

The “?” may also be used in two ways after a command typed at the prompt in any context. When typed immediately after a command line entry with no space separating it from the command, the “?” displays a list of commands that match the preceding string and a description of each matching command function. When a space separates the command string from the “?”, the display shows the first matching command and a list of the options for the next required parameter on the command line.

Read more about the “?” help character in the EM316LNXM-OT User Guide. There is no substitution for practicing the command to become familiar with its behavior.

4.3.6.2 “list”

The `list` command displays all the full command options (including applicable command line arguments) available in the current context.

```
fiberdriver(slot/1.1)# list
clear-type
default all
default description
default me
description .LINE
echo
echo .LINE
end
exit
list
logout
next
no description
no pager
pager
port (PORT-NUM|PORT)
previous
quit
show
show config
show defaults
show digital-diagnostics
show running-config
show statistics
sleep <0-10>
slot SLOT
up
who
who am i
whoami
write file
write terminal
fiberdriver(slot/1.1)#
```

4.3.6.3 “show”

The “show” command displays management and system information related to the EM316LNxNM-OT management module, the hosting chassis, other modules in the chassis, and ports available within the managed system. The arguments (parameters) following the show command and the operational context displayed by the system prompt control the many functions available through this command.

The next box displays the CLI help for the show command in the slot-level context of the EM316SW-XY modules. The first command (shown in bold) is “show?” and the second command (also in bold) is “show ?”. The subtle difference between the two commands is the space separating the command from the “?” in the second command.

```

fiberdriver(slot/1.4)# show?
  show Show basic info
fiberdriver(slot/1.4)# show ?
<cr> Show basic info
config Show administrative configuration for this object
defaults Show default configuration for this object
digital-diagnostics Show Digital Diagnostics summary
redundancy Show slot redundancy info
running-config Current operating configuration
statistics Show port info
fiberdriver(slot/1.4)# show

```

The box below illustrates the show command applied with no arguments in the slot-level context of an EM316SW-XY module.

```

fiberdriver(slot/1.3)# show
  Slot: 1.3
  Model: EM316SW-XY
  Name: EM316SW-XY at 1.3
Hardware Revision: 1, FPGA 0x68

Sw Configurable: yes      Operation Type: redundant
Redundancy: enabled

Number Of Ports: 4
Port  Enable  Link      LIN      Speed    DDiags  WL(nm)  Name
=====
1.3.1 enable  no Signal disable  10 Mbps  N/A     N/A     RJ-45 at 1.3.1
1.3.2 enable  no Signal disable  100 Mbps Alarm    850     SFP at 1.3.2
1.3.3 enable  no Signal disable  100 Mbps Alarm    850     SFP at 1.3.3
1.3.4 disable no Signal N/A      N/A      N/A     N/A     RJ-45 at 1.3.4

fiberdriver(slot/1.3)#

```

Display Digital Diagnostic statistics for the SFP ports with the command shown below.

```

fiberdriver(slot/1.5)# show digital-diagnostics
Port   DDiags  Temp(C)  Supply(V)  TxPower(dBm)  RxPower(dBm)  Bias(mA)
=====
1.5.2  Alarm   42       3.308      -6.144        -23.553       4.248
1.5.3  Alarm   47       3.282      -5.669        -26.739       5.728

fiberdriver(slot/1.5)#

```

The boxes below illustrate two common parameters used with the `show` command.

Default settings are listed in the `show defaults` command output. These parameters reflect the module boot configuration which is determined by DIP switches and firmware programming. All lines in this display begin with “!” to indicate that they are comments for information only.

```

fiberdriver(slot/1.3)# show defaults
slot 1.3
! description EM316SW-XY at 1.3
fiberdriver(slot/1.3)#

```

The `show config` command displays the active environment settings currently in the operational context. The lines beginning with “!” are comments added for clarity in the CLI display only. The comment lines ending with “:” are headings that describe the settings listed in this display.

```

fiberdriver(slot/1.3)# show config
slot 1.3
! Configured parameters that override defaults:
! Configured parameters that match defaults:
! Parameters that will follow defaults:
! description EM316 SW-XY at 1.3
fiberdriver(slot/1.3)#

```

The default parameter values are constant for each module, but can change to reflect DIP switch settings. Changes to these parameter values are reflected in the `show config` command output. Restoring the default values returns the module to its original operating state. Preserve changes made to the configuration for use in future CLI sessions and beyond a reboot by writing them to the **startup-config** file as described later in this section.

Each module may be given a descriptive name with the command below. The `show` command follows with the new name line in bold font. Each new slot name may also be displayed with individual `show` commands in each slot context.

```

fiberdriver(slot/1.3)# description MY-SW-XY
fiberdriver(slot/1.3)# up
fiberdriver(chassis/1)# show
    Model: NC316BU-16
    Name: NC316BU-1
    Temp(C): 25
    Temp Min(C): 5
    Temp Limit(C): 55

PS1: DC Bad  PS2: AC Good
Fan1: good  Fan2: good
Fan3: good
Chassis Traps: on  Slot Change Traps: on  Module Specific Traps: on
  Port Traps: on      Link Traps: on      Loopback Traps: on
  LIN Traps: on  Port Change Traps: on      Port Diags Traps: on

Number Of Slots: 16
Hardware Revision: 1

Slot  Model                Name                Serial Number
====  =====
1.2   EM316LNXXNM-OT          EM316LNXXNM-OT at 1.2  00:20:1a:02:48:28
1.3   EM316SW-XY            MY-SW-XY              N/A

fiberdriver(chassis/1)#

```

4.3.7 Port Context Commands and Examples

Command examples in this section are applied in the port-level context. The box below shows the command to navigate to a specific port context from the login context.

```
fiberdriver# configure terminal
fiberdriver(config)# port 1.3.1
fiberdriver(port/1.3.1)#
```

4.3.7.1 “?”

The “?” command, used alone on the command line, lists the commands available in the current operational context.

The “?” may also be used in two ways following a command word typed at the prompt in any context. When typed immediately after a command line entry with no space separating it from the command, the “?” displays a list of commands that match the preceding string and a description of each matching command function. When a space separates the command string from the “?”, the display shows the first matching command and a list of the options for the next required parameter on the command line.

Read more about the “?” help character in the EM316LNxNM-OT User Guide. There is no substitution for practicing the command to become familiar with its behavior.

The box below shows the output of the “?” typed alone on the command line in the port-level configuration context. The box below is specific to the RJ-45 copper ports (P1 and P4) of the EM316SW-XY modules.

```
fiberdriver(port/1.3.1)# ?
  auto-neg-adv      Adjust auto-negotiation advertisement
  auto-negotiation Enable auto-negotiation
  default           Restore parameter(s) to defaults
  description       Set port name
  duplex            Adjust port duplex setting
  echo             Display text for scripting
  end              End current context and go down to initial command context
  exit             Exit current context and go down to previous context
  list             Print command list
  logout           Logout of the system
  mdi-pinout       Adjust MDI/MDI-X auto-sense
  next            Configure next element
  no              Negate a command
  pager           Pause scrolling when screen is full
  port            Configure a port
  previous        Configure previous element
  protocol        Set protocol
  quit           Exit current context and go down to previous context
  rm-chassis      Set remote chassis connectivity information
  rm-port        Set remote port connectivity information
  rm-slot        Set remote slot connectivity information
  show           Show basic info
  shutdown       Disable the port
  sleep          Pause CLI for scripting
  speed          Adjust port speed
  up            Configure parent element
  who           Find out who is connected to the system
  whoami        Who am I?
  write          Write running configuration to memory or terminal
fiberdriver(port/1.3.1)#
```

The commands listed by the help (“?”) command may be different depending upon the specific port context displayed.

The box below is specific to the SFP ports (P2 and P3) of the EM316SW-XY modules in **NON-REDUNDANT** operational modes including the **DEFAULT** configuration. Notice the differences in the command list that reflect the capabilities of the target port.

```

fiberdriver(port/1.3.2)# ?
  default      Restore parameter(s) to defaults
  description  Set port name
  echo         Display text for scripting
  end          End current context and go down to initial command context
  exit         Exit current context and go down to previous context
  list         Print command list
  logout       Logout of the system
  loopback    Enable Loopback
  next         Configure next element
  no           Negate a command
  pager        Pause scrolling when screen is full
  port         Configure a port
  previous     Configure previous element
  protocol     Set protocol
  quit         Exit current context and go down to previous context
  rm-chassis   Set remote chassis connectivity information
  rm-port      Set remote port connectivity information
  rm-slot      Set remote slot connectivity information
  show         Show basic info
  shutdown    Disable the port
  sleep        Pause CLI for scripting
  up           Configure parent element
  who          Find out who is connected to the system
  whoami       Who am I?
  write        Write running configuration to memory or terminal
fiberdriver(port/1.3.2)#

```

The commands listed by the help (“?”) command may be different depending upon the specific port context displayed.

The box below is specific to the SFP ports (P2 and P3) of the EM316SW-XY modules in **REDUNDANT** mode.

Notice the differences in the command list from the same port in a non-redundant mode.

- shutdown is no longer available
- select-link is available only in redundant mode
- lin is available

```
fiberdriver(port/1.3.2)# ?
default      Restore parameter(s) to defaults
description  Set port name
echo         Display text for scripting
end          End current context and go down to initial command context
exit         Exit current context and go down to previous context
lin         Enable LIN
list         Print command list
logout       Logout of the system
loopback     Enable Loopback
next         Configure next element
no           Negate a command
pager        Pause scrolling when screen is full
port         Configure a port
previous     Configure previous element
protocol     Set protocol
quit         Exit current context and go down to previous context
rm-chassis   Set remote chassis connectivity information
rm-port      Set remote port connectivity information
rm-slot      Set remote slot connectivity information
select-link Select whether channel carries data
show         Show basic info
sleep        Pause CLI for scripting
up           Configure parent element
who          Find out who is connected to the system
whoami       Who am I?
write        Write running configuration to memory or terminal
fiberdriver(port/1.3.2)#
```

4.3.7.2 “list”

The `list` command displays all the full command options (including applicable command line arguments) available in the current context.

4.3.7.3 “show”

The `show` command displays management and system information related to the EM316LNXM-OT management module, the hosting chassis, other modules in the chassis, and ports available within the managed system. The arguments (parameters) following the `show` command and the operational context displayed by the system prompt control the many functions available through this command.

The box below illustrates the `show` command. The help “?” is applied first, then the command is used with no arguments in the port context of a copper port in an EM316SW-XY module.

```

fiberdriver(port/1.3.1)# show
  Port: 1.3.1
  Name: RJ-45 at 1.3.1
  Protocol: Ethernet
  Rate: 10Base-T 10 Mbps

  Enable: enable           LIN: disable
  Link: no Signal         Speed: 10 Mbps
                           MDI Pinout: mdi
                           Duplex: half   MDI Pinout desired: auto Sense
                           Auto Neg: on
                           Adv 10Base-T: on
                           Adv 100Base-Tx: on

  Connector: RJ45  Medium: twisted Pair
  Rx Activity: off  Tx Activity: off

fiberdriver(port/1.3.1)#
    
```

The CLI help for the `show` command is identical in the port-level context and the slot-level contexts. Refer to the Slot-Level Commands section for “`show?`” and “`show ?`” information.

The box below illustrates the `show` command with no arguments in the port context of an SFP port with an optical transceiver in an EM316SW-XY module.

```
fiberdriver(port/1.3.2)# show
  Port: 1.3.2
  Name: SFP at 1.3.2
Part #/Rev: SFP-DGD-SX/A
  Protocol: Ethernet
    Rate: 100Base-Tx 100 Mbps

  Enable: enable          LIN: disable
  Link: no Signal        Speed: 100 Mbps
                          Nom. BR: 2100
                          Duplex: full

Revertive: no

  Loopback: off
Serial Number: U982S8B
  Vendor Info: MRV

Connector: fo LC  Medium: multi Mode
Wavelength(nm): 850
  TxPower(dBm): -4.579  RxPower(dBm): -35.228  Bias(mA): 9.251
    DDiags: Alarm      Temp(C): 33      Supply(V): 3.305

Rx Activity: off  Tx Activity: off
Alarm Cause: Rx Power Too Low Alarm

fiberdriver(port/1.3.2)#
```

4.3.7.4 “description”

As with a module at the slot level, a descriptive name may be applied to each port. An example of the `description` command at the port level is shown below.

```
fiberdriver(port/1.3.1)# description SWXY-port1
fiberdriver(port/1.3.1)# show
  Port: 1.3.1
  Name: SWXY-port1
  Protocol: Ethernet
  Rate: 10Base-T 10 Mbps

  Enable: enable                LIN: disable
  Link: no Signal                Speed: 10 Mbps

                                Duplex: half      MDI Pinout: mdi
                                Auto Neg: on       MDI Pinout desired: auto Sense
                                Adv 10Base-T: on
                                Adv 100Base-Tx: on

  Connector: RJ45  Medium: twisted Pair
  Rx Activity: off  Tx Activity: off

fiberdriver(port/1.3.1)#
```

4.3.7.5 “show defaults”

Default settings are listed in the `show defaults` command output. These parameters reflect the module boot configuration which is determined by DIP switches and firmware programming. All lines in this display begin with “!” to indicate that they are comments for information only.

```
fiberdriver(port/1.3.1)# show defaults
port 1.3.1
! auto-negotiation
! duplex full
! speed 100
! no shutdown
! description RJ-45 at 1.3.1
! rm-chassis 0
! rm-slot 0
! rm-port 0
! ! auto-neg-adv 0x0f:
! auto-neg-adv all
! mdi-pinout auto-sense
fiberdriver(port/1.3.1)#
```

4.3.7.6 “show config”

The `show config` command displays the active environment settings currently in the operational context. The lines beginning with “!” are comments added for clarity in the CLI display only. The comment lines ending with “:” are headings that describe the settings listed in this display.

```

fiberdriver(port/1.3.1)# show config
port 1.3.1
! Configured parameters that override defaults:
! Configured parameters that match defaults:
! Parameters that will follow defaults:
! auto-negotiation
! duplex full
! speed 100
! no shutdown
! description RJ-45 at 1.3.1
! rm-chassis 0
! rm-slot 0
! rm-port 0
! ! auto-neg-adv 0x0f:
! auto-neg-adv all
! mdi-pinout auto-sense
fiberdriver(port/1.3.1)#
    
```

The default parameter values are constant for each module, but can change to reflect DIP switch settings. Changes to these parameter values are reflected in the `show config` command output. Restoring the default values returns the module to its original operating state. Preserve changes made to the configuration for use in future CLI sessions and beyond a reboot by writing them to the **startup-config** file as described later in this section.

4.3.7.7 “shutdown” and “no shutdown”

The `shutdown` commands enable and disable the transmitter of the target port. SFP ports in redundant mode may not be disabled, so the command is not available in the corresponding mode and context.

```

fiberdriver(port/1.3.1)# shutdown
fiberdriver(port/1.3.1)# no fdrd[60]|TRAP| warn|Jan 01 19:25:25
Port 1.3.1 Disabled, Chassis Name: NC316BU-16 Slot
Name: EM316SW-XY at 1.3 Port Name: RJ-45 at 1.3.1

fiberdriver(port/1.3.1)#
fiberdriver(port/1.3.1)# no shutdown
fiberdriver(port/1.3.1)# fdrd[60]|TRAP| warn|Jan 01 19:25:37
Port 1.3.1 Enabled, Chassis Name: NC316BU-16 Slot Nam
e: EM316SW-XY at 1.3 Port Name: RJ-45 at 1.3.1

fiberdriver(port/1.3.1)#
    
```

4.3.7.8 “lin”

The `lin` commands enable and disable the Lin Integrity Notification function on the target port.

```

fiberdriver(port/1.3.1)# lin
  fdrd[60]|CORE|   warn|Jan 01 19:25:50 1.3.4: Auto-adjusted PortLIN -> enable Ok
  fdrd[60]|TRAP|   warn|Jan 01 19:25:52 Port 1.3.1 LIN On, Chassis Name: NC316BU-16
Slot Name: EM316SW-XY at 1.3 Port Name: RJ-45 at 1.3.1
  fdrd[60]|TRAP|   warn|Jan 01 19:25:52 Port 1.3.4 LIN On, Chassis Name: NC316BU-16
Slot Name: EM316SW-XY at 1.3 PortName: RJ-45 at 1.3.4

fiberdriver(port/1.3.1)#
fiberdriver(port/1.3.1)# no lin
  fdrd[60]|CORE|   warn|Jan 01 19:26:01 1.3.4: Auto-adjusted PortLIN -> disable Ok
  fdrd[60]|TRAP|   warn|Jan 01 19:26:04 Port 1.3.1 LIN Off, Chassis Name: NC316BU-16
Slot Name: EM316SW-XY at 1.3 Port Name: RJ-45 at 1.3.1
  fdrd[60]|TRAP|   warn|Jan 01 19:26:04 Port 1.3.4 LIN Off, Chassis Name: NC316BU-16
Slot Name: EM316SW-XY at 1.3 Port Name: RJ-45 at 1.3.4

fiberdriver(port/1.3.1)#
    
```

In redundant-mode, changing LIN on any port, P1, P2, or P3, automatically adjusts LIN on the remaining ports. Since port P4 is disabled, no message displays for that port.

```

fiberdriver(port/1.3.3)# lin
  fdrd[60]|CORE|   warn|Jan 02 18:38:01 1.3.1: Auto-adjusted PortLIN -> enable Ok
  fdrd[60]|CORE|   warn|Jan 02 18:38:01 1.3.2: Auto-adjusted PortLIN -> enable Ok
  fdrd[60]|TRAP|   warn|Jan 02 18:38:04 Port 1.3.1 LIN On, Chassis Name: NC316BU-16
Slot Name: EM316SW-XY at 1.3 Port Name: RJ-45 at 1.3.1
  fdrd[60]|TRAP|   warn|Jan 02 18:38:04 Port 1.3.2 LIN On, Chassis Name: NC316BU-16
Slot Name: EM316SW-XY at 1.3 PortName: SFP at 1.3.2
  fdrd[60]|TRAP|   warn|Jan 02 18:38:04 Port 1.3.3 LIN On, Chassis Name: NC316BU-16
Slot Name: EM316SW-XY at 1.3 PortName: SFP at 1.3.3

fiberdriver(port/1.3.3)# no lin
  fdrd[60]|CORE|   warn|Jan 02 18:38:09 1.3.1: Auto-adjusted PortLIN -> disable Ok
  fdrd[60]|CORE|   warn|Jan 02 18:38:09 1.3.2: Auto-adjusted PortLIN -> disable Ok
  fdrd[60]|TRAP|   warn|Jan 02 18:38:12 Port 1.3.1 LIN Off, Chassis Name: NC316BU-16
Slot Name: EM316SW-XY at 1.3 Port Name: RJ-45 at 1.3.1
  fdrd[60]|TRAP|   warn|Jan 02 18:38:12 Port 1.3.2 LIN Off, Chassis Name: NC316BU-16
Slot Name: EM316SW-XY at 1.3 Port Name: SFP at 1.3.2
  fdrd[60]|TRAP|   warn|Jan 02 18:38:12 Port 1.3.3 LIN Off, Chassis Name: NC316BU-16
Slot Name: EM316SW-XY at 1.3 Port Name: SFP at 1.3.3

fiberdriver(port/1.3.3)#
    
```

4.3.8 RJ-45 Port Commands

The commands in this section are specific to the RJ-45 Ethernet (copper) ports P1 and P4 on the EM316SW-XY module.

4.3.8.1 “auto-neg-adv”

This command sets the data rates displayed as options in auto-negotiation.

```
fiberdriver(port/1.3.1)# auto-neg-adv?
  auto-neg-adv  Adjust auto-negotiation advertisement
fiberdriver(port/1.3.1)# auto-neg-adv ?
  10            Advertise 10Base-T
  100           Advertise 100Base-Tx
  1000          Advertise 1000Base-T
  flow-control  Advertise flow control
  all           Advertise all capabilities
  full          Advertise full duplex only for all speeds
  half          Advertise half duplex only for all speeds
  hex           Advertise using hex format (see MIB descr. for
help)
fiberdriver(port/1.3.1)# auto-neg-adv all
fiberdriver(port/1.3.1)#
```

4.3.8.2 “auto-negotiation”

This command sets auto-negotiation mode on the target port.

```
fiberdriver(port/1.3.1)# auto-negotiation?
  auto-negotiation  Enable auto-negotiation
fiberdriver(port/1.3.1)# auto-negotiation ?
  <cr>
fiberdriver(port/1.3.1)# auto-negotiation
  fdrd[60]|CORE|    warn|Jan 01 22:35:34 1.3.1: Auto-adjusted
PortMDIPinoutAdmin -> removed Ok
  fdrd[60]|CORE|    warn|Jan 01 22:35:34 1.3.1: Auto-adjusted
PortDuplex -> removed Ok
  fdrd[60]|CORE|    warn|Jan 01 22:35:34 1.3.1: Auto-adjusted
PortSpeed -> removed Ok
fiberdriver(port/1.3.1)#
```

4.3.8.3 “mdi-pinout”

This command sets the mdi/mdix pinout for the target port.

```
fiberdriver(port/1.3.1)# mdi-pinout?
  mdi-pinout  Adjust MDI/MDI-X auto-sense
fiberdriver(port/1.3.1)# mdi-pinout ?
  auto-sense  Autodetect MDI/MDI-X
  mdix        MDI-X
fiberdriver(port/1.3.1)# mdi-pinout auto-sense
  fdrd[60]|CORE| warn|Jan 01 21:55:54 1.3.1: Auto-adjusted
PortAutoNegotiation -> off Ok
  fdrd[60]|CORE| warn|Jan 01 21:55:54 1.3.1: Auto-adjusted
PortDuplex -> half Ok
  fdrd[60]|CORE| warn|Jan 01 21:55:54 1.3.1: Auto-adjusted
PortSpeed -> 10 Mbps Ok
fiberdriver(port/1.3.1)#
```

4.3.8.4 “duplex”

This command sets the duplex mode on the target port.

```
fiberdriver(port/1.3.1)# duplex?
  duplex  Adjust port duplex setting
fiberdriver(port/1.3.1)# duplex ?
  full   Set to full duplex
  half   Set to half duplex
fiberdriver(port/1.3.1)# duplex full
fiberdriver(port/1.3.1)#
```

4.3.8.5 “speed”

This command sets the data rates for the target port.

```
fiberdriver(port/1.3.1)# speed?
  speed  Adjust port speed
fiberdriver(port/1.3.1)# speed ?
  10    Set to 10Mbps
  100   Set to 100Mbps
fiberdriver(port/1.3.1)# speed 100
fiberdriver(port/1.3.1)#
```

4.3.9 SFP Port Commands

The following commands are specific to the SFP ports on the EM316SW-XY module.

4.3.9.1 “loopback”

This command activates the loopback function on the target port.

```

fiberdriver(port/1.3.2)# loopback
fiberdriver(port/1.3.2)#      fdrd[60]|TRAP|      warn|Jan 01 21:30:07 Port 1.3.2
Loopback On, Chassis Name: NC316BU-16 Slot Name: EM316SW-XY at 1.3 Port Name: SFP at
1.3.2

fiberdriver(port/1.3.2)#
fiberdriver(port/1.3.2)# no loopback
fiberdriver(port/1.3.2)#      fdrd[60]|TRAP|      warn|Jan 01 21:30:22 Port 1.3.2
Loopback Off, Chassis Name: NC316BU-16 Slot Name: EM316SW-XY at 1.3 Port Name: SFP
at 1.3.2

fiberdriver(port/1.3.2)#
    
```

4.3.9.2 “lin”

This command activates or deactivates the Link Integrity Notification function.

```

fiberdriver(port/1.3.2)# lin
      fdrd[60]|CORE|      warn|Jan 01 21:30:33 1.3.1: Auto-adjusted PortLIN -> enable Ok
      fdrd[60]|CORE|      warn|Jan 01 21:30:33 1.3.3: Auto-adjusted PortLIN -> enable Ok
fiberdriver(port/1.3.2)#      fdrd[60]|TRAP|      warn|Jan 01 21:30:34 Port 1.3.1 LIN
On, Chassis Name: NC316BU-16 Slot Name: EM316SW-XY at 1.3 Port Name: RJ-45 at 1.3.1
      fdrd[60]|TRAP|      warn|Jan 01 21:30:34 Port 1.3.2 LIN On, Chassis Name: NC316BU-
16 Slot Name: EM316SW-XY at 1.3 PortName: SFP at 1.3.2
      fdrd[60]|TRAP|      warn|Jan 01 21:30:34 Port 1.3.3 LIN On, Chassis Name: NC316BU-
16 Slot Name: EM316SW-XY at 1.3 PortName: SFP at 1.3.3

fiberdriver(port/1.3.2)#
fiberdriver(port/1.3.2)# no lin
      fdrd[60]|CORE|      warn|Jan 01 21:30:42 1.3.1: Auto-adjusted PortLIN -> disable Ok
      fdrd[60]|CORE|      warn|Jan 01 21:30:42 1.3.3: Auto-adjusted PortLIN -> disable Ok
fiberdriver(port/1.3.2)#      fdrd[60]|TRAP|      warn|Jan 01 21:30:46 Port 1.3.1 LIN
Off, Chassis Name: NC316BU-16 Slot Name: EM316SW-XY at 1.3 Port Name: RJ-45 at 1.3.1
      fdrd[60]|TRAP|      warn|Jan 01 21:30:46 Port 1.3.2 LIN Off, Chassis Name: NC316BU-
16 Slot Name: EM316SW-XY at 1.3 Port Name: SFP at 1.3.2
      fdrd[60]|TRAP|      warn|Jan 01 21:30:46 Port 1.3.3 LIN Off, Chassis Name: NC316BU-
16 Slot Name: EM316SW-XY at 1.3 Port Name: SFP at 1.3.3

fiberdriver(port/1.3.2)#
    
```

4.3.9.3 “select-link”

In Redundant Link mode, the “select link” command attempts to activate the target redundant port, P2 or P3. If the selected port does not have an available link, then the other redundant port is tried.

The module selects the first established SFP interface link, port P2 or P3, as the primary link. The port not selected becomes the secondary (redundant) link which activates if the primary link fails.

```
fiberdriver(port/1.3.2)# select-link?
  select-link  Select whether channel carries data
fiberdriver(port/1.3.2)# select-link ?
  active      Attempt to make this port active
  standby     Attempt to make this port standby
fiberdriver(port/1.3.2)# select-link active
fiberdriver(port/1.3.2)#
```

4.4 Configuration Examples

Each operational mode is represented below with the “show” command.

4.4.1 Repeater Mode

```
MODE1    ON
MODE0    ON
```

In this mode, the module acts as a pair of repeaters.

- Fiber Optic Repeater between the two 100Base-FX SFP based interfaces
- Copper Repeater between the two 10/100 Base-TX interfaces

```
fiberdriver# show 1.3
      Slot: 1.3
      Model: EM316SW-XY
      Name: EM316SW-XY at 1.3
Hardware Revision: 1, FPGA 0x68

Sw Configurable: yes  Operation Type: repeater

Number Of Ports: 4
Port   Enable  Link      LIN      Speed    DDiags  WL(nm)  Name
=====
1.3.1  enable  no Signal  disable  10 Mbps  N/A     N/A     RJ-45 at 1.3.1
1.3.2  enable  no Signal  disable  100 Mbps Ok      1590    SFP at 1.3.2
1.3.3  enable  no Signal  disable  100 Mbps Ok      1590    SFP at 1.3.3
1.3.4  enable  no Signal  disable  10 Mbps  N/A     N/A     RJ-45 at 1.3.4

fiberdriver#
```

In Dual Repeater mode, copper ports P1 and P4 and paired and SFP ports P2 and P3 are paired. Only the copper port pair is shown in this example.

```
fiberdriver(config)# port 1.3.1
fiberdriver(port/1.3.1)# no lin
  fdrd[58]|TRAP|    warn|17:11:43 1978 Port 1.3.1 LIN Off
  fdrd[58]|TRAP|    warn|17:11:44 1978 Port 1.3.4 LIN Off

fiberdriver(port/1.3.4)# lin
  fdrd[58]|TRAP|    warn|17:14:37 1978 Port 1.3.1 LIN On
  fdrd[58]|TRAP|    warn|17:14:38 1978 Port 1.3.4 LIN On

fiberdriver(port/1.3.4)#
```

```
fiberdriver# show 1.3.1
  Port: 1.3.1
  Name: RJ-45 at 1.3.1
  Protocol: Ethernet
  Rate: 10Base-T 10 Mbps

  Enable: enable          LIN: disable
  Link: no Signal        Speed: 10 Mbps

                          Duplex: half      MDI Pinout: mdi
                          Auto Neg: on      MDI Pinout desired: auto Sense
                          Adv 10Base-T: on
                          Adv 100Base-Tx: on

  Connector: RJ45  Medium: twisted Pair
  Rx Activity: off  Tx Activity: off

fiberdriver#

fiberdriver# show 1.3.4
  Port: 1.3.4
  Name: RJ-45 at 1.3.4
  Protocol: Ethernet
  Rate: 10Base-T 10 Mbps

  Enable: enable          LIN: disable
  Link: no Signal        Speed: 10 Mbps

                          Duplex: half      MDI Pinout: mdi
                          Auto Neg: on      MDI Pinout desired: auto Sense
                          Adv 10Base-T: on
                          Adv 100Base-Tx: on

  Connector: RJ45  Medium: twisted Pair
  Rx Activity: off  Tx Activity: off

fiberdriver#
```

4.4.2 Converter Mode

MODE1 ON
MODE0 OFF

In Converter mode, ports P1 and P2 are paired and ports P3 and P4 are paired. Each pair links a copper port to an SFP port, which will generally have an optical SFP transceiver installed to convert between media.

```
fiberdriver# show 1.3
      Slot: 1.3
      Model: EM316SW-XY
      Name: EM316SW-XY at 1.3
Hardware Revision: 1, FPGA 0x68

Sw Configurable: yes  Operation Type: converter

Number Of Ports: 4
Port   Enable  Link      LIN      Speed    DDiags   WL(nm)   Name
=====
1.3.1  enable  no Signal  disable  10 Mbps  N/A      N/A      RJ-45 at 1.3.1
1.3.2  enable  no Signal  disable  100 Mbps Ok       1590     SFP at 1.3.2
1.3.3  enable  no Signal  disable  100 Mbps Ok       1590     SFP at 1.3.3
1.3.4  enable  no Signal  disable  10 Mbps  N/A      N/A      RJ-45 at 1.3.4

fiberdriver#
```

```
fiberdriver# show 1.3.1
  Port: 1.3.1
  Name: RJ-45 at 1.3.1
  Protocol: Ethernet
  Rate: 10Base-T 10 Mbps

  Enable: enable          LIN: disable
  Link: no Signal        Speed: 10 Mbps

                          Duplex: half      MDI Pinout: mdi
                          Auto Neg: on      MDI Pinout desired: auto Sense
                          Adv 10Base-T: on
                          Adv 100Base-Tx: on

  Connector: RJ45  Medium: twisted Pair
  Rx Activity: off  Tx Activity: off

fiberdriver#
```

```
fiberdriver# show 1.3.2
  Port: 1.3.2
  Name: SFP at 1.3.2
  Part #/Rev: SFP1250ZXCWDM/1.1
  Protocol: Ethernet
  Rate: 100Base-Tx 100 Mbps

  Enable: enable          LIN: disable
  Link: no Signal        Speed: 100 Mbps
                          Nom. BR: 1300
                          Duplex: full

  Revertive: no

  Loopback: off
  Serial Number: 33BE125099
  Vendor Info: LUMINENT

  Connector: fo LC  Medium: single Mode
  Wavelength(nm): 1590
  TxPower(dBm): 3.181  RxPower(dBm): -Inf  Bias(mA): 33.257
  DDiags: Ok          Temp(C): 43      Supply(V): 3.266

  Rx Activity: off  Tx Activity: off

fiberdriver#
```

```
fiberdriver# show 1.3.3
  Port: 1.3.3
  Name: SFP at 1.3.3
Part #/Rev: SFP-GDCWXD-59/B
  Protocol: Ethernet
  Rate: 100Base-Tx 100 Mbps

  Enable: enable          LIN: disable
  Link: no Signal        Speed: 100 Mbps
                          Nom. BR: 1300
                          Duplex: full

Revertive: no

  Loopback: off
Serial Number: 480AC7353S
  Vendor Info: MRV COMM, INC.

Connector: fo LC  Medium: single Mode
Wavelength(nm): 1590
  TxPower(dBm): -3.92  RxPower(dBm): -43.23  Bias(mA): 24.497
  DDiags: Ok          Temp(C): 41          Supply(V): 3.271

Rx Activity: off  Tx Activity: off

fiberdriver#
```

```
fiberdriver# show 1.3.4
  Port: 1.3.4
  Name: RJ-45 at 1.3.4
Protocol: Ethernet
  Rate: 10Base-T 10 Mbps

Enable: enable          LIN: disable
Link: no Signal        Speed: 10 Mbps
                          Duplex: half
                          Auto Neg: on
                          Adv 10Base-T: on
                          Adv 100Base-Tx: on
                          MDI Pinout: mdix
                          MDI Pinout desired: auto Sense

Connector: RJ45  Medium: twisted Pair
Rx Activity: off  Tx Activity: off

fiberdriver#
```

4.4.3 Redundant Mode

MODE1 **OFF**
MODE0 **ON**

```
iberdriver# show 1.3
      Slot: 1.3
      Model: EM316SW-XY
      Name: EM316SW-XY at 1.3
Hardware Revision: 1, FPGA 0x68

Sw Configurable: yes      Operation Type: redundant
Redundancy: enabled

Number Of Ports: 4
Port   Enable   Link      LIN      Speed    DDiags   WL(nm)   Name
=====
1.3.1  enable   link      enable   10 Mbps  N/A      N/A      RJ-45 at 1.3.1
1.3.2  enable   link      enable   100 Mbps Ok       1590     SFP at 1.3.2
1.3.3  enable   link      enable   100 Mbps Ok       1590     SFP at 1.3.3
1.3.4  disable no Signal N/A      N/A      N/A      N/A      RJ-45 at 1.3.4
```

4.4.4 Switching Mode

MODE1 OFF
MODE0 OFF

```

fiberdriver# show 1.3
      Slot: 1.3
      Model: EM316SW-XY
      Name: EM316SW-XY at 1.3
Hardware Revision: 1, FPGA 0x68

Sw Configurable: yes  Operation Type: switch

Number Of Ports: 4
Port   Enable  Link           Speed          DDiags  WL(nm)  Name
=====
1.3.1  enable  link           10 Mbps        N/A     N/A     RJ-45 at 1.3.1
1.3.2  enable  link           100 Mbps       Ok       1590    SFP at 1.3.2
1.3.3  enable  link           100 Mbps       Ok       1590    SFP at 1.3.3
1.3.4  enable  no Signal      10 Mbps        N/A     N/A     RJ-45 at 1.3.4

fiberdriver#
    
```

P1 and P4 are copper RJ-45 Ethernet ports. P2 and P3 are SFP sockets, so the port specifics depend upon the SFP transceivers installed. This example shows P1 configured at 10 Mbps and P4 at 100 Mbps. Only optical SFP port P2 is illustrated because the same variety of SFP is installed in P2 and P3.

Port P1 (Copper)

```

fiberdriver# show 1.3.1
      Port: 1.3.1
      Name: RJ-45 at 1.3.1
Protocol: Ethernet
      Rate: 10Base-T 10 Mbps

Enable: enable
      Link: no Signal           Speed: 10 Mbps
                                Duplex: half
                                Auto Neg: on
                                Adv 10Base-T: on
                                Adv 100Base-Tx: on
                                MDI Pinout: mdix
                                MDI Pinout desired: auto Sense

Connector: RJ45  Medium: twisted Pair
Rx Activity: off  Tx Activity: off

fiberdriver#
    
```

Ports P2 & P3 (SFP)

```
fiberdriver# show 1.3.2
  Port: 1.3.2
  Name: SFP at 1.3.2
Part #/Rev: SFP1250ZXCWDM/1.1
  Protocol: Ethernet
    Rate: 100Base-Tx 100 Mbps

  Enable: enable
    Link: no Signal      Speed: 100 Mbps
                          Nom. BR: 1300
                          Duplex: full

Revertive: no

  Loopback: off
Serial Number: 33BE125099
  Vendor Info: LUMINENT

Connector: fo LC  Medium: single Mode
Wavelength(nm): 1590
  TxPower(dBm): 3.173  RxPower(dBm): -48.587  Bias(mA): 33.239
    DDiags: Ok          Temp(C): 43          Supply(V): 3.266

Rx Activity: off  Tx Activity: off

fiberdriver#
```

Port P4 (Copper)

```
fiberdriver# show 1.3.4
  Port: 1.3.4
  Name: RJ-45 at 1.3.4
  Protocol: Ethernet
    Rate: 10Base-T 10 Mbps

  Enable: enable
    Link: no Signal      Speed: 10 Mbps
                          Duplex: half
                          Auto Neg: on
                          Adv 10Base-T: on
                          Adv 100Base-Tx: on
                          MDI Pinout: mdi
                          MDI Pinout desired: auto Sense

Connector: RJ45  Medium: twisted Pair
Rx Activity: off  Tx Activity: off

fiberdriver#
```

5 Appendix

5.1 Technical Specifications

Operating Temperature Range:

EM316SW-XY → 0° C to 50° C (32° F to 122° F)

EM316SW-XYTH → -35° C to 70° C (-31° F to 158° F)

Storage Temperature: -40° C to 95° C (-40° F to 203° F)

Physical Dimensions: 25 mm x 75 mm x 175 mm deep (1" x 3" x 7" deep)

Weight: 120 - 240 g (4.2 oz to 8.5 oz) depending on configuration

Power: Maximum 10W, dependent on SFP modules installed

5.2 Operating Environment

Temperature: 0 to 45 °C (32 to 113 °F)

Humidity: Non-condensing, less than 85%

Ventilation: 25 mm (1 inch) minimum clearance around external air vents

5.3 Troubleshooting

This section provides basic troubleshooting to rectify the most common issues with the EM316SW-XY. If the information provided in this section and in this manual do not resolve the issue, please do not hesitate to contact MRV Communications Customer Support or your local MRV sales representative.

Basic Troubleshooting Checklist

- Ensure all chassis are powered and operating properly.
- Ensure all modules are inserted correctly and receiving power.
- Ensure SFPs are inserted properly and functioning correctly.
- Ensure User Links are functioning properly and sending the desired signal.
- Ensure Fiber Optic connections are correct (Rx to Tx).
- Ensure Dipswitches are set to the proper settings for your application.
- Ensure the speed, duplex, MDIX (or Auto-Negotiation) is set properly for all RJ-45 User Ports.



**20415 Nordhoff Street
Chatsworth, CA 91311**

**Tel: 818-773-0900
Fax: 818-773-0906
<http://www.mrv.com>**