

***SNAPPER* PRO**™

Parts Manual Fast-Vac

Grass Collection Systems



Models:

5100857
5600002
5600003
5600004
5600057
5600148

Description:

3-Bag Dump From Seat
2-Bag Collection System (S150X - 48" Mower Deck)
3-Bag Collection System (S150X - 48" Mower Deck)
3-Bag Collection System (S150X S/N: 2012628762 & Below - 52" Mower Deck)
3-Bag Collection System (S200X - 61" Mower Deck)
3-Bag Collection System (S150X S/N: 2012628763 & Above - 52" Mower Deck)

Briggs and Stratton Yard Power Products Group

5375 North Main Street
Munnsville, NY 13409 USA
800-933-6175

5101356
Revision 00
Rev. Date: 10/2007
TP 400-7356-00-AT-SP

MODEL COMPONENTS	PAGE
Blower Group	4
Blower Mount & Drive Group	6
2-Bag Catcher & Cover Group	8
3-Bag Catcher & Cover Group	10
3-Bag Dump From Seat	12
Weight Mount Group	14
Decals - Brand, Safety & Information	16
Bagger Mount Group	18
Model Reference Sheet 1 - Models w/Rubber Discharge chute	20
Model Reference Sheet 2 - Models w/Rubber Discharge chute	21
Torque Specification Chart	Inside Back Cover

Blower Group

NOTE: Unless noted otherwise,
use the standard hardware torque
specification chart.

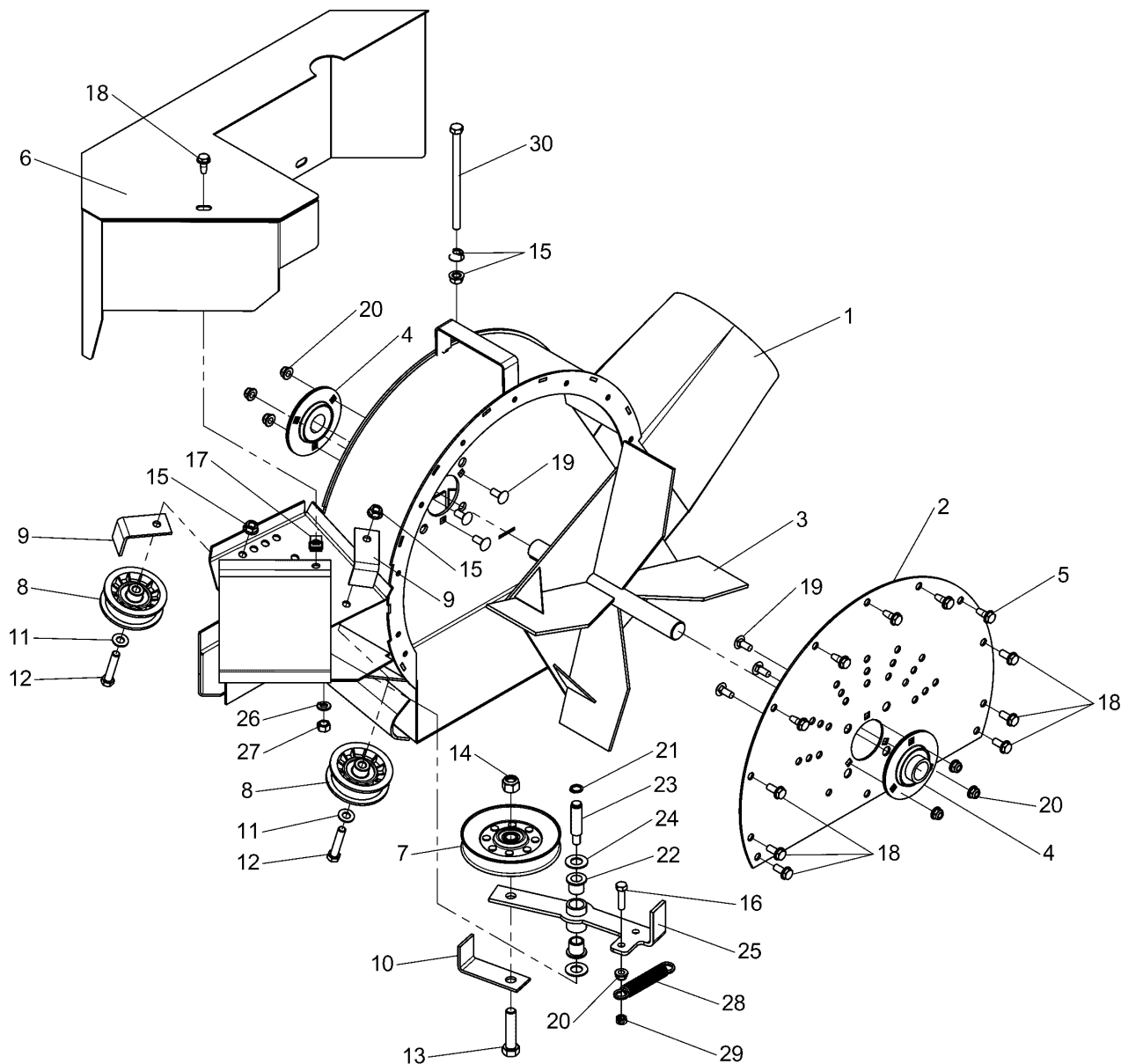

The above parts group applies to the following Mfg. Nos.:

- 5600148 (S150X S/N: 2012628763 & Above - 52" Mower Deck)
- 5600057 (S200X - 61" Mower Deck)
- 5600004 (S150X S/N: 2012628762 & Below - 52" Mower Deck)
- 5600003 (S150X - 48" Mower Deck)
- 5600002 (S150X - 48" Mower Deck)

Blower Group

REF NO	PART NO.	QTY.	DESCRIPTION
1	5403723A	1	BLOWER HOUSING
2	5403750A	1	BACK PLATE
3	5403754A	1	BLOWER IMPELLER
4	7100021	2	BEARING, FLANGE, 1" Bore
5	7091541	5	BOLT, 5/16-18 X 3/4" Self Tap
6	5403736A	1	BELT GUARD
7	5021097	1	PULLEY, IDLER V-NOTCH, 5"
8	3043613	2	IDLER PULLEY ASSEMBLY
9	5403749A	2	BELT KEEPER
10	5403740A	1	KEEPER, BELT TENSIONER
11	5025156	2	WASHER 3/8" SAE
12	5025013X16	2	BOLT, 3/8-16 X 2
13	5025017X18	1	BOLT, 1/2-13 X 2-1/4
14	5025056	1	NUT, 1/2-13 Hex Nylon Lock
15	5025394	4	NUT, 3/8-16 Hex Large Serrated Flange
16	5025011X10	1	BOLT, 5/16-18 X 1-1/4
17	5022308	3	U-CLIP, 5/16-18
18	7091811	6	BOLT, 5/16-18 X 5/8" Self Lock
19	5025145X6	6	CARRIAGE BOLT, 5/16-18 X 3/4
20	5025392	6	NUT, 5/16-18 Hex Nylock Flange
21	7010776	1	RETAINING RING, 1/2"
22	7014409	2	FLANGE BEARING, 9/16"
23	7044995	1	IDLER STUD
24	7091804	2	FLAT WASHER, 9/16" Narrow
25	5403746	1	IDLER ARM
26	5025171	1	WASHER, 3/8 Lock
27	5025035	1	NUT, 3/8-24 Hex
28	5020807	1	SPRING, Extension
29	7091575	1	NUT, 5/16-18 Hex Center Lock
30	5025013X48	1	BOLT, 3/8-16 X 6" GD5

Footnotes

The above parts group applies to the following Mfg. Nos.:

5600148 (S150X S/N: 2012628763 & Above - 52" Mower Deck)

5600057 (S200X - 61" Mower Deck)

5600004 (S150X S/N: 2012628762 & Below - 52" Mower Deck)

5600003 (S150X - 48" Mower Deck)

5600002 (S150X - 48" Mower Deck)

Blower Mount & Drive Group

NOTE: Unless noted otherwise,
use the standard hardware torque
specification chart.

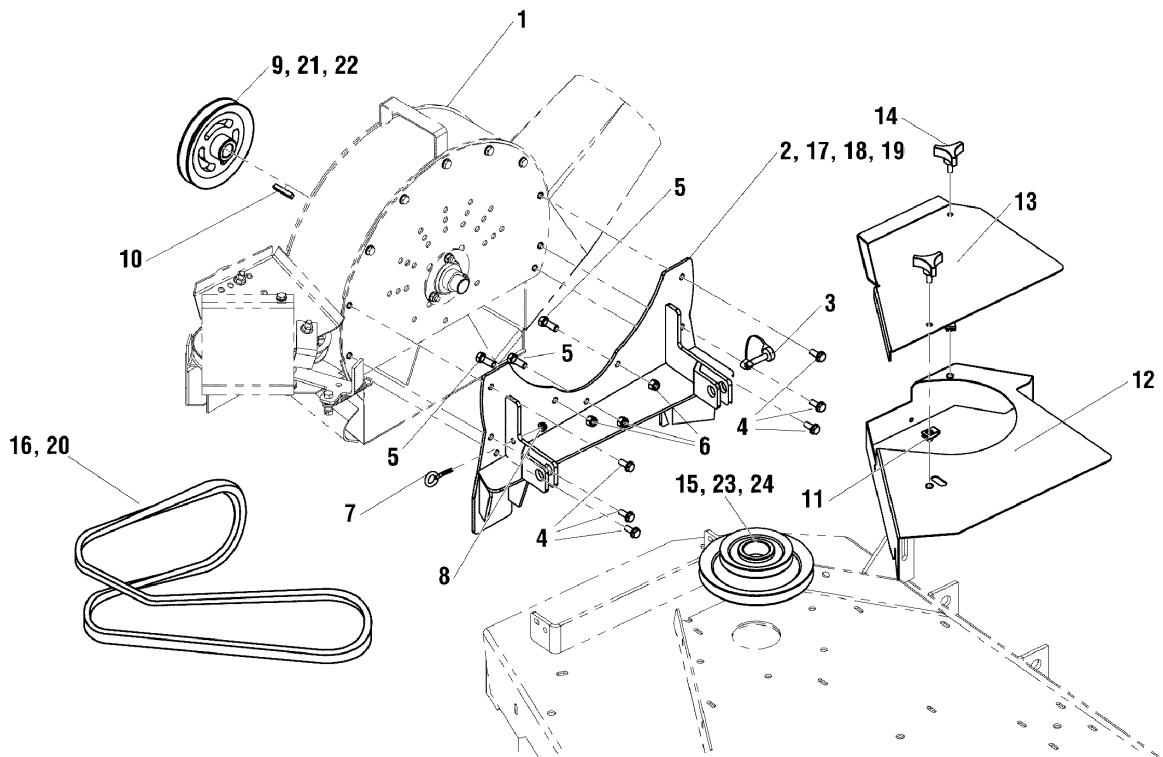

The above parts group applies to the following Mfg. Nos.:

- 5600003 (S150X - 48" Mower Deck)
- 5600004 (S150X S/N: 2012628762 & Below - 52" Mower Deck)
- 5600002 (S150X - 48" Mower Deck)
- 5600057 (S200X - 61" Mower Deck)
- 5600148 (S150X S/N: 2012628763 & Above - 52" Mower Deck)

Blower Mount & Drive Group

REF NO	PART NO.	QTY.	DESCRIPTION
1	-	-	BLOWER ASSEMBLY
2	5402380A	1	WELD, BLOWER MOUNT 61 BLACK (All Models - 61" Mower Deck)
3	5100847	2	SNAPPERPIN, 5/16 X 2
4	7091811	6	BOLT, 5/16-18 X 3/4" SELF LOCK
5	5025013X8	3	BOLT, 3/8-16 X 1" GD5 YZ
6	5025096	3	NUT, 3/8-16 HEX NYLON LOCK
7	5022205	1	EYEBOLT, 1/4-20 X 2
8	5025391	1	NUT, 1/4-20 HEX NYLOCK FLANGE
9	5046807	1	PULLEY, BLOWER AXLE, 52 (All Models - 52" Mower Deck)
10	5022726	1	KEY 1/4 SQ X 1 1/2 LONG
11	5022308	2	BODY CLIP, 5/16-18 X 1/2" DEEP
12	5061858A	1	GUARD, DECK - BLACK (All Models - 48" & 52" Mower Decks)
13	5400007A	1	SHIELD, BELT (All Models - 48" & 52" Mower Decks)
14	5022319	2	KNOB, PLASTIC, 5/16-18 X 3/4"
15	5023177	1	PULLEY, BLOWER 52" DECK (All Models - 52" Mower Deck)
16	5021006	1	BELT, #7-6717, 88.8" E.L. (All Models - 52" Mower Deck)
17	5403650A	1	WELD, BLOWER MOUNT 52 BLACK (S/N: 2012628763 & Above Models - 52" Mower Deck)
18	5402633A	1	WELD, BLOWER MOUNT 48 BLACK (All Models - 48" Mower Deck)
19	5402354A	1	WELD, BLOWER MOUNT 52 BLACK (S/N: 2012628762 & Below Models - 52" Mower Deck)
20	5022844	1	BELT, #7-6718, 92.0" E.L. (All Models - 48" & 61" Mower Decks)
21	5046806	1	PULLEY, BLOWER AXLE, 48 (All Models - 48" Mower Deck)
22	5046808	1	PULLEY, BLOWER AXLE, 61 (All Models - 61" Mower Deck)
23	5023176	1	PULLEY, BLOWER 48" DECK (All Models - 48" Mower Deck)
24	5046702	1	PULLEY, BLOWER 61" DECK (All Models - 61" Mower Deck)
25	5401436A	1	SHIELD, BELT (All Models - 61" Mower Deck)
26	5061858A	1	GUARD, DECK - BLACK (All Models - 61" Mower Deck)

Footnotes

The above parts group applies to the following Mfg. Nos.:

- 5600003 (S150X - 48" Mower Deck)
- 5600004 (S150X S/N: 2012628762 & Below - 52" Mower Deck)
- 5600002 (S150X - 48" Mower Deck)
- 5600057 (S200X - 61" Mower Deck)
- 5600148 (S150X S/N: 2012628763 & Above - 52" Mower Deck)

2-Bag Catcher & Cover Group

NOTE: Unless noted otherwise,
use the standard hardware torque
specification chart.

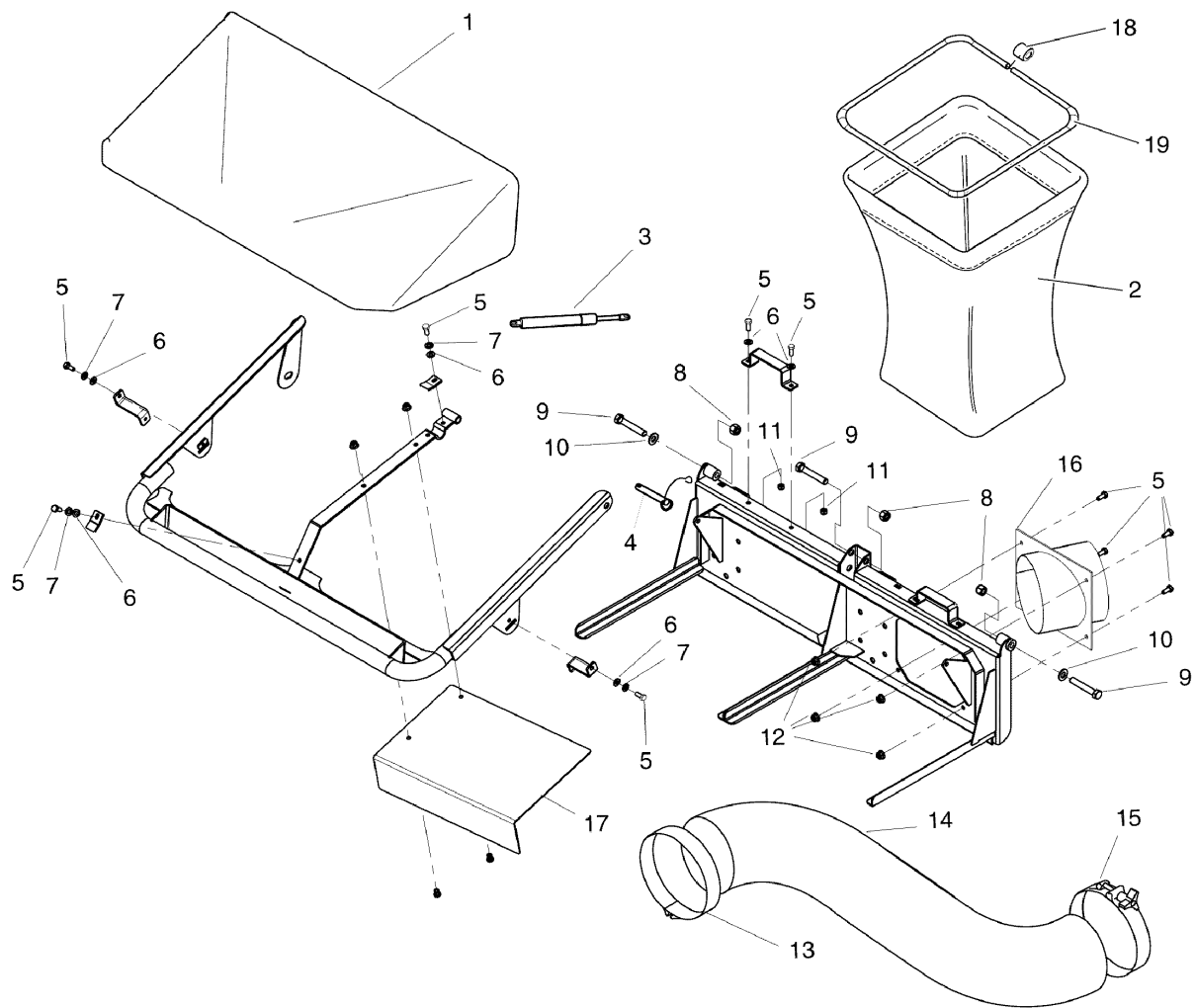

The above parts group applies to the following Mfg. Nos.:
5600002 (S150X - 48" Mower Deck)

2-Bag Catcher & Cover Group

REF NO	PART NO.	QTY.	DESCRIPTION
1	5100153	1	2 BAG AIR DOME
2	5100150	2	CATCHER BAG W/ HANDLE
3	5100152	2	GAS CYLINDER
4	5100151	1	DETENT PIN W/ LANYARD
5	5025011X6	12	BOLT, 5/16-18 X 3/4" GRD5
6	5025155	8	WASHER, 5/16" SAE
7	5025170	4	WASHER, 5/16" LOCK
8	5025056	3	NUT, 1/2-13 HEX NYLON LOCK
9	5025018X24	3	BOLT, 1/2-20 X 3" GD5
10	5025158	2	WASHER, 1/2" SAE
11	5025057	2	NUT 5/16-18 HEX NYLON LOCK
12	5025392	4	NUT 5/16-18 HEX NYLOCK FLANGE
13	5022875	1	HOSE CLAMP
14	5022833	1	HOSE
15	5022876	1	HOSE CLAMP
16	5400147A	1	WELD, INLET BLOWER
17	5100036A	1	BAFFLE
18	5100730	2	BAG FRAME CONNECTOR, PLASTIC
19	5100729	2	BAG FRAME

Footnotes

The above parts group applies to the following Mfg. Nos.:

5600002 (S150X - 48" Mower Deck)

3-Bag Catcher & Cover Group

NOTE: Unless noted otherwise,
use the standard hardware torque
specification chart.

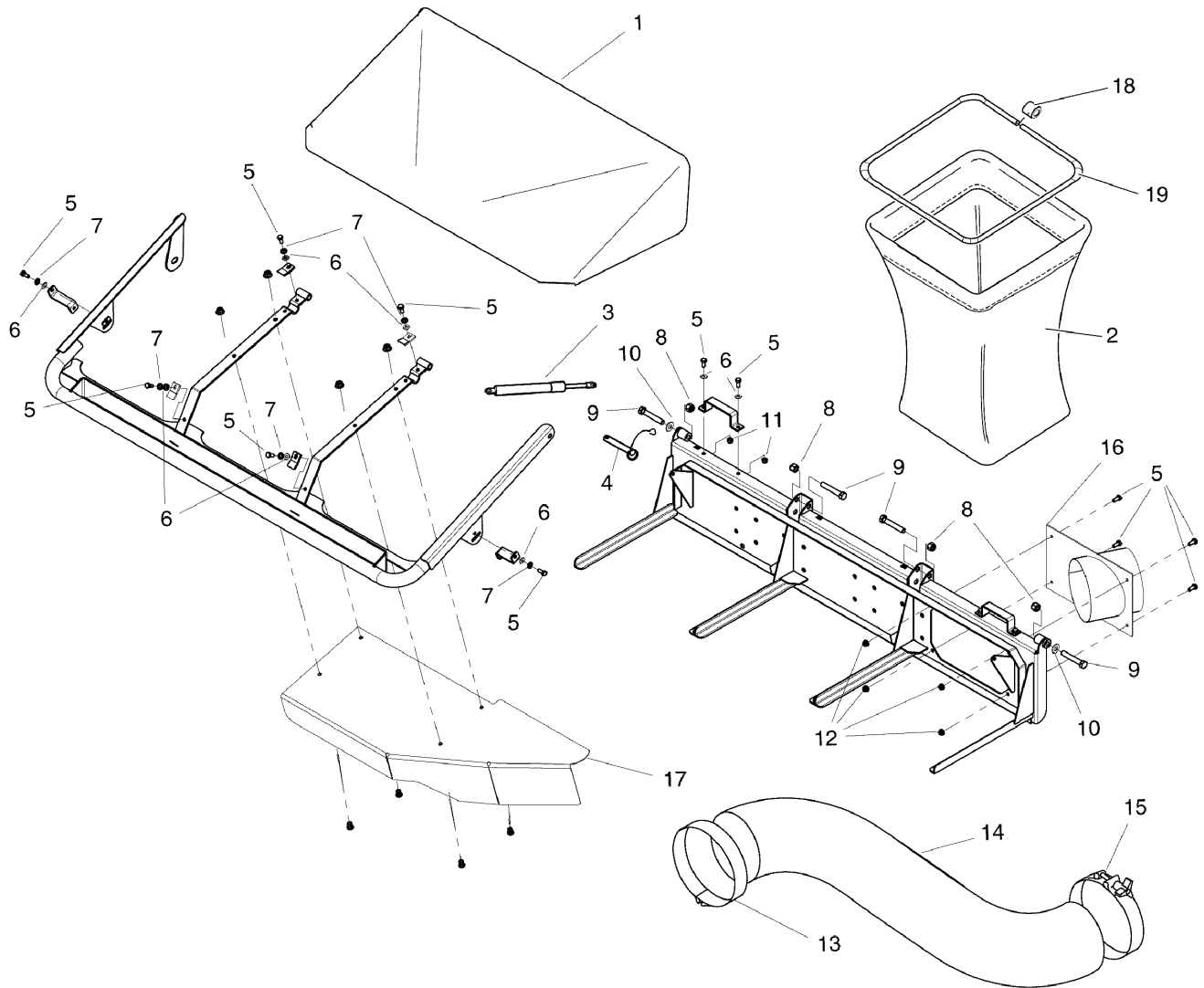

The above parts group applies to the following Mfg. Nos.:

- 5600004 (S150X S/N: 2012628762 & Below - 52" Mower Deck)
- 5600148 (S150X S/N: 2012628763 & Above - 52" Mower Deck)
- 5600003 (S150X - 48" Mower Deck)
- 5600057 (S200X - 61" Mower Deck)

3-Bag Catcher & Cover Group

REF NO	PART NO.	QTY.	DESCRIPTION
1	5100154	1	3 BAG AIR DOME
2	5100150	3	CATCHER BAG W/ HANDLE
3	5100152	2	GAS CYLINDER
4	5100151	1	DETENT PIN W/ LANYARD
5	5025011X6	14	BOLT, 5/16-18 X 3/4" GRD5
6	5025155	10	WASHER, 5/16" SAE
7	5025170	6	WASHER, 5/16" LOCK
8	5025056	4	NUT, 1/2-13 HEX NYLON LOCK
9	5025018X24	4	BOLT, 1/2-20 X 3" GD5
10	5025158	2	WASHER, 1/2" SAE
11	5025057	4	NUT, 5/16-18 HEX NYLON LOCK
12	5025392	4	NUT, 5/16-18 HEX NYLOCK FLANGE
13	5022875	1	CLAMP, HOSE, UPPER
14	5022833	1	HOSE, FLEXIBLE, 7" DIA. X 58
15	5022876	1	CLAMP, HOSE, LOWER
16	5400145A	1	WELD, INLET BLOWER 3-BAG BLACK
17	5400197A	1	BAFFLE
18	5100730	1	BAG FRAME CONNECTOR, PLASTIC
19	5100729	1	BAG FRAME

Footnotes

The above parts group applies to the following Mfg. Nos.:

5600004 (S150X S/N: 2012628762 & Below - 52" Mower Deck)

5600148 (S150X S/N: 2012628763 & Above - 52" Mower Deck)

5600003 (S150X - 48" Mower Deck)

5600057 (S200X - 61" Mower Deck)

3-Bag Dump From Seat

NOTE: Unless noted otherwise,
use the standard hardware torque
specification chart.

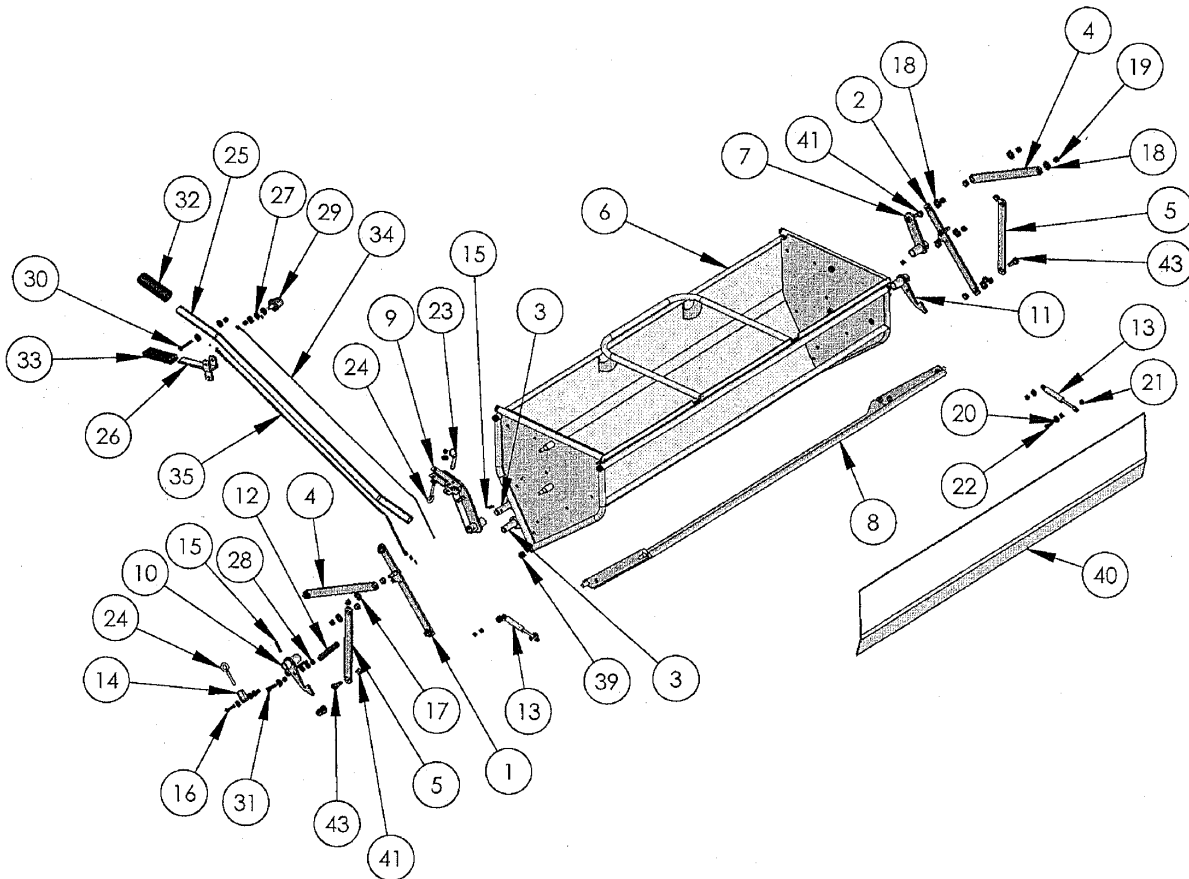

The above parts group applies to the following Mfg. Nos.:

5100857

3-Bag Dump From Seat

REF NO	PART NO.	QTY.	DESCRIPTION
1	5100857X1		MASTER LINK, LH
2	5100857X2		MASTER LINK, RH
4	5100857X4		DRIVE LINK
5	5100857X5		SLAVE LINK
7	5100857X7		TORQUE LINK ASSEMBLY
9	5100857X9		HANDLE PIVOT
10	5100857X10		LATCH ASSEMBLY, LH
11	5100857X11		LATCH ASSEMBLY, RH
12	5100857X12		TENSION SPRING
13	5100857X13		GAS SPRING
14	5100857X14		CABLE ADJUST. BLOCK
26	5100857X26		DFS WELD LEVER
29	5100857X29		RUBBER STOPPER
32	5100857X32		RUBBER GRIP
33	5100857X33		RUBBER GRIP
34	5100857X34		1/16 CABLE
37	5100857X37		1/16 CABLE TIE
41	5100857X41		FLANGE BUSHING
43	5100857X43		SHOULDER BOLT

Footnotes

The above parts group applies to the following Mfg. Nos.:

5100857

Weight Mount Group

NOTE: Unless noted otherwise,
use the standard hardware torque
specification chart.

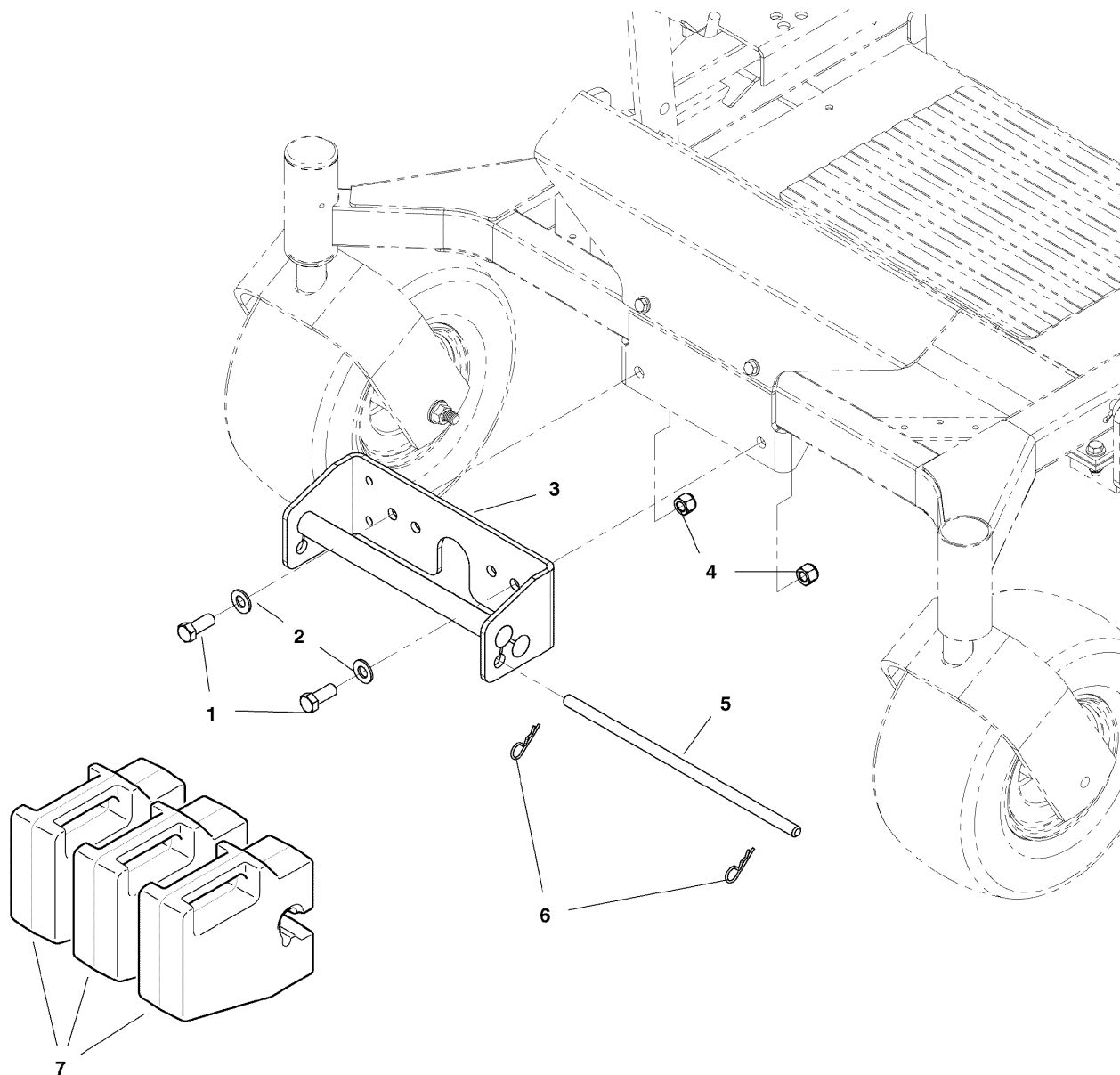

The above parts group applies to the following Mfg. Nos.:

5600148 (S150X S/N: 2012628763 & Above - 52" Mower Deck)

5600057 (S200X - 61" Mower Deck)

5600002 (S150X - 48" Mower Deck)

5600003 (S150X - 48" Mower Deck)

5600004 (S150X S/N: 2012628762 & Below - 52" Mower Deck)

Weight Mount Group

REF NO	PART NO.	QTY.	DESCRIPTION
1	5025018X10	2	BOLT, 1/2-20 X 1-1/4" GD5 YZ
2	5025158	2	WASHER, 1/2 SAE
3	5049082A	1	HOLDER ASMY - WEIGHT
4	5025098	2	NUT, 1/2-20 HEX NYLON LOCK
5	5049143	1	ROD- .500DIA 13.75LG YELLOW
6	5025210	2	PIN, HAIR
7	1717627	3	WEIGHT, 50LBS

Footnotes

The above parts group applies to the following Mfg. Nos.:

5600148 (S150X S/N: 2012628763 & Above - 52" Mower Deck)

5600057 (S200X - 61" Mower Deck)

5600002 (S150X - 48" Mower Deck)

5600003 (S150X - 48" Mower Deck)

5600004 (S150X S/N: 2012628762 & Below - 52" Mower Deck)

Decals - Brand, Safety & Information

NOTE: Unless noted otherwise, use the standard hardware torque specification chart.

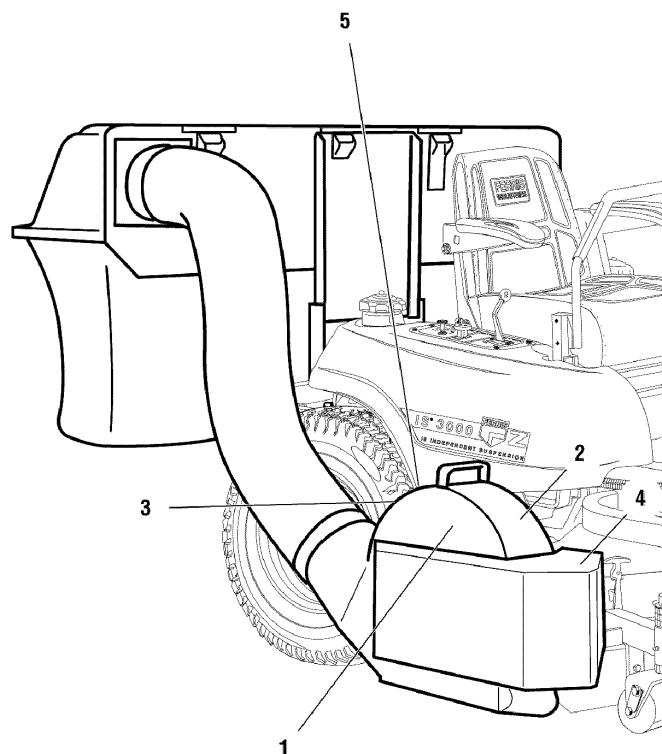

1 — **FAST-Vac**



The above parts group applies to the following Mfg. Nos.:

5600004 (S150X S/N: 2012628762 & Below - 52" Mower Deck)

5600003 (S150X - 48" Mower Deck)

5600148 (S150X S/N: 2012628763 & Above - 52" Mower Deck)

5600002 (S150X - 48" Mower Deck)

5600057 (S200X - 61" Mower Deck)

Decals - Brand, Safety & Information

REF NO	PART NO.	QTY.	DESCRIPTION
1	5046944	1	DECAL, Fast-Vac
2	5046850	1	DECAL, Danger/Warning
3	5046851	1	DECAL, Warning-Blower
4	5046883	1	DECAL, Warning-Shield
5	7027733	1	DECAL, Ear Protection

Footnotes

The above parts group applies to the following Mfg. Nos.:

5600004 (S150X S/N: 2012628762 & Below - 52" Mower Deck)

5600003 (S150X - 48" Mower Deck)

5600148 (S150X S/N: 2012628763 & Above - 52" Mower Deck)

5600002 (S150X - 48" Mower Deck)

5600057 (S200X - 61" Mower Deck)

Bagger Mount Group

NOTE: Unless noted otherwise,
use the standard hardware torque
specification chart.

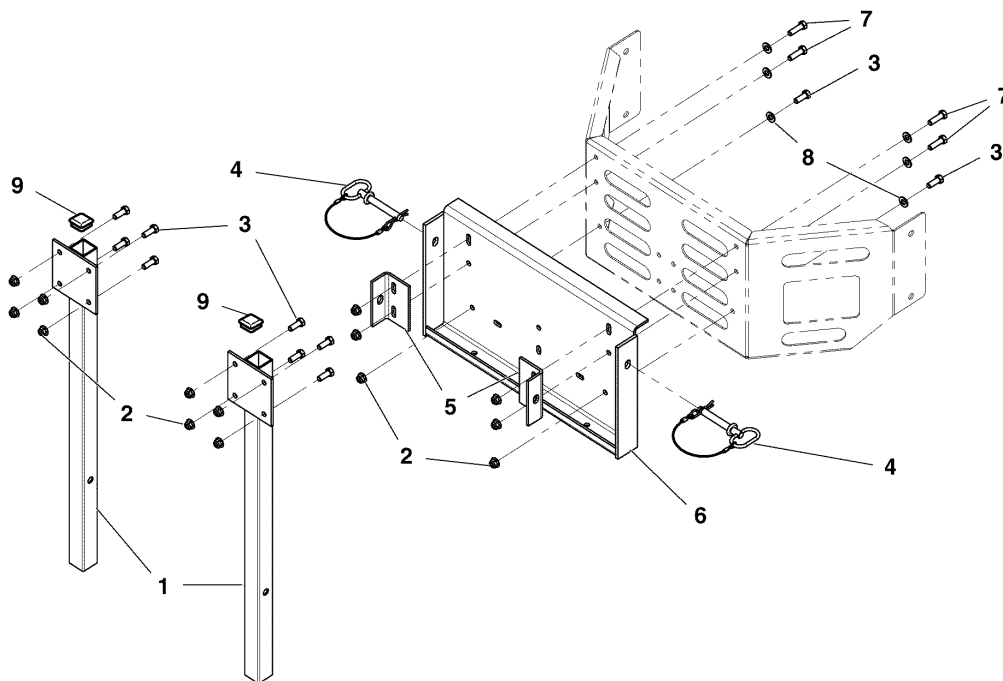

The above parts group applies to the following Mfg. Nos.:

- 5600002 (S150X - 48" Mower Deck)
- 5600057 (S200X - 61" Mower Deck)
- 5600148 (S150X S/N: 2012628763 & Above - 52" Mower Deck)
- 5600003 (S150X - 48" Mower Deck)
- 5600004 (S150X S/N: 2012628762 & Below - 52" Mower Deck)

Bagger Mount Group

REF NO	PART NO.	QTY.	DESCRIPTION
1	5400043A	2	WELD, MOUNT, POST
2	5025394	14	NUT, 3/8-16 HEX NYLOCK FLANGE
3	5025013X8	10	BOLT, 3/8-16 X 1" GD5 YZ
4	5100013	2	PIN, HITCH, .50 X 3.25 W/ LAY
5	5400041A	2	MOUNT, TAB, BLACK
6	5400149A	1	WELD, BAGGER MOUNT
7	5025013X10	4	BOLT, 3/8-16 X 1-1/4" GD5 YZ
8	5025156	6	WASHER 3/8" SAE
9	5022848	2	CAP, PLASTIC, 1-1/2" X 1-1/2"

Footnotes

The above parts group applies to the following Mfg. Nos.:

5600002 (S150X - 48" Mower Deck)

5600057 (S200X - 61" Mower Deck)

5600148 (S150X S/N: 2012628763 & Above - 52" Mower Deck)

5600003 (S150X - 48" Mower Deck)

5600004 (S150X S/N: 2012628762 & Below - 52" Mower Deck)

9/24/2007



FAST-Vac Grass Collection Systems (2005 Model Year & Later)

IMPORTANT NOTE: These kits will only fit models equipped with the rubber discharge chute.

N/A = Not available.

Mower Deck Size	2-Bag System	3-Bag System
44" Ferris IS500Z & IS1500Z Series - Model #: 5900614, 5900605 & 5900640	5600001	N/A
48" Ferris IS1500Z Series - Model #: 5900615 & 5900606 Snapper Pro S150x Series - Model #: 5900686 & 5900696	5600002	5600003
52" Ferris IS1500Z Series - Model #: 5900616 & 5900607 (S/N: 2012628762 & Below) Snapper Pro S150x Series - Model #: 5900665 & 5900697 (S/N: 2012628762 & Below)	N/A	5600004
52" Ferris IS1500Z Series - Model #: 5900616 & 5900607 (S/N: 2012628763 & Above) Snapper Pro S150x Series - Model #: 5900665 & 5900697 (S/N: 2012628763 & Above)	N/A	5600148
52" Ferris IS1000Z Series (S/N: 2531 & Above)	N/A	5600007
52" Ferris IS2000Z Series - Model #: 5900624 & 5900625 (S/N: 2012628762 & Below)	N/A	5600061
52" Ferris IS2000Z Series - Model #: 5900624 & 5900625 (S/N: 2012628763 & Above)	N/A	5600150
61" Ferris 1000Z Series (S/N: 2899 & Above)	N/A	5600008
61" Ferris IS2000Z Series - Model #: 5900619 & 5901170 Snapper Pro S200x Series - Model #: 5900664, 5900692 & 5900695	N/A	5600057
61" Ferris IS3000Z & IS3000ZX Series (S/N: 3631 & Above)	N/A	5600006
61" Ferris IS3000ZL Series - Model #: 5901059	N/A	5600005
61" Ferris IS3100Z Series - Model #: 5900611, 5900612 & 5900613	N/A	5600060
61" Ferris IS4500Z Series - Model #: 5900159, 5900160, 5901180 & 5901179	N/A	5600009

See Reverse for Kit Contents

5600059
Rev. H 9/24/2007

The above parts group applies to the following Mfg. Nos.:

- 5600057 (S200X - 61" Mower Deck)
- 5600148 (S150X S/N: 2012628763 & Above - 52" Mower Deck)
- 5600004 (S150X S/N: 2012628762 & Below - 52" Mower Deck)
- 5600003 (S150X - 48" Mower Deck)
- 5600002 (S150X - 48" Mower Deck)



FAST-Vac Grass Collection Systems (2005 Model Year & Later)

IMPORTANT NOTE: These kits will only fit models equipped with the rubber discharge chute.

Kit Contents:

5600001

- (1) 5900800 - FAST-Vac Blower
- (1) 5100001 - 2-Bag Collector
- (1) 5300012 - 2-Bag Mount
- (1) 5300005 - Blower Mount
- (1) 5300189 - Weight Mount
- (2) 1717627 - Weight, 50lbs.

5600002

- (1) 5900800 - FAST-Vac Blower
- (1) 5100001 - 2-Bag Collector
- (1) 5300012 - 2-Bag Mount
- (1) 5300006 - Blower Mount
- (1) 5300189 - Weight Mount
- (2) 1717627 - Weight, 50lbs.

5600003

- (1) 5900800 - FAST-Vac Blower
- (1) 5100002 - 3-Bag Collector
- (1) 5300019 - 3-Bag Mount
- (1) 5300006 - Blower Mount
- (1) 5300189 - Weight Mount
- (3) 1717627 - Weight, 50lbs.

5600004

- (1) 5900800 - FAST-Vac Blower
- (1) 5100002 - 3-Bag Collector
- (1) 5300019 - 3-Bag Mount
- (1) 5300007 - Blower Mount
- (1) 5300189 - Weight Mount
- (3) 1717627 - Weight, 50lbs.

5600005

- (1) 5900800 - FAST-Vac Blower
- (1) 5100002 - 3-Bag Collector
- (1) 5300014 - 3-Bag Mount
- (1) 5300009 - Blower Mount
- (1) 5046869 - Weight Mount
- (3) 1717627 - Weight, 50lbs.

5600006

- (1) 5900800 - FAST-Vac Blower
- (1) 5100002 - 3-Bag Collector
- (1) 5300014 - 3-Bag Mount
- (1) 5300008 - Blower Mount
- (1) 5046869 - Weight Mount
- (3) 1717627 - Weight, 50lbs.

5600007

- (1) 5900800 - FAST-Vac Blower
- (1) 5100002 - 3-Bag Collector
- (1) 5300022 - 3-Bag Mount
- (1) 5300016 - Blower Mount
- (1) 5047609 - Weight Mount
- (2) 1717627 - Weight, 50lbs.

5600008

- (1) 5900800 - FAST-Vac Blower
- (1) 5100002 - 3-Bag Collector
- (1) 5300022 - 3-Bag Mount
- (1) 5300020 - Blower Mount
- (1) 5061134 - Weight Mount
- (3) 1717627 - Weight, 50lbs.

5600009

- (1) 5900800 - FAST-Vac Blower
- (1) 5100002 - 3-Bag Collector
- (1) 5300019 - 3-Bag Mount
- (1) 5300010 - Blower Mount
- (1) 5300189 - Weight Mount
- (3) 1717627 - Weight, 50lbs.
- (1) 5600019 - Bumper Kit

5600057

- (1) 5900800 - FAST-Vac Blower
- (1) 5100002 - 3-Bag Collector
- (1) 5300019 - 3-Bag Mount
- (1) 5300188 - Blower Mount
- (1) 5300189 - Weight Mount
- (3) 1717627 - Weight, 50lbs.

5600060

- (1) 5900800 - FAST-Vac Blower
- (1) 5100002 - 3-Bag Collector
- (1) 5300117 - 3-Bag Mount
- (1) 5300009 - Blower Mount
- (1) 5046869 - Weight Mount
- (3) 1717627 - Weight, 50lbs.

5600061

- (1) 5900800 - FAST-Vac Blower
- (1) 5100002 - 3-Bag Collector
- (1) 5300019 - 3-Bag Mount
- (1) 5300223 - Blower Mount
- (1) 5300189 - Weight Mount
- (3) 1717627 - Weight, 50lbs.

5600059

Rev. H 9/24/2007

The above parts group applies to the following Mfg. Nos.:

- 5600057 (S200X - 61" Mower Deck)
- 5600148 (S150X S/N: 2012628763 & Above - 52" Mower Deck)
- 5600004 (S150X S/N: 2012628762 & Below - 52" Mower Deck)
- 5600003 (S150X - 48" Mower Deck)
- 5600002 (S150X - 48" Mower Deck)

Hardware Identification & Torque Specifications

Common Hardware Types

Hex Head Capscrew

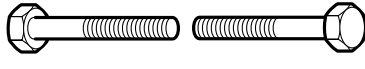

Washer



Carriage Bolt



Lockwasher



Hex Nut



Standard Hardware Sizing

When a washer or nut is identified as $1/2''$, this is the *Nominal size*, meaning the *inside diameter* is $1/2$ inch; if a second number is present it represents the *threads per inch*

When bolt or capscrew is identified as $1/2 - 16 \times 2''$, this means the *Nominal size*, or *body diameter* is $1/2$ inch; the second number represents the *threads per inch* (16 in this example, and the final number is the *body length* of the bolt or screw (in this example 2 inches long).

The guides and ruler furnished below are designed to help you select the appropriate hardware and tools.

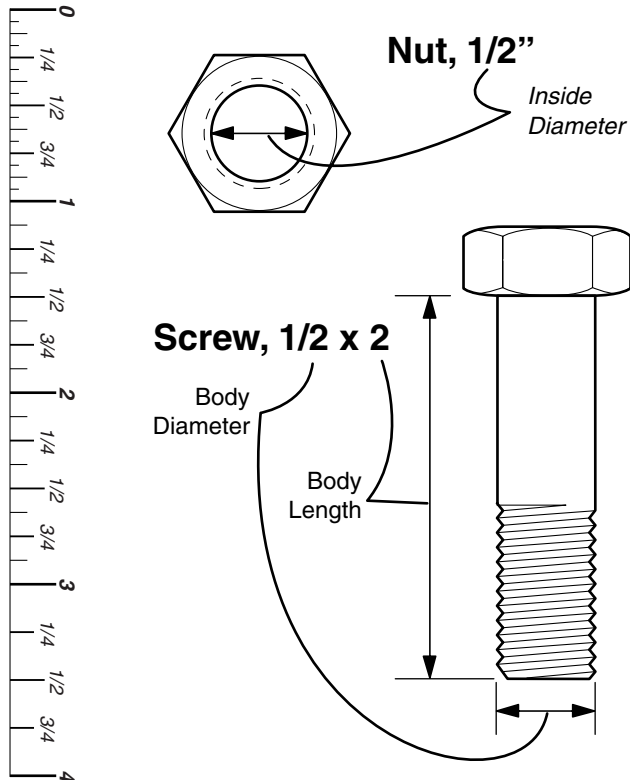

Torque Specification Chart

FOR STANDARD MACHINE HARDWARE (Tolerance $\pm 20\%$)

Hardware Grade	No Marks SAE Grade 2		SAE Grade 5		SAE Grade 8	
	in/lbs ft/lbs	Nm.	in/lbs ft/lbs	Nm.	in/lbs ft/lbs	Nm.
8-32	19	2.1	30	3.4	41	4.6
8-36	20	2.3	31	3.5	43	4.9
10-24	27	3.1	43	4.9	60	6.8
10-32	31	3.5	49	5.5	68	7.7
1/4-20	66	7.6	8	10.9	12	16.3
1/4-28	76	8.6	10	13.6	14	19.0
5/16-18	11	15.0	17	23.1	25	34.0
5/16-24	12	16.3	19	25.8	27	34.0
3/8-16	20	27.2	30	40.8	45	61.2
3/8-24	23	31.3	35	47.6	50	68.0
7/16-14	30	40.8	50	68.0	70	95.2
7/16-20	35	47.6	55	74.8	80	108.8
1/2-13	50	68.0	75	102.0	110	149.6
1/2-20	55	74.8	90	122.4	120	163.2
9/16-12	65	88.4	110	149.6	150	204.0
9/16-18	75	102.0	120	163.2	170	231.2
5/8-11	90	122.4	150	204.0	220	299.2
5/8-18	100	136	180	244.8	240	326.4
3/4-10	160	217.6	260	353.6	386	525.0
3/4-16	180	244.8	300	408.0	420	571.2
7/8-9	140	190.4	400	544.0	600	816.0
7/8-14	155	210.8	440	598.4	660	897.6
1-8	220	299.2	580	788.8	900	1,244.0
1-12	240	326.4	640	870.4	1,000	1,360.0

NOTES

- These torque values are to be used for all hardware excluding: locknuts, self-tapping screws, thread forming screws, sheet metal screws and socket head setscrews.
- Recommended seating torque values for locknuts:
 - for prevailing torque locknuts - use 65% of grade 5 torques.
 - for flange whizlock nuts and screws - use 135% of grade 5 torques.
- Unless otherwise noted on assembly drawings, all torque values must meet this specification.

Wrench & Fastener Size Guide



$1/4''$ Bolt or Nut
Wrench— $7/16''$

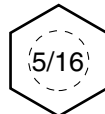

$5/16''$ Bolt or Nut
Wrench— $1/2''$

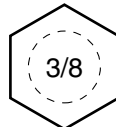

$3/8''$ Bolt or Nut
Wrench— $9/16''$

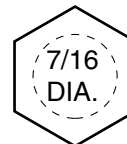

$7/16''$ Bolt or Nut
Wrench (Bolt)— $5/8''$
Wrench (Nut)— $11/16''$

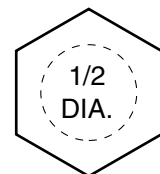

$1/2''$ Bolt or Nut
Wrench— $3/4''$

Parts Manual Fast-Vac

Grass Collection Systems

IT IS THE POLICY OF FERRIS INDUSTRIES TO IMPROVE ITS PRODUCTS WHENEVER IT IS POSSIBLE AND PRACTICAL TO DO SO. WE RESERVE THE RIGHT TO MAKE CHANGES OR ADD IMPROVEMENTS AT ANY TIME WITHOUT INCURRING ANY OBLIGATION TO MAKE SUCH CHANGES ON PRODUCTS MANUFACTURED

Briggs and Stratton Yard Power Products Group

5375 North Main Street
Munnsville, NY 13409 USA
800-933-6175

www.ferrisindustries.com

© Copyright 2007 Briggs and Stratton Corporation
All Rights Reserved. Printed In USA.