

Earthquake®

Vertical / Horizontal **LOG SPLITTER**

Assembly & Operating Instructions

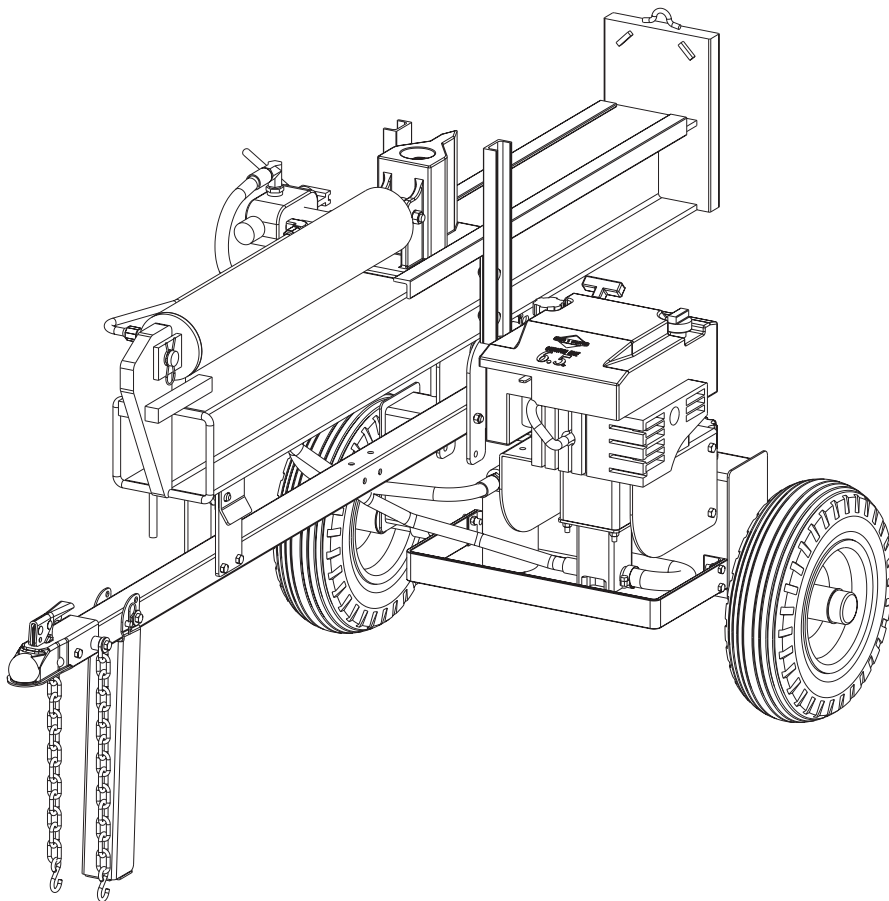

**Includes Models
W2265 & W2808**

OM-WS2265-04 Rev-030904
© Copyright 2004 Ardisam, Inc.
All Rights Reserved. Printed in USA.

THANK YOU . . .

for purchasing an Earthquake® Log Splitter from Ardisam, Inc. We guarantee that this log splitter conforms to applicable North American safety standards, and have worked to ensure that it meets high standards for usability and durability. With proper care, it will provide you with many years of service. Please take the time to read this booklet carefully to learn how to correctly assemble and operate your log splitter. Congratulations on your investment in quality.

MODEL IDENTIFICATION

Record your model number, manufacturer number and serial number in the space provided for easy reference. The model and manufacturer numbers can be found on the inside leg of the engine mount plate. Refer to the Engine Owner's Manual for location of engine serial number.

LOG SPLITTER REFERENCE DATA	
Model Description/Number	
M/N (Manufacturer's Number)	S/N (Serial Number)
Dealer Name	Date Purchased
Engine Make/Model	Engine ID/Serial Number

One Year Limited Warranty

The Ardisam, Inc., Manufacturing Company warrants this Earthquake® Log Splitter to be free from defects in material or workmanship for the normal service life of the product not to exceed 12 consecutive months from the date of purchase. The cylinder, valve, pump and other hydraulic components are guaranteed for two (2) years from the date of purchase. The engine is covered under a separate warranty provided by the manufacturer and is enclosed with the owner/operator's manual. Conditions of this warranty include:

What is covered under warranty:

Ardisam, Inc. will repair or replace any part that in our judgement is found to be defective in material or workmanship during the warranty period stated above after delivery of the log splitter to the original purchaser.

What is not covered under warranty:

This warranty applies only to products which **have not** been subjected to negligent use, misuse, alteration, accident or if repairs have been made by anyone outside our factory. This warranty applies only to the original purchaser, and is not transferrable.

How to obtain service:

Return the product to us at the address below with transportation charges prepaid.

This warranty supersedes all other warranties either expressed or implied and all other obligations or liabilities on our part. Ardisam, Inc., does not assume, and does not authorize any other person to assume for us, any liability in connection with the sale of our products. This guarantee is void unless warranty card is properly filled out and returned to Ardisam, Inc., Cumberland, Wisconsin, at time of purchase.



Ardisam, Inc.
1690 Elm Street, Cumberland, WI 54829
Phone (715) 822-2415 Fax (715) 822-4180
Email info@ardisam.com
www.ardisam.com

SAFETY INSTRUCTIONS

- **Before operating this log splitter, carefully read this manual and follow all instructions.**
- **Do not** allow anyone to operate your log splitter who has not read this manual.
- **Never** operate your log splitter for any other purpose than splitting wood.
- **Do not** operate the log splitter under the influence of alcohol, drugs or medication.
- **Never** allow children to operate the log splitter. Keep small children away from the work area. If a second person is assisting in loading logs, **never** activate the log splitter until the helper is clear of the work area.

PREPARATION

- Dress appropriately when operating the log splitter. **Always** wear safety footwear. **Never** wear sandals, sneakers, or open shoes, and **never** operate the log splitter with bare feet. **Do not** wear loose clothing or jewelry that might get caught in moving parts.
- **Always** wear safety glasses while operating your log splitter. Wear proper head gear to keep hair away from moving parts.
- **Always** wear a protective hearing device.
- If you wear gloves, **be sure** they are tight fitting without loose cuffs or draw strings.
- Both ends of each log should be cut as square as possible to help prevent the log from sliding out of the splitter during operation.
- **Handle** fuel with care; it is highly flammable.
 - a. **Use** an approved fuel container.
 - b. **Never** add fuel to a running engine or hot engine.
 - c. **Fill** fuel tank outdoors with extreme care. **Never** fill fuel tank indoors.
 - d. **Replace** gasoline cap securely and clean up spilled fuel before restarting.
- **Never** attempt to make any adjustments to the log splitter while the engine is running.

OPERATING PROCEDURE

- **Never** operate the log splitter without guards in place.
- **Only** operate the log splitter from the operator zone.
- Know how to stop the unit and disengage the controls.
- **Never** place hands and/or feet between log and splitting wedge or between log and ram during forward or reverse stroke.
- **Do not** step over or straddle the log splitter when the engine is running. **Never** reach or bend over the log splitter to pick up a log.
- **Never** try to split two logs on top of each other at the same time.
- **Never** allow one person to operate the valve while another is positioning the log.
- **Never** attempt to load your log splitter when the ram is in motion.
- **Only** use your hand to operate the control lever. **Never** use your foot or a rope or any other extension device.
- **Always** keep fingers away from any cracks that open in the log during splitting operation.
- **Never** move the log splitter while the engine is running.
- **Never** leave your log splitter unattended with the engine running. Shut off the engine if you are leaving your splitter--even for a short period of time.
- **Do not** run the engine in an enclosed area. Exhaust gases contain carbon monoxide. This odorless gas can be deadly when inhaled.
- **Do not** operate your log splitter on slippery, wet, muddy, or icy surfaces.
- **Only** operate your log splitter on level ground and not on a hillside.
- **Never** attempt to move the log splitter over hilly or uneven terrain without a tow vehicle or adequate help.
- **Always** block wheels to prevent movement of log splitter while in operation.
- **Keep** work area clean. Immediately remove split wood around your log splitter so that you don't stumble over it.
- **Always** use your log splitter in daylight.

REPAIR AND MAINTENANCE SAFETY

- **Do not** operate your log splitter in poor mechanical condition or when in need of repair.
- Periodically check that all nuts, bolts, and screws are tightened.
- **Always** perform recommended maintenance procedures before using your log splitter.
- **Do not** alter your log splitter in any manner such as attaching a rope or extension to the control lever or adding to the width or height of the wedge.
- **Replace** all damaged or worn parts immediately.
- **Never** tamper with the engine to have it run at excessive speeds. The maximum engine speed is preset by the manufacturer.
- **Do not** service or repair your log splitter without removing the spark plug wire.
- All replacement parts must meet manufacturer's specifications.

TOWING SAFETY

- **Obey** all state and local regulations when towing on public roads and highways.
- Before towing, be certain that the log splitter is correctly and securely attached to the towing vehicle and that a safety chain is in place.
- **Never** carry any cargo or wood on your log splitter. Do not allow anyone to sit or ride on your log splitter.
- Before using your log splitter, disconnect it from the towing vehicle.
- **Allow** for added length of your log splitter when turning, parking, crossing an intersection, and in all driving situations.
- Be careful when backing up.
- **Adjust** towing speed for terrain and conditions. Do not exceed 45 mph. Be extra cautious and reduce speed when towing over bumpy or rough terrain including railroad crossing.

FIRE PREVENTION

- **Never** operate your log splitter near a flame or spark. Hydraulic oil and gasoline are flammable and can explode.
- **Do not** fill the gas tank while the engine is hot or running. Allow the engine to cool before refueling.
- **Never** smoke while operating or refueling your log splitter. Gas fumes can easily explode.
- Only refuel your log splitter outdoors in a clear area. **Always** use an approved fuel container. **Always** replace the gas cap securely.
- If gas is spilled, move machine away from the area of the spill and avoid creating any source of ignition until the spilled gas has evaporated or been cleaned up.
- Take a Class B fire extinguisher with you when operating your log splitter in dry areas as a precautionary measure against possible flying sparks.
- Completely drain the fuel tank prior to storage.
- **Always** store gasoline in an approved, tightly sealed container. Store the container in a cool, dry place. **Do not** store in the houses or near a heating appliance.

HYDRAULIC SAFETY

- The hydraulic system of your log splitter requires careful inspection along with the mechanical parts. **Be sure** to replace any damaged hydraulic component.
- Fluid escaping from a very small hole can almost be invisible. **Do not** check for leaks with your hand. Escaping fluid under pressure can have sufficient force to penetrate skin, causing serious personal injury or even death. Leaks can be located by passing a piece of cardboard or wood over the suspected leak. Look for discoloration.
- If injured by escaping fluid, see a doctor at once. Serious infection or reaction can develop if proper medical treatment is not administered immediately.
- Should it become necessary to loosen or remove any hydraulic fitting or line, be sure to relieve all pressure by shutting off the engine and moving the control handle back and forth several times.
- The pressure relief valve on your log splitter is preset at the factory. **Do not** adjust the valve. Only a qualified service technician should perform this adjustment.

⚠ WARNING

- READ AND UNDERSTAND OPERATOR'S MANUAL THOROUGHLY BEFORE OPERATION. FAILURE TO DO SO MAY RESULT IN SERIOUS INJURY.
- KEEP ALL SHIELDS IN PLACE.
- KEEP HANDS, FEET AND CLOTHING AWAY FROM POWER-DRIVEN PARTS.
- ALWAYS WEAR SAFETY GLASSES AND SAFETY SHOES DURING OPERATION.
- ALWAYS OPERATE OUT-OF-DOORS WITH GOOD VENTILATION.
- ALWAYS STOP ENGINE AND REMOVE SPARK PLUG WIRE BEFORE PERFORMING MAINTENANCE OPERATIONS.
- ALWAYS SHUT OFF ENGINE WHEN LEAVING LOG SPLITTER UNATTENDED, EVEN FOR A SHORT PERIOD OF TIME.
- ONLY ONE PERSON SHOULD LOAD AND OPERATE THE LOG SPLITTER. KEEP ALL OTHERS CLEAR DURING OPERATION. NEVER ALLOW ONE PERSON TO OPERATE VALVE WHILE ANOTHER IS POSITIONING THE LOG.
- ALWAYS POSITION LOG WITH HANDS ON THE SIDES OF LOG. KEEP HANDS CLEAR OF ENDS.
- KEEP ALL CHILDREN AWAY FROM THE LOG SPLITTER.
- DO NOT STEP OVER THE LOG SPLITTER.
- ONLY USE HANDS TO OPERATE THE CONTROL VALVE.
- DO NOT OPERATE THE LOG SPLITTER WHILE UNDER THE INFLUENCE OF ALCOHOL, DRUGS OR MEDICATION.
- ALWAYS OPERATE THE LOG SPLITTER ON LEVEL, DRY, NON-SLIPPERY SURFACES. KEEP OFF SLOPES.
- KEEP WORK AREA CLEAR OF SPLIT WOOD, DEBRIS OR OTHER OBSTACLES.
- ALWAYS STAY IN THE OPERATOR ZONE WHEN USING THE LOG SPLITTER.
- ALWAYS SPLIT WOOD IN THE DIRECTION OF THE GRAIN ONLY.
- DO NOT ADD GASOLINE WHILE THE ENGINE IS HOT OR RUNNING. ALLOW ALL SPILLED GAS TO EVAPORATE BEFORE USING LOG SPLITTER.

LBL4178

Part Number: LBL4178
 Description: All General Warnings Decal
 Location: Back of Hydraulic Reservoir

⚠ WARNING

- FAILURE TO FOLLOW THESE RULES CAN CAUSE TRAILER TO DETACH WHILE TOWING AND MAY RESULT IN SERIOUS INJURY OR DEATH.
- DO NOT EXCEED WEIGHT CAPACITY OF BALL OR LOAD LIMITS STAMPED ON COUPLER.
- ALWAYS USE SAFETY CHAINS WHEN TOWING.
- ALWAYS CHECK THAT THE COUPLER HANDLE IS LOCKED BEFORE TOWING.
- ALWAYS USE THE CORRECT BALL SIZE THAT IS STAMPED ON COUPLER.
- ALWAYS ADJUST COUPLER LOCKING PRESSURE ON BALL BEFORE USE.
- CHECK COUPLER TIGHTNESS BEFORE TOWING AND AFTER TOWING 50 MILES.
- ALWAYS CHECK COUPLER AND BALL FOR DAMAGE BEFORE TOWING. REPLACE IF DAMAGED.
- AVOID SHARP TURNS AND STEEP VERTICAL ANGLES WHEN TOWING TO PREVENT DAMAGE TO COUPLER OR ITS COMPONENTS.

LBL4179

Part Number: LBL4179
 Description: Towing Warning Decal
 Location: Tongue Near Trailer Hitch Coupler

OPERATING INSTRUCTIONS

- 1) Before using, adjust coupler locking pressure on ball. Put handle in locked position with ball in coupler. Tighten locknut against tension spring so that coupler is firmly on ball. The proper adjustment allows handle to be released with moderate pressure.
- 2) Pull up on coupler handle to open and place coupler over ball. When ball is seated in ball socket pull back on handle to locked position.
- 3) Check to make sure the coupler is tight on the ball after towing for 50 miles. Always check for tightness before towing and make sure handle is in locked position.

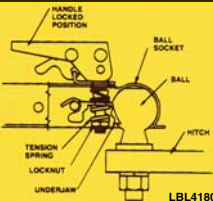

LBL4180

Part Number: LBL4180
 Description: Coupler Operating Instructions Decal
 Location: Tongue Near Trailer Hitch Coupler

⚠ WARNING

DO NOT TOUCH LEAKS

- High Pressure fluid easily penetrates skin and infects blood - causing injury, gangrene or death.
- Seek emergency medical help at once if injured, liquid needs to be removed from tissue.
- Do not reach for or use any skin to check for leaks.
- Relieve hydraulic pressure or accumulator before maintenance or before loosening hydraulic components.

LBL4181

Part Number: LBL4181
 Description: Do Not Touch Leaks Warning Decal
 Location: Hydraulic Cylinder

⚠ CAUTION

Valve on fuel line must be in the OFF position for towing.

LBL4182

Part Number: LBL4182
 Description: Fuel Line Caution Decal
 Location: Rear Side of Reservoir, Left of Engine

⚠ WARNING

- Cutting hazard at wood splitter wedge – stay clear.
- Keep hands and limbs away from moving parts & log ends.
- Serious injury or death could result if safety precautions are not followed.

LBL4183

Part Number: LBL4183
 Description: Wedge Cutting Hazard Decal
 Location: Beam

⚠ WARNING

PINCH POINT - KEEP AWAY

- To avoid serious injury, keep hands clear of moving cylinder.
- Speeds may change with loads or valve functions.

LBL4184

Part Number: LBL4184
 Description: Pinch Point Warning Decal
 Location: Beam

⚠ CAUTION

USE EXTREME CARE WHEN TILTING THE BEAM. DUE TO THE HEAVY WEIGHT OF THE BEAM, SOME ASSISTANCE MAY BE NEEDED TO INSURE SAFETY AND PREVENT INJURY.

LBL4185

Part Number: LBL4185
 Description: Tilting Beam Decal
 Location: Beam



WARNING: BEFORE OPERATING YOUR LOG SPLITTER, PLEASE FULLY READ AND UNDERSTAND ALL SAFETY, MAINTENANCE, AND ASSEMBLY INSTRUCTIONS OUTLINED IN THIS MANUAL. BECOME FAMILIAR WITH IT FOR YOUR OWN SAFETY. FAILURE TO DO SO MAY CAUSE SERIOUS INJURY AND/OR DEATH. DO NOT ALLOW ANYONE TO OPERATE YOUR LOG SPLITTER WHO HAS NOT READ THIS MANUAL. READ EACH STEP COMPLETELY BEFORE PROCEEDING.

Tools Needed: (2) 9/16" Wrenches, (2) 1/2" Wrenches, (2) 3/4" Wrenches, (1) Flat Screwdriver, (1) pair of Pliers, (1) 10" Adjustable Wrench, (1) Pipe Wrench and (1) Rubber Mallet

ASSEMBLY INSTRUCTIONS

NOTE: The following instructions pertain to both log splitter models, the 22-ton (W2265) and the 27-ton (W2808). Parts listings are included for both.

NOTE: Each log splitter was partially assembled at the factory. Refer to the drawing and parts list should it become necessary to disassemble the unit for repair or replacement of parts.

NOTE: All threaded hose connections need to be taped with Teflon tape supplied in the parts bag before connecting hoses.

1. Remove all components from the crate. Inspect each piece for shipping damage. If any part is damaged, contact your dealer.
2. Remove four conical bearings (4154), two bearing seals (4153), two 3/4" ID washers (4159), two 3/4" slotted nuts (4157) and two cotter pins (4155) from the parts bag. Remove the wheels (4099) from the crate and place on the ground with the valve stem on the bottom side. Place one greased conical bearing into wheel to mate the bearing race. Then place bearing seal onto the wheel and tap into place with a rubber mallet until flush with the hub. Repeat for other wheel.

NOTE: The bearings need to be packed. This can be done by placing two tablespoons of bearing grease into the palm of your hand and with the bearing in the other hand, push the bearing into the grease repeatedly until there is grease throughout the entire bearing. Make sure that all the rollers are greased to ensure long life.

3. With the wheel still facing down, insert the threaded end of spindle (4339) into the wheel from the side with the seal. Flip the wheel over and insert a second conical bearing onto the spindle and into the wheel. Place one 3/4" ID washer on the spindle and secure with 3/4" slotted nut. Turn the nut until it is just snug. Align the hole in the spindle with one of the slots in the nut. Spin the wheel to ensure that it spins freely. If it does not, back the nut out to the next slot. **DO NOT OVERTIGHTEN OR THE BEARINGS WILL FAIL PREMATURELY.** Insert one of the cotter pins into the hole and bend end to hold in place.

4. Attach the wheels to each side of the reservoir (4300) by sliding the end of the spindle into the tubes at the bottom of the reservoir. Make sure that the holes line up as you insert the spindle. Secure in place with two 5/16-18 x 2-1/4" bolts (48300) and two 5/16-18 bi-way locknuts (60G56). Place one bearing cover over the end of the hub and tap with rubber mallet until it is seated against the hub. **DO NOT STRIKE TOO HARD OR YOU WILL DAMAGE THE COVER.** Repeat for the other wheel. See Figure 1.

NOTE: The rest of the assembly is easier done with at least two people.

5. Next, attach kickstand (4306) to tongue (4304) using one 3/8-16 x 3" bolt (4359), two 3/8" flat washers (WF38), one 3/8-16 bi-way locknut (2104), one 3/8" x 2.75" pin (4334) and one hair clip (HAIR-5). Attach the kickstand to the tongue so that it will support the weight of the log splitter as you assemble the rest of the pieces. **DO NOT OVERTIGHTEN - MUST SWING FREELY.** See Figure 2a & 2c.

6. Next, attach the tongue to the reservoir using two 3/8-16 x 3" bolts (4359) and two 3/8-16 bi-way locknuts (2104). Attach travel lock assembly to the tongue using two 3/8-16 x 3" bolts (4359) and two 3/8-16 bi-way locknuts (2104). Position of pin should be toward operator's side. See Figure 2b.

7. Next, remove the 3/4" x 2" pipe nipple (4357) from the parts bag and insert it into the upper hole in the reservoir. Now, remove the screw-on filter (4106) from the parts bag and remove the replaceable filter (4106A) from the cap. Thread the cap onto the nipple at outlet end and tighten until the bottom of the cap faces downward. Thread the filter onto the cap after applying a thin film of oil to the rubber seal to ensure that it does not tear. See Figure 3. For W2808 proceed to step 10.

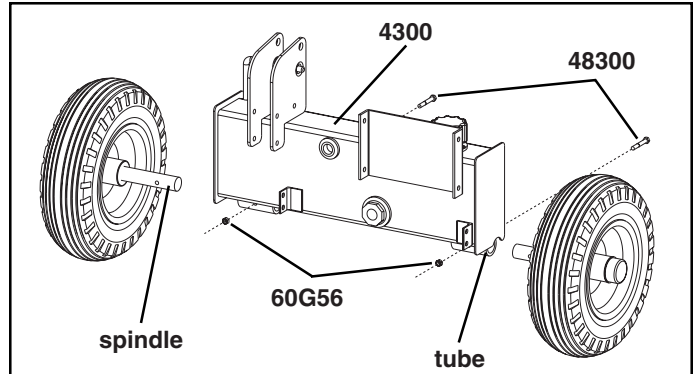

Figure 1

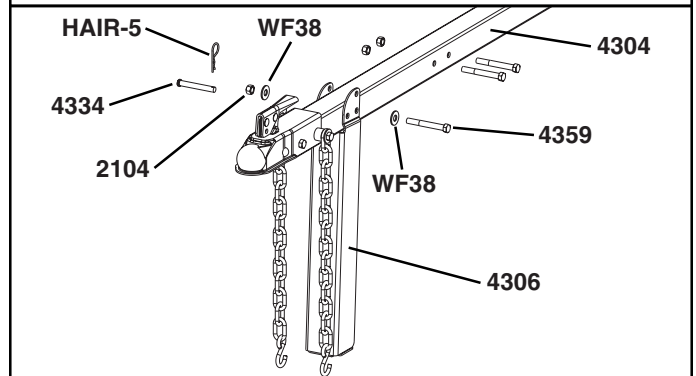

Figure 2a

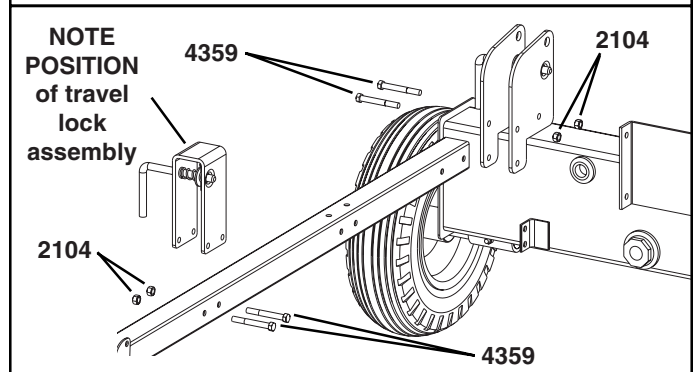

Figure 2b

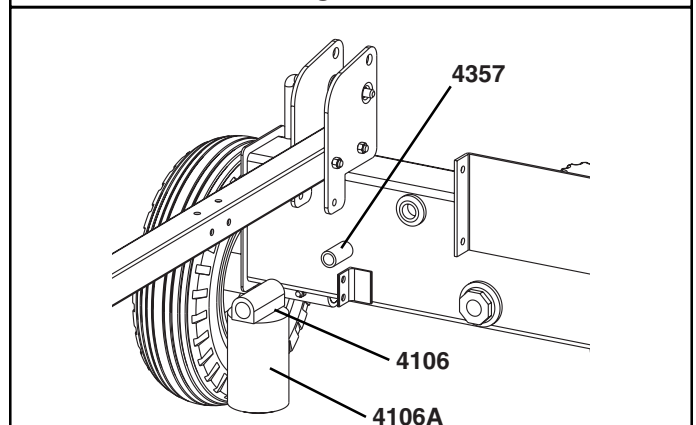

Figure 3

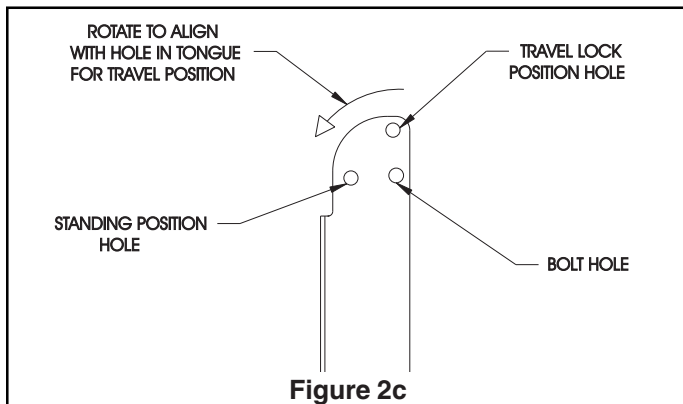

Figure 2c

MODEL W2265 ONLY

8. Remove the 90 degree street elbow (4122) and the 1" barbed coupler (4160) and insert the street elbow first into the suction screen (4307) that has already been assembled into the reservoir. Tighten the elbow until it faces to the right or engine side of the log splitter when looking at the log splitter from the front. Then insert the 1" barbed coupler into the street elbow and tighten. **See Figure 4.**
9. Assemble the pre-assembled engine assembly onto the reservoir as shown using four 3/8-16 x 1" bolts (2102) and four 3/8-16 bi-way locknuts (2104). Attach the suction hose (4327) between the 1" barbed coupler and the hydraulic pump (4344) using two hose clamps (4169). **See Figure 4.** Go to Step 12.

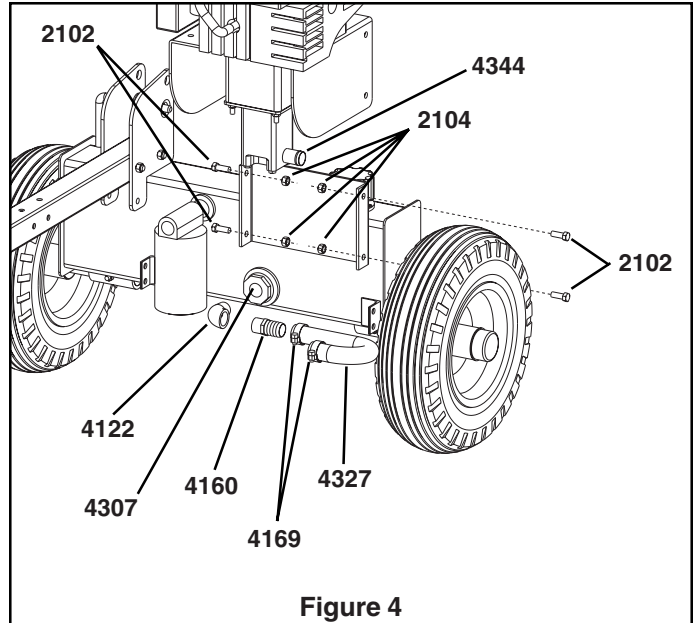

Figure 4

MODEL W2808 ONLY

10. Remove the 1" barbed coupler (4160) from the parts bag and assemble into the suction screen (4307) that has been installed at the factory. Tighten. **See Figure 5.**
11. Assemble the engine plate (4371) onto the reservoir using four 3/8-16 x 1" bolts (2102) and four 3/8-16 bi-way locknuts (2104). Next, assemble the engine assembly to the plate using four 5/16-18 x 1-1/2" (48156) and four 5/18-18 bi-way locknuts (60G56). Attach the suction hose (4372) using two hose clamps (4169) between the 1" barbed coupler and the hydraulic pump (4323). **See Figure 5.**

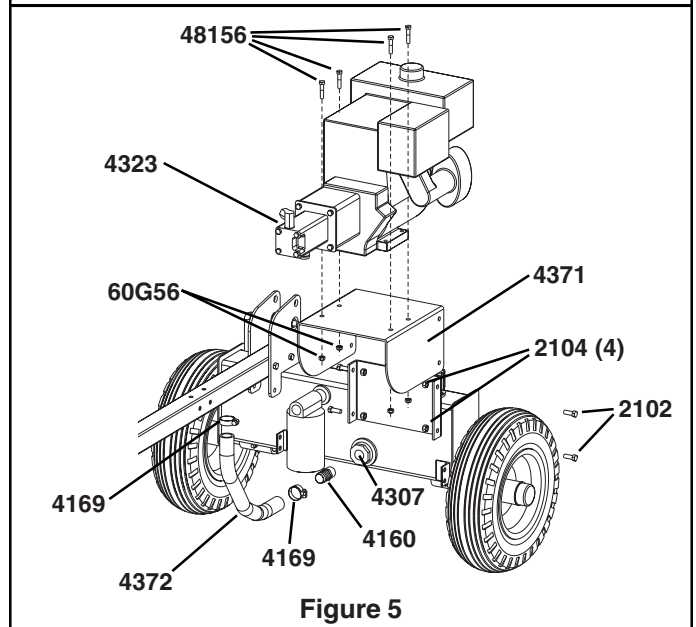

Figure 5

NOTE: At least two people are required to lift and assemble the beam to the reservoir.

12. Remove the beam and stand it upright on the foot as it would be in use. Roll the reservoir into position and rotate the reservoir with the tongue until the holes line up to insert the 5/8" x 4" pivot pin (4337). Insert a cotter pin (4155) into hole in pin and bend with pliers to secure. **See Figure 6.**

13. Rotate the beam until it is horizontal. Install the stripper bars (4314) facing upward using four 1/2-13 x 1" bolts (4363) and four 1/2-13 bi-way locknuts (4117). Install the brush guard (4326) using four 3/8-16 x 1" bolts (2102) and four 3/8-16 bi-way locknuts (2104). **See Figure 7.**

14. Remove the high pressure hoses from the parts box. Install a 60" hose (4210) from the top of the valve (4100) to the filter (4106). Route the hose over the top of the tongue and under the beam. Next, remove the inlet hose (4210 for W2265; 60" long) or (4209 for W2808; 48" long) and install between the pump outlet and the bottom of the valve also routing over the tongue and under the beam.

15. Move control valve handle to operation position. Remove 1/4" pin (4190) and 1/16" cotter pin (4189) from parts bag and insert pin through hole in control valve handle and secure with cotter pin. **See Figure 8.**

16. Fill the reservoir with hydraulic oil but do not overflow. Fill the engine with oil and gas as required. Start the engine and operate the log splitter running the wedge to the end of the beam and back until it operates smoothly. Also, check for leaks under pressure. Tighten as needed. Check level of fluid in reservoir. Ensure that oil level is on the dipstick; if not, add oil as needed. If the log splitter will not operate smoothly, contact your dealer.

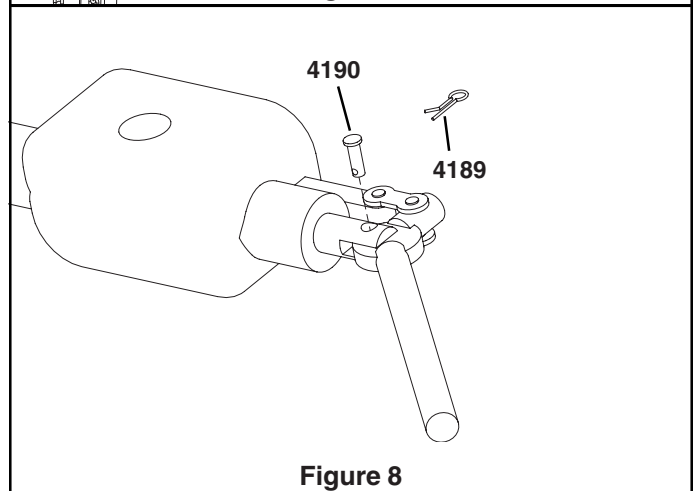
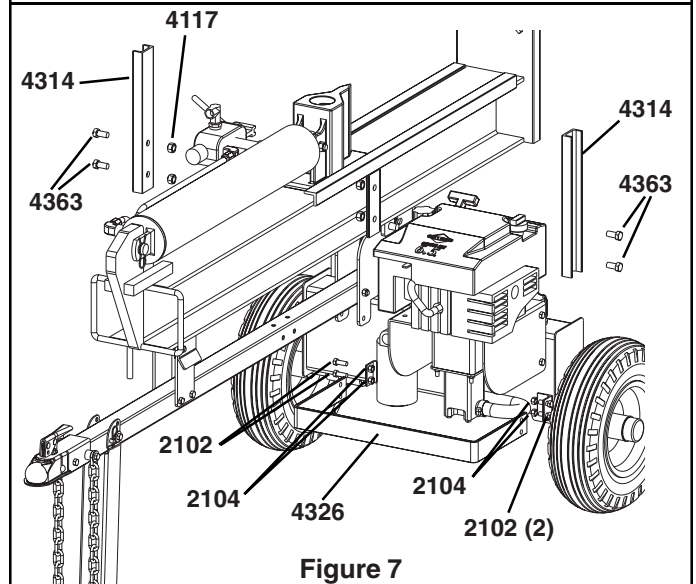
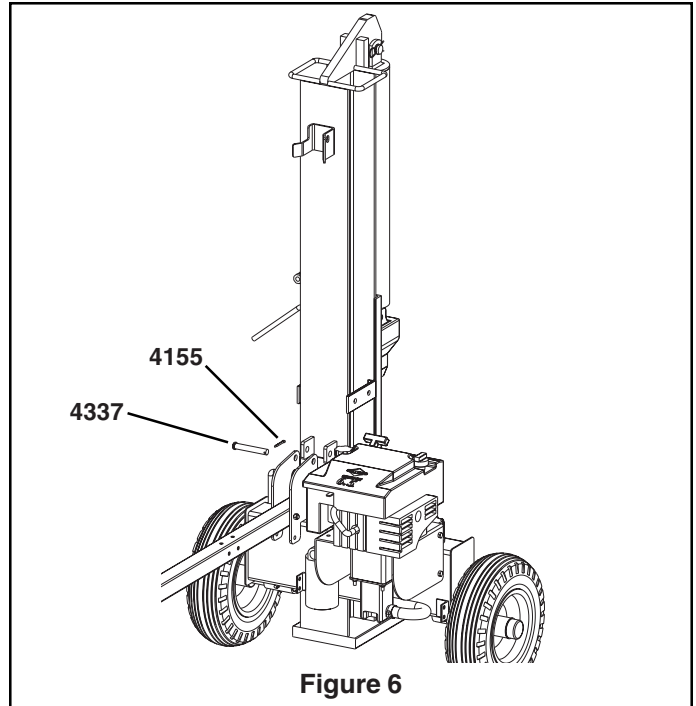

STARTING

IMPORTANT: The engine and hydraulic reservoir are shipped without oil. See the Engine Operator's Manual packed with your log splitter for the type of crankcase oil, fuel, etc. The engine manufacturer recommends lead-free gasoline only.



CAUTION: DO NOT START OR RUN THE ENGINE WITHOUT OIL IN THE HYDRAULIC RESERVOIR AND ENGINE.

1. The hydraulic reservoir should be filled with an SAE 30 hydraulic oil (if temperature will be above 50 degrees when operating unit) and SAE 20 hydraulic oil (if temperature will be between 32 degrees and 50 degrees). If hydraulic oil is difficult to obtain, automatic transmission fluid can be substituted and should be used instead of hydraulic oil when temperatures are below 32 degrees F. Use only clean oil and take care to prevent dirt from entering the hydraulic reservoir.

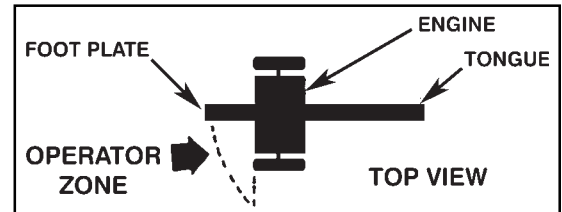

ENGINE OIL RECOMMENDATIONS

1. For temperatures above 40 degrees F use an SAE 30W oil. Using multigrade oil may increase oil consumption. Using SAE 30W oil below 40 degrees F will result in hard starting and possible engine bore damage. For temperatures below 40 degrees F use an SAE 10W-30 or SAE 5W-30 oil. Oil capacity is about 1-1/2 quarts (48 ounces or 1.4 liters). Refer to Engine Operator's Manual for further information.

DIRECTIONS FOR FILLING HYDRAULIC SYSTEM

1. Fill the hydraulic reservoir with at least three gallons of hydraulic fluid. After the hydraulic reservoir and the engine crankcase are filled with oil, start the engine. The hydraulic pump should prime itself. With the engine running, move the hydraulic valve lever toward the wedge. This will cause the cylinder to extend and expel air. When the cylinder is fully extended, retract it. Repeat this procedure several times. An erratic movement of the cylinder indicates that there is still air in the system.

NOTE: If the reservoir is overfilled, it will tend to expel oil from the breather cap when the cylinder is retracted.

STARTING INSTRUCTIONS

1. Move the throttle lever to "**FAST**". Always operate the engine with throttle lever in the "**FAST**" position.
2. Move choke control lever to "**CHOKE**" position.
3. Grasp rope handle and pull slowly until resistance is felt. Then pull rapidly to start engine and avoid engine kickback.
4. Allow the engine to warm up. If operating in warm weather, move the choke control lever toward "**RUN**" a short distance at a time over several seconds. For cold weather operation do this procedure over several minutes. Operate with choke lever in the "**RUN**" position.
5. To stop engine, move the throttle lever to the "**STOP**" position.

NOTE: The maximum governed speed on the engine is preset at the factory at 3600 RPM no load speed. When splitting wood, the throttle should be set at the maximum setting to develop the horsepower required for the pump.

TOWING

1. The log splitter is equipped with high speed road tires, a Class II coupler (1-7/8" diameter ball required) and a safety chain. Before towing, the safety chain must be secured to the hitch or bumper of the vehicle and the kickstand rotated to the road position. Local regulations should be checked regarding licensing, lights, towing, etc. See also Towing Safety in the Safety information section of this manual.

OPERATION



WARNING: ALWAYS WEAR SAFETY GLASSES DURING OPERATION!



WARNING: KEEP HANDS AND FEET CLEAR OF RAM, STRIPPER CHANNELS AND FOOT PLATE AT ALL TIMES.



WARNING: DO NOT OPERATE LOG SPLITTER WITH LESS THAN 1/2" OF HYDRAULIC OIL IN RESERVOIR.

1. Set up the log splitter in a clear, level area and block the wheels. Make sure that the suction port on the reservoir is always on the lower side of the log splitter.
2. Place a log on the beam against the foot plate. Make sure that the log is securely on the foot plate and up against the beam.
3. Depress the control valve handle so that the cylinder will drive the wedge into the log. Extend the cylinder until the log splits or to the end of its stroke. If the log has not completely split after the cylinder has reached the end of its extension, retract the cylinder.

IMPORTANT: Leaving the valve in the "actuate" position at the end of the stroke may damage the pump. Always use extra care when splitting logs with ends not square.

NOTE: For operation in wooded areas, obtain a spark arrestor for the exhaust system. See the Engine Operator's Manual and check with your authorized Tecumseh or Briggs & Stratton service center. See also Fire Prevention in the Safety information section of this manual.

IMPORTANT: To extend the life of the hydraulic cylinder, avoid "bottoming out" wedge plate to the foot piece. To conform with industry safety recommendations, the wedge stops two inches from the end of the stroke.

MAINTENANCE

1. Consult the operating and maintenance instructions of the Engine Operator's Manual for engine care and maintenance.
2. Always check the oil level of the hydraulic reservoir before operation. Operating the log splitter without an adequate oil supply will cause severe damage to the hydraulic pump.
3. Change the oil filter after the first 25 hours of operation. Thereafter, change the oil filter every 100 hours or seasonally, whichever comes first.
4. If the wedge becomes dull or nicked, it can be removed and sharpened. While the log splitter is in the horizontal position, remove the 1/2" x 3-1/2" bolt (4362) that connects the wedge to the hydraulic cylinder. Carefully rotate the hydraulic cylinder, take special care not to damage the control valve. The wedge can now be removed and sharpened.
5. Refer to the Repair and Maintenance Safety section of this manual.
6. All replacement parts must meet manufacturer's specifications.
7. Check air pressure of tires before each use. Maintain pressure between 20 psi and 30 psi.
8. Grease wheel bearings annually.

STORAGE

1. Rotate the beam to the vertical position after the log splitter has been moved to its storage location. Ensure that the locking pin for the vertical position has been fully engaged.
2. While a second person balances the beam vertically, unbolt the tongue from the reservoir. Save the nuts and bolts. Rotate the tongue 90 degrees and stand it on the end that was previously bolted the reservoir. Re-install the two nuts and bolts that were removed in Step 1. **Refer to Figure 9.**
3. To return the unit to its functional state, follow the Steps in reverse order.

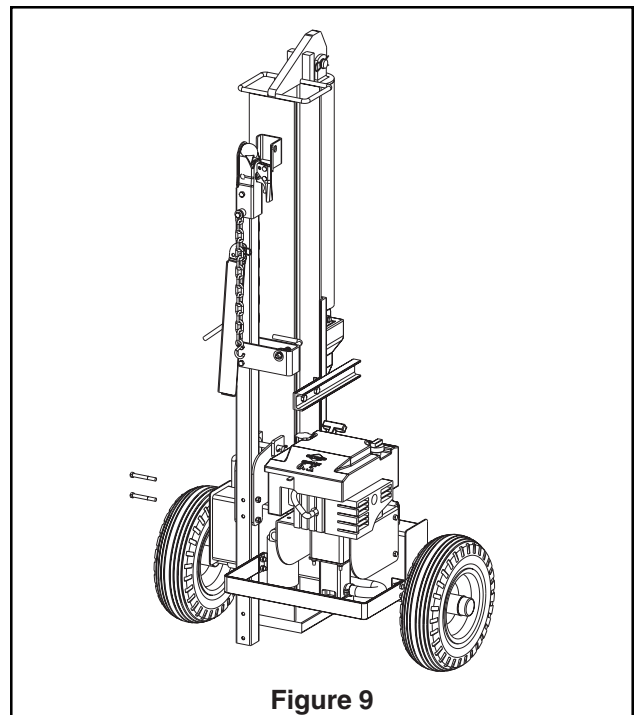
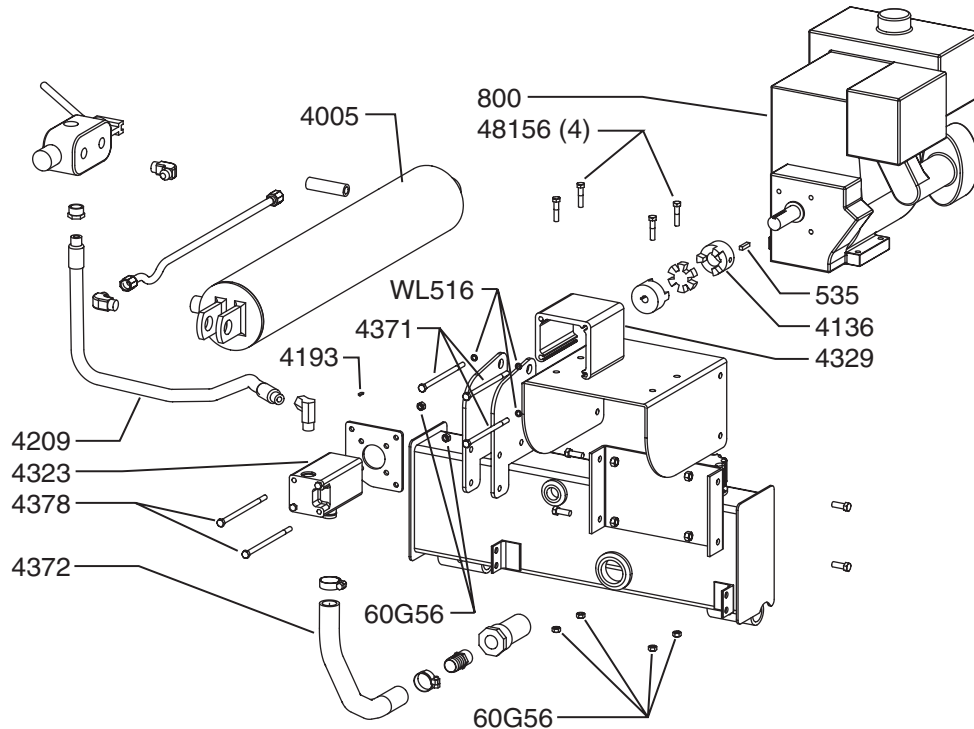
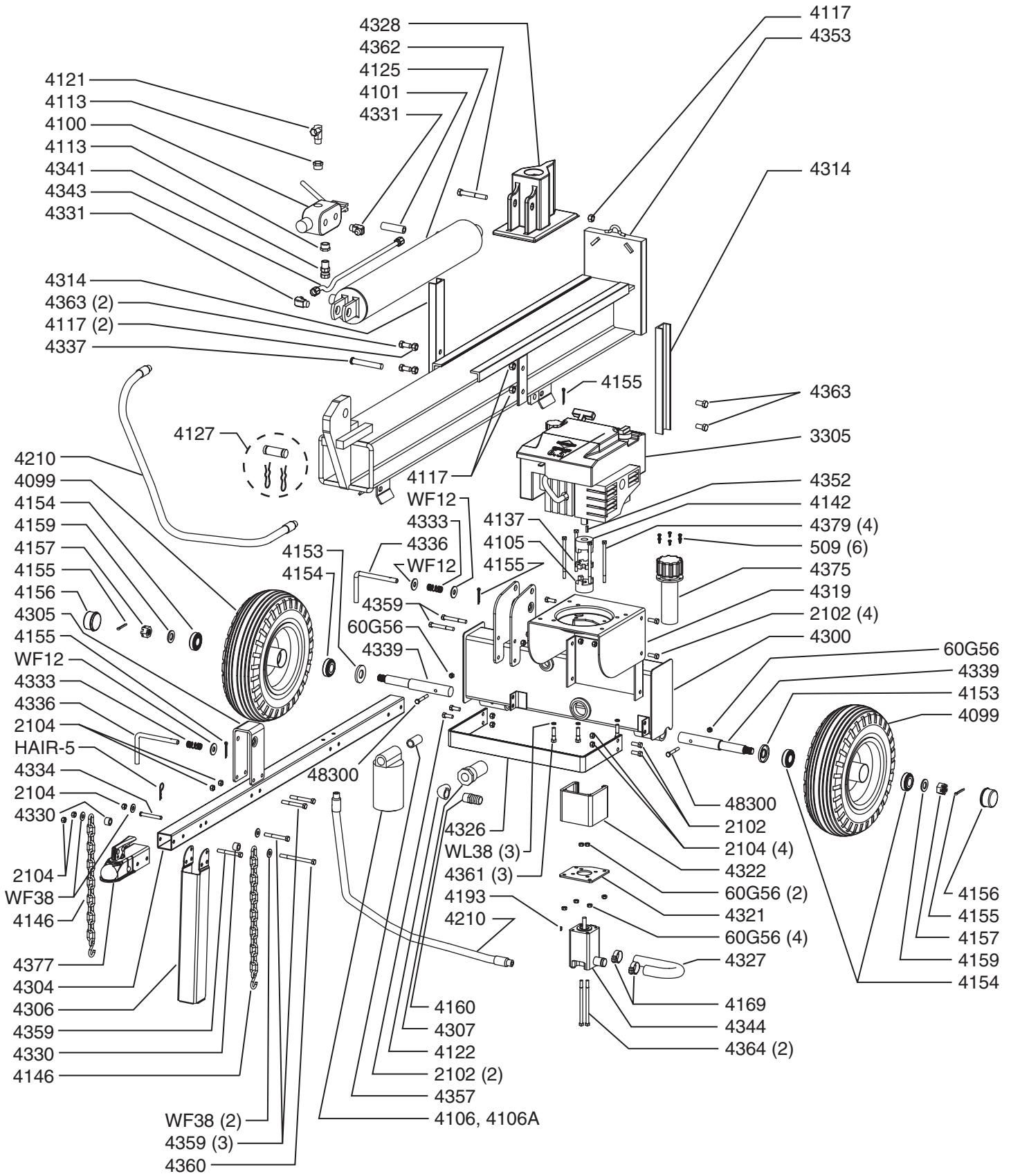

Figure 9

Earthquake[®] LOG SPLITTER NOTES

Earthquake[®] 8-HP LOG SPLITTER PARTS EXPLOSION





MODEL W2265 & W2808

<u>Part No.</u>	<u>Description</u>	<u>Qty.</u>	<u>Part No.</u>	<u>Description</u>	<u>Qty.</u>
60G56	Locknut, Bi-way, 5/16"	8	4314	Stripper Bar, Removable	2
509	Bolt, Slotted HWH, 1/4-20 x 1/2"	6	4319	Engine Plate, 6.5-hp	1
535	Key, 1/4" x 1", 8-hp	1	4321	Mount Adapter Plate, Hydraulic Pump	1
800	Engine-Tecumseh, 8-hp	1	4322	Pump Spacer, Alum. Extruded, 6.5-hp	1
2102	Bolt, HH, 3/8-16 x 1"	8	4323	Hydraulic Pump, 16 GPM, 8-hp	1
2104	Nut, Bi-Way Hex, 3/8"	15	4326	Brush Guard, Removable	1
3305	Engine-Briggs Quantum, 6.5-hp	1	4327	Hose, Suction, 6.5-hp	1
4005	Hydraulic Cylinder, 4" x 24", 8-hp	1	4328	Wedge	1
4099	Wheel, High Speed	2	4330	Spacer, Chain	2
4100	Control Valve, 3-way	1	4331	Fitting, 1/2" to 1/2", 90 deg.	2
4101	Nipple-Pipe, 1/2" x 3"	1	4333	Spring, Spring Pin, 1-3/4"	2
4105	Coupler, Lov-joy, 1/2" ID	1	4334	Pin, Jack Stand, 3/8" x 2-3/4"	1
4106	Filter Kit, Hydraulic, Complete	1	4336	Spring Pin, 1/2"	2
4106A	Filter Only	1	4337	Pin, Pivot, 5/8" x 4"	1
4113	Reducer, 3/4" to 1/2"	2	4339	Spindle, Drilled	2
4117	Nut, 1/2" Nyloc	5	4341	Swivel Adapter, 1/2" x 1/2", 6.5-hp	1
4121	Coupler, 90 deg. Swivel, 1/2" PT, 6.5-hp	1	4343	Hydraulic Line, Steel	1
4121	Coupler, 90 deg. Swivel, 1/2" PT, 8-hp	2	4344	Hydraulic Pump, 11 GPM, 6.5-hp	1
4122	Fitting, Pipe, 3/4", 90°, 6.5-hp	1	4352	Key, Square, 3/16" x 5/8", 6.5-hp	1
4125	Hydraulic Cylinder, 4" x 24", 6.5-hp	1	4353	Beam	1
4127	Clevis Pin Assembly, 2-7/8"	1	4357	Nipple, Pipe, 3/4" x 2"	1
4136	Coupler, Lov-joy, 1" ID, 8-hp	1	4359	Bolt, HHCS, 3/8-16 x 3"	6
4137	Coupler, Spider	1	4360	Bolt, HHCS, 3/8-16 x 4-1/2"	1
4142	Coupler, Lov-joy, 3/4" ID, 6.5-hp	1	4361	Bolt, Self Thrd, 3/8-16 x 1-1/2", 6.5-hp	3
4146	Chain Assembly	2	4362	Bolt, HHCS, 1/2-13 x 3-1/2"	1
4153	Seal, Bearing	2	4363	Bolt, HHCS, 1/2-13 x 1"	4
4154	Bearing, 1" Conical	4	4364	Bolt, HHCS, 5/16-18 x 5-1/2", 6.5-hp	2
4155	Cotter Pin, 5/32" x 1-1/2"	5	4371	Engine Plate, 8-hp	3
4156	Cover, Bearing	2	4372	Hose, Suction, 8-hp	1
4157	Retainer Nut, High Speed Spindle, 3/4"	2	4374	Guard, Pump Spacer, 8-hp	1
4159	Washer, 3/4" ID	2	4375	Breather Cap w/ Dipstick & Screen	1
4160	Coupler, 3/4" x 1" Barbed	1	4377	Coupler, Trailer 1-7/8" Ball	1
4169	Hose Clamp, 1-3/4"	2	4378	Bolt, HHCS, 5/16-18 x 6", 8-hp	2
4193	Key-Half Moon	1	4379	Bolt, HHCS, 5/16-24 x 5", 6.5-hp	4
4209	Hydraulic Hose, 48", 8-hp	1	4379	Bolt, HHCS, 5/16-24 x 5", 8-hp	3
4210	Hydraulic Hose, 60", 6.5-hp	2	48156	Bolt, HHCS, 5/16-18 x 1-1/2", 8-hp	4
4210	Hydraulic Hose, 60", 8-hp	1	48300	Bolt, HHCS, 5/16-18 x 2-1/4"	2
4300	Hydraulic Tank (Reservoir)	1	HAIR-5	Hair Pin, 5/16"	1
4304	Tongue	1	WF12	Flat Washer, 1/2"	3
4305	Horizontal Beam Support	1	WF38	Flat Washer, 3/8"	4
4306	Kick Stand	1	WL38	Lockwasher, 3/8", 6.5-hp	3
4307	Suction Screen, 3/4" x 1-1/2" x 4"	1	WL516	Lockwasher, 5/16", 8-hp	3

Earthquake LOG SPLITTER SPECIFICATIONS

	MODEL W2265	MODEL W2808
MAXIMUM SPLITTING FORCE	22-tons	27-tons
ENGINE	6.5-hp Briggs & Stratton	8-hp Briggs & Stratton
CYLINDER	4" dia. x 24" stroke	4.5" dia. x 24" stroke
VALVE	auto-return	auto-return
PUMP	2-stage 11 gpm	2-stage 16 gpm
MAXIMUM LOG LENGTH	26"	26"
CYCLE TIME	14 seconds	16 seconds
TIRES	4.00 x 15" high-speed road	4.00 x 15" high-speed road
BALL HITCH	1-7/8" dia.	1-7/8" dia.
WEDGE	7" high	7" high
BEAM SIZE	6" x 6"	6" x 6"
RESERVOIR CAPACITY	3.75 gallons	4 gallons
FILTER	replaceable spin-on & replaceable in-tank screen	replaceable spin-on & replaceable in-tank screen
HEIGHT	70.25" vertical position 37" horizontal position	70.25" vertical position 37" horizontal position
LENGTH	84"/33" storage	84"/33" storage
WIDTH	39"	39"
SHIPPING WEIGHT	521 lbs.	541 lbs.

The logo for Earthquake, featuring the word "Earthquake" in a bold, white, sans-serif font with a registered trademark symbol, set against a black background with a green border.

Ardisam, Inc.
1690 Elm Street, Cumberland, Wisconsin 54829
(715)822-2415 • Fax (715)822-4180
www.ardisam.com