

GENERAC

The Reliable Ones

10000EXL

Portable Generator Owner's Manual

- ⚠ Danger:** This generator is designed for outdoor use only. Do not use this generator inside any building or enclosure including the generator compartment of a recreational vehicle (RV). Fire or an explosion may result. No user performed modifications, including venting of exhaust and/or cooling ventilation, will eliminate the danger. Also, allow at least two feet of clearance on all sides of the generator even while operating the unit outdoors.
- ⚠ Danger:** If this unit is used for backup power in the event of a utility power failure, the following step must be taken: Before connecting the generator to an electrical system, open the main circuit breaker or main switch serving the system, to isolate the generator system from the electric utility. Failure to isolate the generator and utility systems may result in damage to the generator and may also result in injury or death to electric utility workers, due to a backfeed of electrical energy.

The Emission Control System for this generator is warranted for standards set by the Environmental Protection Agency.

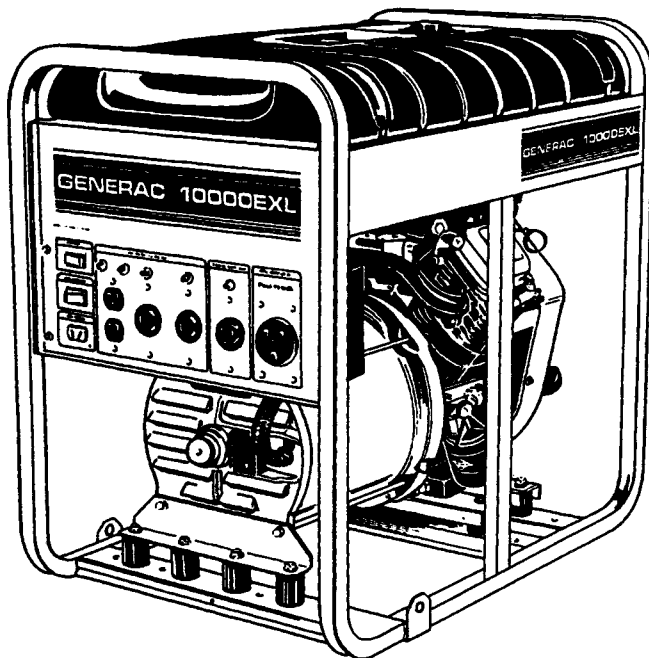

**Problems?
Questions?**
Before taking your unit
back to the store,
call the generator
helpline at
1-800-270-1408
M-F 8-5 CST

Model No. 9801-1 (10000 Watt AC Generator) Manual No. 96023 Revision 3 (7/30/98)

- ⚠** This symbol points out important safety instructions, which, if not followed, could endanger the personal safety and/or property of yourself and others. Read and follow all instructions in the manual before attempting to operate this unit.



EQUIPMENT DESCRIPTION

This generator is an engine-driven, revolving field, alternating current (AC) generator. It was designed to supply electrical power for operating compatible electrical lighting, appliance, tool and motor loads. This manual contains information for a generator that operates 120 and/or 240 volts, single phase, 60Hz devices that require up to 10000 watts (10 kW) of power that pull up to 83.3 amps at 120 volts or 41.7 amps at 240 volts.

CAUTION: Do not exceed the generator's wattage/amperage capacity. Add up the rated watts of all devices you are connecting to generator receptacles at one time. This total should not be greater than 10000 watts for this generator. In most cases rated watts of the electrical device can be found on the device nameplate. If the device nameplate gives only volts and amps, multiply volts times amps to obtain watts (volts x amps = watts).

The generator's revolving field is driven at about 3600 rpm by a twin-cylinder engine.

Every effort has been expended to make sure that the information in this manual is both accurate and current. However, Generac reserves the right to change, alter or otherwise improve the product at any time without prior notice.

DANGER: Do not tamper with engine governed speed. High operating speeds are dangerous and increase the risk of personal injury or damage to equipment. The generator supplies correctly rated frequency and voltage only when running at proper governed speed. Incorrect frequency and/or voltage can damage some connected electrical loads. Operating at excessively low speeds imposes a heavy load and, when adequate engine power is not available, may shorten engine life.

Model & Serial Numbers

In the spaces provided below, insert the Model and Serial numbers of your generator. Retain these numbers for future reference. You can find Model and Serial numbers on the generator data plate, along with other important information.

Model Number _____

Serial Number _____



WARNING:



The engine exhaust from this product contains chemicals known to the State of California to cause cancer, birth defects, or other reproductive harm.

SAFETY RULES

This generator set was designed and manufactured for specific applications. Do not attempt to modify the unit or use it for any application it was not designed for. If you have any questions about your generator's application, ask your Dealer/Distributor or consult the factory.

The manufacturer could not possibly anticipate every circumstance that might involve a hazard. For that reason warnings in the Manual and on tags or decals affixed to the unit are not all-inclusive. If you intend to handle, operate or service the unit by a procedure or method not specifically recommended by the manufacturer, first make sure that such a procedure or method will not render this equipment unsafe or pose a threat to you and others.

Read this manual carefully and become familiar with your generator set. Know its applications, its limitations and any hazards involved.

- The generator produces a very powerful voltage that can cause extremely dangerous electrical shock. Avoid contact with bare wires, terminals, etc. Never permit any unqualified person to operate or service the generator.
- Never handle any kind of electrical cord or device while standing in water, while barefoot or while hands or feet are wet.
- The National Electric Code requires the frame and external electrically conductive parts of generator be properly connected to an approved earth ground. Local electrical codes may also require proper grounding of the generator. Consult with a local electrician for grounding requirements in your area.
- Use a ground fault circuit interrupter in any damp or highly conductive area (such as metal decking or steel work).
- Do not use any worn, bare, frayed or otherwise damaged electrical cord sets with the generator.
- Operate generator only on level surfaces and where it will not be exposed to excessive moisture, dirt, dust or corrosive vapors.

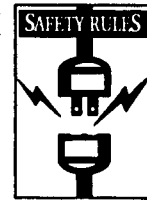

- Gasoline is highly **FLAMMABLE** and its vapors are **EXPLOSIVE**. Do not permit smoking, open flames, sparks or heat in the vicinity while handling gasoline. Avoid spilling gasoline on a hot engine. Comply with all regulations requiring storage and handling of gasoline.
- Do not overfill the fuel tank. Always allow room for fuel expansion. If tank is overfilled, fuel can overflow onto a hot engine and cause **FIRE** or an **EXPLOSION**.
- Never store the generator with fuel in the tank where gasoline vapors might reach an open flame, spark or pilot light (as on a furnace, water heater or clothes dryer). **FIRE** or an **EXPLOSION** might result.
- Generator exhaust gases contain **DEADLY** carbon monoxide gas. Operate this equipment only in the open air where adequate ventilation is available.
- The engine-generator requires an adequate flow of cooling air for its continued proper operation. Never operate the unit inside any room or enclosure where the free flow of cooling air into and out of the unit might be obstructed. Allow at least 2 feet of clearance on all sides of generator..
- Never start, or stop, the engine-generator with electrical loads connected to receptacles with the connected devices turned **ON**. Start the engine and let it stabilize before connecting electrical loads. Disconnect all electrical loads before shutting down the generator.
- Do not insert any object through cooling slots of the engine-generator. You could damage the unit or injure yourself.
- Never operate the generator: (a) in rain; (b) in any enclosed compartment; (c) if engine speed changes; (d) if connected electrical devices overheat; (e) if electrical output is lost; (f) if engine or generator sparks; (g) if flame or smoke is observed while unit is running; (h) if unit vibrates excessively.

GROUNDING THE GENERATOR

The National Electric Code requires the frame and external electrically conductive parts of the generator be properly connected to approved earth ground. Local electrical codes may also require proper grounding of the unit. For this purpose, a **GROUND LUG** (Figure 1) is provided on the cradle.

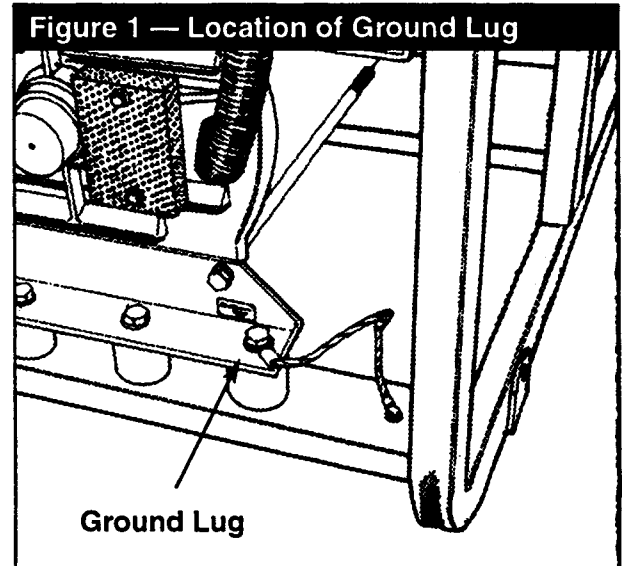

Generally, connecting a No. 12 AWG (American Wire Gauge) stranded copper wire to the ground lug screw and to an earth-driven copper or brass grounding rod (electrode) provides adequate protection against electrical shock. However, local codes may vary widely. Consult with a local electrician for grounding requirements in your area. Be sure to keep the ground wire attached while you connect the electrode.

Properly grounding the generator helps prevent electrical shock if ground fault conditions exist in the generator or in connected electrical devices. Proper grounding also helps dissipate static electricity, which often builds up in ungrounded devices.

Installing Battery

You must purchase and install a 12 volt DC battery (Y50-N18L-A3 Motorcycle Battery). The battery should be serviced with electrolyte fluid and fully charged prior to installation. Install the battery as follows:

- Locate the battery fasteners and wires shipped loose in the carton. You should have 2-7" bolts, 2-lock washers, 2-washers, 1-battery bracket and 2-hex nuts. In addition you should have one M8 x 1.25 inch bolt to attach the black battery cable to the engine.
- Set battery onto tray.
- Secure battery with the 2-7" bolts, 2-lock washers, 2-washers, 1-battery bracket and 2-hex nuts. See figure 2 below.

Figure 2 — Secure Battery

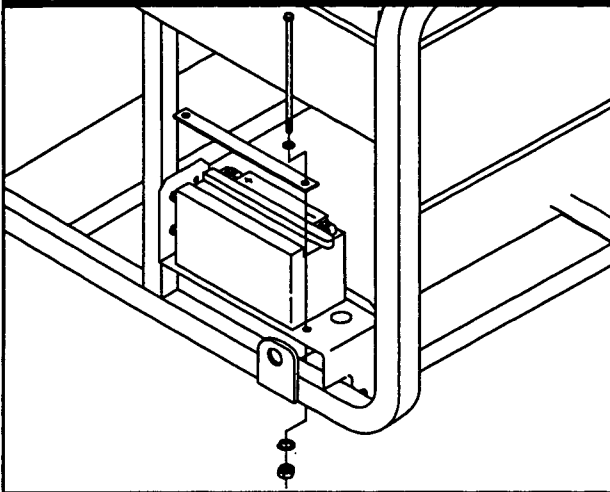

- Connect the back battery cable to the engine using the M8 x 1.25 inch bolt. See location in figure 3 below.

Figure 3 — Attach Black Battery Cable to Engine

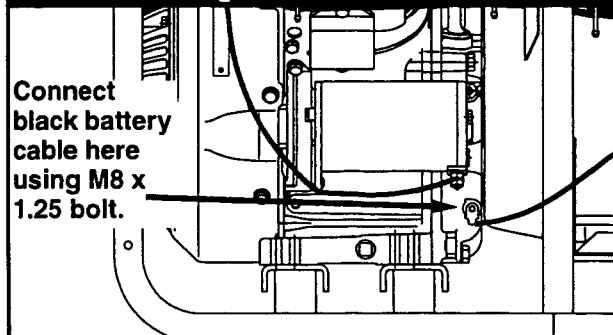

CAUTION: Be sure the black cable is connected to the engine mount and not the frame. You could damage the ground wire.

- Connect the other end of the black battery cable to the **negative (-)** battery post.
- Connect the red battery cable to the engine starter switch. See figure 4 below.

Figure 4 — Connect Red Battery Cable to Engine Starter Switch

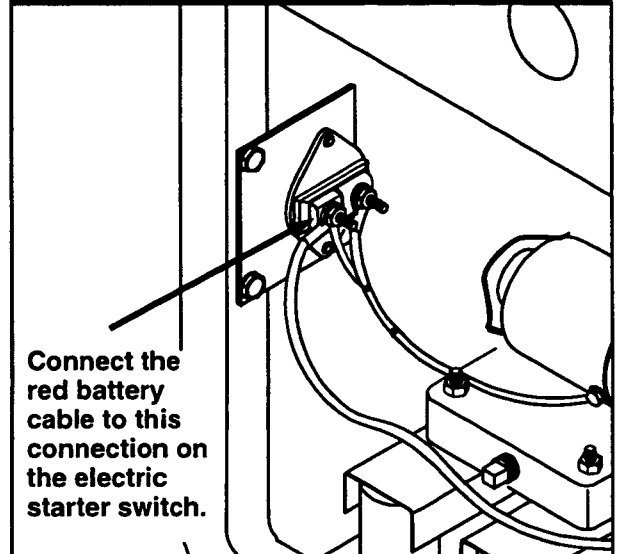

- Connect the red battery cable from the electric starter switch to **positive (+)** post on the battery.

Figure 5 — Overview of Battery Connections

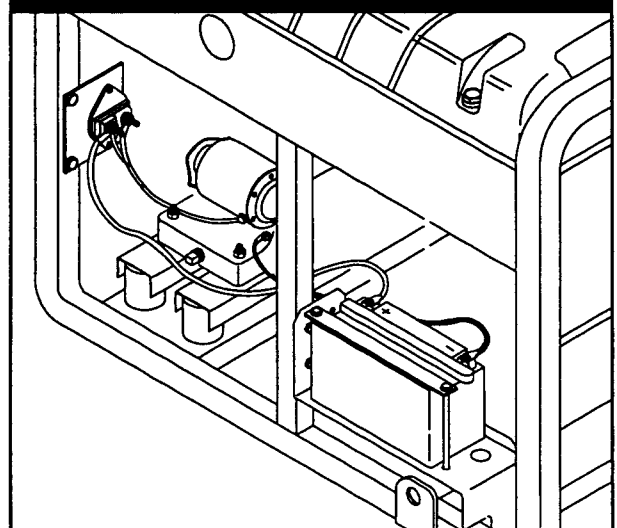



Know Your Generator

Read this owner's manual and safety rules before operating your generator. Compare the illustrations with your generator to familiarize yourself with the locations of various controls and adjustments.

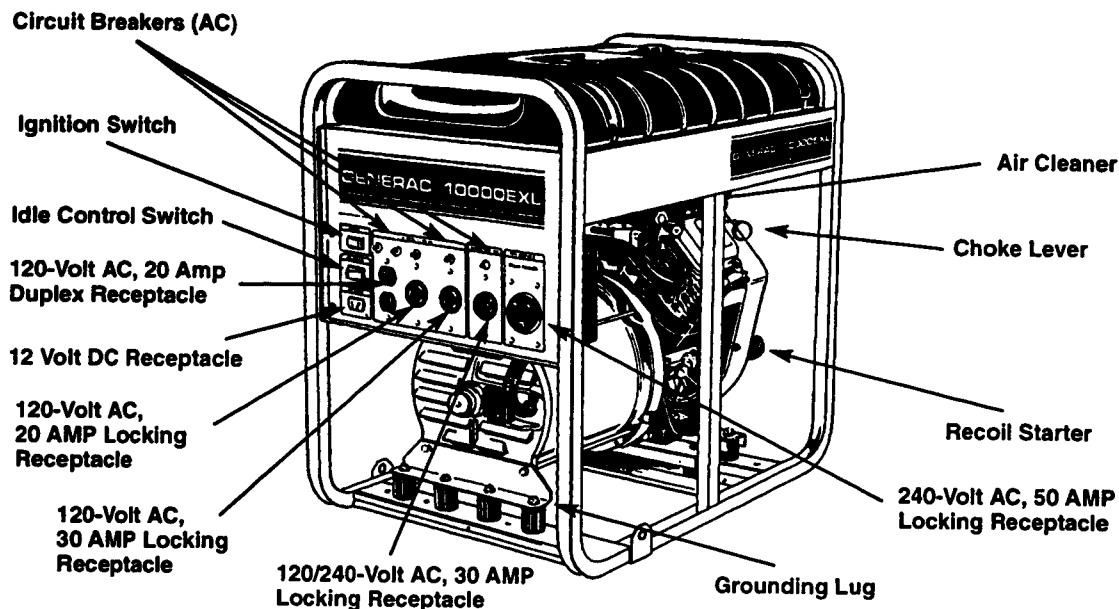

12 Volt DC Receptacle — Use this receptacle with battery charge cables to charge a 12 volt battery.

120-Volt AC, 20 AMP Duplex Receptacle — May be used to supply electrical power for the operation of 120 volt AC, single phase, 60 Hz, AC electrical lighting, appliance, tool and motor loads.

120-Volt AC, 20 AMP Locking Receptacle — May be used to supply electrical power for the operation of 120 volts at 20 amps AC, single phase, 60 Hz, AC electrical lighting, appliance, tool and motor loads.

120-Volt AC, 30 AMP Locking Receptacle — May be used to supply electrical power for the operation of 120 volts at 30 amps AC, single phase, 60 Hz, AC electrical lighting, appliance, tool and motor loads.

120/240-Volt AC, 30 AMP Locking Receptacle — May be used to supply electrical power for the operation of 120 and/or 240 volts at 30 amps AC, single phase, 60 Hz, AC electrical lighting, appliance, tool and motor loads.

240-Volt AC, 50 AMP Locking Receptacle — May be used to supply electrical power for the operation of 240 volts at 41.7 amps AC, single phase, 60 Hz, AC electrical loads.

Air Cleaner — Uses a dry type filter element and foam pre-cleaner to limit the amount of dirt and dust that gets in the engine.

Choke lever — Used when starting a cold engine.

Circuit Breakers (AC) — Each receptacle except the 50 amp receptacle is provided with a circuit breaker to protect the generator against electrical overload. Breakers are "push to reset" type.

Grounding Lug — Use this connection to properly ground the generator. See "Grounding the Generator" on Page 3.

Idle Control Switch — The idle control runs the engine at normal (high) speeds when there is a load present and runs the engine at idle (low) speeds when a load is not present. This feature greatly improves fuel economy, extends the life of the engine, and reduces engine noise.

Ignition Switch — Must be set **On** (—) position to start generator. To turn off generator, set switch to the **Stop** (o) position.

Recoil starter — Used for starting the engine.

Spark Arrestor Muffler (not shown) — Exhaust muffler lowers engine noise and is equipped with a spark arrestor screen.

BEFORE STARTING THE ENGINE

Perform the following tasks before starting the generator:

■ Add Engine Oil

Note: When adding oil to the engine crankcase in the future, use only high quality detergent oil rated with API service classification SF and SG rated SAE 30 weight. Use no special additives. **DO NOT USE SAE 10W-40.**

Select the oil's viscosity grade according to your expected operating temperature.

| | | |
|--------|----------|--------|
| colder | ← 32°F → | warmer |
| 5W-30 | | SAE 30 |

Although multi-viscosity oils (5W30, 10W30, etc.) improve starting in cold weather, these multi-viscosity oils will result in increased oil consumption when used above 32°F. Check your engine oil level more frequently to avoid possible damage from running low on oil.

To add oil to the generator:

The oil fill on your engine is partially blocked by the fuel tank. Please use the oil fill nozzle provided and follow the instructions below to properly add oil to the engine.

- 1.) Remove paper seal on the oil fill nozzle (P/N B3518).
- 2.) Remove red cap on the oil fill nozzle.
- 3.) Using a scissors, cut the tip off the oil fill nozzle.
Note: Cut no more than 1/4" from the tip.
- 4.) Place oil fill nozzle on oil bottle.
- 5.) Clean around oil fill cap and remove it.
- 6.) Remove oil dipstick, wipe clean and reinsert in engine.
- 7.) Fill engine with oil till it reaches the full mark on the dipstick. Stop occasionally to check oil level. Do not overfill.
- 8.) Install oil dipstick.
- 9.) Install oil fill cap. Hand tighten securely.

CAUTION: Any attempt to crank or start the engine before it has been properly serviced with the recommended oil results in an engine failure.

NOTE: The generator's revolving field rides on a pre-lubricated and sealed ball bearing that requires no additional lubrication for the life of the bearing.

Figure 6 — Using the Oil Fill Nozzle

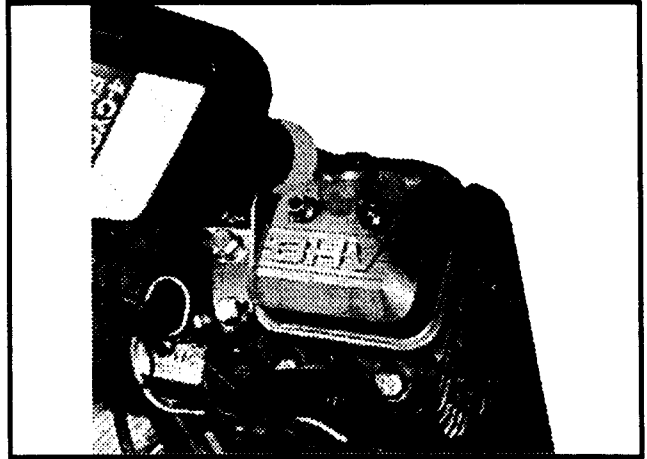

■ Add Fuel

DANGER: NEVER fill fuel tank indoors. NEVER fill fuel tank when engine is running or hot. DO NOT light a cigarette or smoke when filling the fuel tank.

CAUTION: Do not overfill the fuel tank. Always allow room (about 1/2") for fuel expansion.

IMPORTANT: It is important to prevent gum deposits from forming in essential fuel system parts such as the carburetor, fuel filter, fuel hose or tank during storage. Also, experience indicates that alcohol-blended fuels (called gasohol, ethanol or methanol) can attract moisture which leads to separation and formation of acids during storage. Acidic gas can damage the fuel system of an engine while in storage.

To avoid engine problems, the fuel system should be emptied before storage of 30 days or longer. Drain the gas tank, start the engine and let it run until the fuel lines and carburetor are empty. Use fresh fuel next season. See "Storage" Instructions on page 13 for additional information.

Never use engine or carburetor cleaner products in the fuel tank or permanent damage may occur.

To add fuel:

- Clean area around fuel fill cap, remove cap.
- Add "**UNLEADED**" regular gasoline, slowly, to fuel tank. Leave about a 1/2" space in the fuel tank for fuel expansion. **Do not overfill fuel tank.**
- Install fuel cap and wipe up any spilled gasoline.



OPERATING THE GENERATOR

CAUTION! Never start, or stop, the generator with electrical loads connected to the receptacles.

Starting the Engine

- Disconnect **all** electrical loads from the generator.
- Make sure the idle control is turned **OFF**.
- Open the fuel shut-off valve.
- Set the Ignition Switch to the **On (-)** position.
- Pull choke control out to close choke. **Note:** If engine is warm, you may not need as much choking.

Note: Make sure the idle control switch is “Off” before starting the engine.

For Electric Start:

- Press electric starter switch until engine cranks and starts.

For Manual Start:

- Pull slowly on recoil handle until you feel some resistance. Then pull rapidly to start engine. Return recoil slowly, do not let it “snap back.”

Applying Electrical Loads

- Let engine stabilize and warm up for about five minutes after starting.
- Plug in and turn on the desired 120 or 240 volt, single phase, 60 Hertz, AC electrical loads. **DO NOT OVERLOAD THE GENERATOR.** Add up the rated watts (or amps) of all loads to be connected at one time. This total should not be greater than the rated wattage/amperage capacity of the generator. See page 10 “Don’t Overload the Generator for details

Stopping the Engine

- Disconnect **all** electrical loads
- Turn **OFF** idle control.
- Run engine at no-load for a few minutes.
- Set the Ignition Switch to the **Stop (o)** position
- Close the fuel shut-off valve.

Operating Automatic Idle Control

This switch is designed to greatly improve fuel economy. When this switch is turned **ON**, the engine will only run at its normal high governed engine speed when an electrical load is connected. When an electrical load is removed, the engine will run at a reduced speed. With the switch **OFF**, the engine will run at the normal high engine speed. **Always have the switch OFF when starting and stopping the engine.**

Charging a Battery

DANGER! Storage batteries give off explosive hydrogen gas while recharging. An explosive mixture will remain around the battery for a long time after it has been charged. The slightest spark can ignite the hydrogen and cause an explosion. Such an explosion can shatter the battery and cause blindness or other serious injury.

DANGER! Do not permit smoking, open flame, sparks or any other source of heat around a battery. Wear protective goggles, rubber apron and rubber gloves when working around a battery. Battery electrolyte fluid is an extremely caustic sulfuric acid solution that can cause severe burns. If spill occurs flush area with clear water immediately.

Your generator has the capability of recharging a discharged 12-volt automotive or utility style storage battery. **Do not** use the unit to charge any 6-volt batteries. **Do not** use the unit to crank an engine having a discharged battery.

To recharge 12-volt batteries, proceed as follows:

- Check fluid level in all battery cells. If necessary, add **ONLY** distilled water to cover separators in battery cells. **Do not use tap water.**
- If the battery is equipped with vent caps, make sure they are installed and are tight.
- If necessary, clean battery terminals.



- Connect battery charge cable connector plug to panel receptacle identified by the words "12-VOLT D.C."
- Connect battery charge cable clamp with **red** handle to the **positive (+)** battery terminal
- Connect battery charge cable clamp with **black** handle to the **negative (-)** battery terminal.
- Start engine. Let the engine run while battery recharges.
- When battery has charged, shut down engine

NOTE: Use an automotive hydrometer to test battery state of charge and condition. Follow the hydrometer manufacturer's instructions carefully. Generally, a battery is considered to be at 100% state of charge when specific gravity of its fluid (as measured by hydrometer) is 1.260 or higher.

CORD SETS FOR RECEPTACLES

This generator is equipped with the following receptacles:

■ Two 120-Volt, 20 Amp Receptacles

These receptacles are protected against overload by a 20-amp push-to-reset circuit breaker. Use each receptacle to operate 120 volt, single phase 60 Hz, AC electrical loads requiring up to 2400 watts (2.4 kW) at 20 amps of current. Use cord sets that are rated 125 volts at 20 amps (or greater).

Figure 7 — 120 Volt, 20 Amp Receptacles

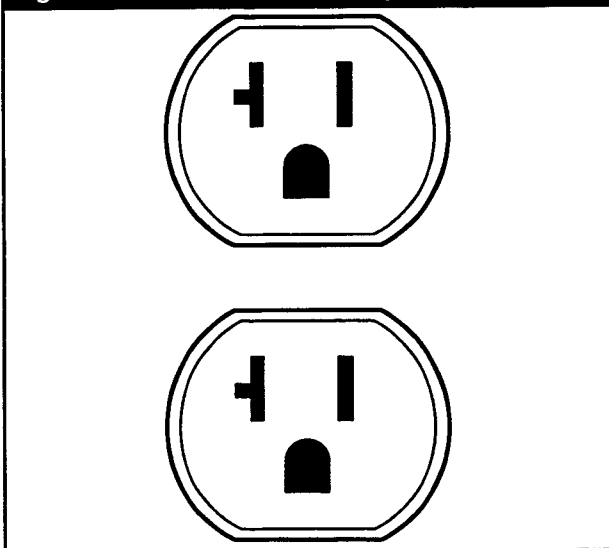

■ 120-Volt, 20 Amp Locking Type Receptacle

Use NEMA L5-20P type plug with this receptacle. Generac provides a plug as part of the optional accessories that go with the generator (Part # 37806). Connect a 3-wire cord set rated 125 volts at 20 AC amps to the plug (Figure 8). Use this receptacle to operate 120 volt AC, 60 Hz, single phase loads requiring up to 2400 watts (2.4 kW) of power at 20 AC amps. The outlet is protected by a 20 amp push-to-reset circuit breaker.

Figure 8 — 120 Volt, 20 Amp Receptacle

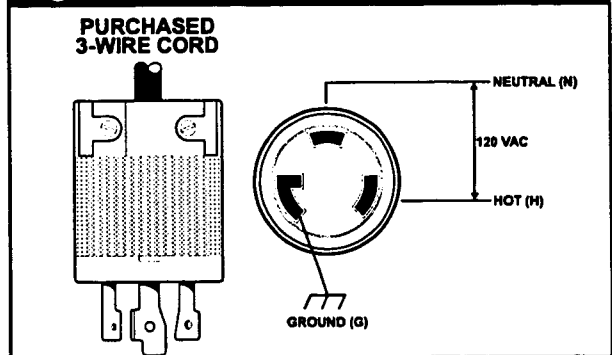

■ 120-Volt, 30 Amp Locking Type Receptacle

Use NEMA L5-30P type plug with this receptacle. Generac provides a plug as part of the optional accessories that go with the generator (Part # 37806). Connect a 3-wire cord set rated 125 volts at 30 AC amps to the plug (Figure 9). Use this receptacle to operate 120 volt AC, 60 Hz, single phase loads requiring up to 3600 watts (3.6 kW) of power at 30 AC amps. The outlet is protected by a 30 amp push-to-reset circuit breaker.

Figure 9 — 120 Volt, 30 Amp Receptacle

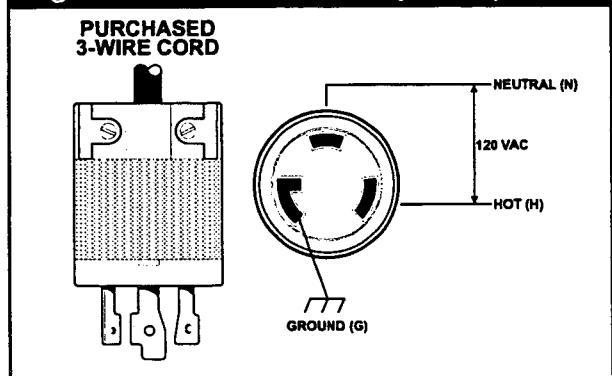



■ 120/240 Volt, 30 Amp Locking Type Receptacle

Use NEMA L14-30P type plug with this receptacle. You can order one from Generac (Part # 43438). Connect a 4-wire cord set rated 250 volt at 30 AC amps (or greater) (Figure 10). You can use the same 4-wire cord if the you plan only to run a 120 volt load. This receptacle powers 120/240 volt AC, 60 Hz, single phase loads requiring up to 3600 watts of power (3.6 kW) at 30 AC Amps for 120 volts; 7200 watts of power (7.2 kW) at 30 AC amps for 240 volts. The outlet is protected by a 30 amp push-to-reset circuit breaker.

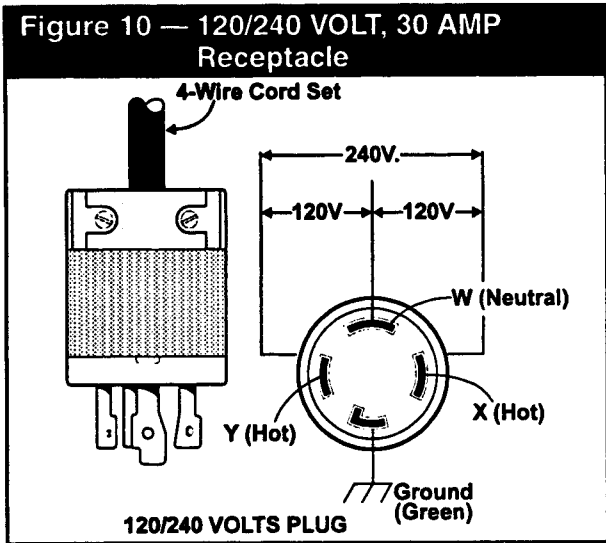

■ 240 Volt, 50 amp Receptacles

Use a compatible 3 prong plug with this receptacle (Figure 11). Connect a 3-wire cord set rated 250 volts at 50 AC amps to the plug. Use this receptacle to operate 240 volts AC, 50 Hz, single phase loads requiring up to 10000 watts (10 kW) of power.

⚠ CAUTION! Although this outlet states it has a 240 volts 50-amp rating (up to 12,500 watts), the generator is only rated for 10000 WATTS. Powering loads that exceed the wattage/ amperage capacity of the generator can damage it or cause serious injuries. Loads with 240 volts powered through this outlet should not exceed 41.7 amps of current.

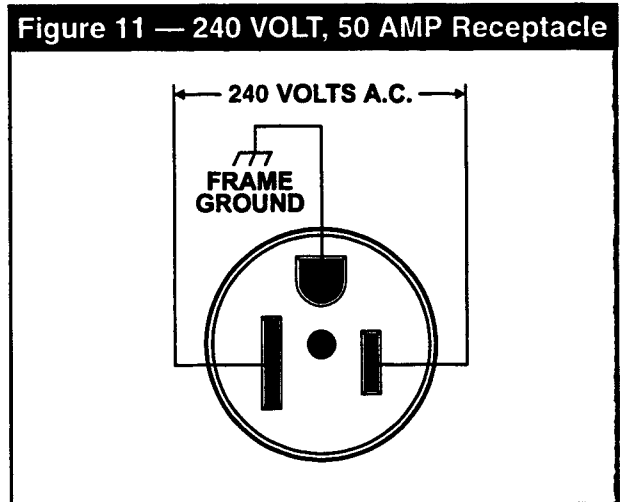



DON'T OVERLOAD THE GENERATOR

Overloading a generator in excess of its rated wattage capacity can result in damage to generator and to connected electrical devices. Observe the following, to prevent overloading the unit:

- Add up the total wattage of all electrical devices to be connected at one time. This total should **NOT** be greater than the generator's wattage capacity.
- The rated wattage of lights can be taken from light bulbs. The rated wattage of tools, appliances and motors can usually be found on a data plate or decal affixed to the device.
- If the appliance, tool or motor does not give wattage, multiply volts times ampere rating to determine watts (volts x amps = watts).
- Some electric motors, such as induction types, require about two-and-a-half times more watts of power for starting than for running. This surge of power lasts for only a few seconds when starting such motors. Be sure you allow for this high starting wattage when selecting electrical devices to connect to your generator. First figure the watts needed to start the largest motor. Add to that figure the running watts of all other connected loads.
- Items in the guide below are provided to help you to determine how many items the generator can operate at one time

ENGINE PROTECTIVE DEVICES

■ Low Oil Pressure Shutdown System

The engine is equipped with a low oil pressure sensor that shuts down the engine automatically when the oil pressure drops below 6 psi. If the engine shuts down by itself and the fuel tank has enough gasoline, check engine oil level.

1. Initial Start-up: A delay built in the shutdown system allows oil pressure to build during starting. The delay allows the engine to run for about 10 seconds before sensing oil pressure.

2. Sensing Low Pressure: If the system senses low oil pressure during operation, the engine shuts down.

3. Restarting: If you try to restart the engine within 5 to 10 seconds after it shuts down, the engine may NOT start. The system needs 5 to 10 seconds to reset.

IMPORTANT: If you do restart the engine after such a shutdown and not corrected the low oil pressure, the engine runs for about 10 seconds as described above and then stops.

WATTAGE REFERENCE GUIDE

| | RUNNING WATTS | | RUNNING WATTS |
|-------------------------------|---------------|--------------------------------------|---------------|
| *Air Conditioner (12,000 Btu) | 1700 | Impact Wrench | 500 |
| Battery Charger (20 amp) | 500 | *Jet Pump | 800 |
| Belt Sander (3") | 1000 | Lawn Mower | 1200 |
| Chain Saw | 1200 | Light Bulb | 100 |
| Circular Saw (6-12") | 800 to 1000 | Microwave Oven | 700 |
| Coffee Maker | 1000 | *Milk Cooler | 1100 |
| *Compressor (1 HP) | 2000 | Oil Burner on Furnace | 300 |
| *Compressor (3/4 HP) | 1800 | Oil Fired Space Heater (140,000 Btu) | 400 |
| *Compressor (1/2 HP) | 1400 | Oil Fired Space Heater (85,000 Btu) | 225 |
| *Freezer | 500 | Oil Fired Space Heater (30,000 Btu) | 150 |
| Disc Sander (9") | 1200 | *Paint Sprayer, Airless (1/3 HP) | 600 |
| Edge Trimmer | 500 | Paint Sprayer, Airless (handheld) | 150 |
| Electric Nail Gun | 1200 | Radio | 50 to 200 |
| Electric Range (one element) | 1500 | *Refrigerator | 600 |
| Electric Skillet | 1250 | Slow Cooker | 200 |
| *Furnace Fan (1/3 HP) | 1200 | *Submersible Pump (1-1/2 HP) | 2800 |
| Hair Dryer | 1200 | *Submersible Pump (1 HP) | 2000 |
| Hand Drill (1") | 1100 | *Submersible Pump (1/2 HP) | 1500 |
| Hand Drill (1/2") | 750 to 1000 | Sump Pump | 600 |
| Hand Drill (3/8") | 500 | *Table Saw (10") | 1750 to 2000 |
| Hand Drill (1/4") | 250 | Television | 200 to 500 |
| Hedge Trimmer | 450 | | |

* Allow 2-1/2 times the listed watts for starting these devices.



GENERAC
The Reliable One

GENERAL MAINTENANCE RECOMMENDATIONS

The Owner/Operator is responsible for making sure that all periodic maintenance tasks are completed on a timely basis; that all discrepancies are corrected; and that the unit is kept clean and properly stored. **Never operate a damaged or defective generator.**

ENGINE MAINTENANCE

■ Check Engine Oil Level

Check engine crankcase oil level frequently (prior to each use or at least every eight hours of operation). See Page 5 for recommended oils. Rest unit on a level surface and remove dipstick from extended oil fill tube. Wipe dipstick dry and reinstall all the way into the oil fill tube. Again remove dipstick. Oil should be at dipstick FULL mark. Add oil as necessary. **DO NOT OVERFILL ABOVE "FULL" MARK.**

■ Changing Oil and Oil Filter

Change oil after the first eight hours of operation. Thereafter, change oil every 50 operating hours under normal conditions. If engine is operated under heavy load or in high ambient temperatures, change oil every 25 hours of operation. Drain oil from oil drain plug while engine is still warm from running.

Change engine oil filter every 100 hours of operation (every second oil change). Before installing new filter, lightly lubricate filter gasket with fresh, clean engine oil. Screw new filter on by hand until gasket contacts the filter adapter. Then tighten about 3/4 turn further. Start and run engine for about 30 seconds, then shut down. Recheck oil level and add oil as necessary. Finally, start engine and check for leaks. See figure 12 below for location of oil filter and oil drain plug.

Figure 12 — Oil Drain Plug and Oil Filter

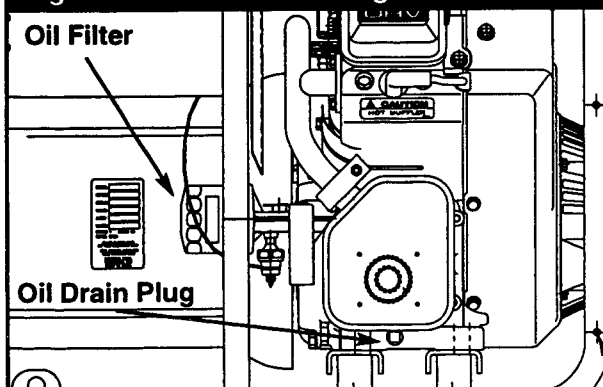

■ Replace Spark Plugs

Remove and replace spark plugs (Champion RC12YC) every 100 operating hours or once annually, whichever comes first. See ENGINE SPECIFICATIONS for recommended spark plugs. Set gap on plugs to 0.76mm.

CAUTION! DO NOT blast clean spark plugs. Clean with pen knife or wire brush and solvent.

■ Service Engine Air Cleaner

Your engine will not run properly and may be damaged if you run it using a dirty air cleaner. Clean or replace foam pre-cleaner every 25 hours of operation. Service cartridge every 100 operating hours or once annually, whichever comes first. Clean or replace more often if operating under dusty or dirty conditions.

To service foam pre-cleaner (Figure 13), proceed as follows:

Figure 13 — Replacing Air Cleaner Components

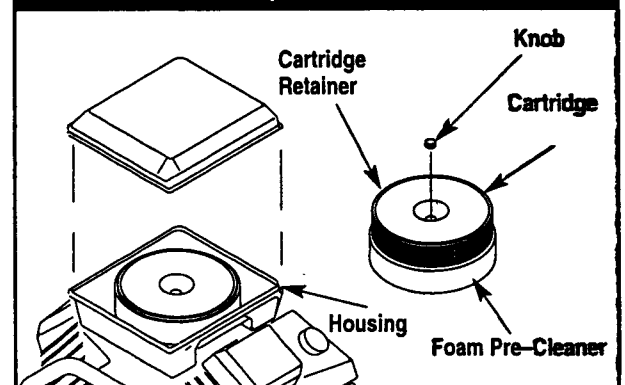

- The cover is attached to the air cleaner housing by two latches. Lift up on the latches to unlock them, then remove the cover.
- Carefully remove foam pre-cleaner from around the cartridge.
- Replace pre-cleaner or wash in liquid detergent and water.
- Squeeze (don't twist) pre-cleaner in a clean, dry cloth.
- Saturate pre-cleaner in engine oil. Squeeze in a clean absorbent cloth to remove excess oil.

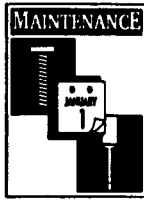

NOTE: If you are going to clean the PAPER CARTRIDGE do not install the foam pre-cleaner. Proceed to the instructions for servicing the cartridge.

- Carefully install the foam pre-cleaner around the cartridge.

To service the paper cartridge, proceed as follows:

- Clean cartridge by tapping gently on a flat surface. If cartridge is very dirty, replace or wash in a low or non-sudsing detergent and warm water solution.
- Rinse thoroughly with flowing water from mesh side until water runs clear.
- Let cartridge dry thoroughly before using.

CAUTION! DO NOT use petroleum solvents such as kerosene to clean the element. Such solvents will cause deterioration of the element. DO NOT oil the element. DO NOT use pressure air to clean or dry the element.

- Reinstall paper cartridge, retain with cartridge retainer and knob.
- Carefully install foam pre-cleaner.
- Install cover assembly and latch onto air cleaner body.

■ Engine Governed Speed

Engine speed was properly adjusted at factory and should require no additional adjustment. **DO NOT** attempt to change engine speed.

Excessively high speeds are dangerous and increase risk of personal injury. Excessively low speeds impose a heavy load on the engine when sufficient power is not available, which may shorten engine life.

Operating the engine at incorrect speed settings affects electrical generator operation as follows:

- Operating engine at high speeds results in an over-frequency and over-voltage condition.
- Operating engine at low speeds causes an under-frequency and under-voltage condition.

IMPORTANT: Incorrect frequency and/or voltage may damage some connected electrical loads.

If you suspect engine speed is incorrect, take your generator to an authorized service facility for repair and adjustment.

■ Clean Spark Arrestor Muffler

The engine exhaust muffler has a spark arrester screen. The screen should be inspected every 100 operating hours, or once each year, whichever comes first.

DANGER! Let muffler cool before working on it. Contact with a hot muffler or engine can cause severe burns.

NOTE: If you use your generator on any forested, brush or grass-covered unimproved land, it must have a spark arrester. The spark arrester must be cleaned and maintained in good condition by the owner or operator.

The preceding is required by law in the State of California. Other states may have similar laws. Federal laws apply on federal lands.

Clean and inspect the spark arrester as follows:

- Remove four screws that attach the spark arrester screen.
- Inspect the screen and replace if torn, perforated or otherwise damaged. **DO NOT USE** a defective screen. If the screen is not damaged, clean it with a commercial solvent.
- Reattach the screen and the heat shield.

Figure 14 — Location of Ground Lug

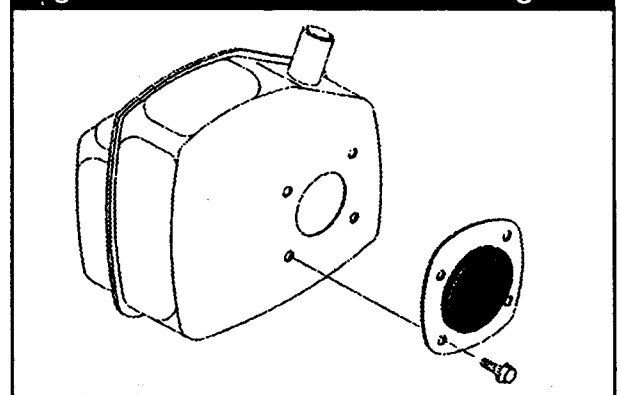

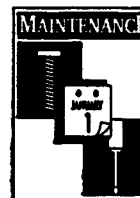

GENERATOR MAINTENANCE

Generator maintenance consists of keeping the unit clean and dry. Operate and store the unit in a clean dry environment where it will not be exposed to excessive dust, dirt, moisture or any corrosive vapors. Make sure the cooling air slots in the generator do not become clogged with snow, leaves or other foreign material.

Check cleanliness of the generator frequently and clean when dust, dirt, oil, moisture or other foreign substances are visible on its exterior surface.

NOTE: We **DO NOT** recommend using a garden hose to clean generator. Water can enter the engine fuel system and cause problems. In addition, if water enters the generator through the cooling air slots, some water will be retained in the voids and cracks of the rotor and stator winding insulation. Water and dirt buildup on the generator internal windings will eventually decrease the insulation resistance of these windings.

■ To Clean the Generator

- Use a damp cloth to wipe exterior surfaces clean.
- Soft, bristle brush may be used to loosen caked on dirt or oil.
- A vacuum cleaner may be used to pick up loose dirt and debris.
- Low pressure air (not to exceed 25 psi) may be used to blow away dirt. Inspect cooling air slots and opening on generator. These openings must be kept clean and unobstructed.

STORAGE INSTRUCTIONS

The generator should be started at least once every seven days and allowed to run at least 30 minutes. If this cannot be done and you must store the unit for more than 30 days, use the following guidelines to prepare it for storage.

■ Generator Storage

- Clean the generator as outlined in "To Clean the Generator."
- Check that the cooling air slots and openings on the generator are open and unobstructed.
- Change engine oil.
- Drain fuel and run engine until the fuel system is empty.
- Remove spark plugs and pour about 1 ounce of clean engine oil into spark plug holes. Crank engine over slowly several times, to distribute oil. Install and tighten spark plugs.

- Store the unit in a clean dry place.



DANGER: Storage covers can be flammable. Do not place a storage cover over a hot generator. Let the unit cool for 5 minutes before placing cover on the unit.

■ Other Storage Tips

- Do not store gasoline from one season to another.
- Replace your gasoline can if it starts to rust. Rust and/or dirt in a gasoline can cause problems when you use that fuel with this unit.
- Store in clean and dry area.

SPECIFICATIONS

■ Generator

| | |
|---|---------------------|
| Rated Maximum Continuous | |
| AC Power Output | 10000 watts (10 kW) |
| Rated Voltage..... | 120/240 Volts |
| Rated Maximum Current at 240 Volts..... | 41.7 AC amperes |
| Rated Maximum Current at 120 Volts..... | 83.3 AC amperes |
| Phase..... | 1 |
| Rated AC Frequency | 60 Hertz |
| Number of Rotor Poles..... | 2 |
| Driven Speed of Rotor..... | 3600 rpm |
| Battery Size..... | Y50-N182-A3 |

■ Engine

| | |
|---------------------------------|---------------------|
| Type | Air-Cooled V-Twin |
| Displacement | 570cc |
| Valve Arrangement..... | Overhead Valves |
| Setting at no load | 3600 rpm |
| Lubrication System..... | Pressurized |
| Oil Capacity | |
| With Oil Filter Change | 3.5 U.S. Pints |
| Without Oil Filter Change | 3 U.S. Pints |
| Recommended Spark Plugs | |
| Champion..... | RC12YC |
| Autolite | 3924 |
| Spark Plug Gap..... | 0.030 inch (0.76mm) |
| Spark Plug Torque | 200 inch-pounds |
| | (22.5 N-m) |
| Rated Horsepower | 19 at 3600 RPM |
| Fuel Capacity..... | 5 U.S. Gallons |
| | (19 Liters) |



TROUBLESHOOTING POINTS

| Problem | Cause | Correction |
|--|---|--|
| Engine is running, but no AC output is available. | <ol style="list-style-type: none"> 1. One of the circuit breakers is open. 2. Fault in generator. 3. Poor connection or defective cord set. 4. Connected device is bad. | <ol style="list-style-type: none"> 1. Reset circuit breaker. 2. Contact Generac Service Facility. 3. Check and repair. 4. Connect another device that is in good condition. |
| Engine runs good at no-load but "bogs down" when loads are connected | <ol style="list-style-type: none"> 1. Short circuit in a connected load. 2. Engine speed is too slow. 3. Generator is overloaded. 4. Shorted generator circuit. | <ol style="list-style-type: none"> 1. Disconnect shorted electrical load. 2. Contact Generac Service Facility. 3. See "Don't Overload the Generator". 4. Contact Generac Service Facility. |
| Engine will not start; or starts and runs rough. | <ol style="list-style-type: none"> 1. Run/Stop Switch set to STOP. 2. Dirty air cleaner 3. Out of gasoline. 4. Stale gasoline. 5. Spark plug wire not connected to spark plug. 6. Bad spark plug. 7. Water in gasoline. 8. Overchoking. 9. Excessively rich fuel mixture. 10. Intake valve stuck open or closed. 11. Engine compression lost. 12. Failed battery. | <ol style="list-style-type: none"> 1. Set switch to RUN. 2. Clean or replace air cleaner. 3. Fill fuel tank. 4. Drain gas tank; fill with fresh fuel. 5. Connect wire to spark plug. 6. Replace spark plug. 7. Drain gas tank; fill with fresh fuel. 8. Open choke fully and crank engine. 9. Contact Generac Service Facility. 10. Contact Generac Service Facility. 11. Contact Generac Service Facility. 12. Replace battery. |
| Engine shuts down during operation | <ol style="list-style-type: none"> 1. Out of gasoline. 2. Low oil level. | <ol style="list-style-type: none"> 1. Fill fuel tank. 2. Fill crankcase to proper level. |
| Engine lacks power. | <ol style="list-style-type: none"> 1. Load is too high. 2. Dirty air filter. | <ol style="list-style-type: none"> 1. See "Don't Overload the Generator" 2. Replace air filter. |
| Engine "hunts" or falters. | <ol style="list-style-type: none"> 1. Choke is opened too soon. 2. Carburetor is running too rich or too lean. | <ol style="list-style-type: none"> 1. Move choke to halfway position until engine runs smoothly. 2. Contact Generac Service Facility. |



NOTES

A series of horizontal lines for taking notes, starting below the "NOTES" header and extending to the bottom of the page.

WIRING DIAGRAM

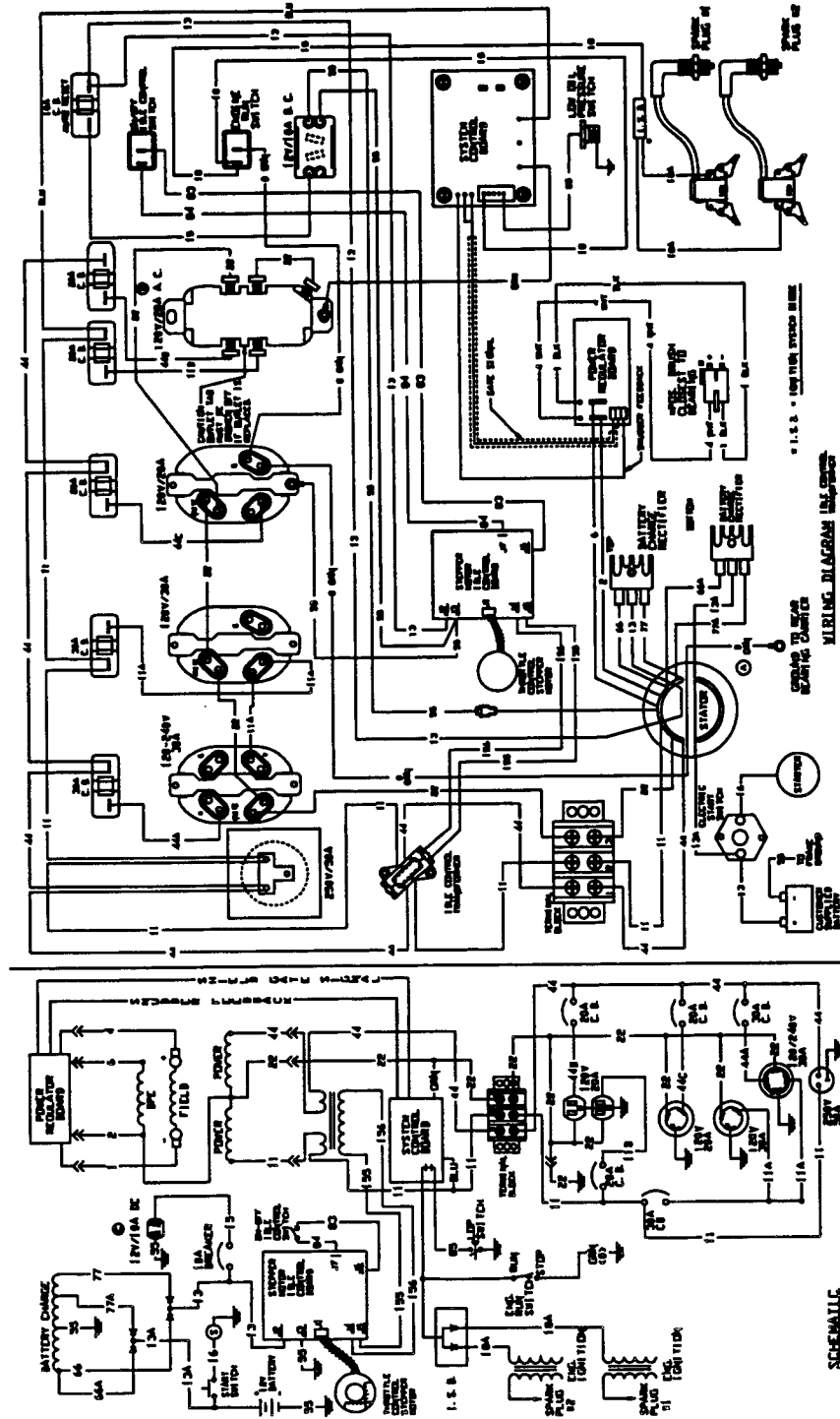

Drawing No. 95918

Extended Life Generator

CONTROL PANEL EXPLODED VIEW AND PARTS LIST

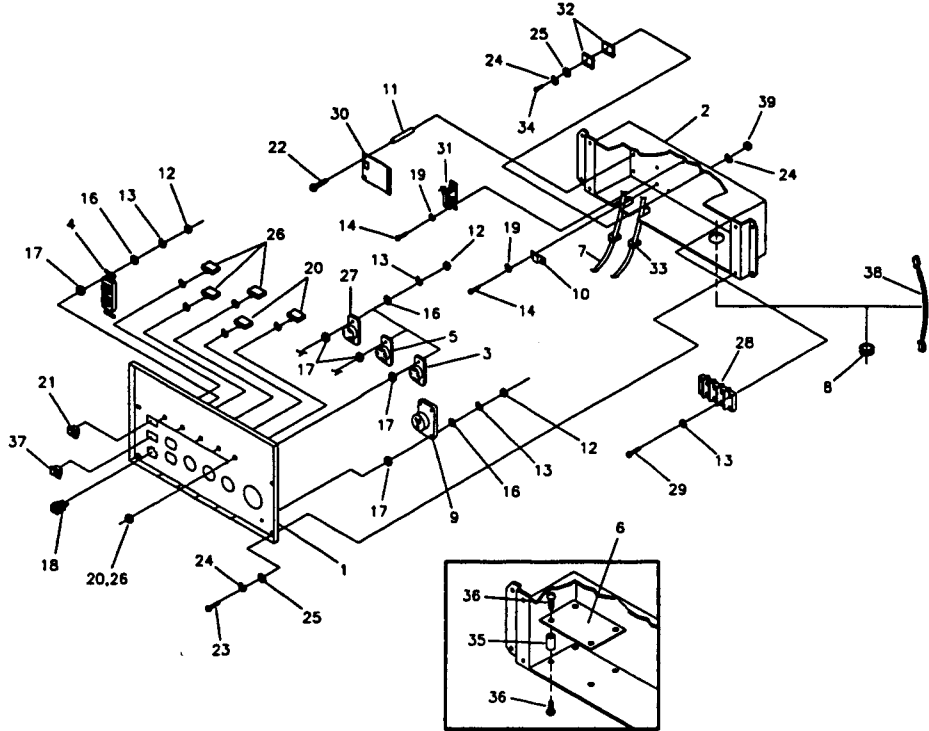

| Item | Part # | Qty. | Description | Item | Part # | Qty. | Description |
|------|--------|------|--|------|---------|------|-----------------------------|
| 1 | A95909 | 1 | PANEL, Control | 20 | 75207-A | 2 | CIRCUIT BREAKER, 30 Amp |
| 2 | B95906 | 1 | BOX, Control | 21 | 78653 | 1 | SWITCH, Run - Stop |
| 3 | 43437 | 1 | OUTLET, 120/240V, 30 Amp Locking Type | 22 | 93986 | 4 | SCREW, M3 - 0.5 x 20mm |
| 4 | 68759 | 1 | OUTLET, 120V, 20 Amp Duplex GFCI | 23 | 91526 | 4 | SCREW, M5 - .08 x 12mm |
| 5 | 68868 | 1 | OUTLET, 120V, 30 Amp Locking Type | 24 | 49226 | 5 | LOCK WASHER, M5 |
| 6 | 96476 | 1 | BOARD, System Control | 25 | 23897 | 5 | FLAT WASHER, M5 |
| 7 | 96067 | 1 | ASSEMBLY, Engine Harness | 26 | 75207 | 3 | CIRCUIT BREAKER, 20 Amp |
| 8 | 90576 | 1 | GROMMET, Rubber | 27 | 74190 | 1 | OUTLET, 120V/20A Locking |
| 9 | 74191 | 1 | OUTLET, 50 Amp 240V | 28 | 92953 | 1 | BLOCK, 50 Amp, 3 - Terminal |
| 10 | 87962 | 1 | CIRCUIT BREAKER | 29 | 80077 | 4 | SCREW, M4 x 20mm |
| 11 | 93929 | 4 | STAND OFF, 1/2" Hex | 30 | 94117 | 1 | BOARD, Idle Control |
| 12 | 51715 | 12 | NUT, M4 - 0.7 Hex | 31 | 84028 | 1 | TRANSFORMER, Idle Control |
| 13 | 22264 | 16 | LOCK WASHER, #8 M4 | 32 | 65795 | 2 | RECTIFIER, Battery Charge |
| 14 | 43181 | 4 | SCREW, M3 - .05 x 10mm | 33 | 84135 | 1 | GROMMET, Rubber |
| 16 | 38150 | 12 | FLAT WASHER, #8 | 34 | 79224 | 1 | SCREW, M5 - 0.8 x 30mm |
| 17 | 23365 | 12 | WASHER, #8 Shakeproof | 35 | 64525 | 4 | STAND OFF, 3/4" Hex |
| 18 | 90418 | 1 | OUTLET, 12V DC Snap | 36 | 64526 | 8 | SCREW, #6-32 x 3/8" Tap |
| 19 | 43182 | 4 | LOCK WASHER, M3 | 37 | 82538 | 1 | SWITCH, On - Off |
| | | | | 38 | 96471 | 1 | ASSEMBLY, Extension Cord |
| | | | | 39 | 51716 | 1 | HEXNUT, M5 - 0.8 |

Drawing No. 96025

GENERATOR EXPLODED VIEW

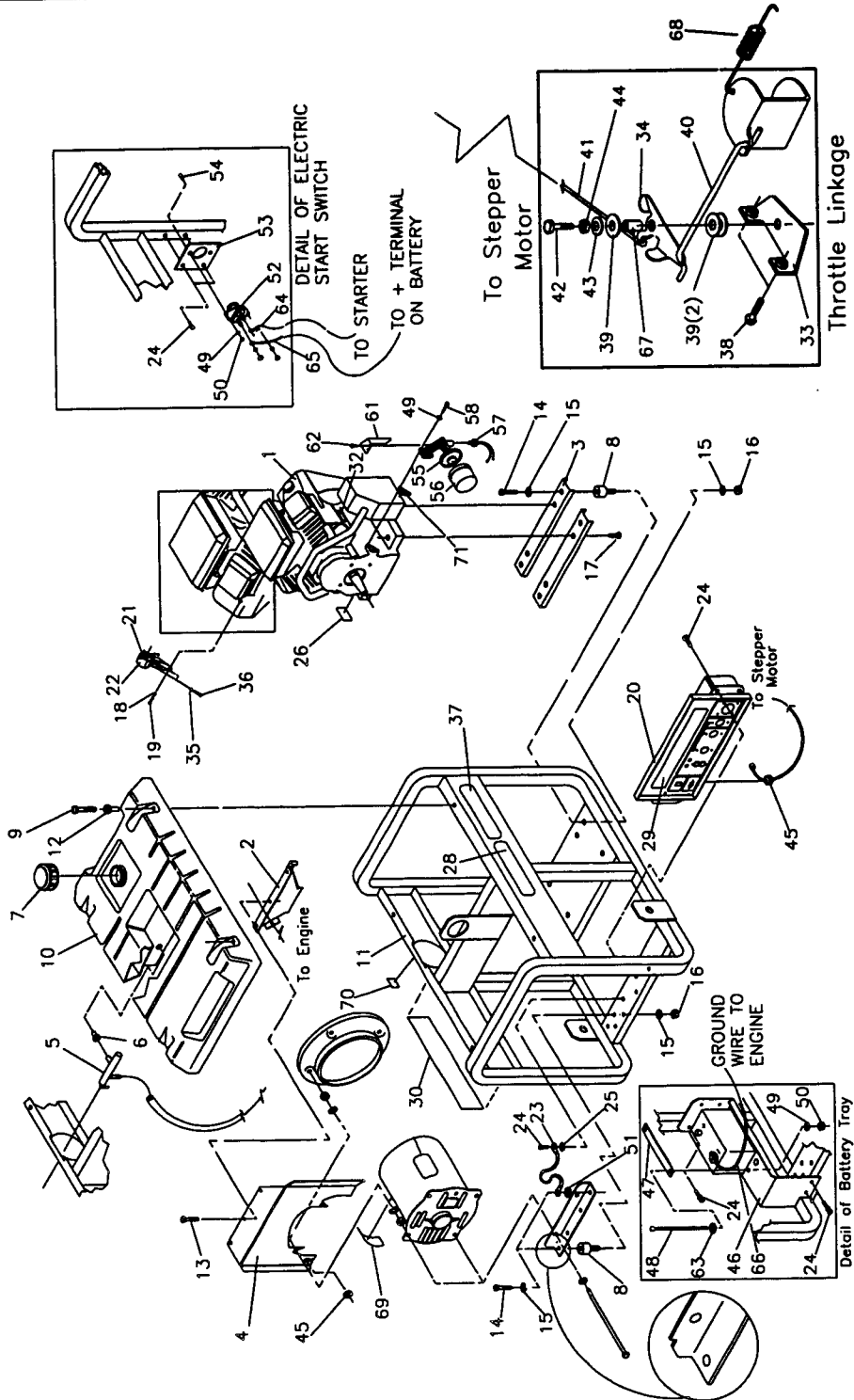

Drawing No. 96024

GENERATOR PARTS LIST

| Item | Part # | Qty. | Description | Item | Part # | Qty. | Description |
|-------------|---------------|-------------|-----------------------------------|-------------|---------------|-------------|--------------------------------------|
| 1 | NSP | 1 | ENGINE, V-Twin Spec93571 | 39 | 96716 | 3 | WASHER, Nylon |
| 2 | B93074 | 1 | SHIELD, Heat | 40 | 95920 | 1 | LINKAGE, Stepper Motor to Bell Crank |
| 3 | A77304 | 2 | SUPPORT, Engine | 41 | 95921 | 1 | LINKAGE, Bell Crank to Throttle |
| 4 | B90916 | 1 | STATOR, Heat Shield | 42 | 33141 | 1 | CAPSCREW, #10-32 x 3/4" Hex Hd. |
| 5 | 80270 | 1 | VALVE, Fuel Shut-Off | 43 | 51713 | 1 | WASHER, M5 Flat |
| 6 | 78299 | 1 | BUSHING, Fuel Valve | 44 | 49226 | 1 | WASHER, M5 Lock |
| 7 | 90878 | 1 | CAP, Fuel Tank | 45 | 62265 | 2 | GROMMET, Rubber |
| 8 | 35097 | 8 | MOUNTS, Vibration | 46 | A84650 | 1 | TRAY, Battery |
| 9 | 78831B | 4 | CAPSCREW, M6-1.0 x 60mm | 47 | A44951 | 1 | BAR, Battery Hold-Down |
| 10 | 93615 | 1 | TANK, Fuel | 48 | 45000 | 2 | SCREW, 1/4-20" NC x 7" Hx Hd. Mach. |
| 11 | A92558 | 1 | CRADLE | 49 | 22097 | 9 | WASHER, 1/4" Lock |
| 12 | 83465 | 4 | GROMMET, Fuel Tank Mounting | 50 | 22127 | 6 | NUT, 1/4"-20 Hex |
| 13 | 56892 | 3 | CRIMPTITE, 10-24 x 3/8" | 51 | 22261 | 1 | SHAKEPROOF, 3/8" Internal |
| 14 | 23152 | 8 | CAPSCREW, 3/8-16 x 3/4" Lg. | 52 | 77282 | 1 | SWITCH, Starter |
| 15 | 22237 | 16 | WASHER, 3/8" Lock | 53 | 78289 | 1 | BRACKET, Starter Switch |
| 16 | 22241 | 8 | NUT, 3/8-16 Hex | 54 | 22287 | 2 | CAPSCREW, 1/4"-20 x 3/4" |
| 17 | 75246 | 4 | SELF-TAPPING, 3/8-16 x 1-1/4" Lg. | 55 | 90914 | 1 | ADAPTER, Oil Filter |
| 18 | 22129 | 2 | WASHER, M8-Lock | 56 | 70185 | 1 | FILTER, Oil |
| 19 | 39253 | 2 | CAPSCREW, M8-1.25 x 16 | 57 | 60108 | 1 | SWITCH, Low Oil Pressure |
| 20 | 96054 | 1 | ASSEMBLY, Control Panel | 58 | 40945 | 3 | CAPSCREW, M6-1.0 x 20 Socket Hd |
| 21 | 96867 | 1 | ASSEMBLY, Stepper Motor | 61 | A93841 | 1 | SHIELD, Oil Sensor Heat |
| 23 | 185-53621 | 1 | ASSEMBLY, Ground Wire | 62 | 46852 | 2 | TAPTITE, #10-32 x 1/4" |
| 24 | 86292 | 7 | CAPSCREW, #10 Self Driller | 63 | 22473 | 2 | WASHER, 1/4" Flat |
| 25 | 23762 | 1 | WASHER, #10 Shakeproof | 64 | 182-53621 | 1 | WIRE ASSEMBLY, Starter |
| 26 | 79661P | 1 | DECAL, Engine #93571 | 65 | 183-53621 | 1 | WIRE ASSEMBLY, Battery |
| 28 | 92982 | 1 | DECAL, Danger | 66 | 184-53621 | 1 | WIRE ASSEMBLY, Ground |
| 29 | 96056 | 1 | DECAL, Control Panel | 67 | 96378 | 1 | SPACER |
| 30 | 96055 | 1 | DECAL, Side Panel | 68 | 96717 | 1 | SPRING |
| 32 | 77816 | 1 | DECAL, Caution Hot Muffler | 70 | 73054 | 1 | DECAL, Fuel Shut Off |
| 33 | 95349 | 1 | PLATE, Adjust | 71 | 68548 | 1 | GASKET, Oil Filter Adapter |
| 34 | 95348 | 1 | BELL, Crank | | | | |
| 37 | 93826 | 1 | DECAL, Start Instruction | | | | |
| 38 | 75477 | 2 | SCRW, M5-0.8 x 20Lg. Phillips Hd. | | | | |

Drawing No. 96024

ROTOR AND STATOR EXPLODED VIEW

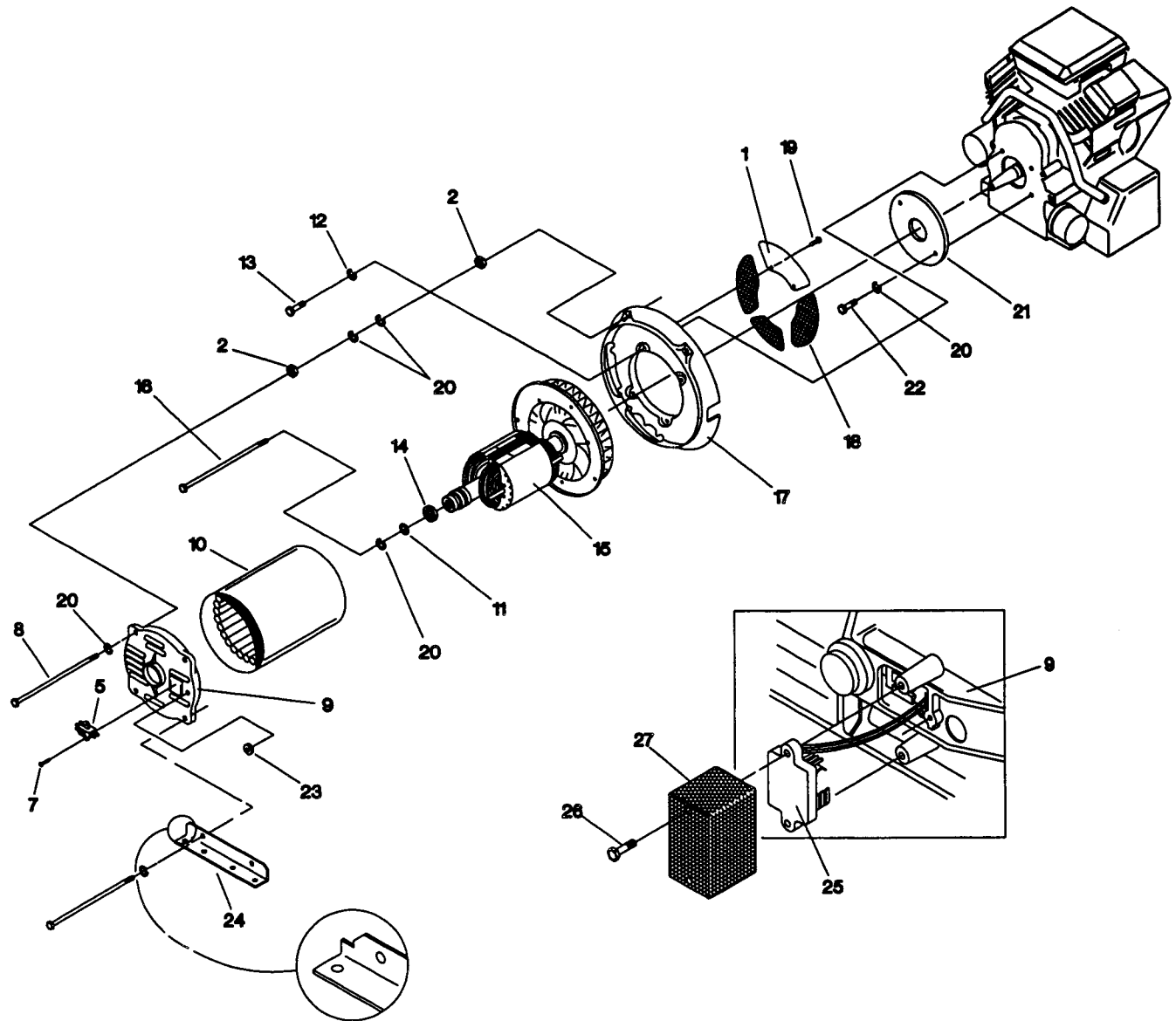

ROTOR AND STATOR PARTS LIST

| ITEM | PART NO. | QTY. | DESCRIPTION |
|-------------|-----------------|-------------|--------------------------------------|
| 1 | 71791 | 1 | PLATE, Cover |
| 2 | 24114 | 4 | NUT, 5/16-24" Hex |
| 5 | 66386 | 1 | ASSEMBLY, Brush |
| 7 | 66849 | 2 | SCREW, M5-0.8 x 16 Lg. Taptite |
| 8 | 77324 | 4 | CAPSCREW, 5/16"-24 x 12.25 Hex Head |
| 9 | A49410A | 1 | CARRIER, Rear Bearing |
| 10 | A94983 | 1 | ASSEMBLY, Stator 10-KW |
| 11 | 50190 | 1 | WASHER, 5/16" Flat |
| 12 | 22237 | 4 | WASHER, 3/8" Lock |
| 13 | 23152 | 4 | CAPSCREW, 3/8"-16 x 3/4" Hex Head |
| 14 | 65791 | 1 | BEARING |
| 15 | 92381 | 1 | ASSEMBLY, Rotor 10-KW |
| 16 | 53365 | 1 | CAPSCREW, 5/16"-24 x 10.75" Hex Head |
| 17 | A92774 | 1 | CASTING, Adapter |
| 18 | 55275 | 3 | GUARD, Fan |
| 19 | 46852 | 8 | SCREW, No. 10-32 x 1/4" |
| 20 | 22129 | 11 | WASHER, 5/16" Lock |
| 21 | A55277 | 1 | GUARD, Center |
| 22 | 86307 | 2 | CAPSCREW, 5/16"-24 x 3/4" Hex Head |
| 23 | 38057 | 1 | GROMMET, Rubber |
| 24 | A77303 | 1 | SUPPORT, Alternator |
| 25 | 92769 | 1 | ASSEMBLY, Power Regulator |
| 26 | 66849A | 2 | SCREW, M5-0.8 x 20 Lg. Taptite |
| 27 | A96423 | 1 | SCREEN, Finger Guard |



CALIFORNIA EMISSION CONTROL WARRANTY STATEMENT YOUR WARRANTY RIGHTS AND OBLIGATIONS

The California Air Resources Board ("CARB") and Generac Corporation are pleased to explain the Emission Control System Warranty on your new utility or lawn and garden equipment engine. In California, new utility and lawn and garden equipment engines must be designed, built and equipped to meet the State's stringent anti-smog standards. Generac Corporation will warrant the emission control system on your utility or lawn and garden equipment for the periods of time listed below provided there has been no abuse, neglect, unapproved modification, or improper maintenance of your utility or lawn and garden equipment engine.

Your emission control system may include parts such as the carburetor, ignition system and exhaust system. Also included may be the compression release system and other emission-related assemblies.

Where a warrantable condition exists, Generac Corporation will repair your utility or lawn and garden equipment engine at no cost to you for diagnosis, parts and labor.

MANUFACTURER'S EMISSION CONTROL SYSTEM WARRANTY COVERAGE:

Emissions control systems on 1995 and later model year utility and lawn and garden equipment engines are warranted for two years as hereinafter noted. If, during such warranty period, any emission-related part on your engine is defective in materials or workmanship, the part will be repaired or replaced by Generac Corporation.

OWNER'S WARRANTY RESPONSIBILITIES:

As the utility or lawn and garden equipment engine owner, you are responsible for the performance of the required maintenance listed in your owners manual. Generac Corporation recommends that you retain all receipts covering maintenance on your utility or lawn and garden equipment engine, but Generac Corporation will not deny warranty solely due to the lack of receipts or for your failure to provide written evidence of the performance of all scheduled maintenance.

As the utility or lawn and garden equipment engine owner, you should, however, be aware that Generac Corporation may deny you warranty coverage if your utility or lawn and garden equipment engine or a part thereof has failed due to abuse, neglect, improper maintenance or unapproved modifications.

You are responsible for presenting your utility or lawn and garden equipment engine to a Generac Corporation Authorized Service Outlet as soon as a problem exists. The warranty repairs should be completed in a reasonable amount of time, not to exceed 30 days.

Warranty service can be arranged by contacting either a Generac Corporation Authorized Service Outlet or by contacting Generac Corporation at:

**GENERAC CORPORATION PH: (920) 674-3750
P.O. BOX 239 FAX: (920) 674-5663
JEFFERSON, WI 53549**

IMPORTANT NOTE: This warranty statement explains your rights and obligations under the Emission Control System Warranty ("ECS Warranty") which is provided to you by Generac Corporation pursuant to California law. See also the Generac Corporation Limited Warranties for Generac Corporation which is enclosed herewith on a separate sheet and also is provided to you by Generac Corporation. The ECS Warranty applies only to the emission control system of your new engine. To the extent that there is any conflict in terms between the ECS Warranty and the Generac Corporation Warranty, the ECS Warranty shall apply except in any circumstances in which the Generac Corporation Warranty may provide a longer warranty period. Both the ECS Warranty and the Generac Corporation Warranty describe important rights and obligations with respect to your new engine.

Warranty service can only be performed by a Generac Corporation Authorized Service Outlet. At the time of requesting warranty service, evidence must be presented of the date of the sale to the original purchaser. The purchaser shall pay any charges for making service calls and/or for transporting the products to and from the place where the inspection and/or warranty work is performed. The purchaser shall be responsible for any damage or loss incurred in connection with the transportation of any engine or any part(s) thereof submitted for inspection and/or warranty work.

IF YOU HAVE ANY QUESTIONS REGARDING YOUR WARRANTY RIGHTS AND RESPONSIBILITIES, YOU SHOULD CONTACT GENERAC CORPORATION AT 1-800-526-2871

EMISSION CONTROL SYSTEM WARRANTY

Emission Control System Warranty ("ECS Warranty") for 1995 and Later Model Year Utility and Lawn and Garden Equipment Engines:

- A. **Applicability:** This warranty shall apply to 1995 and later model year utility and lawn and garden equipment engines. The ECS Warranty Period ("ECS Warranty Period") shall begin on the date the new engine or equipment is delivered to its original, end-use purchaser and shall continue for 24 consecutive months thereafter.
- B. **General Emissions Warranty Coverage:** Generac Corporation warrants to the original, end-use purchaser of the new engine or equipment and to each subsequent purchaser that each of its utility and lawn and garden equipment engines is:
1. Designed, built and equipped so as to conform with all applicable regulations adopted by the Air Resources Board pursuant to its authority, and
 2. Free from defects in materials and workmanship which, at any time during the ECS Warranty Period, will cause a warranted emissions - related part to fail to be identical in all material respects to the part as described in the engine manufacturer's application for certification.
- C. The ECS Warranty only pertains to emissions-related parts on your engine, as follows:
1. Any warranted, emissions-related parts which are not scheduled for replacement as required maintenance in the Owner's Manual shall be warranted for the ECS Warranty Period. If any such part fails during the ECS Warranty Period, it shall be repaired or replaced by Generac Corporation according to Subsection (4) below. Any such part repaired or replaced under the ECS Warranty shall be warranted for any remainder of the ECS Warranty Period.
 2. Any warranted, emissions-related part which is scheduled only for regular inspection as specified in the Owner's Manual shall be warranted for the ECS Warranty Period. A statement in such written instructions to the effect of "repair or replace as necessary" shall not reduce the ECS Warranty Period. Any such part repaired or replaced under the ECS Warranty shall be warranted for any remainder of the ECS Warranty Period.
 3. Any warranted, emissions-related part which is scheduled for replacement as required maintenance in the Owner's Manual shall be warranted for the period of time prior to first scheduled replacement point for that part. If the part fails prior to the first scheduled replacement, the part shall be repaired or replaced by Generac Corporation according to Subsection (4) below. Any such emissions-related part repaired or replaced under the ECS Warranty shall be warranted for the remainder of the ECS Warranty Period prior to the first scheduled replacement point for such emissions-related part.
 4. Repair or Replacement of any warranted, emissions-related part under this ECS Warranty shall be performed at no charge to the owner at a Generac Corporation Authorized Service Outlet.
 5. The owner shall not be charged for diagnostic labor which leads to the determination that a part covered by the ECS Warranty is in fact defective, provided that such diagnostic work is performed at a Generac Corporation Authorized Service Outlet.
 6. Generac Corporation shall be liable for damages to other original engine components or approved modifications proximately caused by a failure under warranty of any emission-related part covered by the ECS Warranty.
 7. Throughout the ECS Warranty Period, Generac shall maintain a supply of warranted emission-related parts sufficient to meet the expected demand for such emission-related parts.
 8. Any Generac Corporation authorized and approved emission-related replacement part may be used in the performance of any ECS warranty maintenance or repairs and will be provided without charge to the owner. Such use shall not reduce Generac Corporation ECS warranty obligations.
 9. Unapproved add-on modified parts may not be used to modify or repair a Generac Corporation engine. Such use voids this ECS Warranty and shall be sufficient grounds for disallowing an ECS Warranty claim. Generac Corporation shall not be liable hereunder for failures of any warranted parts of a Generac Corporation engine caused by the use of such an unapproved add-on or modified part.

EMISSION RELATED PARTS INCLUDE THE FOLLOWING:

1. Carburetor assembly and it's internal components.
 - a. Fuel filter
 - b. Carburetor gaskets
 - c. Intake pipe
2. Air cleaner assembly
 - a. Air filter element
3. Ignition system including:
 - a. Spark plug
 - b. Ignition module
4. Catalytic muffler (if so equipped)
 - a. Muffler gasket (if so equipped)
 - b. Exhaust manifold (if so equipped)
5. Crankcase breather assembly and its components.
 - a. Breather connection tube



Two-Year Limited Warranty For "GN" Engine Driven Portable Generators

GENERAC, LLC warrants to the original purchaser that the alternator and its related components for its portable generator will be free from defects in materials or workmanship for the items and period set forth below from the date of original purchase. This warranty is not transferable and applies only to portable generators driven by a GN-Series warranted engine.

| | Consumer* | Commercial* |
|------------|---|--------------------|
| Alternator | 2 years (2nd year parts only) | 1 year |
| Engine | Warranted solely by the engine manufacturer | |

With the exception of European Community Countries, all units bound for export shall be warranted for One (1) Year in Consumer applications, and 90 days in Commercial applications as defined below.

***NOTE: For the purpose of this warranty "consumer use" means personal residential household use by original purchaser. This does not apply to units used for Prime Power in place of utility. "Commercial Use" means all other uses, including rental, construction, commercial and income producing purposes. Once a generator has experienced commercial use, it shall thereafter be considered a commercial use generator for the purposes of this warranty.**

During said warranty period, GENERAC, LLC will, at its option, repair or replace any part which, upon examination by GENERAC, LLC, is found to be defective under normal use and service**. Starting batteries are not warranted by GENERAC, LLC. All transportation costs under warranty, including return to the factory if necessary, are to be borne by the purchaser and prepaid by him. This warranty does not cover normal maintenance and service and does not apply to a generator set, alternator, or parts which have been subjected to improper or unauthorized installation or alteration, misuse, negligence, accident, overloading, overspeeding, improper maintenance, repair or storage so as, in GENERAC, LLC'S judgement, to adversely affect its performance and reliability.

****NORMAL WEAR: As with all mechanical devices, the generator need periodic parts service and replacement to perform well. This warranty will not cover repair when normal use has exhausted the life of a part or generator.**

THERE IS NO OTHER EXPRESS WARRANTY. GENERAC, LLC HEREBY DISCLAIMS ANY AND ALL IMPLIED WARRANTIES, INCLUDING BUT NOT LIMITED TO THOSE OF MERCHANTABILITY AND FITNESS FOR A PARTICULAR PURPOSE TO THE EXTENT PERMITTED BY LAW. THE DURATION OF ANY IMPLIED WARRANTIES WHICH CANNOT BE DISCLAIMED IS LIMITED TO THE TIME PERIOD AS SPECIFIED IN THE EXPRESS WARRANTY. LIABILITY FOR CONSEQUENTIAL, INCIDENTAL OR SPECIAL DAMAGES UNDER ANY AND ALL WARRANTIES IS EXCLUDED. Some states do not allow limitations on how long an implied warranty lasts, or the exclusion or limitation of incidental or consequential damages, so the above limitations or exclusions may not apply to you. This warranty gives you specific legal rights and your may also have other rights, which vary from state to state.

For service, see your nearest GENERAC, LLC authorized warranty service facility or call 1-800-333-1322. Warranty service can be performed only by a GENERAC, LLC authorized service facility. This warranty will not apply to service at any other facility. At the time of requesting warranty service, evidence of original purchase date must be presented.

Generac Portable Products, LLC

Errata

For Manual No. 96023 (Generac Model #9801-1)

One word in the first paragraph on page 6 in the section "240 Volt, 50 amp Receptacles" is incorrect. Please replace that paragraph with the text shown below

240 Volt, 50 amp Receptacles

Use a compatible 3 prong plug with this receptacle (Figure 11). Connect a 3-wire cord set rated 250 volts at 50 AC amps to the plug. Use this receptacle to operate 240 volts AC, 60 Hz, single phase loads requiring up to 10,000 watts (10 kW) of power.

Errata

For Manual No. 96023 (Generac Model #9801-1)

The caption for Figure 14 on page 12 in your manual is incorrect. Please replace the old figure with that shown below. Generac regrets this inconvenience.

