

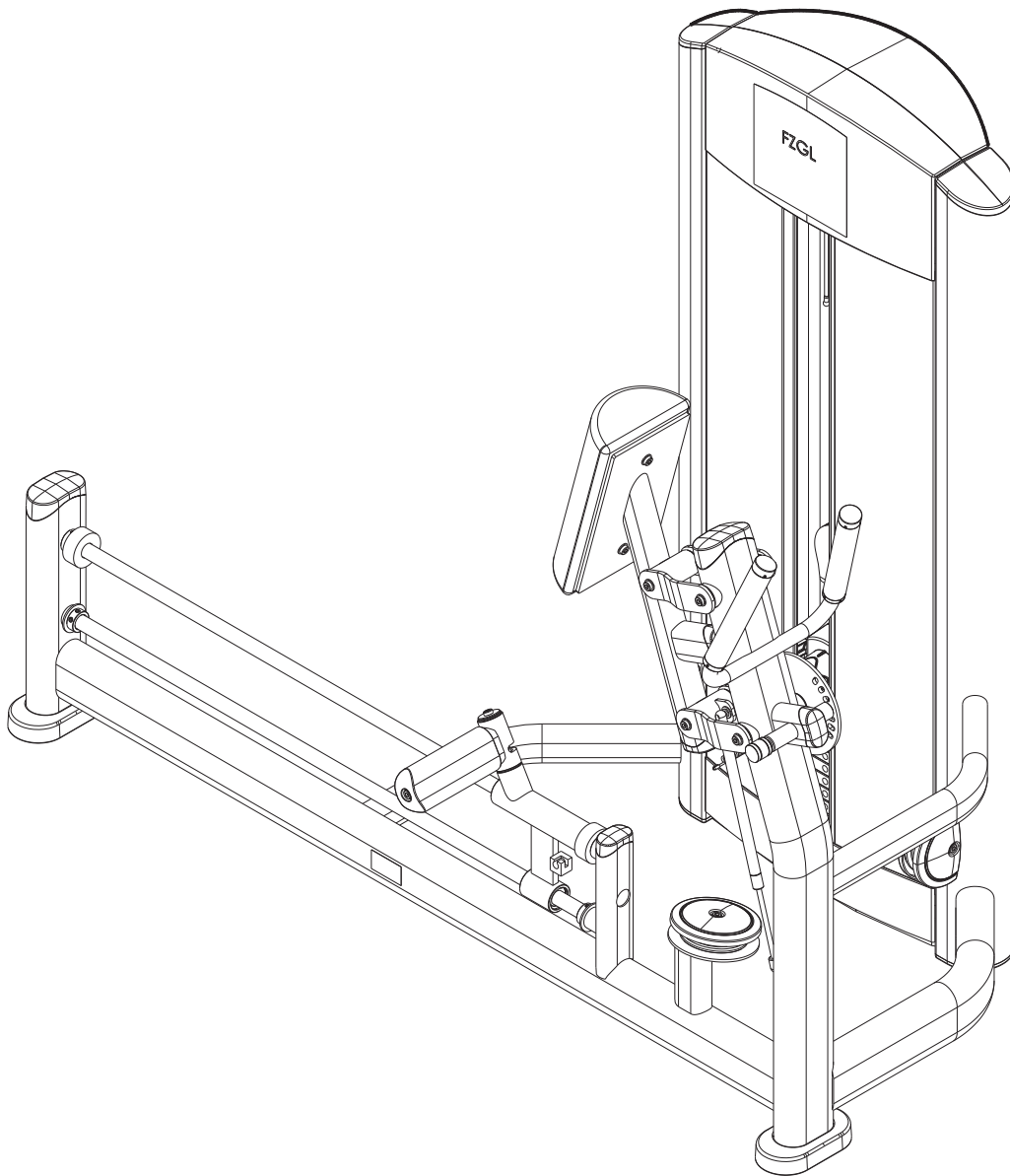

SIGNATURE SERIES
FZGL GLUTE



Customer Support Services
PARTS MANUAL

FZGL GLUTE CONTENTS

	PAGE
COMPONENT ASSEMBLY	3
COMPONENT ASSEMBLY II	4
COMPONENT ASSEMBLY LEGEND	5
MID-9 TOWER ASSEMBLY	6
PLASTIC TOWER ASSEMBLY	7
MID-9 WEIGHT STACK ASSEMBLY	8
5 LB. INCREMENT WEIGHT ASSEMBLY	9
10 LB. INCREMENT WEIGHT ASSEMBLY	10
15 LB. INCREMENT WEIGHT ASSEMBLY	11
HEAD PLATE ASSEMBLY	12
HEAD PLATE ASSEMBLY LEGEND	13
IMAGE	14

FZGL GLUTE COMPONENT ASSEMBLY

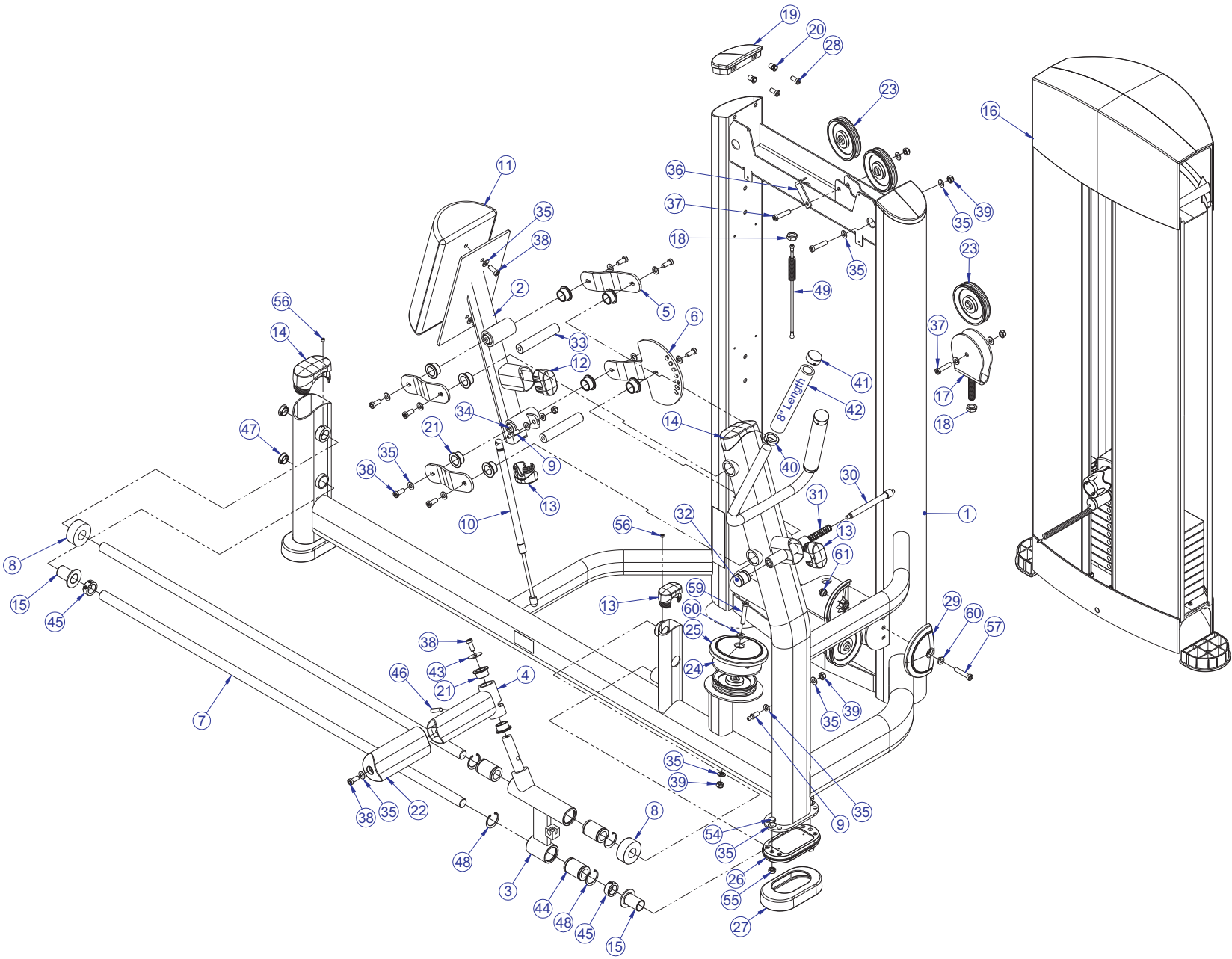

SEE PAGE 5 FOR LEGEND

FZGL GLUTE COMPONENT ASSEMBLY II

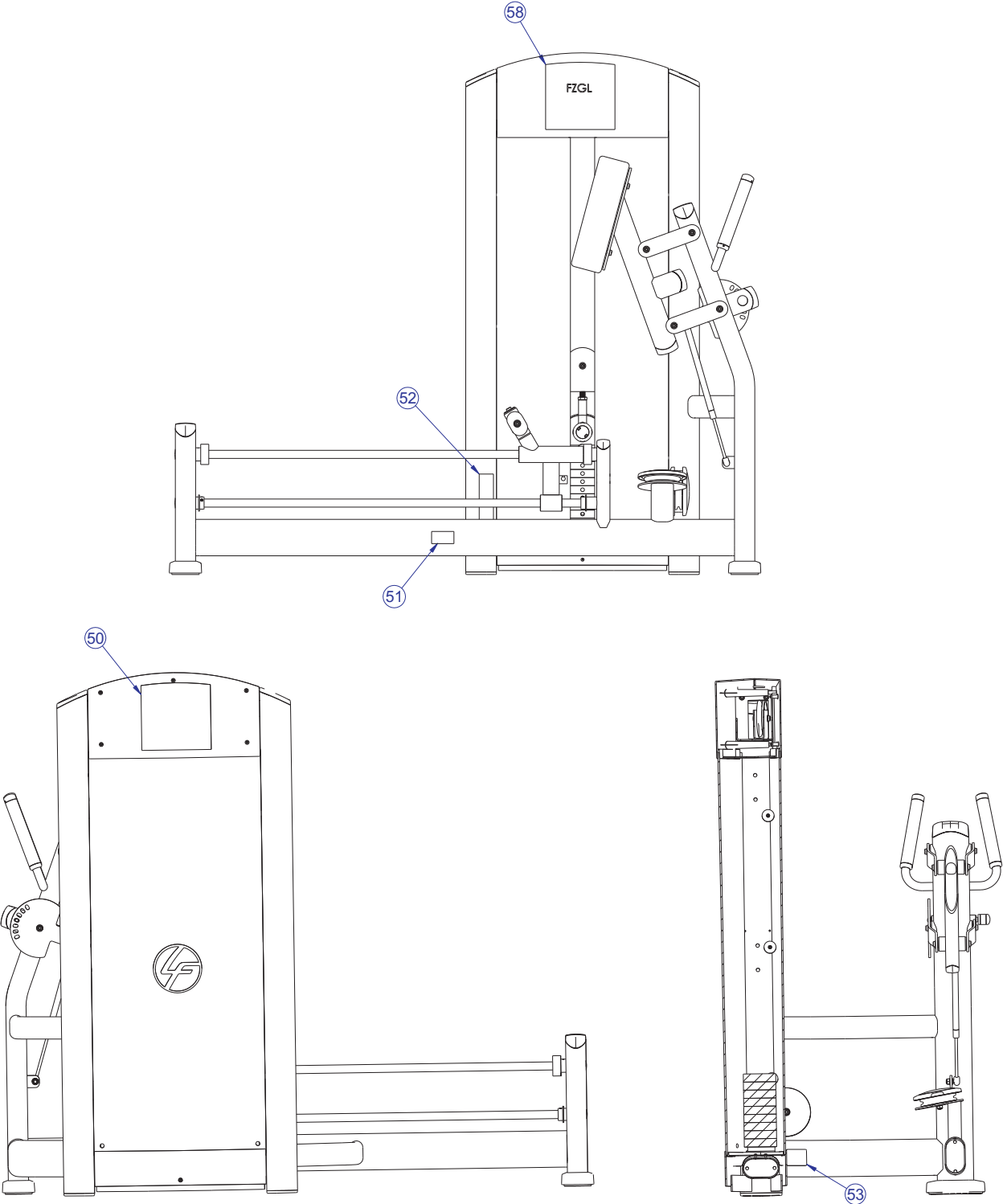

SEE PAGE 5 FOR LEGEND

FZGL GLUTE COMPONENT ASSEMBLY LEGEND

ITEM NO.	QTY.	PART NO.	DESCRIPTION
1	1	7617801	WLDMT, FZGL FRAME
2	1	7619401	WLDMT, FZGL CHEST SUPPORT
3	1	7619901	WLDMT, FZGL CART
4	1	7620401	WLDMT, FZGL FOOT BAR
5	3	7620701	BRKT, FZGL PIVOT LINK
6	1	7620801	BRKT, FZGL PIVOT ADJ LINK
7	2	7619801	GUIDE ROD, 1" DIA CASE X 52"
8	2	3108001	CUSHION, WEIGHT STACK
9	2	7414301	STUD, M10 BALL END M10 X 1.5
10	1	3235703	SPRING, GAS 80N
11	1	76264XX	PAD, LUMBAR, NO BACKER
12	1	7317901	STOP, BUMPER
13	3	7333801	CAP, SMALL FLOV- END
14	2	7333901	CAP, LARGE FLOV- END
15	2	6714901	BUSHING, GUIDE ROD 1 ID X 2
16	1	7420301	ASSY, MID TOWER-9
17	1	7625095	WLDMT, FZ WT STK PULLEY BRKT
18	2	3236902	NUT, M16 X 2 HEX JAM SS
19	2	7326201	CAP, D-TUBE - TOP
20	4	3238601	M10X1.5 THREADED INSERT (HEX)
21	10	3104903	1.00" ID 1.25" OD BRNZ BUSHING
22	1	7620901	SLEEVE, 1.63 X 2.75 FLOV
23	5	3237801	PULLEY, 4.5" OD
24	1	7318201	PLATE, PULLEY
25	1	8102901	COVER, PULLEY-BOLTED FULL
26	2	7334001	FOOT, 2.50 X 4.49 FLOV
27	2	7340201	COVER, FOOT - STRAIGHT
28	4	3236201	SCREW, M10 X1.5 20MM
29	2	8094101	COVER, PULLEY-BOLTED PARTIAL
30	1	7425102	PIN, PULL X 6.75
31	1	7351501	SPRING; PULL PIN LARGE
32	1	7424801	KNOB, POP PIN
33	2	7324902	SHAFT, TAPPED 1 DIA X 5.330
34	2	7324904	SHAFT, TAPPED 1 DIA X 3.580
35	25	3236601	WASHER, 3/8 SAE SS
36	1	6757701	CLIP, CABLE 2-7/8 X 1 X 1
37	3	3236206	SCREW, M10 X1.5 45MM
38	12	3236202	SCREW, M10 X1.5 25MM
39	6	3236801	NUT, M10 HEX NYLOCK SS
40	2	7662802	RING, GRIP 1.50 OD
41	2	7662902	CAP, GRIP 1.50 OD
42	2	3235802	GRIP, SHADOW GRAY, 8.00"
43	1	3236701	WASHER, FENDER 3/8" IDX1.5"OD
44	3	3245601	BEARING, LINEAR 1" ID
45	2	7435301	COLLAR, SHAFT 1.020 ID
46	1	3253501	PIN, GROOVE 3/8 DIA X 1-1/2
47	2	3237403	PLUG, 1" HOLE
48	4	3202601	RET RING, INT 1-3/4 DIA X1/16
49	1	7423719	CABLE, FZGL
50	1	7509801	LABEL, FZAB PLACARD
51	1	7422003	LABEL, MOVING PARTS
52	1	7422004	LABEL, 2" ASTM WARN
53	1	7571301	LABEL, SERIAL NUMBER
54	4	3251202	SCREW, M10 X1.5 X 25MM HEX Z
55	4	3254703	NUT, M10 X 1.5 HEX ZINC
56	2	3242901	SCREW, SET BO
57	1	3236207	SCREW, M10 X1.5 50MM
58	1	7509701	LABEL, FZGL PLACARD
59	1	3236208	SCREW, M10 X1.5 55MM
60	2	7630101	RETAINER, CM/MJ, PULLEY
61	1	7335401	NUT, M10 X 1.5 SOCKET HEAD

FZGL GLUTE MID-9 TOWER ASSEMBLY - 7420301

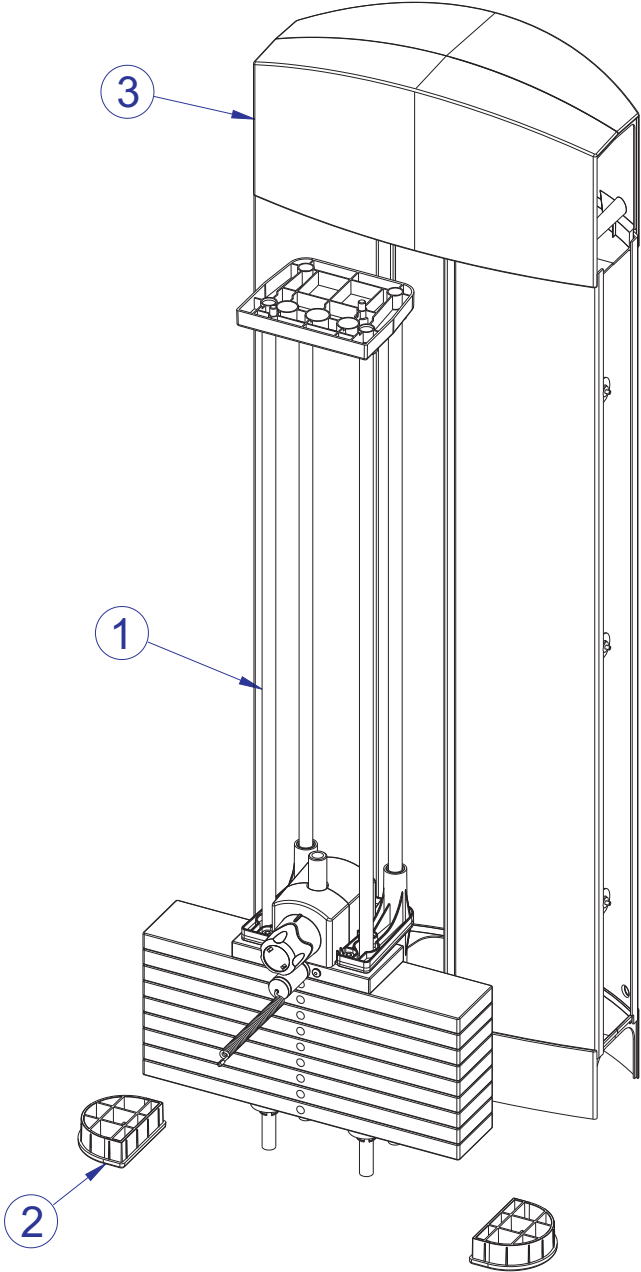

ITEM NO.	QTY.	PART NO.	DESCRIPTION
1	1	7420001	ASSY, WEIGHT STACK MID-9
2	2	7326301	CAP, D-TUBE-BTM
3	1	7419801	ASSY, TOWER PLASTICS-MID

FZGL GLUTE PLASTIC TOWER ASSEMBLY - 7419801

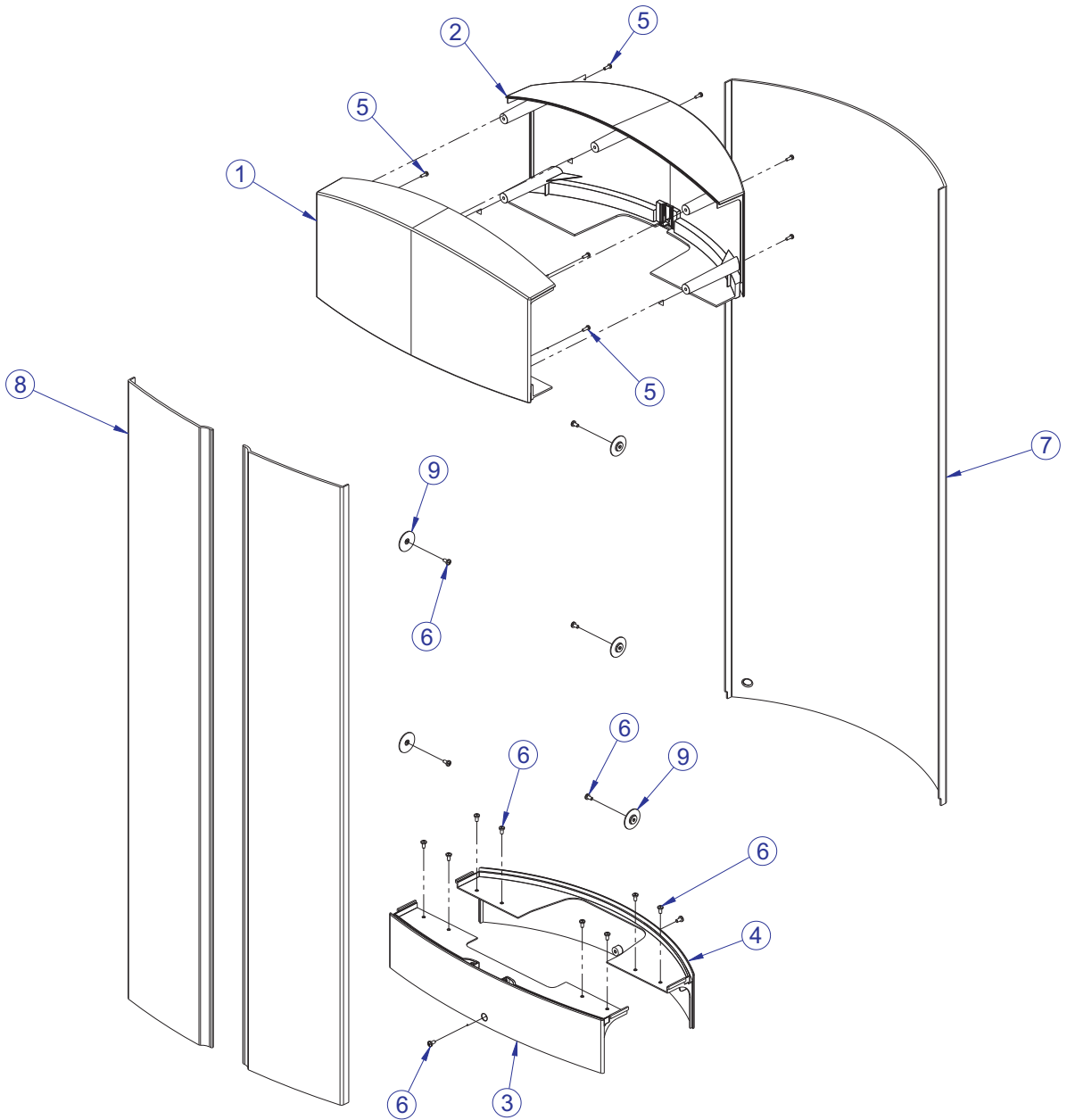

ITEM NO.	QTY.	PART NO.	DESCRIPTION
1	1	7318601	COVER, TOWER- TOP FRONT
2	1	7318701	COVER, TOWER- TOP REAR
3	1	7318801	COVER, TOWER- BOTTOM FRONT
4	1	7318901	COVER, TOWER- BOTTOM REAR
5	9	3236501	M4 X 0.7 PHL PAN MS ST ZN
6	16	3239101	SCREW, M5X10 PHL PAN TT ST
7	1	7765701	SHROUD, TOWER- REAR SHORT
8	2	7765601	SHROUD, TOWER- FRT SHORT RH
9	6	7583501	RETAINER, FZ SHROUD

FZGL GLUTE MID-9 WEIGHT STACK ASSEMBLY - 7420001

WEIGHT STACK LABELS

7927201	LABEL, 390 LB STACK
7927301	LABEL, 195 KG STACK

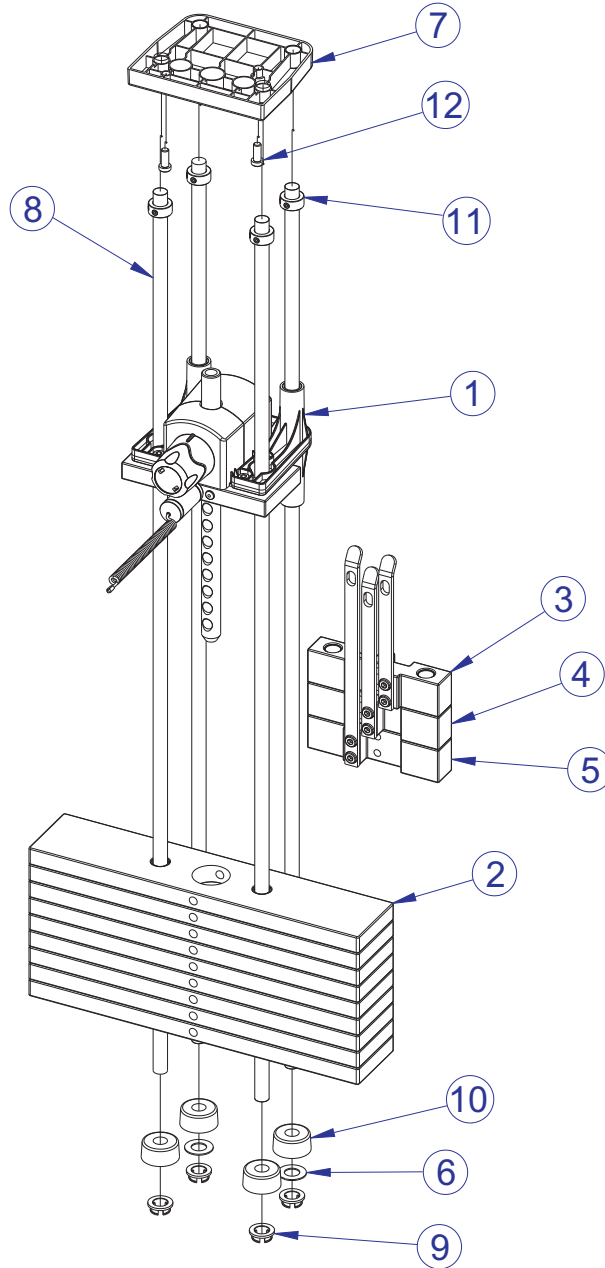

ITEM NO.	QTY.	PART NO.	DESCRIPTION
1	1	7350601	ASSY, HEAD PLATE (9)
2	9	7328401	WEIGHT PLATE, 20 LB
3	1	7327601	ASSY, INCREMENT WT-5LB
4	1	7327701	ASSY, INCREMENT WT-10LB
5	1	7327801	ASSY, INCREMENT WT-15LB
6	2	7351001	SPACER, INC WT STACK
7	1	7621101	RETAINER, GUIDE ROD-TOP
8	4	7328602	GUIDE ROD, .75 OD SOLID X 53.50
9	4	7337901	BUSHING, GUIDE ROD
10	4	7352101	CUSHION, WEIGHT STACK
11	4	3103301	SHAFT COLLAR, 3/4" ID ZINC
12	2	3236202	M10 X 1.5 X 25 HXS SOC CS SS

FZGL GLUTE

5 LB. INCREMENT WEIGHT ASSEMBLY - 7327601

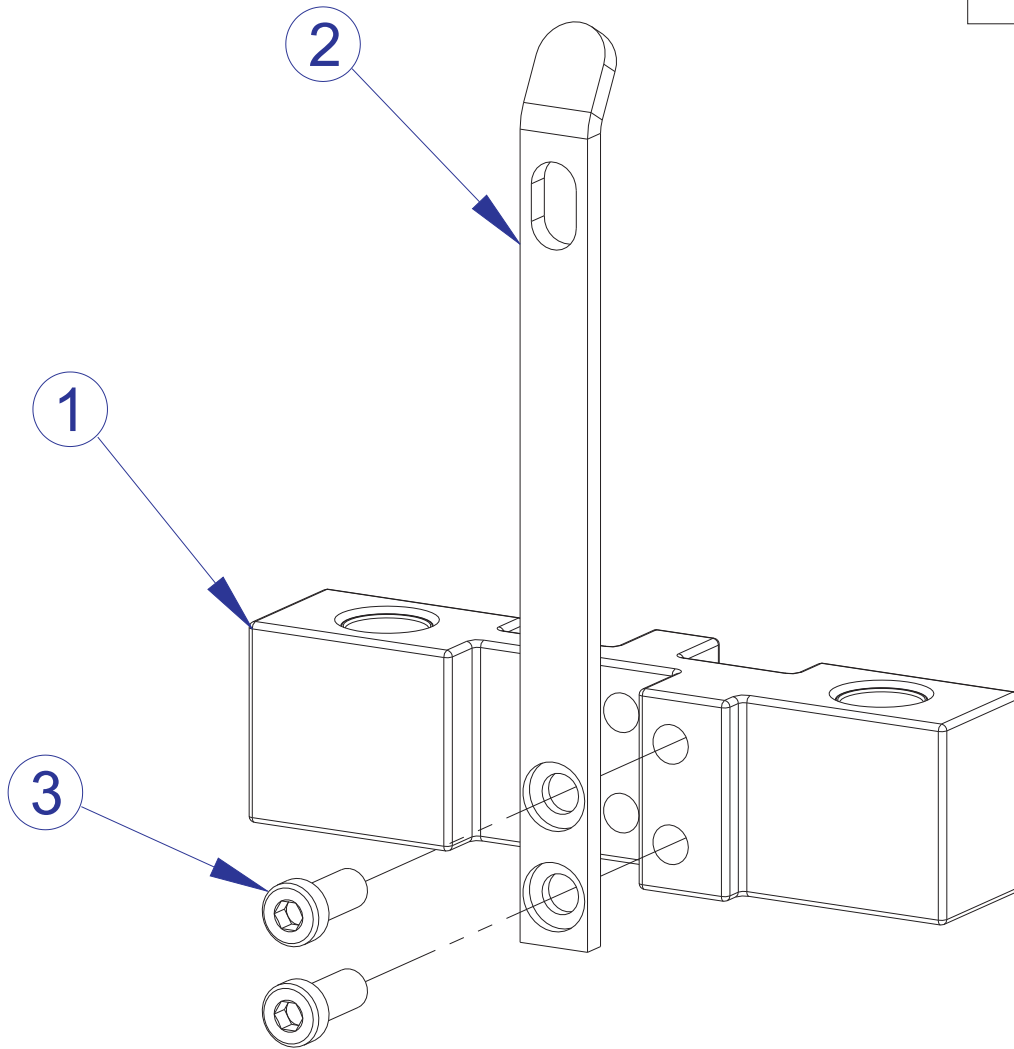
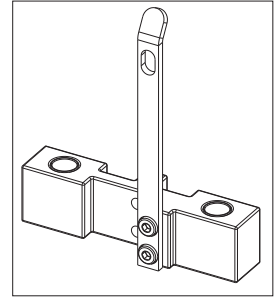

ITEM NO.	QTY.	PART NO.	DESCRIPTION
1	1	7968501	ASSY, FZ INC WEIGHT 5LB
2	1	7328001	BRKT, INCREMENT WT - 5 LB
3	2	3236202	SCREW, M10 X1.5 25MM

FZGL GLUTE

10 LB. INCREMENT WEIGHT ASSEMBLY - 7327701

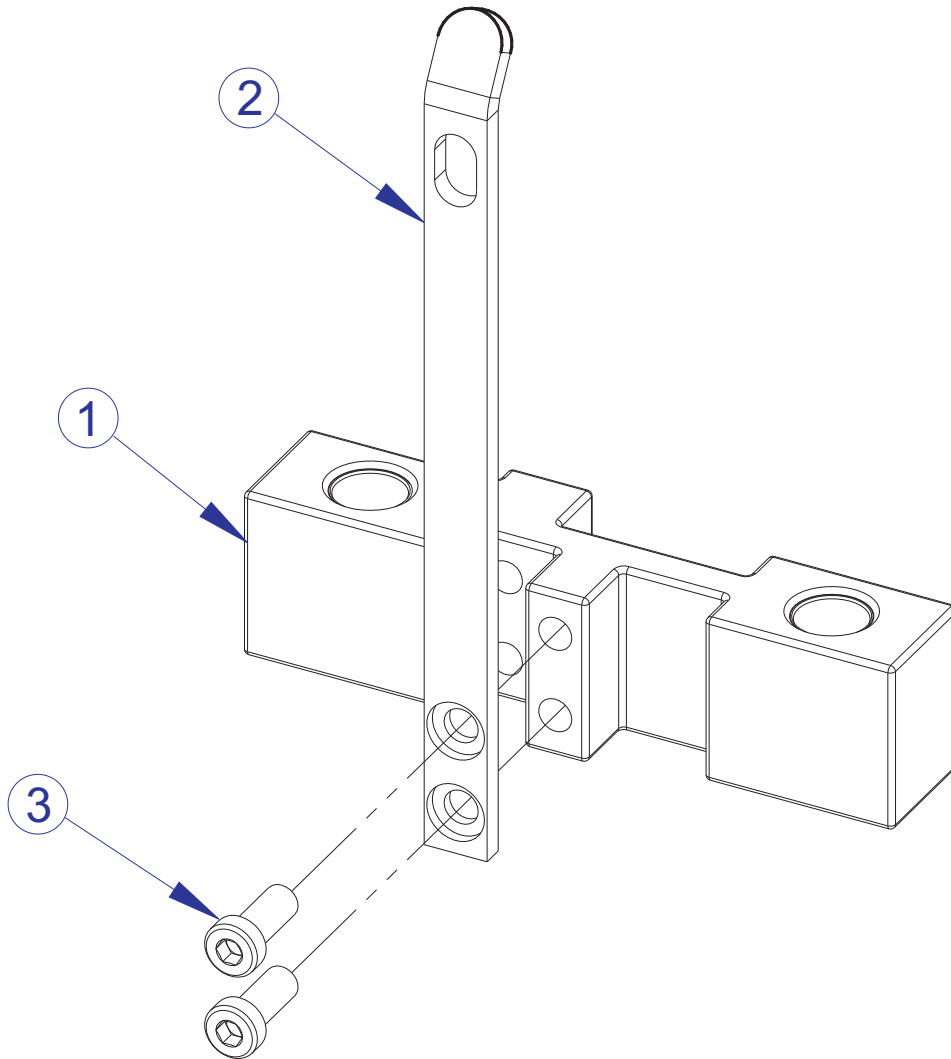
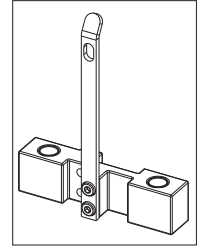

ITEM NO.	QTY.	PART NO.	DESCRIPTION
1	1	7968501	ASSY, FZ INC WEIGHT 5LB
2	1	7328101	BRKT, INCREMENT WT - 10 LB
3	2	3236202	SCREW, M10 X1.5 25MM

FZGL GLUTE

15 LB. INCREMENT WEIGHT ASSEMBLY - 7327801

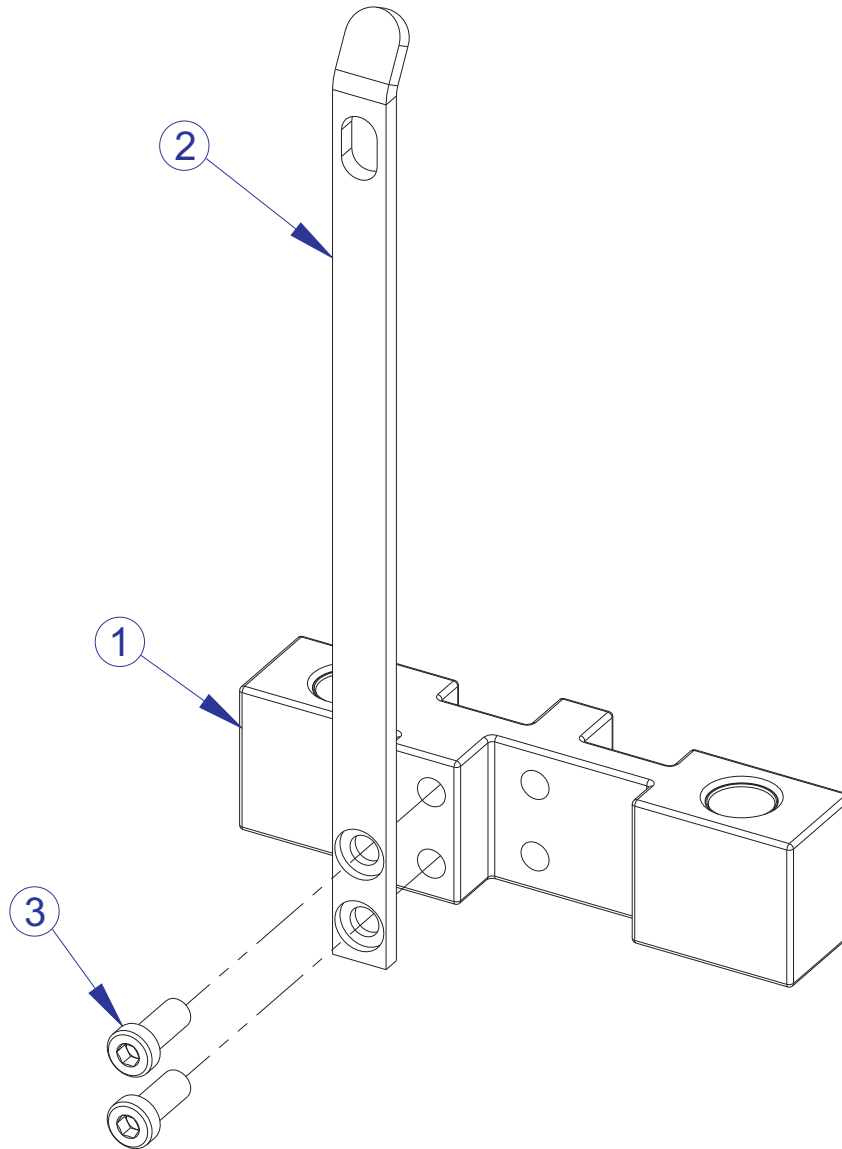
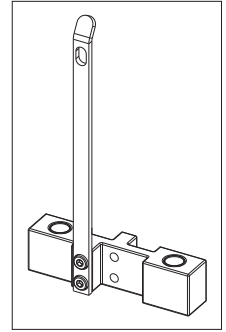

ITEM NO.	QTY.	PART NO.	DESCRIPTION
1	1	7968501	ASSY, FZ INC WEIGHT 5LB
2	1	7328201	BRKT, INCREMENT WT - 15 LB
3	2	3236202	SCREW, M10 X1.5 25MM

FZGL GLUTE HEAD PLATE ASSEMBLY - 7350601

WEIGHT STACK LABELS

7927201	LABEL, 390 LB STACK
7927301	LABEL, 195 KG STACK

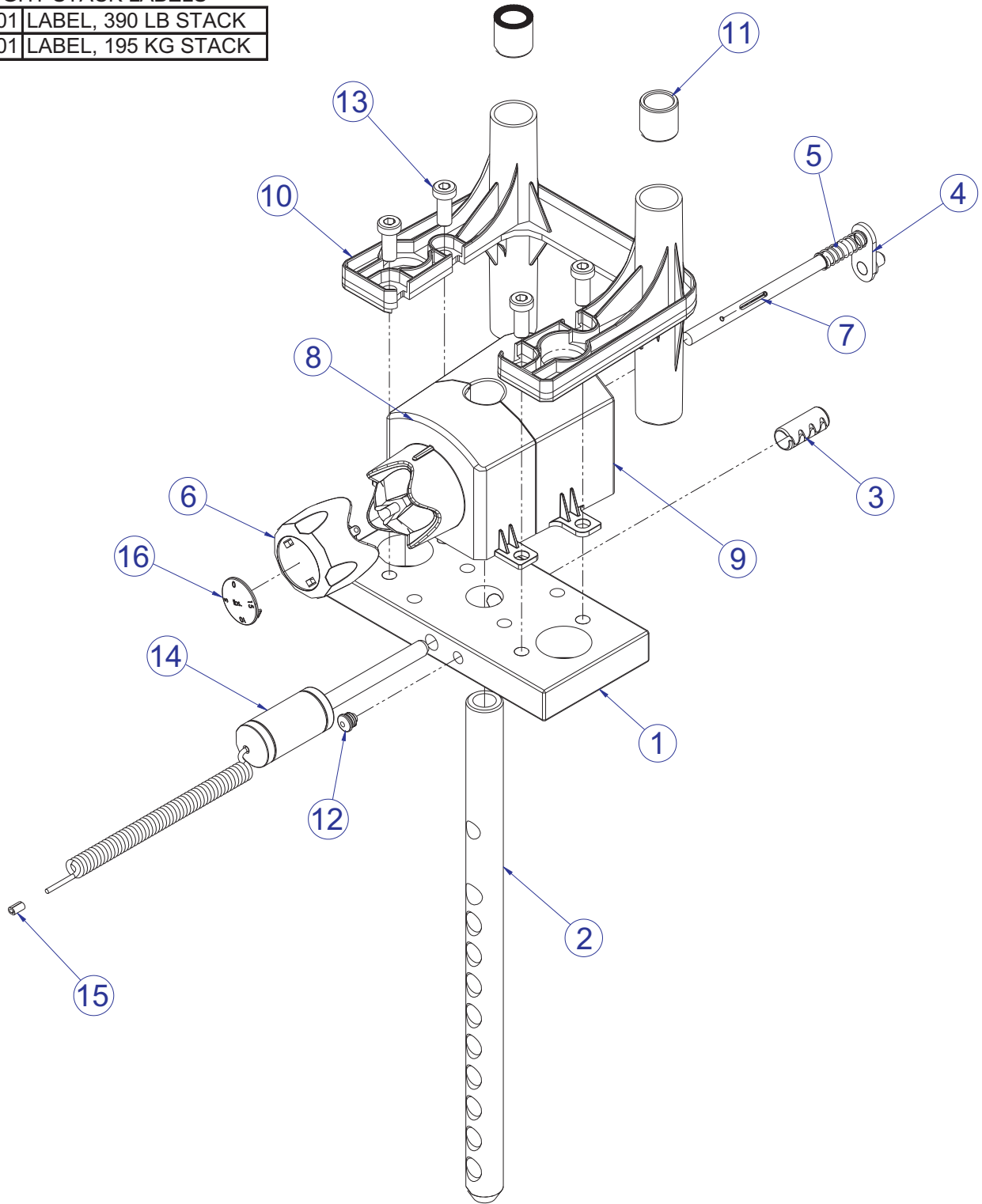

SEE PAGE 13 FOR LEGEND

FZGL GLUTE HEAD PLATE ASSEMBLY LEGEND

ITEM NO.	QTY.	PART NO.	DESCRIPTION
1	1	7326701	HEAD PLATE
2	1	7347801	STEM, 9 PLATE
3	1	3236001	BUSHING, SPRING PIN
4	1	7327201	WLDMT, INCREMENT WT PIN
5	1	8024501	SPRING, 1/2 OD X 1-1/2
6	1	7326101	KNOB, INC WT SELECTOR
7	1	3110008	ROLL PIN, 1/8 X 1-1/4
8	1	7326401	HOUSING, SELECTOR - FRONT
9	1	7326501	HOUSING, SELECTOR - REAR
10	1	7362101	STABILIZER, HEAD PLATE
11	4	7459601	BUSHING, HEAD PLT STABILIZER
12	1	7356501	PLUG, LANYARD ATTACHMENT
13	4	3236202	SCREW, M10 X1.5 25MM
14	1	7338101	ASSY, WT STACK SELECTOR PIN
15	1	7523601	CRIMP, CABLE
16	1	7398601	CAP, SELECTOR KNOB, LBS
	OR		
	1	7398701	CAP, SELECTOR KNOB, KG

FZGL GLUTE
IMAGE

