

CA3000C & CA6000C



Cartridge Air Cleaners



TRION[®]
air purification systems

CA3000C & CA6000C



ENGINEERED SOLUTIONS FOR CLEAN AIR

Trion's CA3000C and CA6000C Cartridge Air Cleaners used in either source capture or unducted applications will help solve heavy welding smoke, dust and other indoor air pollution problems. They have been designed for high-efficiency, self-cleaning, easy serviceability, and long filter life.

FEATURES/BENEFITS

- 4 or 9 Long-Life Filter Cartridges - provide up to 99% efficiency. Cartridges have 8 times more surface collecting area than comparable bag media type air cleaners, resulting in greater dirt-holding capacity and longer filter life
- In-place, cartridge cleaning utilizing compressed air - minimizes maintenance and reduces downtime
- Each filter is pulsed independently - better cleaning of cartridge during cleaning cycle
- 3 Pulse Options
 - Manual Pulse - initiate when desired
 - Timed Pulse with 7 Day-Clock - initiate at predetermined intervals
 - "On Demand" Sensed Pulse - initiate at set static pressure
- Side Access Doors - simplifies maintenance and cartridge removal
- Backward-inclined Airfoil Fan - energy efficient and quiet operation



HOW IT WORKS

Trion's CA3000C and CA6000C Cartridge Air Cleaners pull the dirty, polluted air through the high-efficiency cellulose pleated cartridge filters where the particulate is collected on the outside of the media. The filtered air then passes through the clean air plenum and is exhausted.

To clean the cartridges: clean, dry, compressed air is connected, and the timer (which is actuated either manually or automatically) sequentially opens and closes air valves. The valves direct pulses or bursts of compressed air from the inside to the outside of the cartridge. This pulsing action dislodges the collected contaminants from the filters. The contaminants then fall to the bottom of the unit or into the hopper (optional accessory).

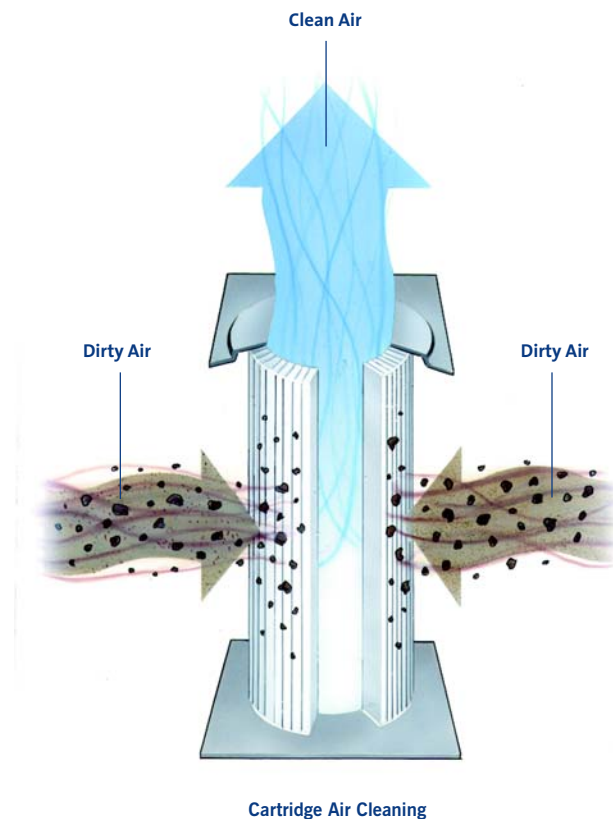

APPLICATIONS

For industrial work environments, Trion Cartridge Air Cleaners are excellent for applications where heavy smoke, powders, and dust create unhealthy and hazardous environments.

Specifications

	CA3000C	CA6000C																								
Cabinet	11 & 16 gauge welded galvanized steel	11 & 16 gauge welded galvanized steel																								
Color/Finish	Pearl white epoxy, baked on, oil resistant	Pearl white epoxy, baked on, oil resistant																								
Air Flow	Horizontal - Right to Left or Left to Right - Standard, Side Discharge - Optional	Horizontal - Right to Left or Left to Right - Standard, Side Discharge - Optional																								
Dimensions	68" L x 46" W x 35" H	99" L x 49" W x 53" H																								
Installation	Suspended or Frame mounting	Suspended, Wall, or Frame mounting																								
Unit Wt.	750 lbs., Shipping Wt: 890 lbs. (Standard unit)	1,100 lbs., Shipping Wt. 1,400 lbs. (Standard unit)																								
Motor Description	TEFC, ball bearing, 3,450 RPM, continuous duty, U.L. Listed	TEFC, ball bearing, 1,750 RPM, continuous duty, U.L. Listed																								
Motor	<table border="1"> <thead> <tr> <th>HP</th> <th>VAC</th> <th>Hz</th> <th>Phase</th> <th>Amp.Max</th> <th>Watts Max</th> </tr> </thead> <tbody> <tr> <td>5</td> <td>208/230/460</td> <td>60</td> <td>3</td> <td>13.3/12.0/6.0</td> <td>4,288</td> </tr> </tbody> </table>	HP	VAC	Hz	Phase	Amp.Max	Watts Max	5	208/230/460	60	3	13.3/12.0/6.0	4,288	<table border="1"> <thead> <tr> <th>HP</th> <th>VAC</th> <th>Hz</th> <th>Phase</th> <th>Amp. Max</th> <th>Watts Max</th> </tr> </thead> <tbody> <tr> <td>7.5</td> <td>208/230/460</td> <td>60</td> <td>3</td> <td>22.8/20.6/10.3</td> <td>7,098</td> </tr> </tbody> </table>	HP	VAC	Hz	Phase	Amp. Max	Watts Max	7.5	208/230/460	60	3	22.8/20.6/10.3	7,098
HP	VAC	Hz	Phase	Amp.Max	Watts Max																					
5	208/230/460	60	3	13.3/12.0/6.0	4,288																					
HP	VAC	Hz	Phase	Amp. Max	Watts Max																					
7.5	208/230/460	60	3	22.8/20.6/10.3	7,098																					
Motor Sheave	N/A	Variable pitch																								
Blower	Direct drive backward inclined airfoil blower wheel	Belt driven backward inclined airfoil blower wheel																								
Air Volume	See blower curve	See blower curve																								
General	<p>Throw distance: To 80-ft.</p> <p>Filter Access: Hinged side doors with sealing gaskets and easy open latches - no tools required</p> <p>Side mounted pre-wired electrical junction box for valve connections</p>	<p>Throw distance: To 80-ft.</p> <p>Filter Access: Hinged side door with sealing gaskets and easy open latches - no tools required</p> <p>Side mounted pre-wired electrical junction box for valve connections</p>																								
Sound Rating	72 dBA	72 dBA																								
Pre-Filter	Aluminum mesh, Impinger or Perforated Plate	Aluminum mesh or Perforated Plate																								
Main Filter	<p>4-Cellulosic pleated cartridge filters</p> <p>226 sq. ft. each filter area</p> <p>Efficiency to 99.9% @ 0.5 micron</p> <p>Other filter media cartridges available</p>	<p>9-Cellulosic pleated cartridge filters</p> <p>226 sq. ft. each filter area</p> <p>Efficiency to 99.9% @ 0.5 micron</p> <p>Other filter media cartridges available</p>																								
Plenum Options	<p>Source capture with 14" round starting collar</p> <p>Source capture with dual arm feature</p>	Source capture with 20" round starting collar																								
Optional Accessories	<p>Filter change indicator gauge</p> <p>Automatic pulse control (photohelic switch/gauge)</p> <p>7-Day time clock pulse control</p> <p>Hopper assembly</p> <p>55-gallon drum lid cover</p> <p>4-way diffuser for directional air discharge</p>	<p>Filter change indicator gauge</p> <p>Automatic pulse control (photohelic switch/gauge)</p> <p>7-Day time clock pulse control</p> <p>Hopper assembly</p> <p>55-gallon drum lid cover</p> <p>4-way diffuser for directional air discharge</p>																								
Pulse System	<p>Sequential pulse timer control (115v Single Phase)</p> <p>4 each - 3/4" valves</p> <p>Compressed air required: 90 PSIG. 1.11 SCF/Pulse</p>	<p>Sequential pulse timer control (115v Single Phase)</p> <p>9 each - 3/4" valves</p> <p>Compressed air required: 90 PSIG. 1.11 SCF/Pulse</p>																								

CA3000C TECHNICAL DRAWINGS

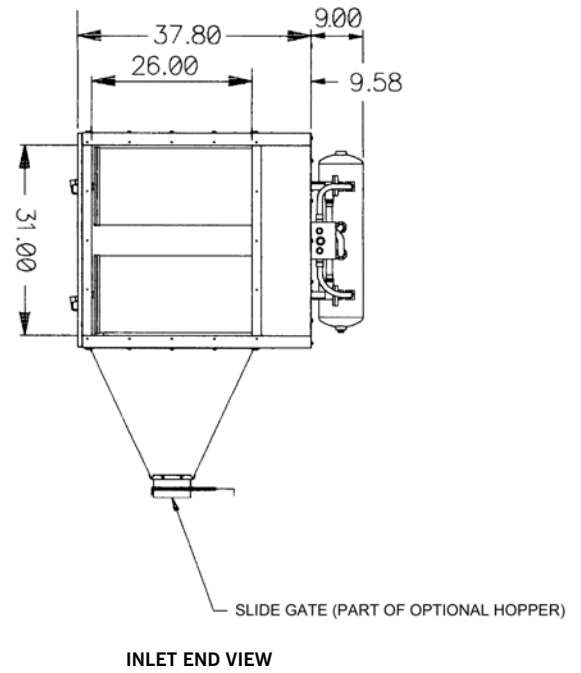
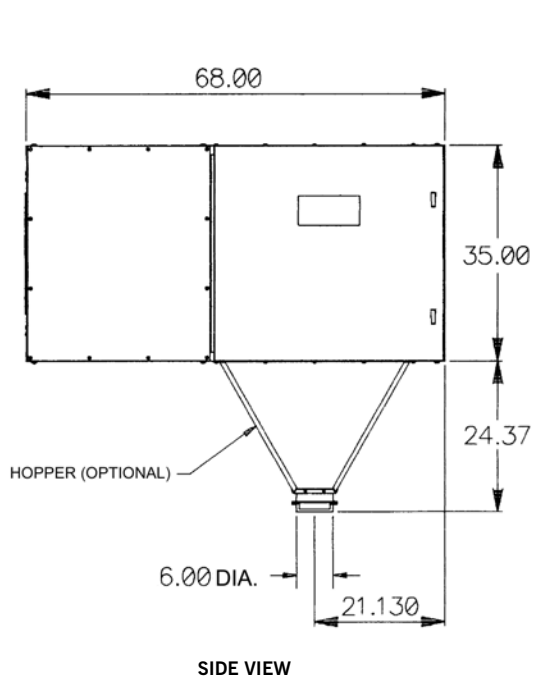
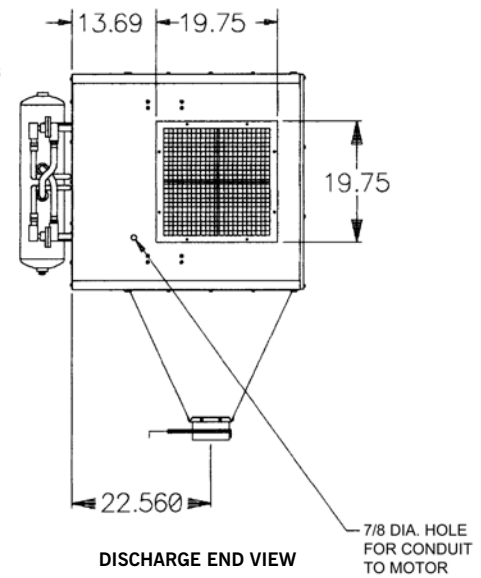
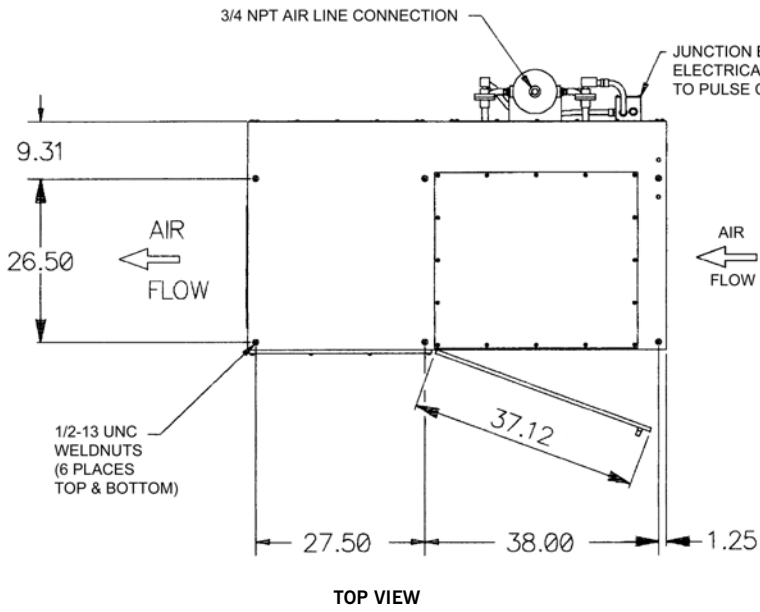

CA3000C Blower Curves

STANDARD BLOWER ASSEMBLY DIRECT DRIVE

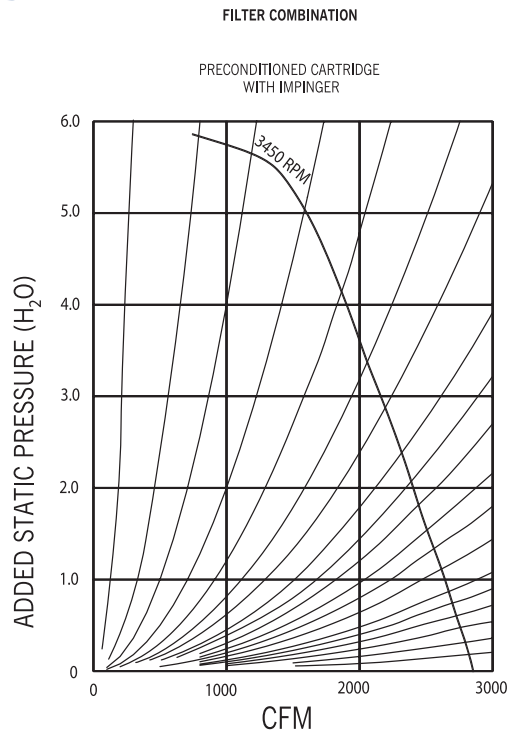
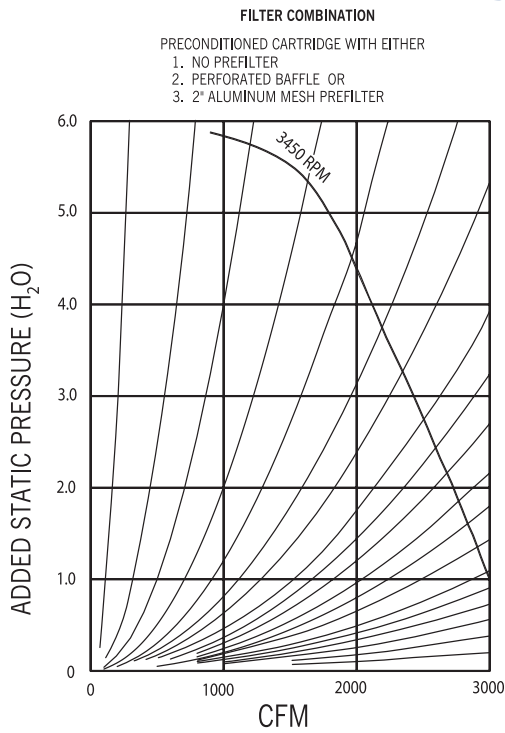

HIGH STATIC BLOWER ASSEMBLY DIRECT DRIVE

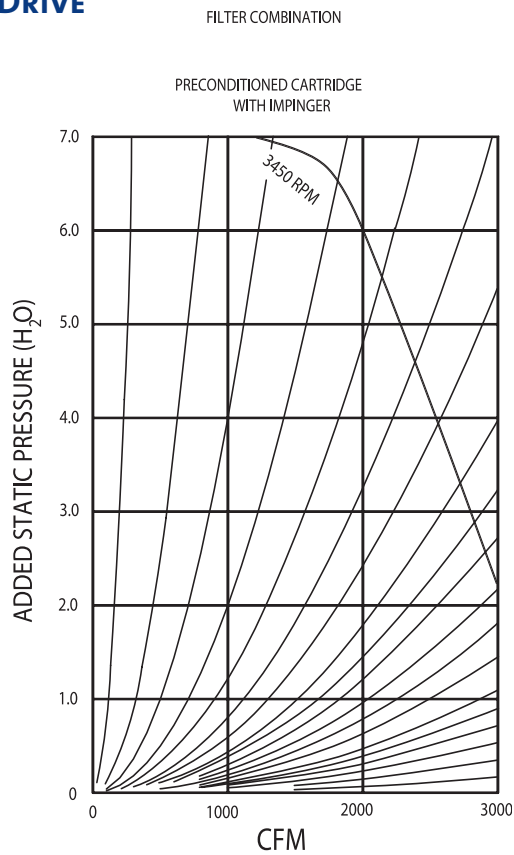
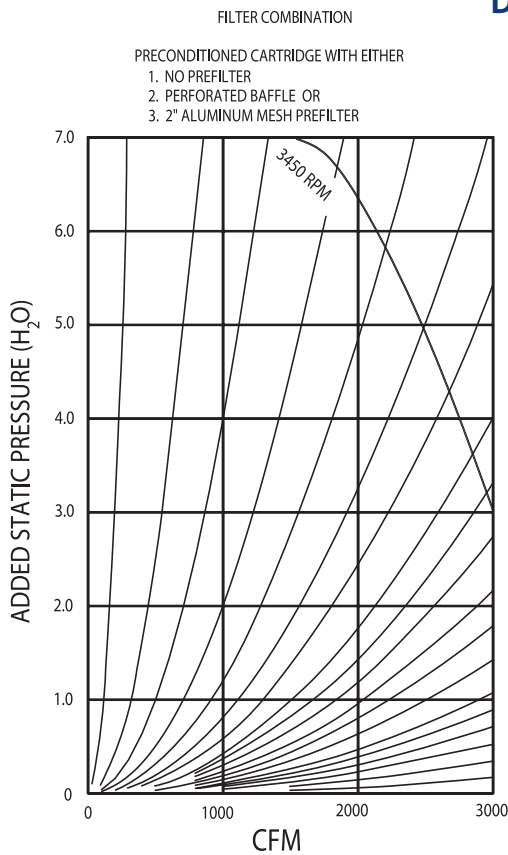

CA6000C TECHNICAL DRAWINGS

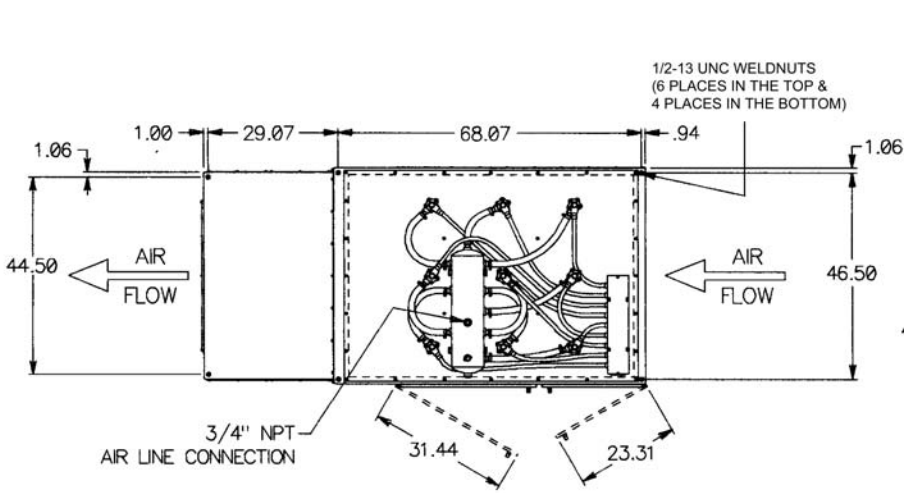

TOP VIEW

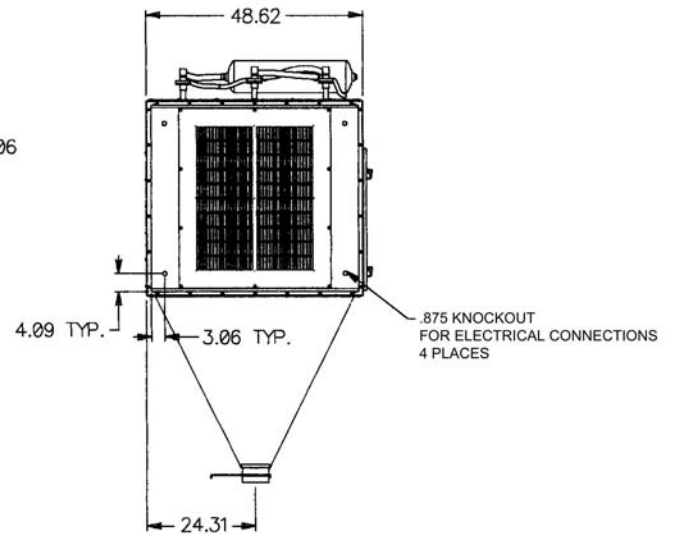

DISCHARGE END VIEW

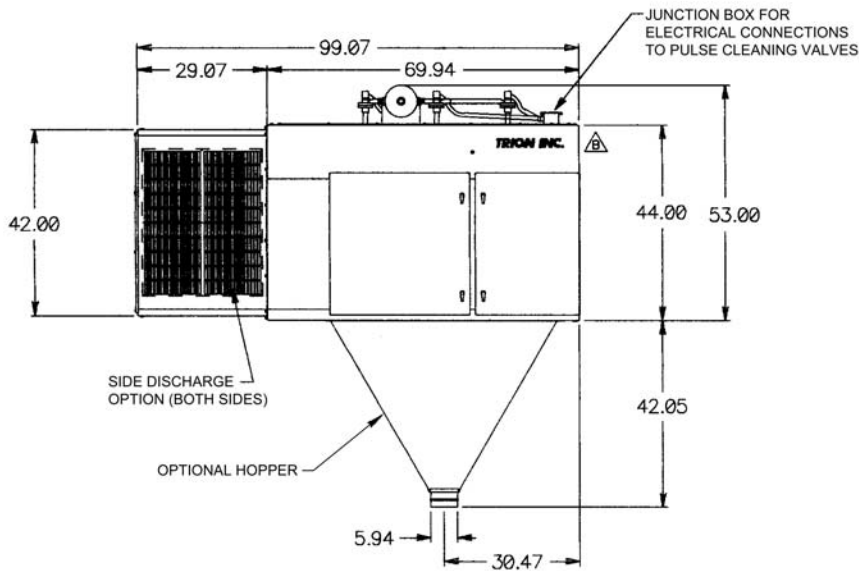

SIDE VIEW

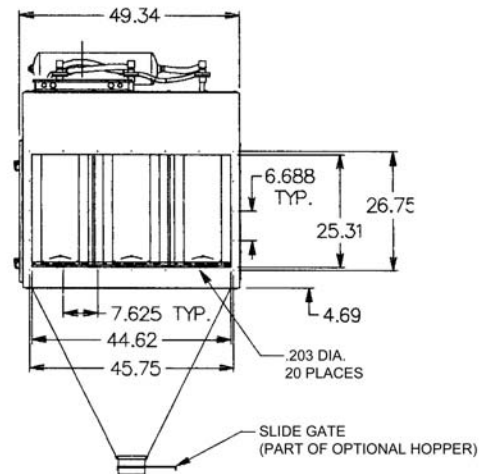

INLET END VIEW

CA6000C Blower Curve

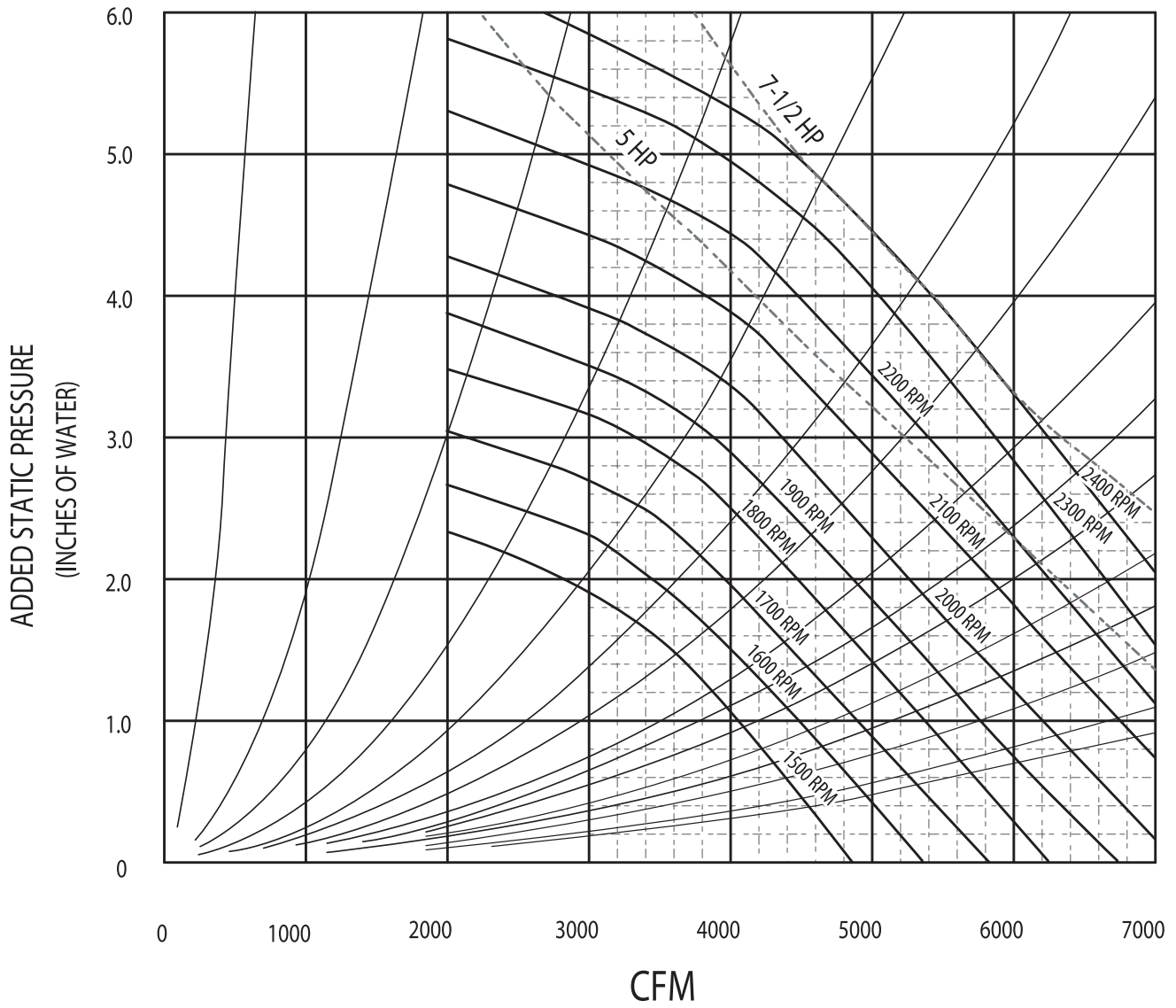



Headquartered in Sanford, North Carolina

Leading Technology for Cleaner Exhaust Air Since 1947

TRION[®]
Air Purification Systems