



# INSTALLATION INSTRUCTIONS FOR PART 99-5719

# INSTALLATION INSTRUCTIONS FOR PART 99-5719

## APPLICATIONS FORD TAURUS 2004 - 2007 99-5719

### KIT FEATURES

- ISO & DIN Head Unit Provision w/ Pocket
- DDIN Head unit provisions
- Integrated auto climate controls and display
- Integrated passenger airbag light
- Painted Scratch Resistant Matte Black



### KIT COMPONENTS

- A) Radio Housing • B) ISO Brackets • C) ISO Trim Plate • D) Pocket
- E) DDIN Brackets • F) DDIN Trim Plate • G) In-Car Temp Sensor Housing • H) Harness Extension

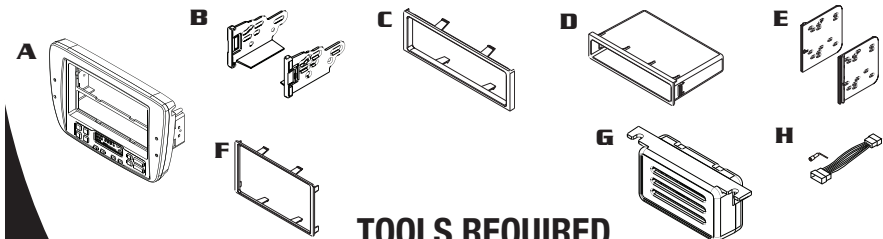

### TOOLS REQUIRED

- Radio Removal Tool (Metra Part #86-5618) • Phillips Screwdriver
- Panel Removal Tool • Socket Set • Cutting Tool or File • T10 Torx Screwdriver



REV. 1/20/2010

**METRA. THE WORLD'S BEST KITS.™**



**1-800-221-0932**



**metraonline.com**

© COPYRIGHT 2004-2010 METRA ELECTRONICS CORPORATION

**METRA. THE WORLD'S BEST KITS.™**



**1-800-221-0932**



**metraonline.com**

© COPYRIGHT 2004-2010 METRA ELECTRONICS CORPORATION



99-5719

99-5719

# TABLE OF CONTENTS

# NOTES

## DASH DISASSEMBLY

- FORD TAURUS 2004 - 2007 . . . . . 1

## KIT PREPARATION

- FORD TAURUS 2004 - 2007 . . . . . 2

## KIT ASSEMBLY

- FORD TAURUS 2004 - 2007 . . . . . 3-6

**\*NOTE:** This product has software that can be flashed via the AXCESS USB-CAB cable and AXCESSINTERFACE.COM. Please contact the Metra tech support team if you feel this product is not performing properly.

**\*NOTE:** Refer Also to the instructions included with the aftermarket radio.

---

---

---

---

---

---

---

---

---

---

---

---

---

---

---

---

---

---

---

---

---

---

---

---



### KNOWLEDGE IS POWER

Enhance your installation and fabrication skills by enrolling in the most recognized and respected mobile electronics school in our industry. Log onto [www.installerinstitute.com](http://www.installerinstitute.com) or call 800-354-6782 for more information and take steps toward a better tomorrow.



**Metra recommends MECP certified technicians**



## FORD TAURUS 2004- 2007

- 1 Remove the In-Car temp sensor housing from the back of the factory control panel. Insert into the included In-Car temp sensor housing and mount the assembly under the dash.
- 2 Remove the factory rear support in the sub-dash. (Fig. A)

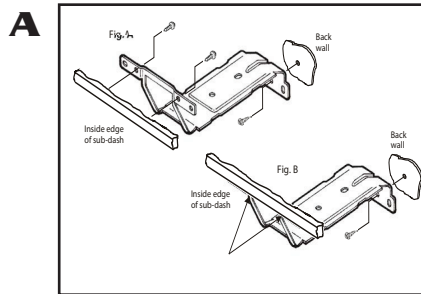

Continue to Kit Assembly

## FORD TAURUS 2004- 2007

### AUDIO WIRING

Open the trunk, remove (4) pop-clips from the driver's side trunk liner and remove the liner. (see Fig. A) locate the factory tuner on the wall of the trunk and disconnect the speaker and antenna plugs (it is NOT necessary to remove the tuner). (see Fig. B). Plug the 70-5715 into the unit speaker plug and the antenna extension lead into the unit antenna plug. Slide the extension harness through the space in the back seat between the seat back and seat bottom. Unclip the rocker trim, tuck the extension harness under the carpet and stretch the harness to the back of the dash. (Replace the rocker trim when completed). Splice the speaker leads on the extension harness into the rear of the aftermarket head unit. Plug the factory wiring harnesses into the switch connectors (previously mounted in step #2) and audio connectors on the back of the Integrated Mounting Kit.

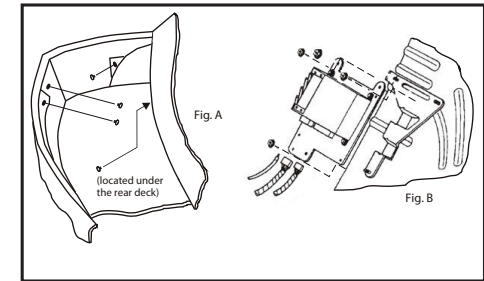

## FORD TAURUS 2004- 2007 DDIN/STACKED ISO DIN HEAD UNIT PROVISION

..... Continued from Pg.5

**5**

Snap the double DIN trim plate into the radio housing. (Fig. B)

Continue to "Audio Wiring" .....

**B**

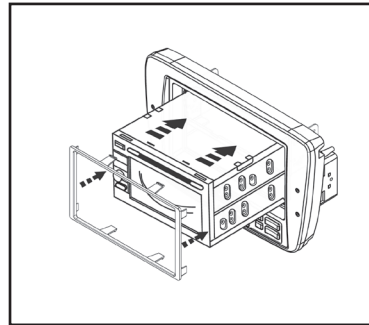

## FORD TAURUS 2004- 2007 DIN HEAD UNIT PROVISION

- 1** Locate the factory wiring harness in the dash. Metra recommends using the proper mating adapters (included) from Metra and AXXESS to integrate your new radio. Re-connect the negative battery terminal and test the unit for proper operation.

**A**

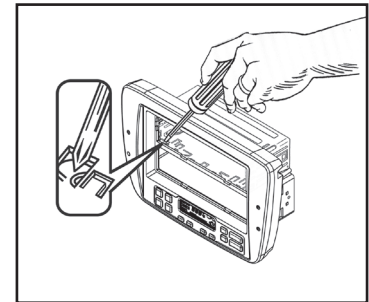

- 2** Slide the DIN cage into the Radio Housing and secure by bending the metal locking tabs down. (Fig. A)

**B**

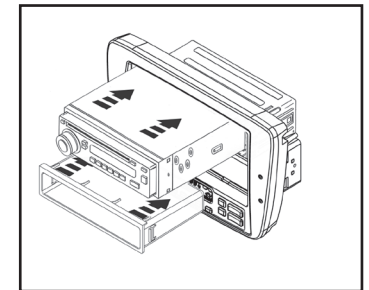

- 3** Snap the pocket into the bottom opening of the radio housing. (Fig. B)

- 4** Slide the aftermarket head unit into the cage and secure. (Fig. B)

Continue to "Audio Wiring"....

99-5719

99-5719

## FORD TAURUS 2004- 2007 ISO DIN HEAD UNIT PROVISION

- 1 Locate the factory wiring harness in the dash. Metra recommends using the proper mating adapters (included) from Metra and AXXESS to integrate your new radio. Reconnect the negative battery terminal and test the unit for proper operation.

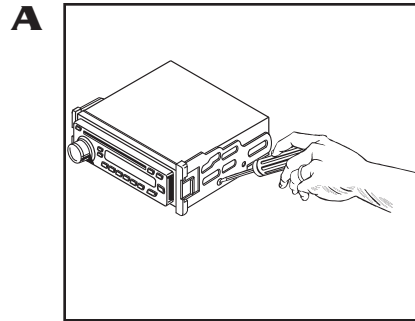

- 2 Mount the ISO Brackets to the head unit with the screws supplied with the unit. (Fig. A)

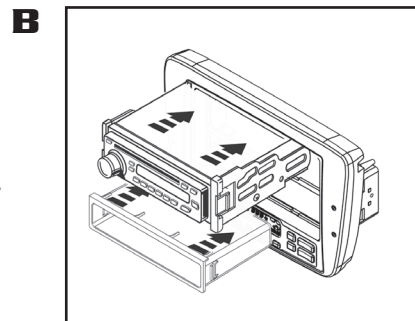

- 3 Snap the pocket into the bottom opening of the radio housing. (Fig. B)

- 4 Slide the head unit into the radio opening until the side clips engage. (Fig. B)

- 5 Snap the Trim plate into the Radio Housing.

Continue to "Audio Wiring"....

## FORD TAURUS 2004- 2007 DDIN/STACKED ISO DIN HEAD UNIT PROVISION

- 1 Locate the factory wiring harness in the dash. Metra recommends using the proper mating adapters (included) from Metra and AXXESS to integrate your new radio. Reconnect the negative battery terminal and test the unit for proper operation.

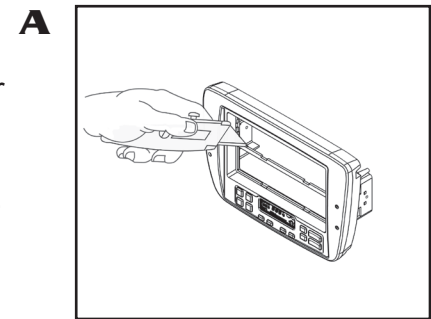

- 2 Cut and remove the center bar from the radio housing. (Fig.A)

- 3 Snap the Double DIN brackets to the inside edge of the Double DIN trim plate.

- 4 Slide the Double DIN head unit or stacked ISO head units into the bracket/radio housing assembly and secure the Double DIN head unit or stacked ISO head units to the assembly using the screws supplied with the radio. (Fig. B)

Continued on Pg. 6