

Overview

The UDM-0102 Endeleo Multi-format Distribution Mini-Hub (FG-UDM-0102) is designed for small installations with long video/audio cable runs (FIG. 1).

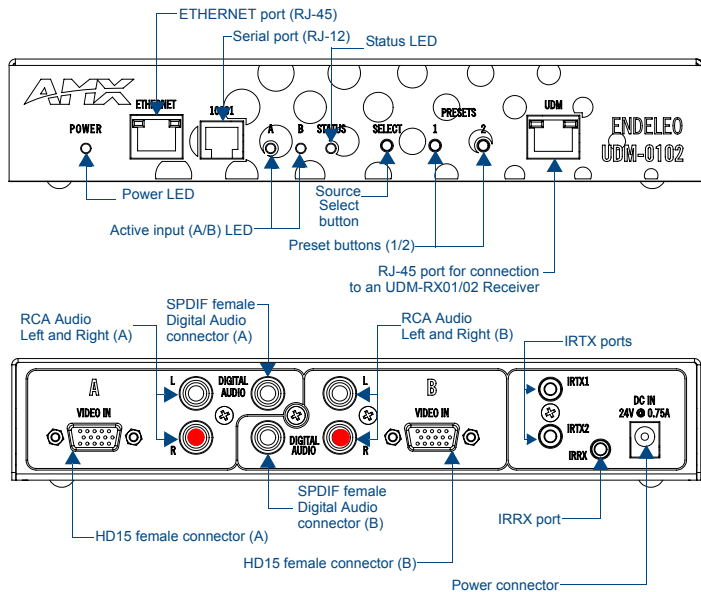

FIG. 1 UDM-0102 Hub - Front and Rear panel components

Compatibility

The UDM-0102 is compatible for use with the UDM-RX02 (FG-UDM-RX02) receiver.

Product Specifications

UDM-0102 Specifications	
Power Requirements:	24VDC @ .75A
Front Panel Components	
Ethernet (RJ-45) port:	Provides 10 BaseT network connectivity
Serial (RJ-12) port (labelled "10101"):	Enables an administrator to control the various functions to the UDM-0102 from a command line prompt and terminal connection. Requires a DB9-to-RJ12 adapter cable (FG-RS01) to connect to a PC.
LEDs:	The front LEDs are grouped by control type and are labeled according to their corresponding port (connector) numbers on the rear of the unit. <ul style="list-style-type: none"> • Power - device is receiving power • A - Source A is currently selected • B - Source B is currently selected • Status - changes from red to green when it receives a valid UDP command, and returns to red after 30 seconds if it has not received anything.
SELECT (A/B) Pushbutton:	Pushbutton switches between Source A / Source B.
PRESETS (1/2) Pushbuttons:	Two pushbuttons execute user-defined presets.
UDM (RJ-45) port:	Provides audio/video transport as well as control via Cat5, Cat5e or Cat6 to a UDM-RX02 Receiver.
Rear Panel Connectors:	
Source Inputs (A, B):	Two sets of input connectors for A/V source devices (labelled A and B): <ul style="list-style-type: none"> • VIDEO IN: HD-15 input connector (female) - supports VGA, Component, S-Video and Composite formats. • Analog Audio: Left (white) and Right (red) stereo RCA input connectors (female). • Digital Audio: SPDIF (female) input connector.
IRTX Ports:	Two 3.5mm stereo IR Transmitter output ports allow up to two IR-controlled devices (such as a DVD or VCR player) to be controlled via optional wired IR emitters.
IRRX Port:	3.5mm stereo input port, allows connecting an IR receiver to allow learning IR commands.

UDM-0102 Specifications (Cont.)	
Power Socket:	2.1mm barrel-style DC power socket (female)
Operating Environment:	<ul style="list-style-type: none"> • 35°F - 95°F (5°C - 35°C) • Max. relative humidity - 85% (non-condensing)
Dimensions (HWD):	1.61" x 8.63" x 3.66" (40.89 mm x 219.08 mm x 93.04 mm)
Weight:	1.60 lb. (730 g)
Certifications:	<ul style="list-style-type: none"> • CE • FCC part 15 Class A
Included Accessories:	Power Supply, 24VDC, 750 mA with cable (FG-UDM-PS)
Other AMX Equipment:	<ul style="list-style-type: none"> • HD15 to S-Video Cable (FG-UDM-SVID01) • HD15 to 3x RCA Breakout Cable (FG-HD15RCA3F) • RS232 DB9/RJ12 Connection Cable (FG-RS01) • UDM-RX02 Multi-Format Receiver (FG-UDM-RX02) • UDM-RC10 Multi-Format IR Engineering Remote Control (FG-UDM-RC10) • IR01 IR Emitter Module (FG-IR01) • IR03 External IR Receiver Module (FG-IR03)

Audio & Video Formats/Resolutions/Distance

Audio & Video Formats/Resolutions/Distance				
Class	Format	Name	Distance (m)	Distance (ft.)
Composite	720x480	NTSC	700	2300
	720x756	PAL	700	2300
Component	720x480	480p	700	2300
	720x756	576p	700	2300
	1280x720	720p	200	650
	1920x1080	1080i	150	500
VGA	1920x1080	1080p	120	400
	640x480	VGA	200	650
	800x600	SVGA	200	650
	1024x768	XGA	200	650
	1280x1024	SXGA	150	500
	1600x1200	UXGA	120	400

A/V Source Input Connectors

There are 2 sets of input connectors to the rear panel of the UDM-0102, labelled A and B (see FIG. 1) that allow the UDM-0102 to connect to A/V source devices.

Connecting a VGA Video Input

1. Connect one end of a VGA cable to the source device's VGA output port.
2. Attach the other end of the cable to the appropriate VIDEO IN connection (A or B) on the UDM. For example, connect to the Video In connection on Input A of the Hub.
3. Connect any audio to the analog (RCA) audio connectors or digital (SPDIF) connector.

Note: Ensure Input A is configured as a "VGA Input" and named appropriately within the "Inputs" section of the Configuration software. Also ensure the correct Audio Type (Analog L/R or S/PDIF) is selected for the relevant input.

Connecting a Composite Video Input

1. Connect the UDM-HD15RCA3F Breakout Cable (FG-HD15RCA3F, not included) to the source device's Composite output ports:
 - A1 = red RCA
 - A2 = green RCA
 - A3 = blue RCA
2. Attach the other end of the cable to the appropriate VIDEO IN connection (A or B) on the UDM.
3. Connect any audio to the analog (RCA) audio connectors or digital (SPDIF) connector.

Connecting a Component Video Input

1. Connect the UDM-HD15RCA3F Breakout Cable (FG-HD15RCA3F, not included) to the video source device's Component video output connectors (Red, Green and Blue).
2. Attach the other end of the cable to the appropriate VIDEO IN connection (A or B) on the UDM.
3. Connect any audio to the analog (RCA) audio connectors or digital (SPDIF) connector.

Connecting an S-Video Input

1. Connect the UDM-SVID01 HD-15 to SVideo cable (FG-UDM-SVID01, not included) to the video source's S-Video connection.
2. Attach the other end of the cable to the appropriate VIDEO IN connection (A or B) on the UDM.
3. Connect any audio to the analog (RCA) audio connectors or digital (SPDIF) connector.

Device Connectivity (IRTX Ports)

A maximum of 2 Devices such as DVD players or VCRs can be connected to the UDM Hub and controlled through the Browser software or via a remote control.

1. Connect an Endeleo IR Emitter Module (FG-IR01) to the relevant IRTX port at the rear of the Hub.
2. Run the other end of the IR Emitter to the device's IR sensor and attach the bud to the device's sensor by removing the cover of the reverse side of the bud.

IR commands for each device on the system have to be learned by the Hub in order to function properly. Refer to the Protocols and IR section of the *UDM-0102 Instruction Guide* on how to learn a device's IR commands.

IR Receiver (IRRX) Port

The IR RX port has two purposes:

- It is used for devices utilizing Passthrough Mode.
- Also used for learning and creating new IR protocols.

Refer to the *UDM-0102 Endeleo Multi-Format Distribution Mini-Hub Operation/Reference Guide* (available online at www.amx.com) for details.

Connecting a UDM-RX02 Receiver to the UDM Hub

1. Connect a standard Cat5/6 cable to the port marked *UDM* on the UDM Hub.
2. Connect the other end of the Cat5/6 cable to the "UDM Hub" port on the UDM-RX02.
3. When the power is switched on 2 LEDs will be visible at the Hub port – Amber (*phantom power enabled*) and Green (UDM-RX02 connected to Hub port).

Configuration Overview

Each UDM Hub can be configured for the correct network environment. It is also possible to configure each Hub for the correct date and time. Configuration options are available via the UDM Hub's built-in Browser Interface. Refer to the *UDM-0102 Endeleo Multi-Format Distribution Mini-Hub Operation/Reference Guide* for information on input configuration, user control, passthrough mode, video compensation, date/time configuration, creating scheduled events and scheduled presets

Connecting to the UDM-0102

1. With the TCP/IP address configured, connect the UDM-0102 to your network equipment (switch, hub, or serial port) - or if required use an Ethernet Cross-over cable to connect your PC directly.
2. Enter the IP address into the address field within a browser window. The default IP address of the UDM-0102 is **192.168.0.96**.
3. To connect to the UDM-0102, a password is required (FIG. 2).



FIG. 2 Endeleo Login screen

- The username should be left *blank*.
- The password is **admin**.
- The password is *case sensitive*.

4. On initial connection, the **Status** page is displayed.

Network Configuration

Hubs can be configured for the network environment using the *Setup* page.

Note: The UDM-0102 does not support DHCP. Always configure a static IP Address.

1. Specify the following network options for the Hub:
 - a. Hub IP Address, Subnet Mask and Default Gateway;
 - b. UDP Port (default = **2008**)
 - c. Hub name (maximum of 30 characters).
2. Click on **Update** to save the new settings to the Hub (FIG. 3).

Note: All changes are immediate - once the IP address of the hub has been changed redirect the web browser to the changed address.

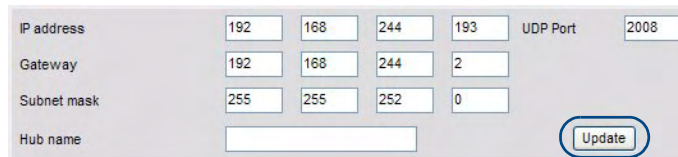

FIG. 3 Network Settings

Restoring Hub Configuration and Connections on Power Up

To ensure the configuration settings for the Hub are retained each time the hub boots, ensure the *Restore configuration on power up* and *Restore connections on power up* options (at the bottom of the *Setup* page) have been enabled (FIG. 4).

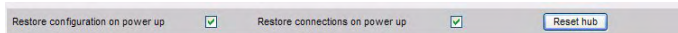

FIG. 4 Restoring configuration on power up

Note: Failure to select the *Restore Configuration and Connection* options will mean the Hub configuration and connections will need to be re-configured if the Hub is reset.

Hub Reset

To reset the Hub, Click the **Reset Hub** button (FIG. 4).

Note: A power down of the Hub is required to complete the reset procedure.

Input Configuration

The options on the *Inputs* page allow you to specify the video types and audio sources being presented to each input port and where appropriate renaming these.

1. Select the **Inputs** link at the top of the *Status* page to invoke the *Input Configuration* page (FIG. 5).

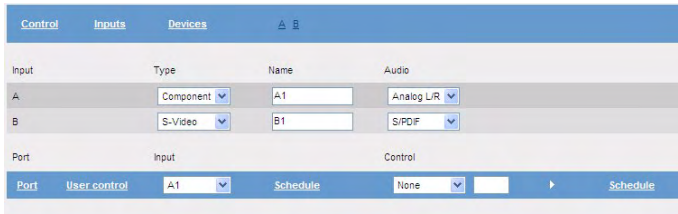

FIG. 5 Input Configuration page

2. Use the *Type* drop-down menus to select the appropriate Input **Type** for each input).
 - For VGA, Component, S-Video, and Composite inputs, only one connection is possible per input port.
 - If the Input Type is *Composite*, then the screen will refresh and enable the administrator to name each of the 3 available composite sources separately.
3. **Name** the input *Type(s)* appropriately.

Configuring Audio Types For Inputs

Audio types (Analog L/R or S/PDIF) can be configured for each Input. To configure audio for individual Inputs;

1. Select the **Inputs** option from the available options at the top of the *Status* page.
2. Select the appropriate **Audio** type *Analog L/R* or *S/PDIF*.
 - If "Composite" is selected as the Input type, only one audio source will be available.
 - Ensure audio has been connected from the Input to the rear of the hub. Ensure the connections are sound and fixed correctly.

Manually Switching Sources

The UDM-0102 supports 2 AV input sources that can be switched manually. To switch the inputs at the device, press the **SELECT** pushbutton on the front of the device.

Manually Executing Presets

The UDM-0102 supports a total of 2 presets.

1. Select the AV input source (1 or 2), via the **SELECT** pushbutton.
2. Select either **PRESET 1** or **PRESET 2** to execute.

Powering The UDM-0102 On/Off

• **Powering on the Hub:** Insert the barrel connector of the power supply into the power connector on the UDM.

• **Powering off the Hub:** Remove the barrel connector of the power supply from the power connector on the UDM.

Additional Documentation

Refer to the *UDM-0102 and UDM-RX02 Multi-Format Distribution Hub and Receiver Operation/Reference Guide* (available online at www.amx.com) for detailed information on configuring the Hub, UDM receivers and source devices.