

PRO-FORM[®] 890E

PERFORMANCE CYCLE

Model No. PFEVEX34181

Serial No. _____

Write the serial number in the space above for future reference.

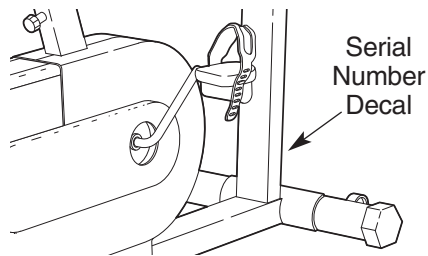

Class H C Fitness Product

QUESTIONS?

As a manufacturer, we are committed to providing complete customer satisfaction. If you have questions, or if there are missing or damaged parts, we will guarantee complete satisfaction through our Customer Service Department.

Please CALL:
0345-089009

Or WRITE:
ICON Fitness Lifestyle Ltd.
Greenwich House
223 North Street
Sheepscar
West Yorkshire
Leeds LS7 2AA

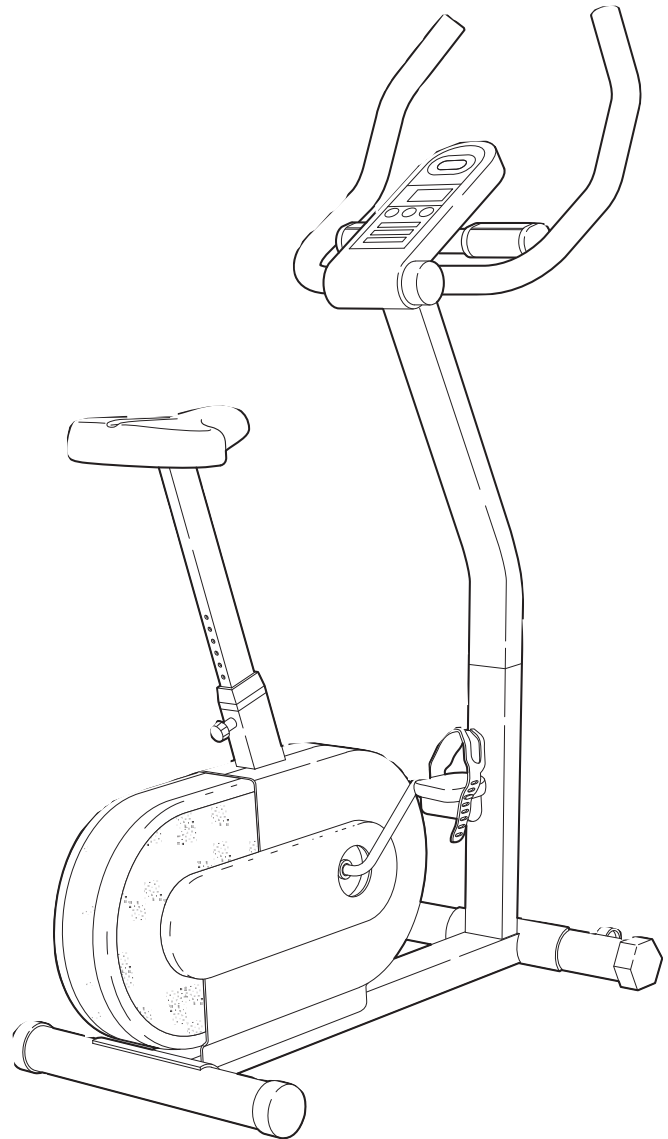

CAUTION

Read all precautions and instructions in this manual before using this equipment. Keep this manual for future reference.

USER'S MANUAL

PRO·FORM[®] 890E

P E R F O R M A N C E C Y C L E

TABLE OF CONTENTS

IMPORTANT PRECAUTIONS3
BEFORE YOU BEGIN4
ASSEMBLY5
HOW TO USE THE PROFORM [®] 890E8
HOW TO USE THE HAND PULSE MONITOR10
MAINTENANCE AND TROUBLE-SHOOTING11
CONDITIONING GUIDELINES13
PART LIST14
EXPLODED DRAWING15
HOW TO ORDER REPLACEMENT PARTSBack Cover

EXPLODED DRAWING—Model No. PFEVEX34181

R1298A

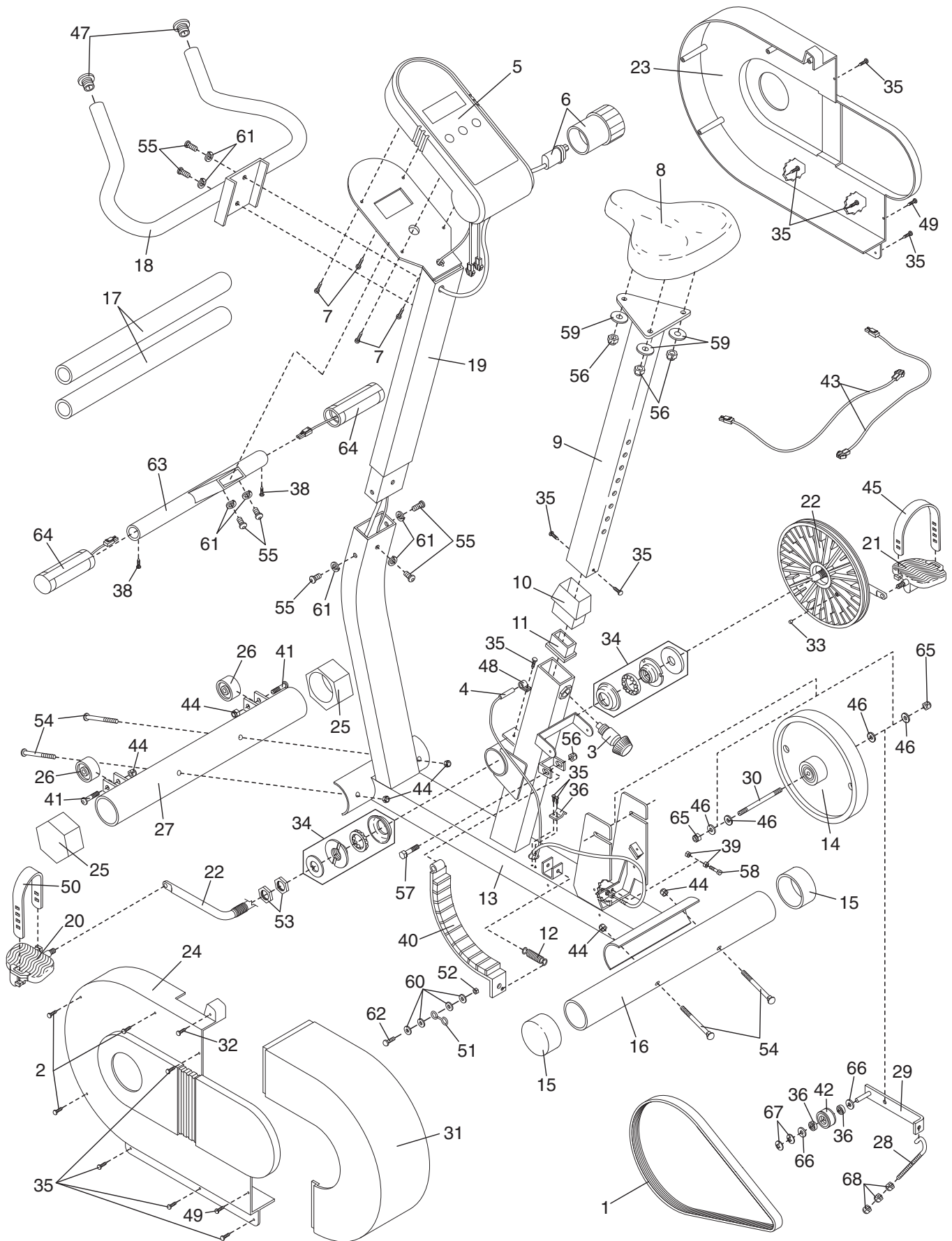

PART LIST—Model No. PFEVEX34181

R1298A

Key No.	Qty.	Description	Key No.	Qty.	Description
1	1	49" Drive Belt	35	13	M4 x 16mm Washer Head Screw
2	3	M4 x 38mm Screw	36	2	608 Bearing
3	1	Seat Knob w/Pin	37	1	Cable Clamp
4	1	Reed Switch w/Wire	38	2	Pulse Grip Screw
5	1	Console	39	2	M6 Nut
6	1	Resistance Knob w/Cable	40	1	"C" Magnet
7	4	M4 x 16mm Screw	41	2	M10 x 45mm Button Head Bolt
8	1	Seat	42	2	Idler Pulley
9	1	Seat Post	43	2	Pulse Wire
10	1	Seat Collar	44	8	M10 Nylon Locknut
11	1	Seat Tube Spacer	45	1	Right Pedal Strap
12	1	Spring	46	3	M10 Washer
13	1	Frame	47	2	Handlebar Endcap
14	1	Flywheel	48	1	Reed Switch Clip
15	2	Round Endcap	49	2	M6 x 16mm Self-tapping Screw
16	1	Rear Stabiliser	50	1	Left Pedal Strap
17	2	Foam Grip	51	1	Resistance Hook
18	1	Handlebar	52	1	Clamp Nut
19	1	Handlebar Post	53	2	Hex Jam Nut
20	1	Left Pedal w/Strap	54	4	M10 x 75mm Carriage Bolt
21	1	Right Pedal w/Strap	55	7	M10 x 22mm Button Head Bolt
22	1	Crank/Pulley	56	5	M8 Nylon Locknut
23	1	Right Side Shield	57	1	M8 x 43mm Hex Head Bolt
24	1	Left Side Shield	58	1	M6 x 64mm Hex Head Bolt
25	2	Adjustable Endcap	59	3	M8 Lock Washer
26	2	Wheel	60	4	#8 Flat Washer
27	1	Front Stabiliser	61	7	M10 Lock Washer
28	1	Idler Wheel Bolt	62	1	Clamp Bolt
29	1	Idler Wheel Bracket	63	1	Pulse Handlebar
30	1	Flywheel Axle	64	2	Pulse Grip
31	1	Flywheel Cover	65	2	M8 Axle Nut
32	1	M4 x 25mm Screw	#	1	User's Manual
33	1	Magnet	#	1	Caution Decal Sheet
34	1	Crank Bearing Assembly	#	1	Warning Decal Sheet

Note: "#" indicates a non-illustrated part. Specifications are subject to change without notice. See the back cover of this manual for information about ordering replacement parts.

IMPORTANT PRECAUTIONS

WARNING: To reduce the risk of serious injury, read the following important precautions before using the PROFORM® 890E exercise cycle.

1. Read all instructions in this manual before using the exercise cycle. Use the exercise cycle only as described.
2. It is the responsibility of the owner to ensure that all users of the exercise cycle are adequately informed of all precautions.
3. Use the exercise cycle indoors, away from moisture and dust. Place the exercise cycle on a level surface, with a mat beneath it to protect the floor or carpet from damage.
4. Inspect and tighten all parts regularly. Replace any worn parts immediately.
5. Keep children under the age of 12 and pets away from the exercise cycle at all times.
6. The exercise cycle should not be used by persons weighing more than 250 pounds.
7. Wear appropriate clothing when exercising; do not wear loose clothing that could become caught on the exercise cycle. Always wear athletic shoes for foot protection.
8. The pulse monitor is not a medical device. Various factors, including the user's movement, may affect the accuracy of heart rate readings. The pulse monitor is intended only as an exercise aid in determining heart rate trends in general.
9. Always keep your back straight when using the exercise cycle. Do not arch your back.
10. If you feel pain or dizziness at any time whilst exercising, stop immediately and begin cooling down.
11. The exercise cycle is intended for in-home use only. Do not use the exercise cycle in a commercial, rental or institutional setting.
12. The decal shown below has been placed on the exercise cycle. If the decal is missing, or if it is not legible, please call our Customer Service Department at 0345-089009 to order a free replacement decal. Apply the decal in the location shown.

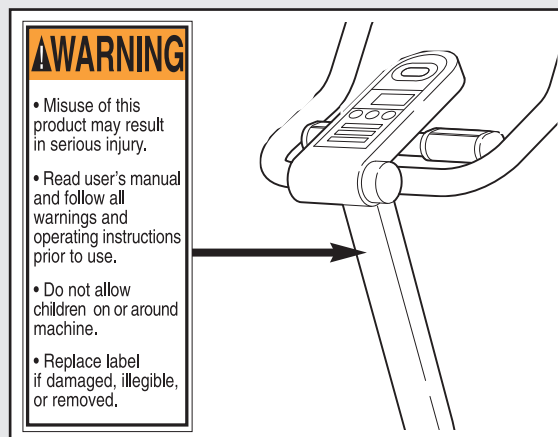

WARNING: Before beginning this or any exercise program, consult your physician. This is especially important for persons over the age of 35 or persons with pre-existing health problems. Read all instructions before using. ICON assumes no responsibility for personal injury or property damage sustained by or through the use of this product.

BEFORE YOU BEGIN

Thank you for selecting the innovative PROFORM® 890E exercise cycle. Cycling is one of the most popular and effective exercises for improving cardiovascular fitness and toning the body. The PROFORM® 890E blends advanced engineering with contemporary styling to let you enjoy the benefits of this exercise in the convenience and privacy of your home.

Please read this manual carefully before you use the PROFORM® 890E. If you have additional ques-

tions, please call our Customer Service Department at **0345-089009**. To help us assist you, please mention the product model number and serial number when calling. The model number is PFEVEX34181. The serial number can be found on a decal attached to the PROFORM® 890E (see the front cover of this manual for the location of the decal).

Before reading further, please familiarise yourself with the parts that are labelled in the drawing below.

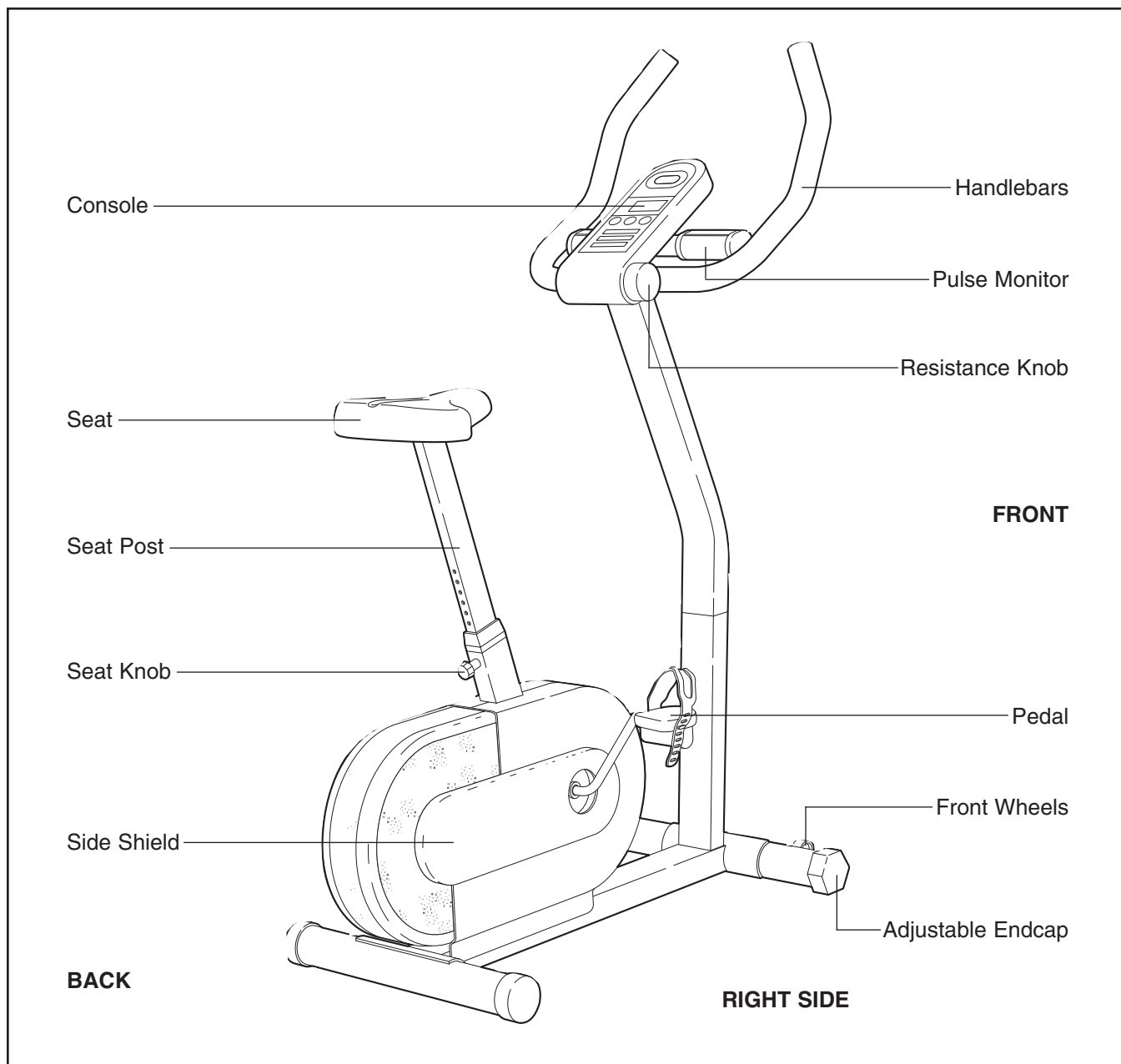

CONDITIONING GUIDELINES

The following guidelines will help you to plan your exercise program. Remember that proper nutrition and adequate rest are essential for successful results.

WARNING: Before beginning any exercise program, consult your physician. This is especially important for persons over the age of 35 or persons with pre-existing health problems.

EXERCISE INTENSITY

Whether your goal is to burn fat or to strengthen your cardiovascular system, the key to achieving the desired results is to exercise with the proper intensity. The proper intensity level can be found by using your heart rate as a guide. The chart below shows recommended heart rates for fat burning, maximum fat burning, and cardiovascular (aerobic) exercise.

20	30	40	50	60	70	80	AGE
165							
145	155						
125	138	145	140				
	120	130	125	130			
		115	110	118	125		
				105	110	115	AEROBIC
					95	105	MAX. FAT
						90	FAT BURN

b.p.m.

To find the proper heart rate for you, first find your age at the top of the chart (ages are rounded off to the nearest ten years). Next, find the three numbers below your age. The three numbers are your “training zone.” The lowest number is the recommended heart rate for fat burning; the middle number is the heart rate for maximum fat burning; and the highest number is the heart rate for aerobic exercise.

Burning Fat

To burn fat effectively, you must exercise at a relatively low intensity level for a sustained period of time. During the first few minutes of exercise, your body uses easily accessible *carbohydrate* calories for energy. Only after the first few minutes of exercise does your body begin to use stored *fat* calories for energy. If your goal is to burn fat, adjust the intensity of your exercise until your heart rate is near the lowest number in your training zone as you exercise.

For maximum fat burning, adjust the intensity of your exercise until your heart rate is near the middle number in your training zone as you exercise.

Aerobic Exercise

If your goal is to strengthen your cardiovascular system, your exercise must be “aerobic.” Aerobic exercise is activity that requires large amounts of oxygen for prolonged periods of time. This increases the demand on the heart to pump blood to the muscles, and on the lungs to oxygenate the blood. For aerobic exercise, adjust the intensity of your exercise until your heart rate is near the highest number in your training zone.

WORKOUT GUIDELINES

Each workout should include three important parts: a warm-up, training zone exercise, and a cool-down.

Warming up—Begin each workout with 5 to 10 minutes of stretching and light exercise. A proper warm-up increases your body temperature, heart rate and circulation in preparation for exercise.

Training zone exercise—After warming up, increase the intensity of your exercise until your heart rate is in your training zone for 20 to 30 minutes. (During the first few weeks of your exercise program, do not keep your heart rate in your training zone for longer than 20 minutes.)

Cooling down—Finish each workout with 5 to 10 minutes of stretching. This will increase your flexibility and will help to prevent post-exercise problems.

EXERCISE FREQUENCY

To maintain or improve your condition, plan three workouts each week, with at least one day of rest between workouts. After a few months of regular exercise, you may complete up to five workouts each week if desired. Remember, the key to success is make exercise a regular and enjoyable part of your everyday life.

CAUTION: Be sure to progress at your own pace and avoid overdoing it. Incorrect or excessive training may result in injury to your health.

HOW TO ADJUST THE REED SWITCH

If the console does not display correct feedback, the reed switch should be adjusted. To adjust the reed switch, the Left Side Shield (24) and the Flywheel Cover (31) must be removed. Using an adjustable wrench, turn the Left Pedal (20) clockwise and remove it. Next, remove the indicated Screws (2, 32, 35, 49). Turn the left arm of the Crank (22) to the position shown and slide off the Left Side Shield and the Flywheel Cover.

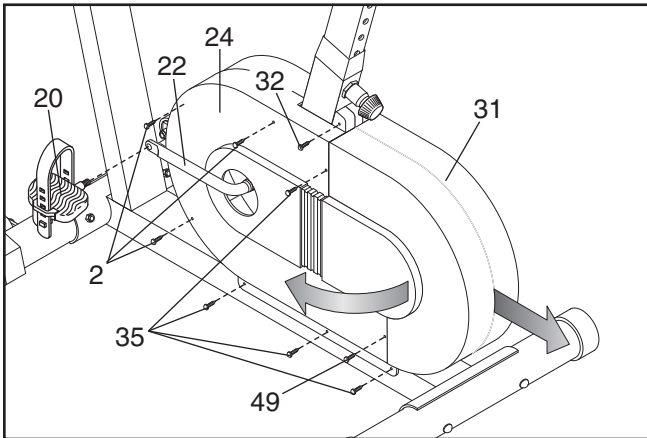

Next, locate the Reed Switch (4). Turn the arms of the Crank (22) until the Magnet (33) is aligned with the Reed Switch. Loosen but do not remove the indicated Screw (35). Slide the Reed Switch slightly closer to or away from the Magnet. Retighten the Screw. Turn the Crank for a moment. Repeat until the console displays correct feedback. When the Reed Switch is correctly adjusted, reattach the left side shield, flywheel cover and left pedal.

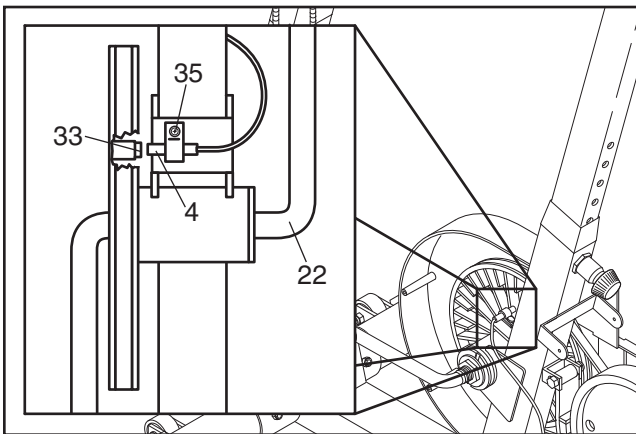

HOW TO ADJUST THE DRIVE BELT

The exercise cycle features a Drive Belt (1) that must be kept properly adjusted. If the Drive Belt slips as you pedal, it should be adjusted. To do this, the left side shield and the flywheel cover must be removed. Refer to the instructions at the left and remove these parts.

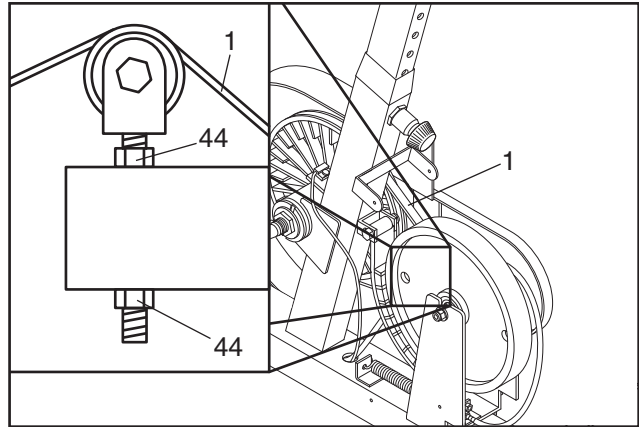

Locate the Drive Belt (1). To tighten the Drive Belt, loosen the bottom M10 Nylon Locknut (44) and then tighten the upper M10 Nylon Locknut (44) slightly; **be careful not to overtighten the Drive Belt**. When the Drive Belt is properly adjusted, tighten the lower M10 Nylon Locknut (44). Then, reattach the left side shield, the flywheel cover, and the left pedal.

ASSEMBLY

Place all parts of the exercise cycle in a cleared area and remove the packing materials. Do not dispose of the packing materials until assembly is completed.

Assembly requires the included allen wrench , a phillips screwdriver  and two adjustable spanners .

1. Hold the Handlebar Post (19) near the Frame (13) as shown. Feed the Resistance Cable (6) and the Reed Switch Wire (4) into the Frame, and then slide the Handlebar Post into the Frame. **Be careful not to pinch the Resistance Cable or the Reed Switch Wire.** Attach the Handlebar Post with three M10 x 22mm Button Head Bolts (55) and three M10 Lock Washers (61).

The Console (5) requires one 9V battery (not included). An alkaline battery is recommended. Refer to the inset drawing. Locate the battery door on the back of the Console. Slide the battery door to the left and open it as shown. Press a battery into the battery clip and insert the battery into the Console. Close the battery door and slide it to the right.

2. Make sure that there are Adjustable Endcaps (25) on the ends of the Front Stabiliser (27).

Attach the Front Stabiliser (27) to the saddle on the front of the Frame (13) with two M10 x 75mm Carriage Bolts (54) and two M10 Nylon Locknuts (44).

3. Make sure that there are Round Endcaps (15) on the ends of the Rear Stabiliser (16).

Hold the Rear Stabiliser (16) against the saddle on the rear of the Frame (13), with the square holes facing away from the saddle. Attach the Rear Stabiliser with two M10 x 75mm Carriage Bolts (54) and two M10 Nylon Locknuts (44).

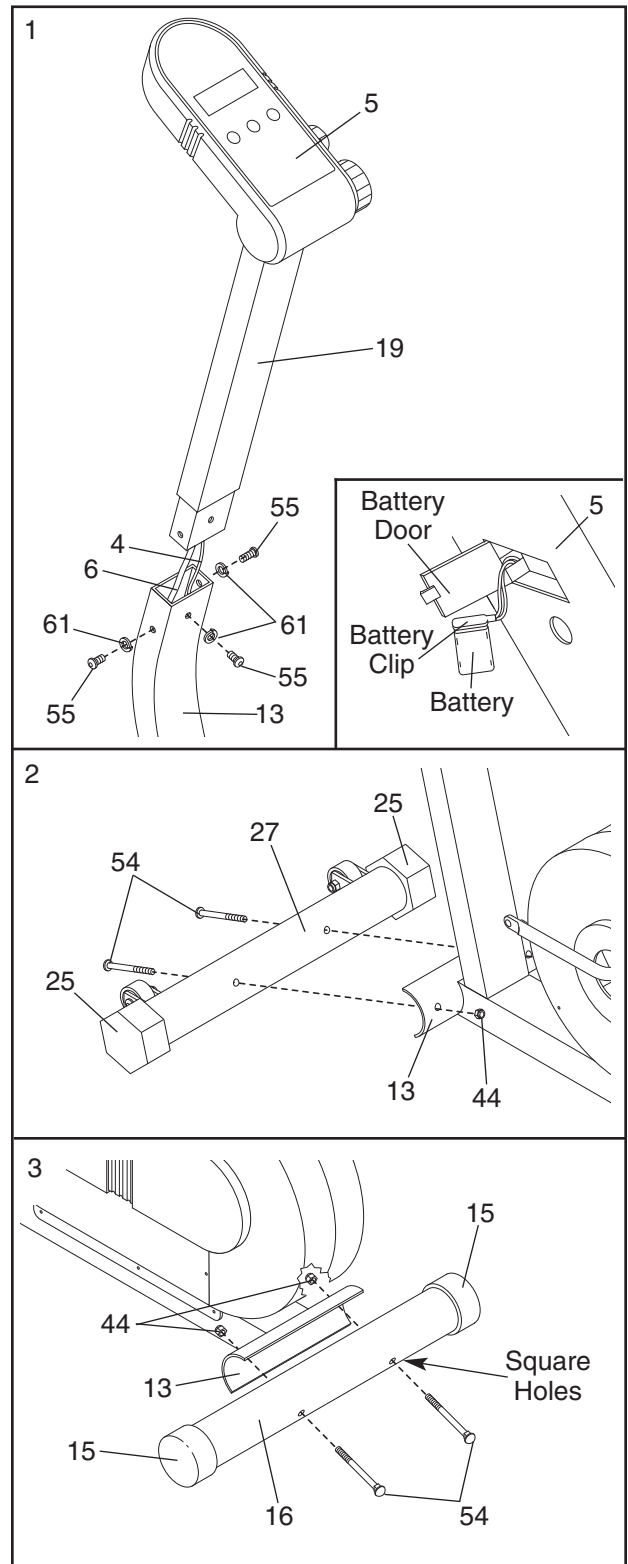

- Turn the Seat Knob (3) counterclockwise several turns to loosen it. Next, pull back the Seat Knob and insert the Seat Post (9) into the Frame (13). Slide the Seat Post to the desired height and release the Seat Knob. **Move the Seat Post up or down slightly until it locks into place.** Turn the Seat Knob clockwise to tighten it.

Press the Seat Collar (10) into the Frame (13).

Next, attach the Seat (8) to the Seat Post (9) with the three M8 Nylon Locknuts (56) and M8 Lock Washers (59). Note: The M8 Nylon Locknuts and M8 Lock Washers may be pre-attached to the bottom of the Seat.

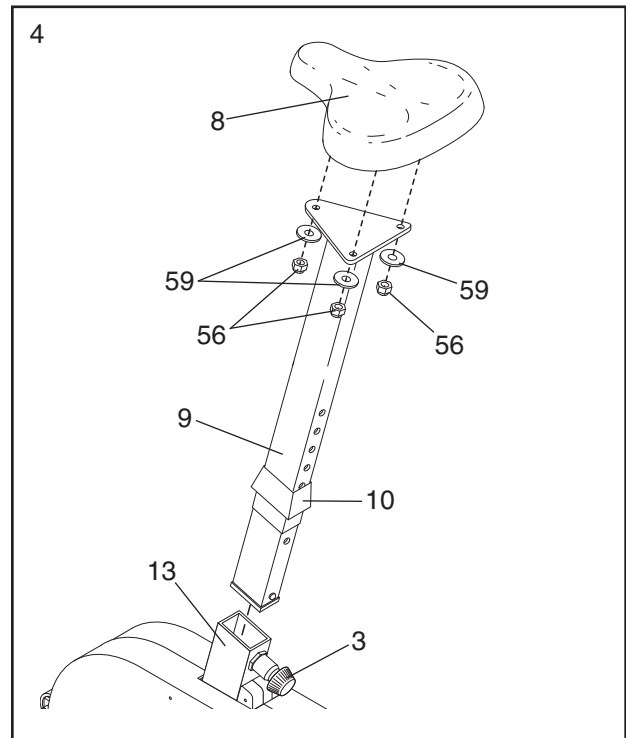

- Identify the Left Pedal (20); there is an "L" on the Left Pedal for identification. Using an adjustable wrench, tighten the Left Pedal *counterclockwise* into the left arm of the Crank (22).

Tighten the Right Pedal (not shown) *clockwise* into the right arm of the Crank (22).

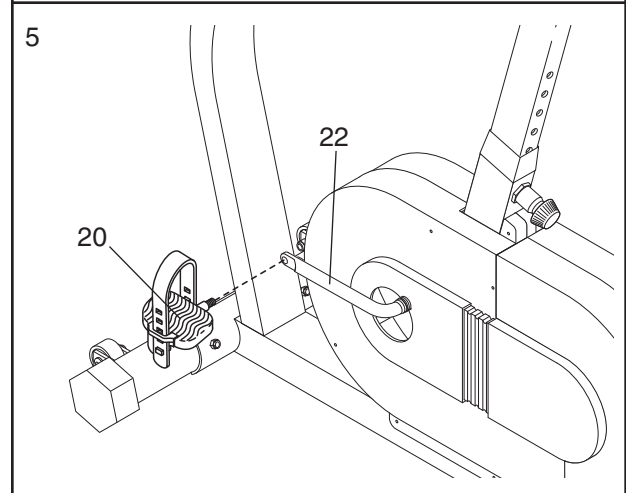

- Hold the Pulse Handlebar (63) near the Handlebar Post (19) as shown. Connect the two Pulse Wires (43) to the two console wires, making sure that the wires with tags are connected to each other (see the inset drawing). Carefully push the wires down into the Pulse Handlebar.

Attach the Pulse Handlebar (63) to the Handlebar Post (19) with two M10 x 22mm Button Head Bolts (55) and two M10 Lock Washers (61). **Be careful to avoid pinching the wires.**

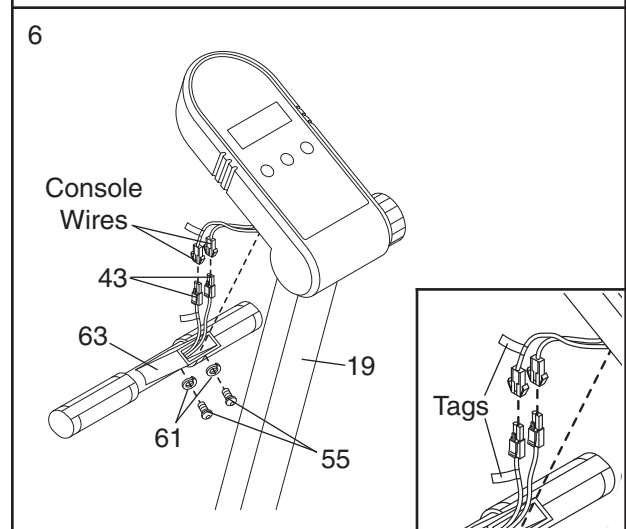

- If an “L” or an “H” appears in the display, the pulse monitor is receiving too little or too much pulse information. Let go of the metal contacts and then place your hands on the contacts again. Your palms must be resting on the inner contacts and your fingers must be touching the outer contacts.
- For the most accurate heart rate reading, wait for about 15 seconds.
- For optimal performance of the pulse monitor, keep the metal contacts clean. The contacts can be cleaned with a soft cloth—do not use alcohol, abrasives, or chemicals.

MAINTENANCE AND TROUBLE-SHOOTING

Inspect and tighten all parts of the exercise cycle regularly. Replace any worn parts immediately.

The exercise cycle can be cleaned with a soft, damp cloth. Avoid spilling liquid on the console or the pulse monitor. Keep the console out of direct sunlight or the display may be damaged. Remove the battery when storing the exercise cycle.

BATTERY REPLACEMENT

If the console does not function properly, replace the battery (see assembly step 1 on page 5).

HOW TO LEVEL THE EXERCISE CYCLE

If the exercise cycle does not sit flat on the floor, try turning one or both of the Adjustable Endcaps (25) at the front of the exercise cycle until the exercise cycle is level.

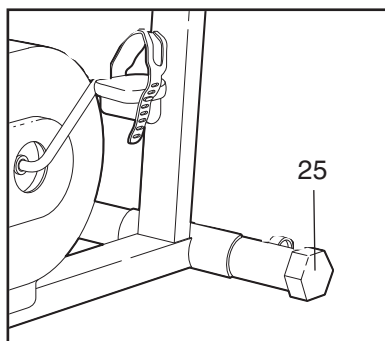

HOW TO TIGHTEN THE CRANK

If the arms of the Crank (22) become loose, they should be tightened in order to prevent excessive wear. Loosen the two Hex Jam Nuts (53) on the left arm of the Crank. Place the end of a standard

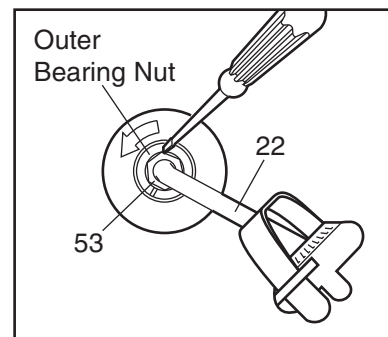

screwdriver in one of the slots in the outer bearing nut. Tap the screwdriver with a hammer to turn the outer bearing nut counterclockwise until the arms are no longer loose. **Do not overtighten the outer bearing nut.** When the outer bearing nut is properly tightened, retighten the Hex Jam Nut.

The scan mode—
Repeatedly press the mode button until an arrow appears under the scan symbol. When the scan mode is selected, the console will display the speed, time, distance, lap and calorie modes, for 5 seconds each, in a repeating cycle.

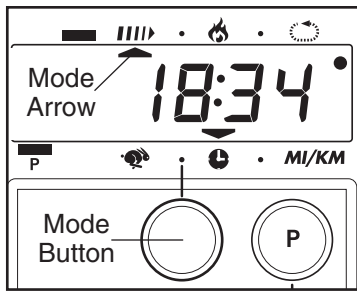

The speed, time, distance, lap, or calorie mode—
Repeatedly press the mode button until an arrow appears below or above the desired mode symbol. Make sure that there is not an arrow under the scan symbol.

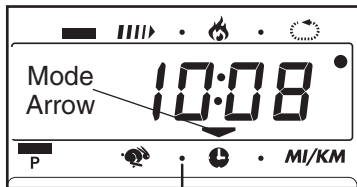

To reset the display, press the on/reset button.

5 Turn off the power

To turn off the power, simply wait for about six minutes. If the pedals are not turned and the console buttons are not pressed for six minutes, the power will turn off automatically.

HOW TO SELECT KILOMETRES OR MILES

The console can display distance and speed in either kilometres or miles. If a “KPH” appears in the display, distance and speed will be shown in kilometres; if a “KPH” does not appear, distance and speed will be shown in miles.

To change the unit of measurement, first remove the four screws attaching the console (see drawing 1). Lift the console a few inches and turn it over, being careful not to pull on the wires. Next, look into the hole below the battery door, and locate the small switch (see drawing 2). (Note: It may be necessary to look into the hole and to the left side to find the small switch.) Slide the switch up or down to change the unit of measurement. Reattach the console with the four screws.

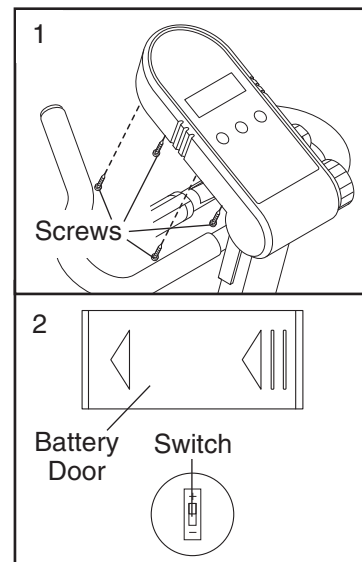

HOW TO USE THE PULSE MONITOR

The built-in pulse monitor allows you to measure your heart rate at any time during your workouts. You can measure your heart rate before you begin exercising, while you exercise, and again when you finish.

To use the pulse monitor, first make sure that the power is on. Next, stop exercising, rest both feet on the floor, and place your hands on the metal contacts of the pulse monitor. **Your palms must be**

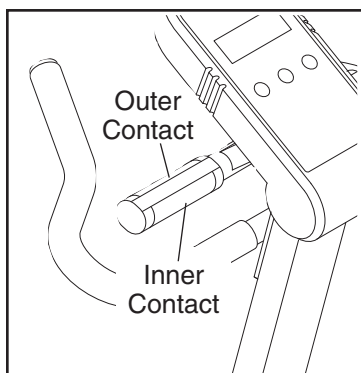

resting on the inner contacts and your fingers must be touching the outer contacts. Avoid moving your hands. When your pulse is detected, a heart-shaped indicator in the display will flash. After a moment, three dashes will appear and your heart rate will be shown. For the most accurate reading, continue to hold the contacts for about 15 seconds.

PULSE MONITOR TROUBLE-SHOOTING

- Do not squeeze the metal contacts too tightly or move your hands while using the pulse monitor. Doing so may interfere with heart rate readings. If the pulse monitor is not used correctly, the heart-shaped indicator in the display will flash repeatedly but your heart rate will not be shown.

7. Attach the Handlebar (18) to the Handlebar Post (19) with two M10 x 22mm Button Head Bolts (55) and two M10 Lock Washers (61).

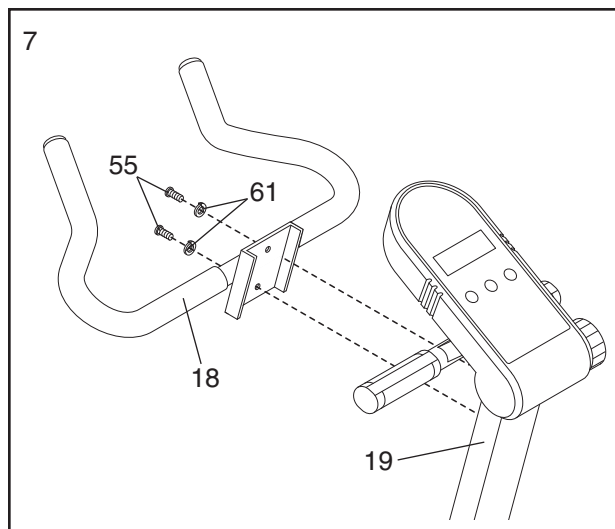

8. **Make sure that all parts are tightened before you use the exercise cycle.** To protect the floor from damage, place a mat beneath the exercise cycle.

HOW TO USE THE PROFORM® 890E

HOW TO ADJUST THE SEAT

For effective exercise, the Seat (8) should be at the proper height; as you pedal, there should be a slight bend in your knees when the pedals are at the lowest position. To adjust the Seat, first turn the Seat Knob (3) counterclockwise several turns to loosen it. Next, pull back the Seat Knob, slide the Seat Post (9) to the desired height, and release the Seat Knob. **Move the Seat Post up or down slightly until it locks into place.** Turn the Seat Knob clockwise to tighten it.

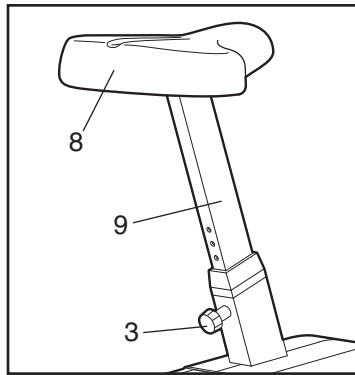

HOW TO ADJUST THE PEDALING RESISTANCE

To vary the intensity of your exercise, the resistance of the pedals can be changed with the Resistance Knob (6). The arrows to the left of the Knob show which direction the Knob must be turned to increase or decrease the resistance. As the resistance is changed, the green and red indicator between the arrows will also change.

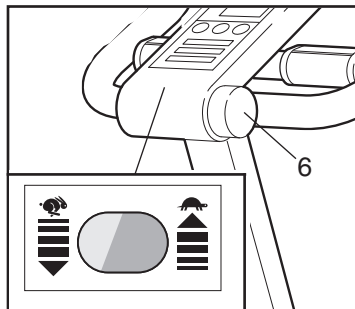

HOW TO ADJUST THE PEDAL STRAPS



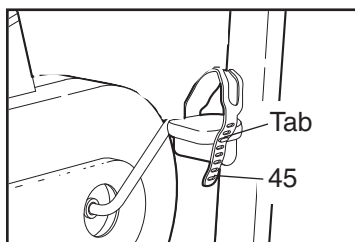



To adjust each Pedal Strap (45), pull the Pedal Strap off the tab on the pedal. Align the desired hole in the Pedal Strap with the tab and press the Pedal Strap back onto the tab.

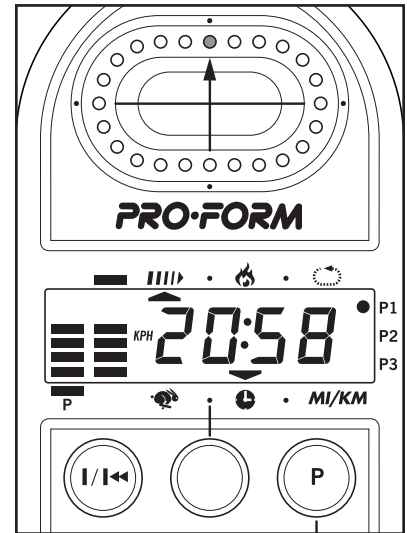

DESCRIPTION OF THE CONSOLE

The innovative console offers a manual mode and three pacer programs. The pacer programs are designed to help you achieve specific exercise goals by pacing your exercise. You can choose from a stamina-building Interval program, an Aerobic program, and a special Fat Burn program. As you exercise, seven monitor modes will provide continuous exercise feedback. The monitor modes are described below:



-  Speed—This mode shows your pedaling pace, in kilometres or miles per hour (see HOW TO SELECT KILOMETRES OR MILES on page 10).
-  Time—If you select the manual mode, this mode will show the elapsed time. If you select one of the three pacer programs, this mode will count down the time remaining in the program.
-  **MI/KM** Distance—This mode shows the distance you have pedaled, in kilometres or miles.
-  Lap—This mode shows the number of laps you have completed. One lap equals 0.25 kilometres or miles.
-  Calorie—This mode shows the approximate number of calories you have burned.
-  Scan—This mode displays the above five modes, for 5 seconds each, in a repeating cycle.
-  Pulse—This mode shows your heart rate when the pulse monitor is used. (See HOW TO USE THE PULSE MONITOR on page 10.)

HOW THE PACER PROGRAMS OPERATE

When you use a pacer program, two columns of bars will appear in the display. The left column represents a target pace, and the right column shows your actual pedaling pace. The target pace will change periodically during the program; as the target pace changes, simply adjust your pedaling pace to keep both columns at the same height. **Important: The target pace is a goal pace. Your actual pace may be slower than the target pace, especially during the first few months of your exercise program. Be sure to exercise at a pace that is comfortable for you.**

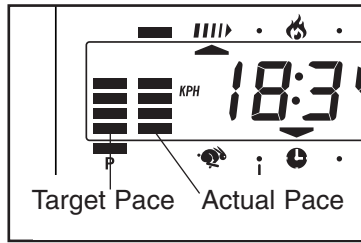

The three graphs on the console show how the target pace will change during the programs. Each graph is divided into ten columns of bars. Each column represents a two-minute period, and each bar represents a target pace of 5 mph (8 kph). In graph P1, for example, there is one bar in the farthest left column. This shows that during the first two minutes of program P1, the target pace will be 5 mph (8 kph). In the second column there are five bars. This shows that during the second two-minute period, the target pace will be 25 mph (40 kph). Each program will last for twenty minutes.

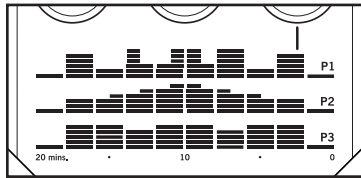

STEP-BY-STEP CONSOLE OPERATION

Before the console can be operated, a battery must be installed. (See assembly step 1 on page 5.) Follow the steps below to operate the console.

1 Turn on the power

To turn on the power, press the on/reset button or simply begin pedaling. The entire display will appear for two seconds; the console will then be ready for use. Note: If a battery was just installed, the power will already be on.

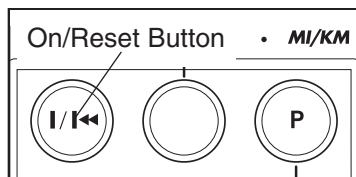

2 Select one of the three pacer programs or the manual mode

To select one of the pacer programs, repeatedly press the program button. The program indicator will show which program you have selected.

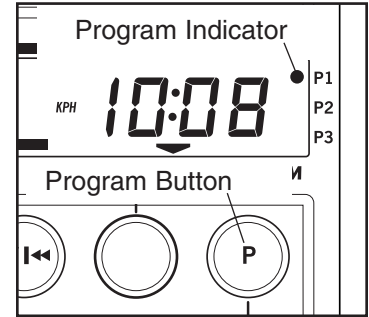

To select the manual mode, press the program button until the program indicator disappears. The programs will be selected in the following order: program 1 (Interval), program 2 (Aerobic), program 3 (Fat Burn), manual mode.

3 Begin your workout

If you selected the manual mode, go to step 4. If you selected one of the pacer programs, two columns of bars will appear in the display. The left column will show one bar, showing that the target pace is 5 mph (8 kph). The right column will show your actual pedaling pace. Adjust your pedaling pace until only one bar appears in the right column. Each time the target pace changes during the program, adjust your pedaling pace to keep both columns at the same height.

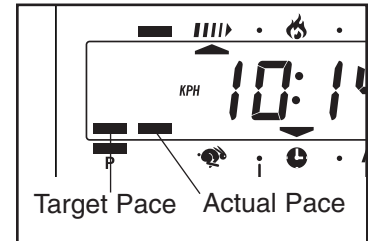

4 Follow your progress with the LED track and the seven monitor modes

The LED track—The LED track represents a distance of 0.25 kilometres or miles. As you pedal, the indicators around the track will light one at a time until you have completed one lap. A new lap will then begin.

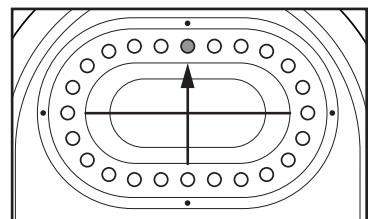

HOW TO ORDER REPLACEMENT PARTS

If you encounter any difficulties with this product, or if you need to order replacement parts, write or call the ICON Fitness Lifestyle Ltd. office at:

ICON Fitness Lifestyle Ltd.
Greenwich House
223 North Street
Sheepscar
West Yorkshire
Leeds LS7 2AA

Tel: Country Code: 0345-089009
Fax: 0113-2411120

Please provide the following information when calling or writing:

- The MODEL NUMBER of the product (PFEVEX34181).
- The NAME of the product (PROFORM® 890E).
- The SERIAL NUMBER of the product (see the front cover of this manual).
- The KEY NUMBER and DESCRIPTION of the part(s) (see the PART LIST on page 14 of this manual).