



# DIE CAST BLENDER

Model Number: 169106  
UPC: 681131691062

**Customer Assistance**

1 877 207 0923 (US)  
1 877 556 0973 (Canada)



**Thank you for purchasing a GE small appliance.**

In keeping with the GE ecomagination initiative, please consider the option to recycle the packaging material and donate the appliance you are no longer using.

To read about GE's ecomagination commitment, visit  
<http://ge.ecomagination.com>

# IMPORTANT SAFEGUARDS

When using electrical appliances, basic safety precautions should always be followed including the following:

- Read all instructions.
- To protect against risk of electrical shock do not immerse power cord or blender base in water or other liquid.
- Close supervision is necessary when any appliance is used by or near children.
- Unplug from outlet when not in use, before putting on or taking off parts, and before cleaning.
- Avoid contacting moving parts.
- Do not operate any appliance with a damaged cord or plug or after the appliance malfunctions, or is dropped or damaged in any manner. Call our toll-free customer service number for information on examination, repair, or adjustment.
- The use of attachments, including canning jars, not recommended by the manufacturer may cause a risk of injury to persons.
- Do not use outdoors.
- Do not let cord hang over edge of table or counter or touch hot surfaces.
- Keep hands and utensils out of container while blending to reduce the risk of severe injury to persons or damage to the blender. A scraper may be used but must be used only when the blender is not running.
- Blades are sharp. Handle carefully.
- To reduce the risk of injury, never place cutter-assembly blades on base without jar properly attached.
- Always operate blender with cover in place.
- When blending hot liquids, remove center piece of two-piece cover.
- Do not place on or near hot gas or electric burner or in a heated oven
- To disconnect, turn the control to off then remove plug from wall outlet
- Do not use appliance for other than intended use.

# SAVE THESE INSTRUCTIONS!

This appliance is for **HOUSEHOLD USE ONLY**. It may be plugged into an AC electrical outlet (ordinary household current). Do not use any other electrical outlet.

**DO NOT OPERATE APPLIANCE IF THE LINE CORD SHOWS ANY DAMAGE, OR IF APPLIANCE WORKS INTERMITTENTLY OR STOPS WORKING ENTIRELY.**

A short power-supply cord (or detachable power-supply cord) is to be provided to reduce the risk resulting from becoming entangled in or tripping over a longer cord. Longer detachable power-supply cords or extension cords are available and may be used if care is exercised in their use. If a longer detachable power-supply cord or extension cord is used,

- 1) The marked electrical rating of the cord set or extension cord should be at least as great as the electrical rating of the appliance, and
- 2) The cord should be arranged so that it will not drape over the countertop or tabletop where it can be pulled on by children or tripped over unintentionally.

If the power-supply cord is a grounding-type-3-wire cord with a grounding prong on the plug, the extension cord should also be a grounding-type-3-wire cord.

### GROUNDING INSTRUCTIONS

This appliance must be grounded while in use to protect the operator from electrical shock. The appliance is equipped with a 3-conductor cord and a 3-prong grounding-type plug to fit the proper grounding-type receptacle. The appliance has a plug that looks like Figure A. An adaptor, as shown in Figure B, should be used for connecting a 3-prong grounding plug to a 2-ground receptacle. The grounding tab, which extends from the adaptor, must be connected to a permanent ground such as a properly grounded outlet box as shown in Figure C, using a metal screw.

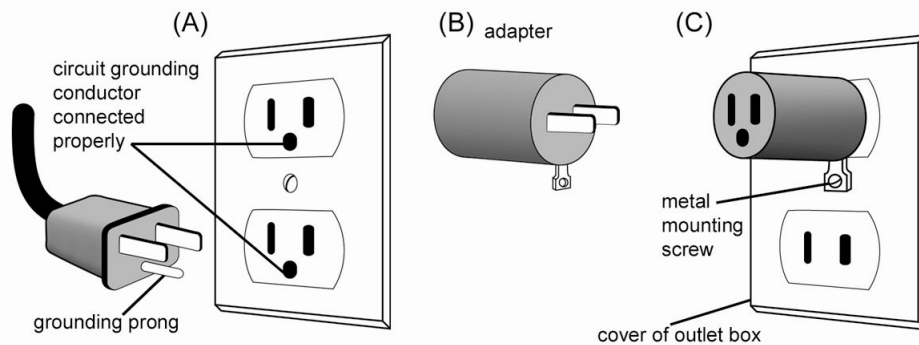

### LINE CORD SAFETY TIPS

1. Never pull or yank on cord or the appliance.
2. To insert plug, grasp it firmly and guide it into outlet.
3. To disconnect appliance, grasp plug and remove it from outlet.
4. Before each use, inspect the line cord for cuts and/or abrasion marks. If any are found, this indicates that the appliance should be serviced and the line cord replaced.
5. Never wrap the cord tightly around the appliance, as this could place undo stress on the cord where it enters the appliance and cause it to fray and break.

# PARTS

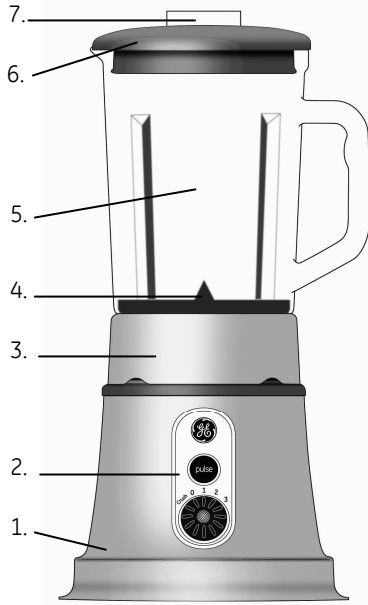

- 1. Die cast base
- 2. Control panel (see detail)
- 3. Jar collar
- 4. Blade assembly
- 5. Glass blending jar
- 6. Jar lid
- 7. Measuring cap
- 8. Cord storage (bottom of base)

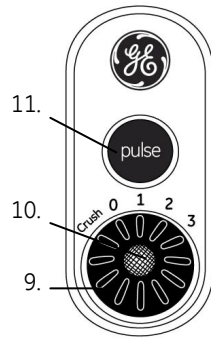

- On control panel**
- 9. Speed selector (0-3 and crush)
  - 10. Power indicator light
  - 11. Pulse button

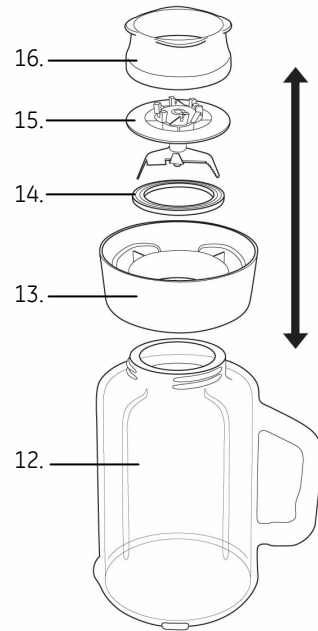

- Exploded view of glass jar**
- 12. Glass blending jar
  - 13. Jar collar
  - 14. Silicone sealing ring
  - 15. Blade assembly
  - 16. Black locking ring

# OPERATING INSTRUCTIONS

## Blending

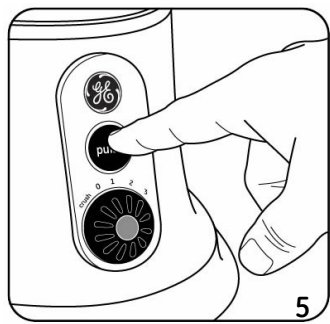
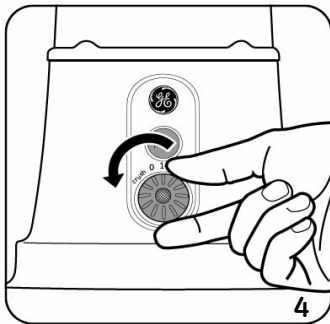
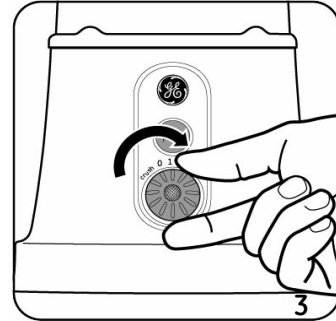
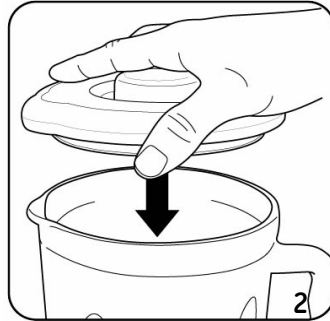

## Cleaning and Storage

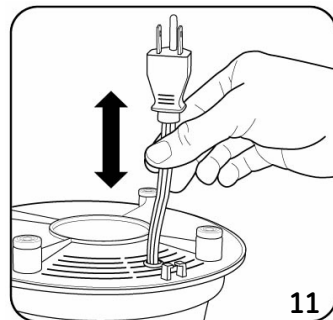
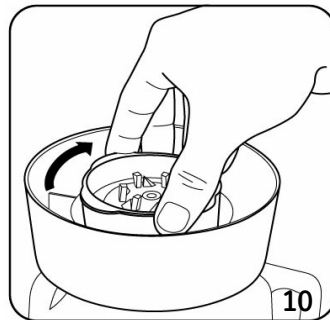
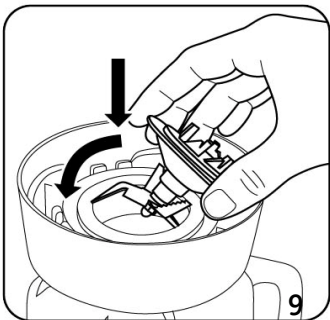
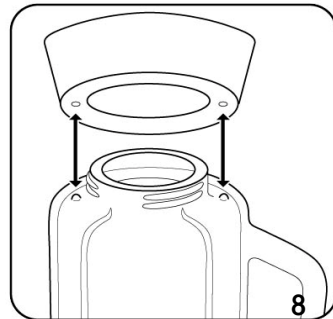
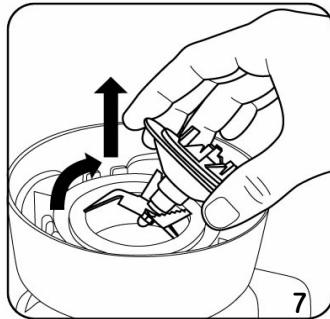
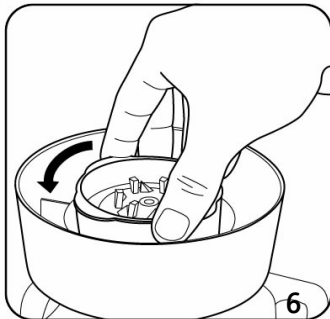

# INSTRUCTIONS FOR USE

For your safety, always read and understand this Instruction Manual before attempting to use any electric appliance.

## Before Using:

1. Carefully unpack the blender. Remove all packaging materials.
2. Wash the lid, measuring cap, blade assembly, and glass jar in hot soapy water. Dry thoroughly.
3. Wipe exterior surfaces of the base with a soft, moist cloth to remove residue that may have collected during packing and handling. Dry thoroughly. Do not use abrasive cleaners. NEVER IMMERSE THE BLENDER, CORD OR PLUG IN WATER OR ANY OTHER LIQUID.
4. Be sure all parts are properly assembled and in place before use.

## Blade Assembly:

**Note: Before blending, be sure the black locking ring is tightened to prevent leakage.**

1. Line up the two round indentions on the metal jar collar with the two round bumps on the glass blending jar (see figure 8).
2. Place the silicone sealing ring on the bottom of the glass jar.
3. Angle the blade assembly so one of the taller blades goes into the glass jar (see figure 9). Slowly lower the blade assembly so that the other blades enter the glass jar and the blade assembly sits flat on top of the silicone sealing ring.
4. Replace the black locking ring around the blade assembly and rotate the black locking ring clockwise until it is tightened (see figure 10).

Note: If you notice liquid leaking at the bottom of the glass blending jar, remove the black locking ring and re-tighten it.

## Blending:

1. Before starting, make sure the blender is in the **off** position. The **off** position is when the blue indicator dot on the speed selector knob aligns with the "0" marking.
2. Add ingredients to the blending jar (see figure 1).
3. Place lid on blending jar (see figure 2). Make sure the metal jar collar is properly seated on the die cast base.
4. Plug the power cord into a wall outlet. The blue power indicator light in the middle of the speed selector knob will illuminate, indicating the blender is ready for operation.  
**Note: The blue indicator light will remain illuminated until the appliance is unplugged from the wall outlet.**
5. Rotate the speed selector knob clockwise to select speeds 1 (low), 2 (medium), or 3 (high) (see figure 3). Rotate the speed selector knob counter-clockwise to select the **crush** setting (see figure 4).

**Crush Setting:** use this setting for ice crushing and chopping. The **crush** setting operates intermittently so the blender crushes at full power for about 3 seconds and then stops briefly before crushing at full power for another 3 seconds. The **crush** function will continue until the speed selector knob is returned to the "0" position. This operation allows the larger chunks of ice or other contents to settle back into the blade area for maximum blending performance.

- Pulse Button:** use this button to blend with a pulsing action. You can blend continuously by holding down the **pulse** button (see figure 5), or press and release the **pulse** button for multiple short bursts.
6. To stop blending, rotate the speed selector knob so the blue indicator dot is lined up with the off position "0".
  7. Be sure the blender is in the off "0" position when not blending.

## CLEANING AND STORAGE

This appliance requires little maintenance. It contains no user-serviceable parts. Do not attempt to repair it yourself. Any servicing that requires disassembly, other than cleaning, must be performed by a qualified appliance repair technician.

### To Clean:

1. Before cleaning, be sure the speed control dial is in the "Off" position and the cord is unplugged from the outlet.
2. To make cleaning easier, rinse the center measuring cap and jar lid immediately after use. Do not immerse the base in water or any liquid. If washing the jar by hand, wash in hot, soapy water. Rinse and dry thoroughly. If necessary, use a nylon bristle brush to clean the glass jar.
3. Do not use scouring pads or harsh chemicals on any plastic or metal parts.
4. Do not fill the jar with boiling water. Do not place any parts in boiling water.
5. Do not allow the blade assembly to soak in water for long periods of time.

### To Disassemble the Blade Assembly For Cleaning:

1. Remove the glass blending jar from the die cast base and turn it over.
2. Rotate the black locking ring counter-clockwise until you are able to remove it (see figure 6).
3. Carefully remove the blade assembly by lifting upward. Tilt the blade assembly to angle the blade out of the glass blending jar (see figure 7).
4. Remove the silicone sealing ring.
5. Lift the cast metal jar collar off the glass blending jar.

The glass jar is dishwasher safe. It is recommended to clean all other parts of the blade assembly by hand with warm, soapy water and dry with a towel or allow to air dry. Use caution when washing and cleaning the blade assembly as the blades are sharp.

### To Store:

Be sure all parts are clean and dry before storing. Store appliance in its box or in a clean, dry place. Never wrap cord tightly around the appliance; keep it loosely coiled or use the cord storage on the bottom of the blender (see figure 11).

# CUSTOMER ASSISTANCE

If you have a claim under this warranty, please call our Customer Assistance Number. For faster service, please have the model number and product name ready for the operator to assist you. This number can be found on the bottom of your appliance and on the front page of this manual.

**Model Number:** \_\_\_\_\_ **Product Name:** \_\_\_\_\_

Customer Assistance Number 1.877.207.0923 (US) or 1.877.556.0973 (Canada)

Keep these numbers for future reference!

For more information, please visit us at [www.gehousewares.com](http://www.gehousewares.com)

## TWO-YEAR LIMITED WARRANTY

### What does your warranty cover?

- Any defect in material or workmanship.

### For how long after the original purchase?

- Two years.

### What will we do?

- Provide you with a new one.
- For those items still under warranty but no longer available, WAL-MART reserves the right to replace with a similar GE branded product of equal or greater value.

### How do you make a warranty claim?

- Save your receipt.
- Properly pack your unit. We recommend using the original carton and packing materials.
- Return the product to your nearest WAL-MART store or call Customer Assistance at 1-877-207-0923 (U.S.) or 1-877-556-0973 (Canada).

### What does your warranty not cover?

- Parts subject to wear, including, without limitation, glass parts, glass containers, cutter/strainer, blades, seals, gaskets, clutches, motor brushes, and/or agitators, etc.
- Commercial use or any other use not found in printed directions.
- Damage from misuse, abuse, or neglect, including failure to clean product regularly in accordance with manufacturer's instructions.

### How does state law relate to this warranty?

- This warranty gives you specific legal rights, and you may also have other rights which vary from state to state or province to province.
- This warranty is in lieu of any other warranty or condition, whether express or implied, written or oral, including, without limitation, any statutory warranty or condition of merchantability or fitness for a particular purpose.
- WAL-MART, GE and the product manufacturer expressly disclaim all responsibility for special, incidental and consequential damages or losses caused by use of this appliance. Any liability is expressly limited to an amount equal to the purchase price paid whether a claim, however instituted, is based on contract, indemnity, warranty, tort (including negligence), strict liability, or otherwise. Some states or provinces do not allow this exclusion or limitation of incidental or consequential losses so the foregoing disclaimer may not apply to you.

### What if you encounter a problem with this product while using it outside the country of purchase?

- The warranty is valid only in the country of purchase and you follow the warranty claim procedure as noted.



is a trademark of General Electric Company and is used under the license by Wal-Mart Stores Inc., Bentonville, AR 72716

### Marketed in Canada by:

Wal-Mart Canada Corp.

1940 Argentia Road, Mississauga, Ontario L5N1P9