

INSTRUCTION BOOK

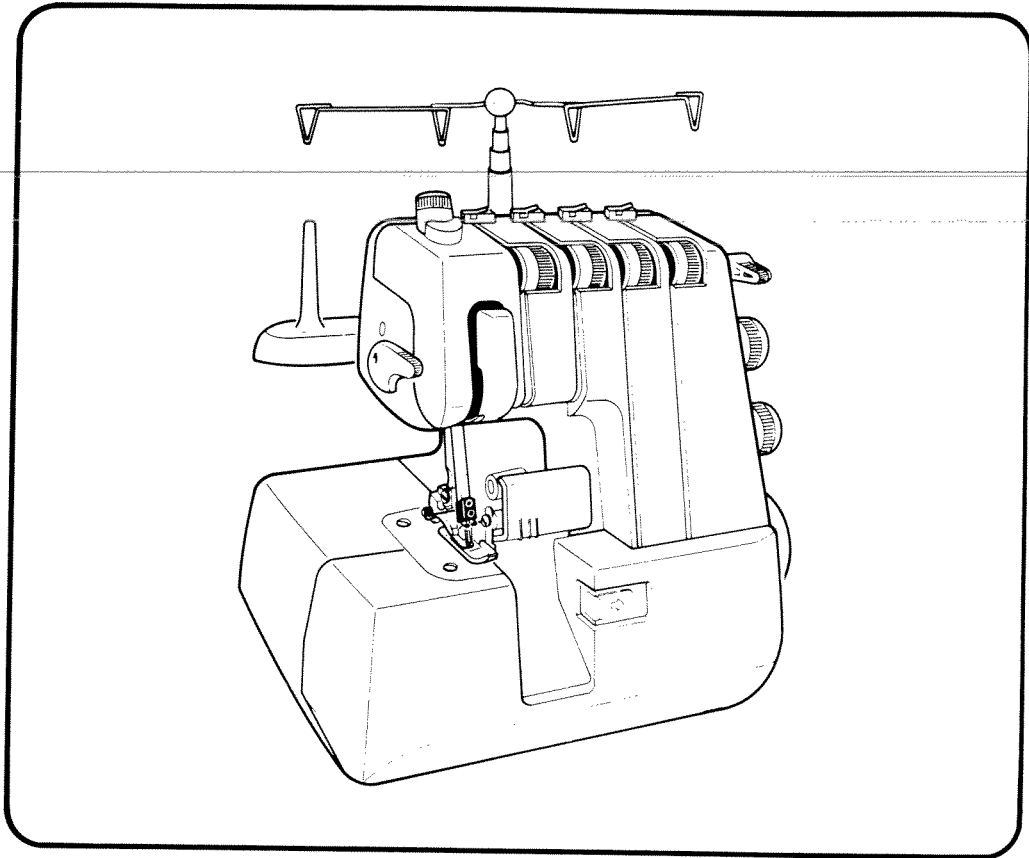

SUPERLOCK 634D
634DE

WHITE *Sewing machine company*

POLARIZED PLUG CAUTION

To reduce the risk of electric shock, this appliance has a polarized plug (one blade is wider than the other). This plug will fit in a polarized outlet only one way. If the plug does not fit fully in the outlet, reverse the plug. If it still does not fit, contact a qualified electrician to install the proper outlet. Do not change the plug in any way.

OVERLOCK SEWING MACHINE

Record in space provided below the Serial No. and Model No. of this appliance.

The Serial No. is located Rear of arm.

The Model No. is located Rear of arm.

Serial No. _____

Model No. **634D**

Retain these numbers for future reference.

IMPORTANT SAFETY INSTRUCTIONS

When using an electrical appliance, basic safety precautions should always be followed, including the following:

Read all instructions before using (this appliance).

DANGER --To reduce the risk of electric shock:

An appliance should never be left unattended when plugged in. Always unplug this appliance from the electric outlet immediately after using and before cleaning.

WARNING --To reduce the risk of burns, fire, electric shock, or injury to persons:

1. Do not allow to be used as a toy. Close attention is necessary when this appliance is used by or near children.
2. Use this appliance only for its intended use as described in this manual. Use only attachments recommended by the manufacturer as contained in this manual.
3. Never operate this appliance if it has a damaged cord or plug, if it is not working properly, if it has been dropped or damaged, or dropped into water. Return the appliance to the nearest authorized dealer or service center for examination, repair, electrical or mechanical adjustment.
4. Never operate the appliance with any air openings blocked. Keep ventilation openings of the sewing machine and foot controller free from the accumulation of lint, dust, and loose cloth.
5. Never drop or insert any object into any opening.
6. Do not use outdoors.
7. Do not operate where aerosol (spray) products are being used or where oxygen is being administered.
8. To disconnect, turn all controls to the off ("0") position, then remove plug from outlet.
9. Do not unplug by pulling on cord. To unplug, grasp the plug, not the cord.

DANGER

1. Always unplug before relamping. Replace bulb with same type rated 15 watts.
2. Do not reach for an appliance that has fallen into water. Unplug immediately.
3. Do not place or store appliance where it can fall or be pulled into a tub or sink. Do not place in or drop into water or other liquid.

WARNING

1. Keep fingers away from all moving parts. Special care is required around the sewing machine needle.
 2. Always use the proper needle plate. The wrong plate can cause the needle to break.
 3. Do not use bent needles.
 4. Do not pull or push fabric while stitching. It may deflect the needle causing it to break.
 5. Switch the sewing machine off ("0") when making any adjustments in the needle area, such as threading needle, changing needle, or changing presser foot, etc.
 6. Always unplug sewing machine from the electrical outlet when removing covers, lubricating, or when making any other user servicing adjustments mentioned in the instruction manual.
 7. Never operate on a soft surface such as a bed or couch where the air openings may be blocked.
-

SAVE THESE INSTRUCTIONS

CONTENTS

1. NAMES OF PARTS.....	1
2. OPERATION AND FUNCTION OF PARTS.....	2
3. PREPARATION FOR SEWING.....	4
3-1. Connecting Power Cord.....	4
3-2. Setting Telescopic Thread Stand.....	5
3-3. Changing Threads.....	5
3-4. Replacing Needle.....	6
3-5. Threading.....	7
4. FOUR THREAD OVERLOCK STITCH USING 2 NEEDLES.....	10
4-1. Before Sewing.....	10
4-2. Setting the Fabric.....	10
4-3. Beginning and Ending of Sewing.....	10
4-4. Adjustment of the Presser Foot Pressure.....	11
4-5. Thread Tension Chart.....	12
4-6. Thread Tension Adjustment.....	13
5. ADJUSTING BALANCE OF STITCH WIDTH AND CUTTING WIDTH.....	15
6. STITCH LENGTH ADJUSTMENT.....	15
7. DIFFERENTIAL FEED.....	16
8. CORDED OVERLOCK.....	17
9. SEWING FOR CURVED SEAMS.....	17
10. THREE THREAD OVERLOCK STITCH USING 1 NEEDLE.....	18
11. ROLLED EDGE.....	19
12. PIN TUCKS.....	20
13. REPLACING LOWER CUTTER.....	21
14. CHANGING LIGHT BULB.....	21
15. LUBRICATION.....	21
16. ACCESSORIES.....	23
17. TABLE OF SEWING MATERIALS, NEEDLES AND THREADS.....	24
18. PROBLEM SOLVING.....	25
19. SPECIFICATIONS.....	26
20. OPTIONAL ACCESSORY PRESSER FEET.....	27

1. NAMES OF PARTS

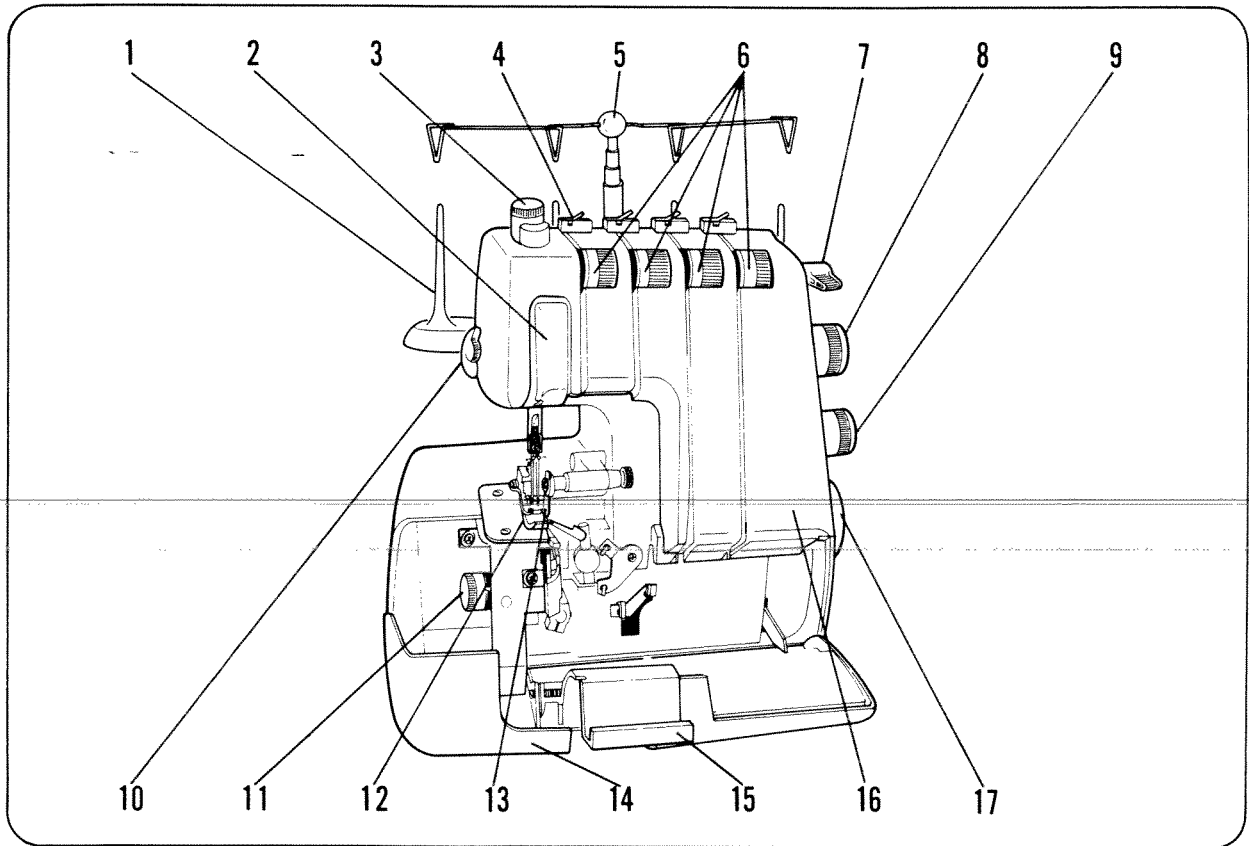

1. Spool pin
2. Thread take up lever cover
3. Pressure regulator screw
4. Thread tension support
5. Telescopic thread stand
6. Thread tension dials
7. Tension release lever
8. Differential feed dial
9. Stitch length dial
10. Presser foot lifter
11. Cutting width adjusting dial
12. Presser foot
13. Upper cutter
14. Front cover
15. Cutter cover
16. Front panel
17. Handwheel (Right side of machine)

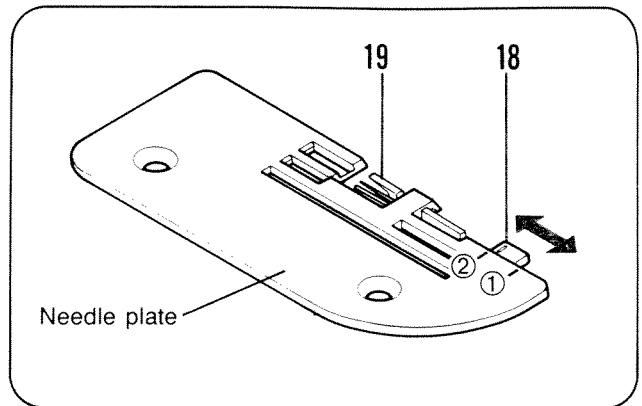

2. OPERATION AND FUNCTION OF PARTS

Handwheel

✦ Always turn handwheel toward you.

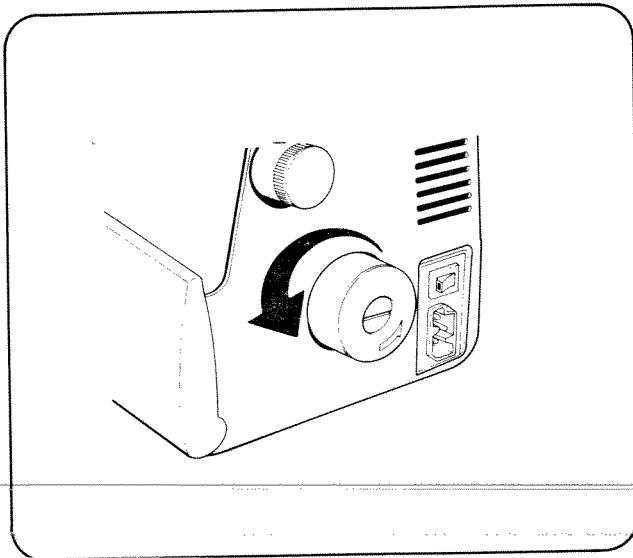

Changing Presser Foot

✦ Switch off the machine.

1. Raise presser foot.
2. Raise needles to their highest position by turning handwheel toward you.
3. Push red button A and foot will come off.
4. Position the new foot with the pin right under the groove of the ankle. Lower presser foot lifter so that holder catches the presser foot.

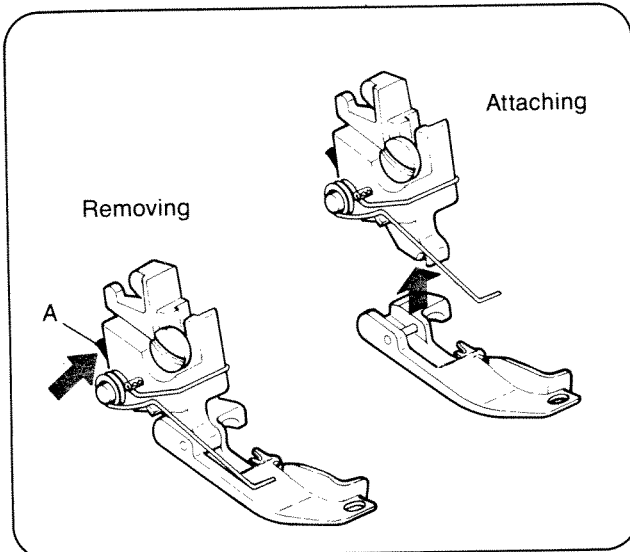

Opening Front Cover

To open front cover, push part B of cutter cover to right and pull it down toward you.

Closing Front Cover

Push part B and close it.

✦ Always close front cover when sewing.

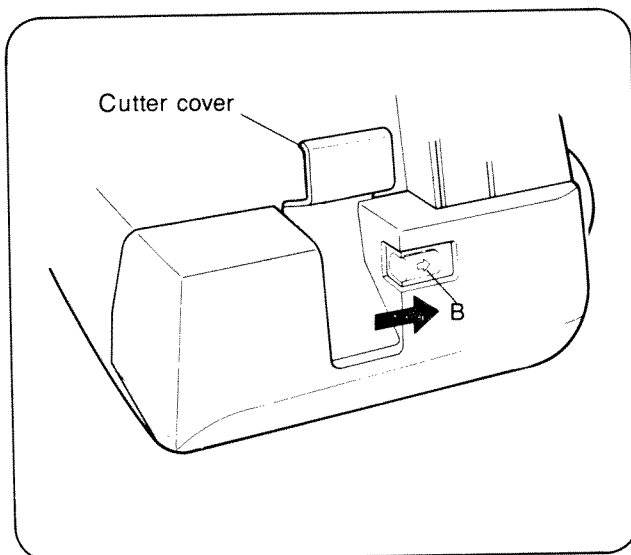

Stitch Finger Knob

(Conversion from overlock to rolled edge)

✦ Raise needle to the highest position by turning handwheel toward you.

For Overlock:

Push stitch finger knob to align it with the rear red line ② on needle plate.

For Rolled Edge:

Pull stitch finger knob toward you to align it with front red line ① on needle plate.

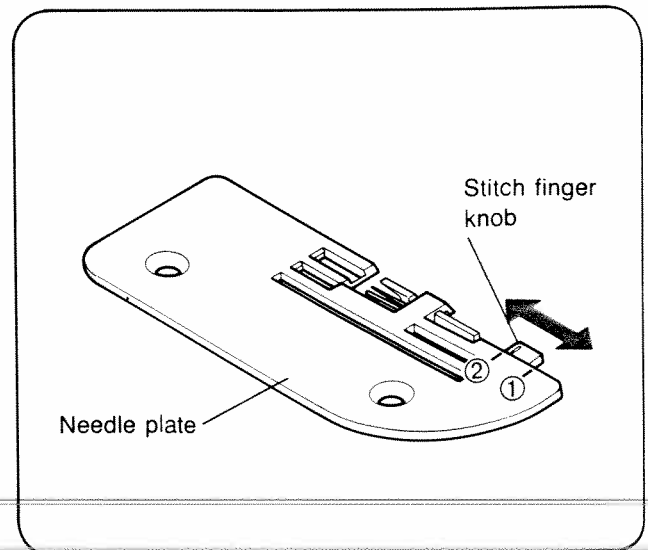

Presser Foot Lifter

Raise the presser foot lifter to lift up the presser foot.

Presser foot lifter stops at position A.

When replacing presser foot or sewing very thick materials, presser foot lifter can be lifted up one more step to obtain wider gap.

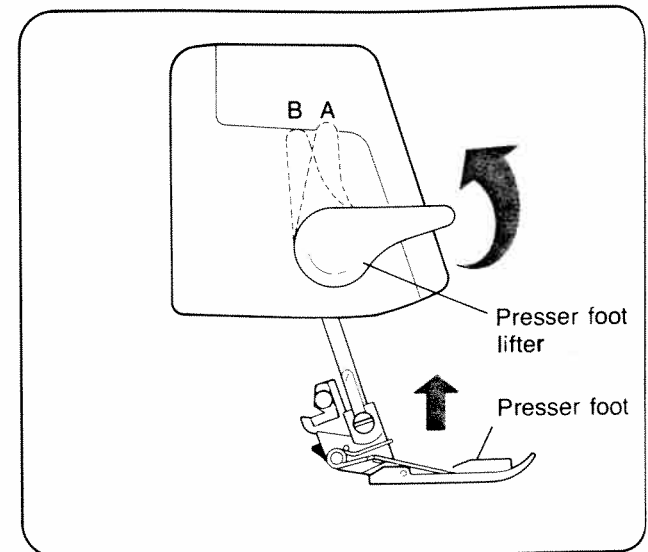

Disengaging Upper Cutter

For ease in threading, push the upper cutter holder screw from A side with the forefinger of your left hand ✦ and grasp the right end of the holder C, and turn it in the direction of arrow B with your right hand.

✦ Since the upper cutter is sharp, care should be taken when moving this part.

Be sure to put cutter back down before sewing.

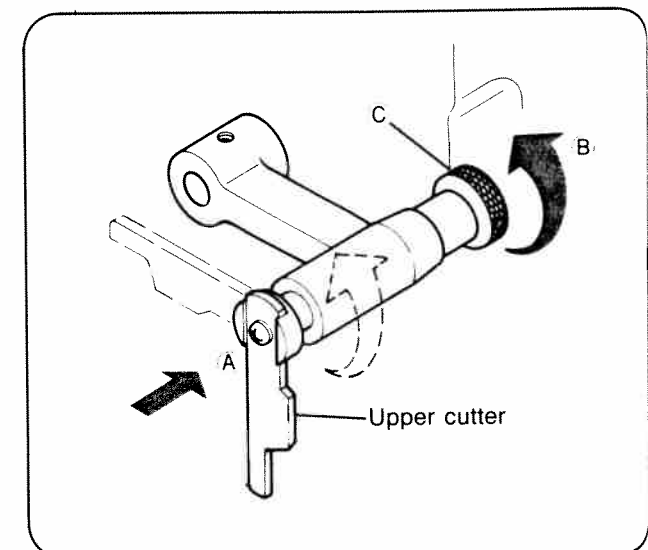

3. PREPARATION FOR SEWING

3-1. Connecting Power Cord

Connect foot control and power cord ① ②.

Before plugging in your machine, be sure that the voltage is same as that of your machine. (written on a plate at back of machine).

* Specifications vary from country to country.

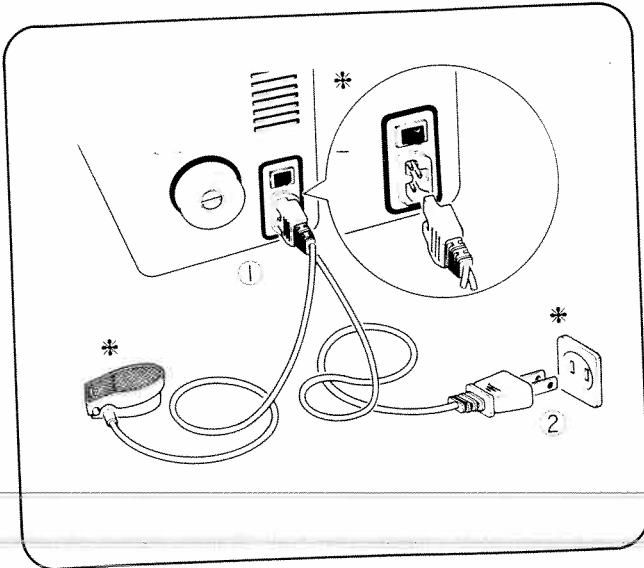

Press the switch on the machine to turn on the power and the sewing light.

* Always switch off or unplug machine when not in use.

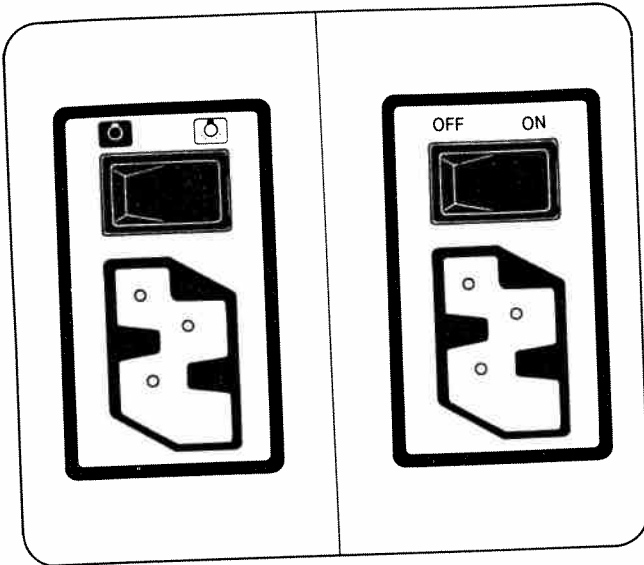

The more you press the foot control, the faster the machine runs.
When the power switch is turned off, the machine will not operate even by pressure on the foot control.

* DO NOT put anything on foot control.

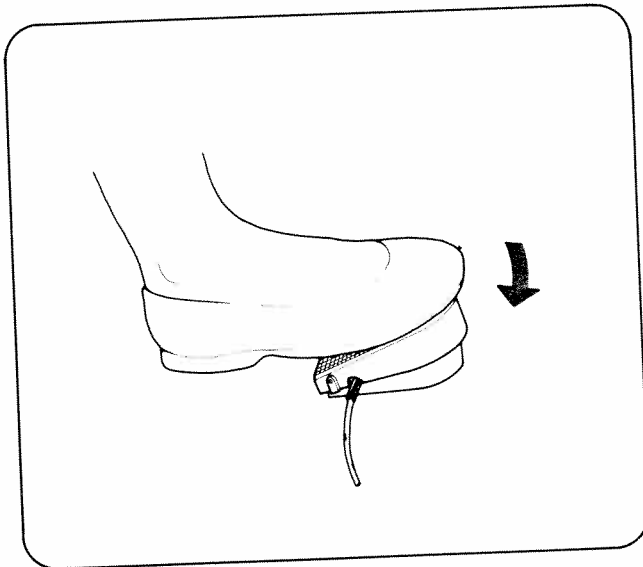

3-2. Setting Telescopic Thread Stand

Extend the telescopic thread stand to its full height, then turn it until the shaft clicks into its locked position.

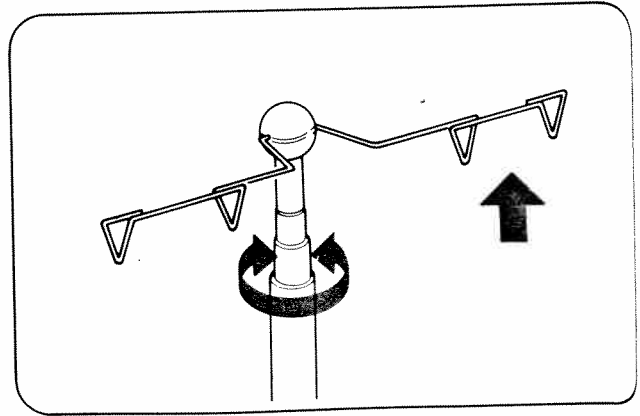

3-3. Changing Threads

The machine is supplied with thread but the following is an easy way to change them:

(1) Cut the thread in use near the cone spool (behind the telescopic thread stand). Place the new thread on the spindle and tie it to the end of the original thread.

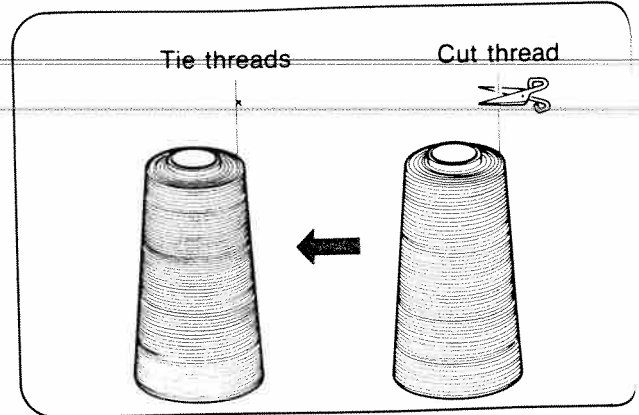

(2) Raise the presser foot lifter to lift up the presser foot.

(3) Press down the tension release lever so that the thread knot can pass through smoothly, draw out the looper thread until the thread knot comes to about 10 cm past the presser foot.

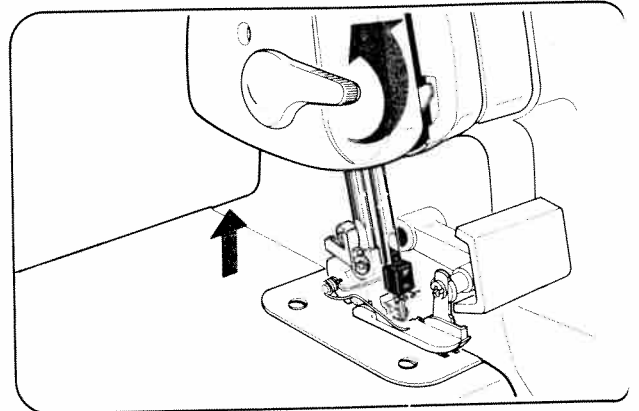

(4) When changing the needle thread, cut off the thread knot before it reaches the eye of the needle to avoid bending the needle as the knot is pulled and caught in the needle's eye.

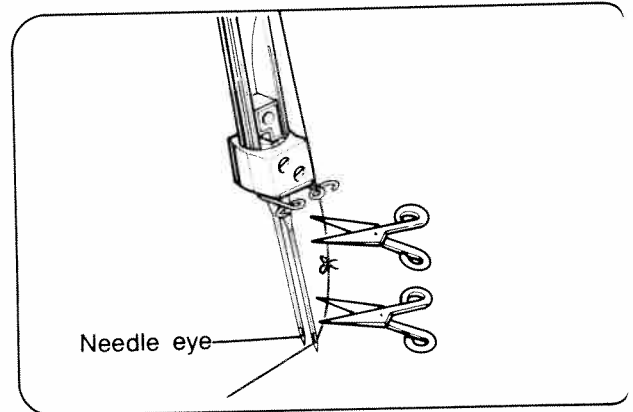

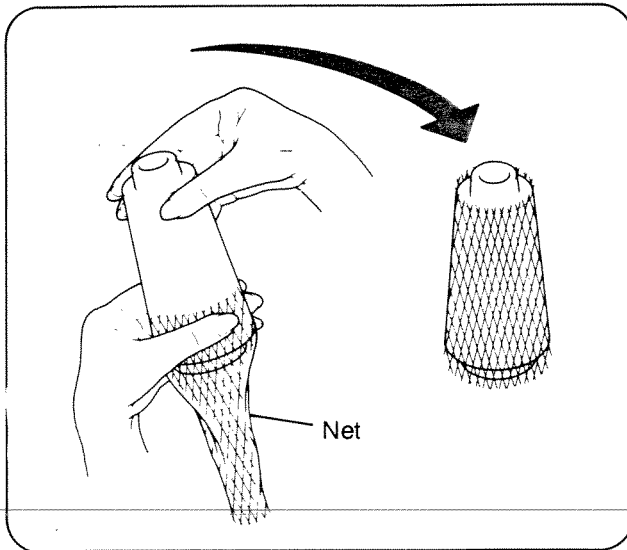

Cover the spool with the "NET" as needed to prevent thread from slipping down on thread cones.

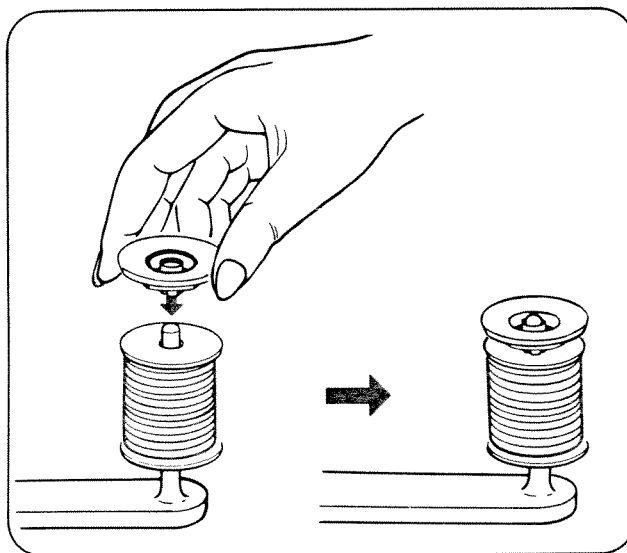

When using a standard type thread spool, insert the spool adapter (supplied with the machine) (as shown).

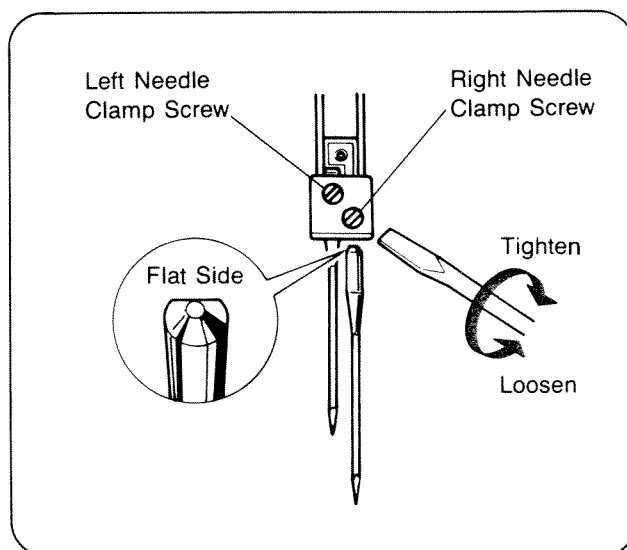

3-4. Replacing Needle

Replace needle in the following way:

Note: be sure to take out the power supply plug before replacing needle.

- (1) Bring needle to its highest position by turning handwheel towards you.
- (2) When replacing right needle, loosen right needle clamp screw and remove needle. For left needle replacing, loosen left needle clamp screw.
- (3) With the flat side away from you, insert the new needle into groove of needle bar as far as it will go.

Use "HA×1 #11 ~ #14" (SCHMETZ 130/705H. NO: 75 ~ 90)

These are the same as for home-use sewing machine.

3-5. Threading

When threading the machine from the beginning, threading must be carried out in the following sequence:

First: Lower looper threading (A)

Second: Upper looper threading (B)

Finally: Needle threading (C, D)

(1) Lower looper threading (A)

Open front cover. (See Page 2)

Take the thread drawn from the spool and pass it, through guide ① of the thread stand and then, in order, through guides ② ~ ⑨ and thread tension dial ③. (Fig. A)

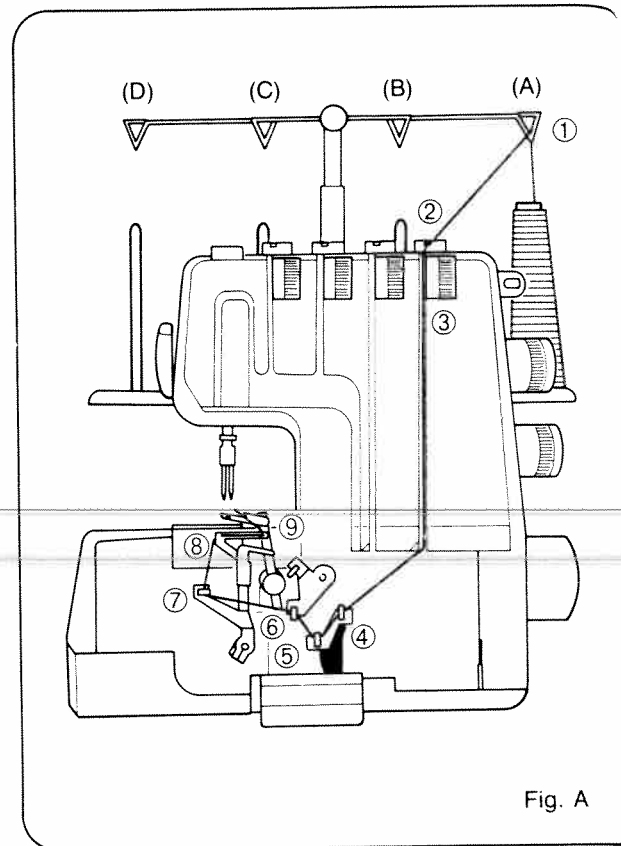

Fig. A

While pressing down the tension release lever with your right hand, lay thread between thread tension discs with your left hand. (Fig. B)

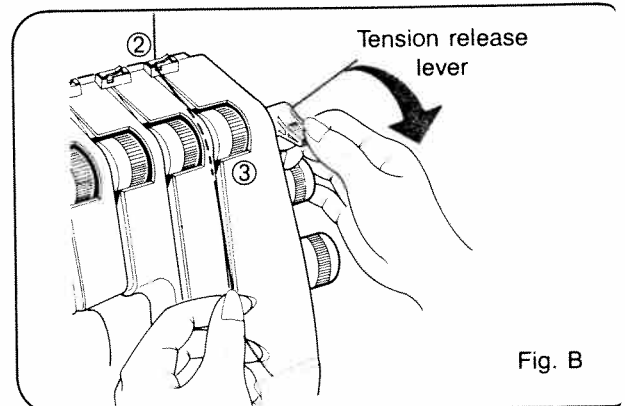

Fig. B

Bring the lower looper to the far left position by turning handwheel towards you, and pass the thread through lower looper thread guide ⑦ (Fig C)

Hook thread around part ⑧ from back to front as illustrated.

Then, move the lower looper slightly to the right by turning the handwheel towards you.

Thread the hole of the lower looper ⑨, using tweezers.

Cut the thread leaving about 10cm (4") of spare thread. (Fig. D)

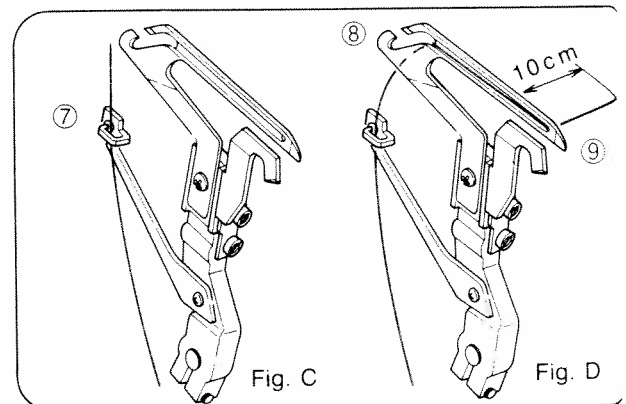

Fig. C

Fig. D

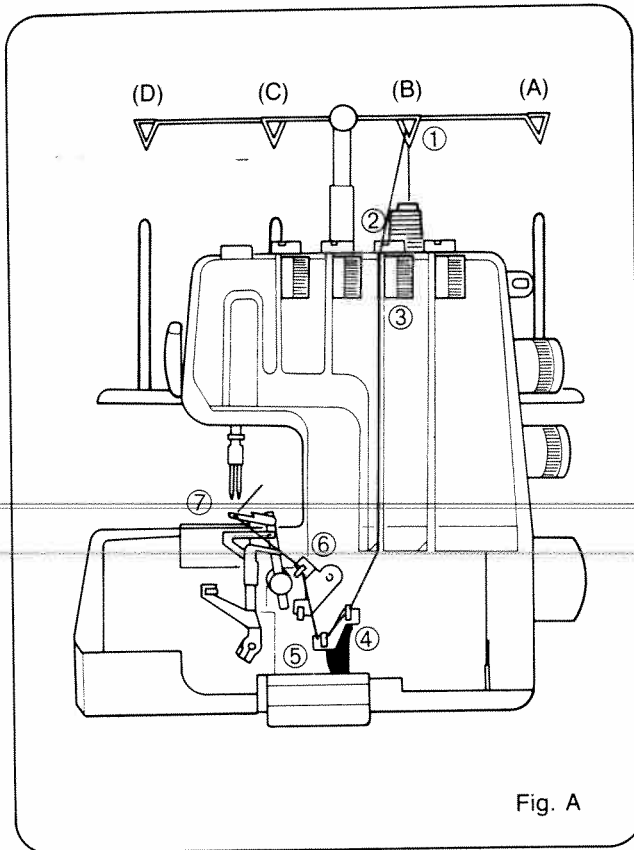

Fig. A

(2) Upper looper threading (B)

Bring the upper looper to its lowest position by turning handwheel toward you.

Draw thread from spool and pass it, through guide ① of the thread stand and then, in order, through guides ② ~ ⑦. (Fig. A)

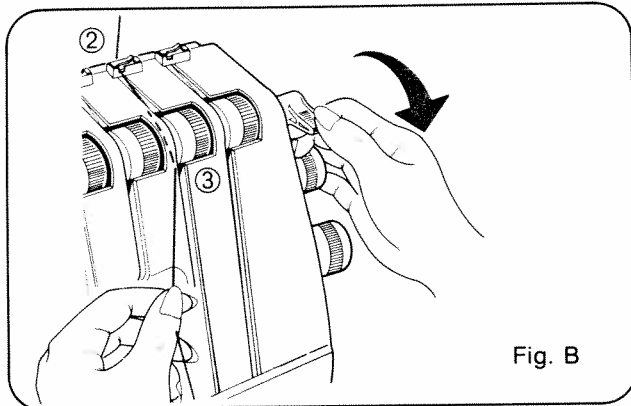

Fig. B

While pressing down the tension release lever with your right hand, lay thread between thread tension discs with your left hand. (Fig. B)

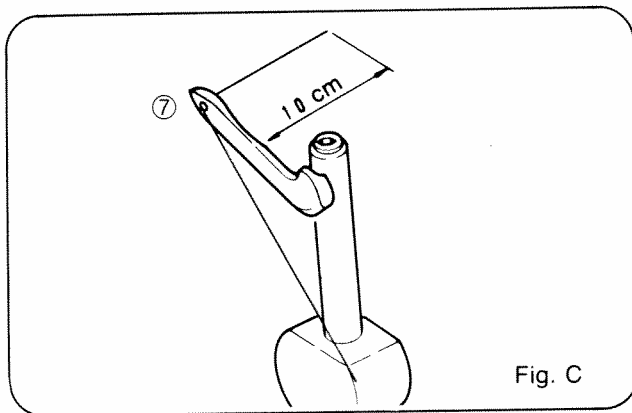

Fig. C

Thread the hole of upper looper ⑦ using tweezers. Cut the thread leaving about 10cm (4") of spare thread. (Fig. C)

Close the front cover.

(3) Needle Threading (C) (D).

* For ease in threading, turn the moveable cutter to the non-operating position. (See Page 3).

1. Raise the needles to their highest position.
2. Draw thread from spool and pass it through guide ②.
3. Lay thread between thread tension discs ③ while pressing down the tension release lever.
4. Pass thread through guides ④, ⑤, ⑥ for right needle thread.
Pass thread through guides ⑤, ⑥ for left needle thread. (Fig A)

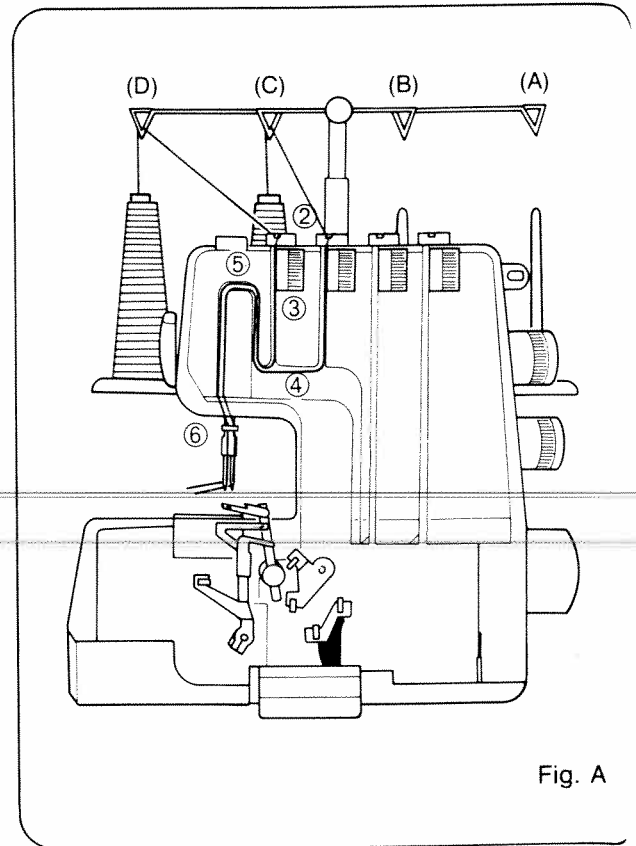

5. Then thread each needle's eye ⑦.
Cut the thread leaving about 10cm (4") of spare thread.
Use tweezers for easy threading to needle's eye.

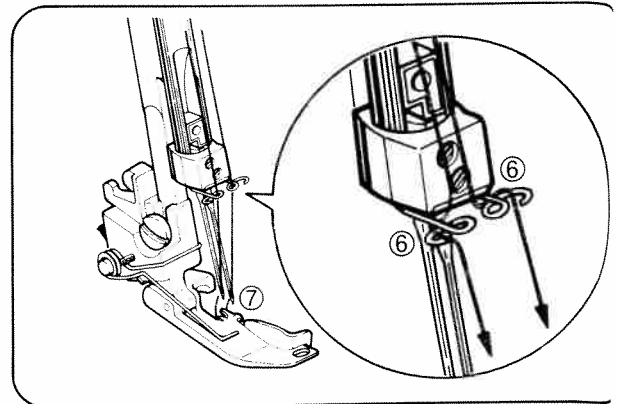

Preparation for Sewing and Checking

Check that no thread slips off guides, or breaks. Confirm that the upper cutter moves against the lower cutter correctly by turning the handwheel slowly towards you. If it is not correct, check if there is any fabric or waste thread between cutters. Turn the handwheel towards you with your right hand to check that the thread winds around the stitch finger of the needle plate. If the thread doesn't wind around the stitch finger of the needle plate, check if any threads are threaded incorrectly.

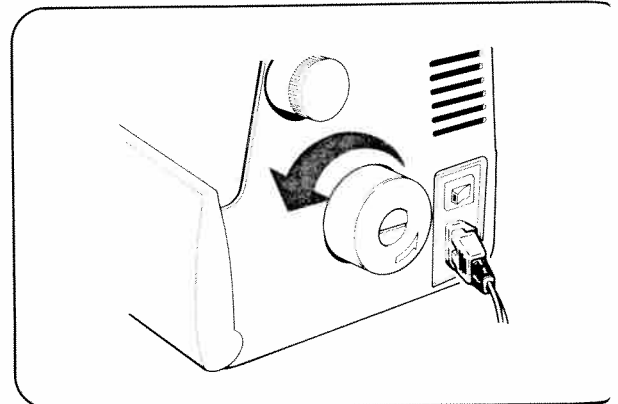

4. FOUR THREAD OVERLOCK STITCH USING 2 NEEDLES

4-1. Before Sewing

After threading is completed, and when the threads are not wound around the stitch finger, gently draw out the four threads under and behind the presser foot, and turn the handwheel towards you by hand two or three times to make stitch form on the stitch finger.

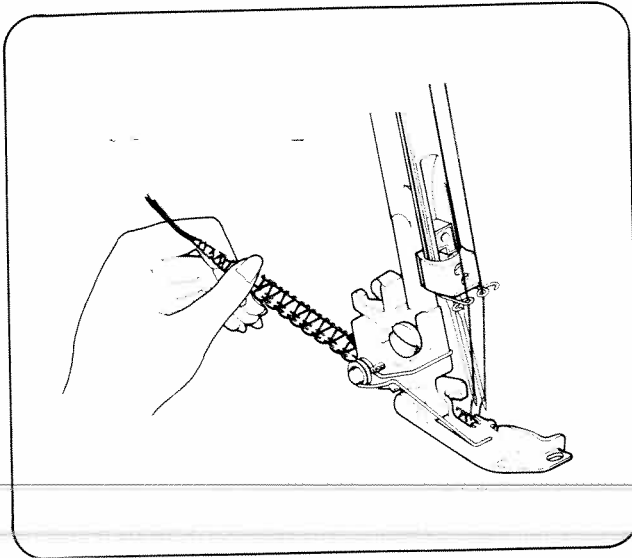

4-2. Setting the Fabric

When beginning to sew, place the material just ahead of the presser foot and it will be fed through. There is no need to raise the presser foot lifter.

For setting the very thick material; Raise presser foot lifter to lift up the presser foot. Place the material under the presser foot and push it to the front of the cutter and lower presser foot before sewing.

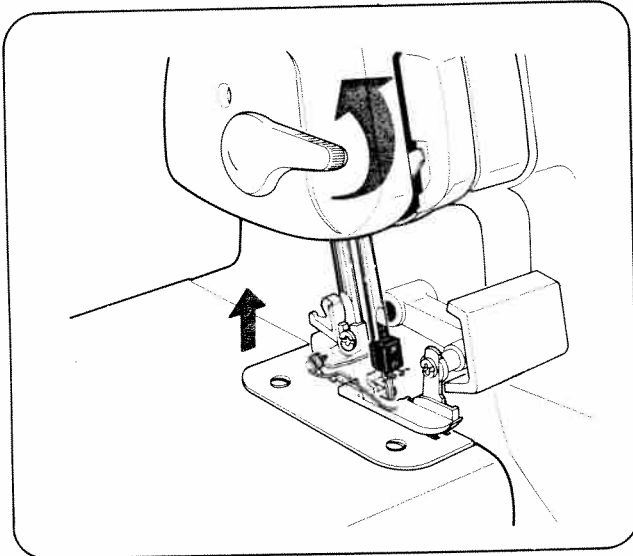

4-3. Beginning and Ending of Sewing

(1) Beginning to sew

Place the material under the toe of the presser foot and begin sewing slowly.

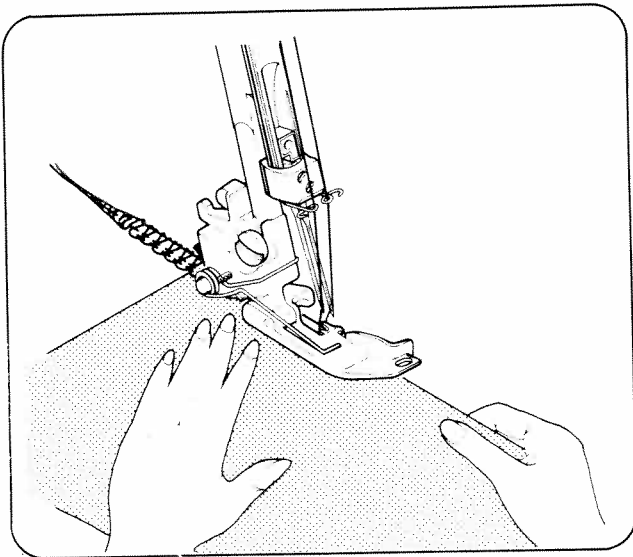

(2) Ending of sewing

Sew off the material forming a chain to prevent the thread from untying and to prepare for the next sewing.

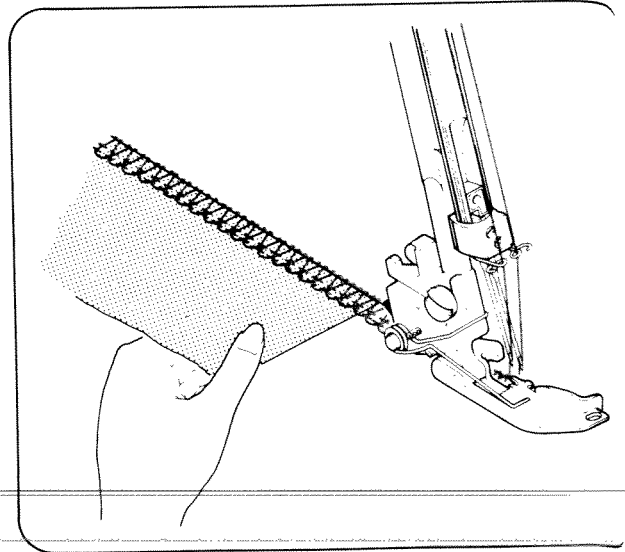

Draw the finished fabric gently backwards and to the left as the machine is operating and make chain-stitches. This is called chain-stitch sewing. Then cut the thread 5 ~ 6cm (2") from the presser foot.

* Do not pull it out roughly as the needle will bend and break.

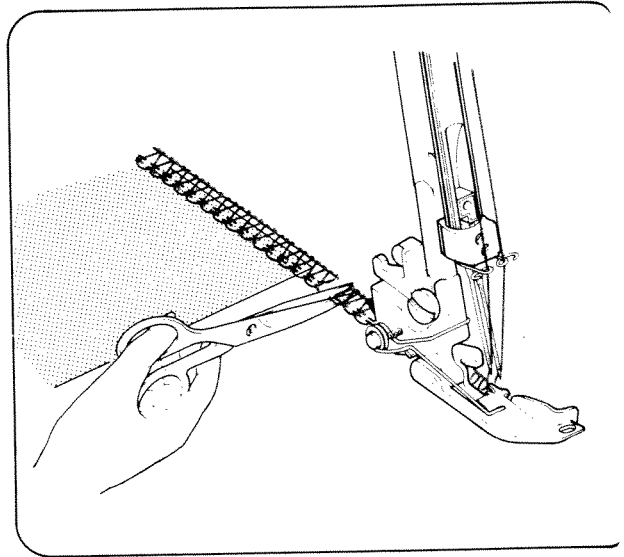

4-4. Adjustment of the Presser Foot Pressure

The presser foot pressure is pre-adjusted for materials of medium (standard) thickness. Adjustment is necessary only when you work on very thin or very thick materials. Accordingly, sew thinner materials with less pressure and thicker materials with more pressure. Increase the pressure of the presser foot by tightening the adjustment screw.

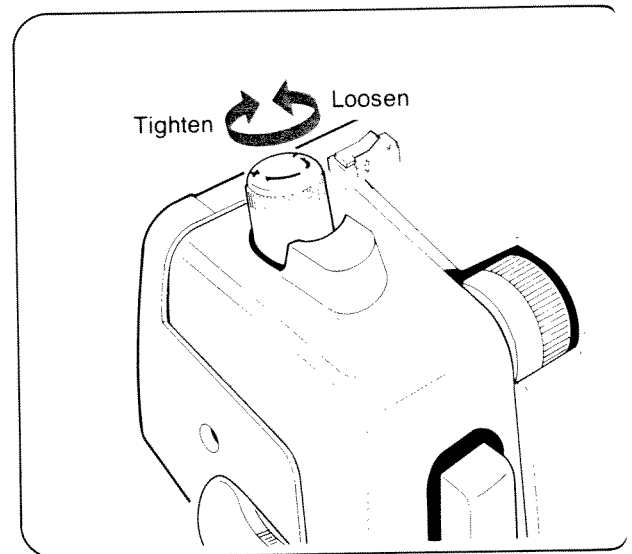

4-5. Thread Tension Chart

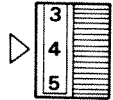
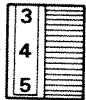
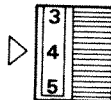
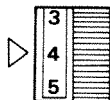
THREAD TENSION PATTERN STITCHES	Left Needle 	Right Needle 	Upper Looper 	Lower Looper 	STITCH LENGTH	CUTTING WIDTH
OVERLOCK	4	4	4	4	2.5-5 mm	5-6 mm
ROLLED EDGE	—	4	4	8	1-1.5 mm	5-6 mm
FINE ROLLED EDGE	—	4	4	4	1-1.5 mm	5-6 mm

The tension for each of the thread tension dials should be different according to the pattern stitches as in the chart above.

Since the figures in the chart are for average strength of thread tension, it may be necessary to adjust the thread tension slightly.

Thread tensions will differ according to the kind of fabric and the thread.

The differential feed ratio is normally "N". (See P.16)

4-6. Thread Tension Adjustment

Set the balance of the tension as weak as possible.
To tighten the tension, turn tension dial to a higher number.

To loosen the tension, turn tension dial to a lower number.

- ① Left needle thread tension
- ② Right needle thread tension
- ③ Upper looper thread tension
- ④ Lower looper thread tension

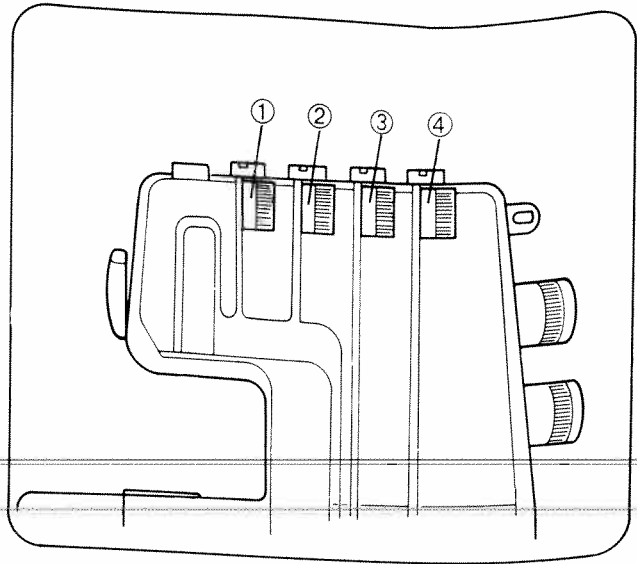

(1) Correct tension.

- Lower looper thread and upper thread should be well balanced with same tension. (Both looper threads should make crosses at the edge of the fabric.)
- Needle thread should not be slacken, or pulled.

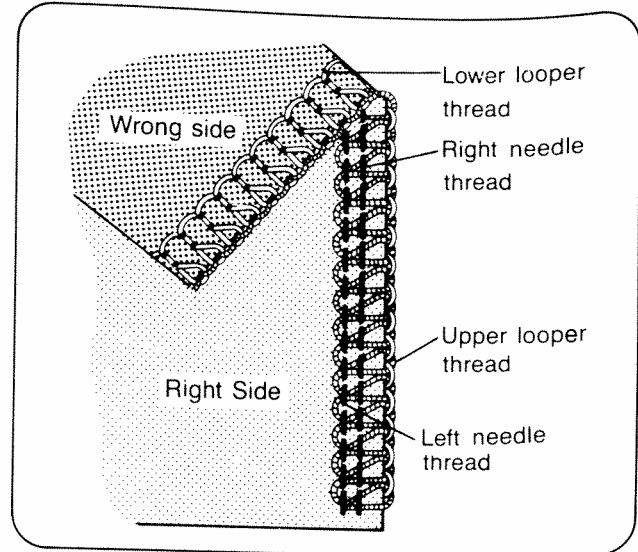

(2) Unbalanced upper looper thread wraps round and over the back:

Tighten the thread tension of the upper looper (Dial ③) or loosen the thread tension of the lower looper (Dial ④).

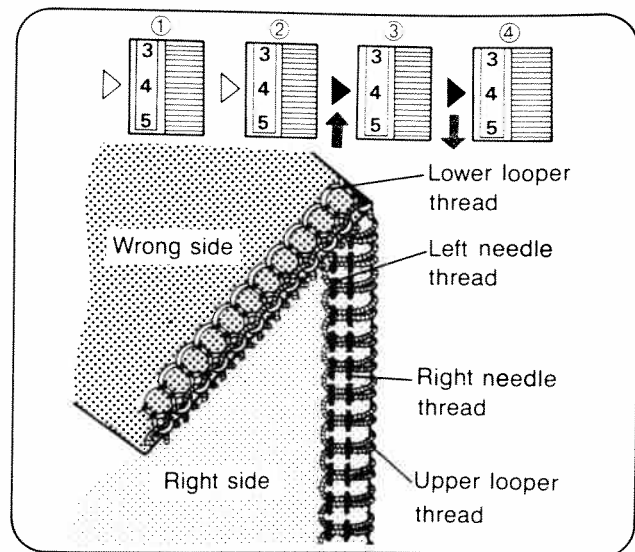

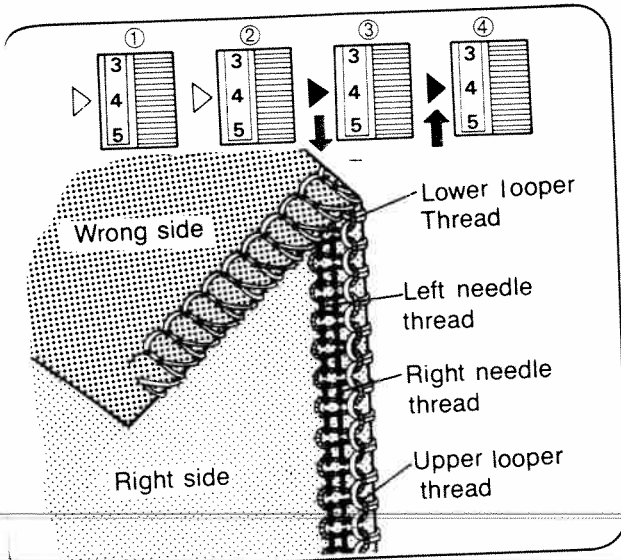

(3) Unbalanced lower looper thread wraps round and over the face:

Tighten the thread tension of the lower looper (Dial ④) or loosen the thread tension of the upper looper (Dial ③).

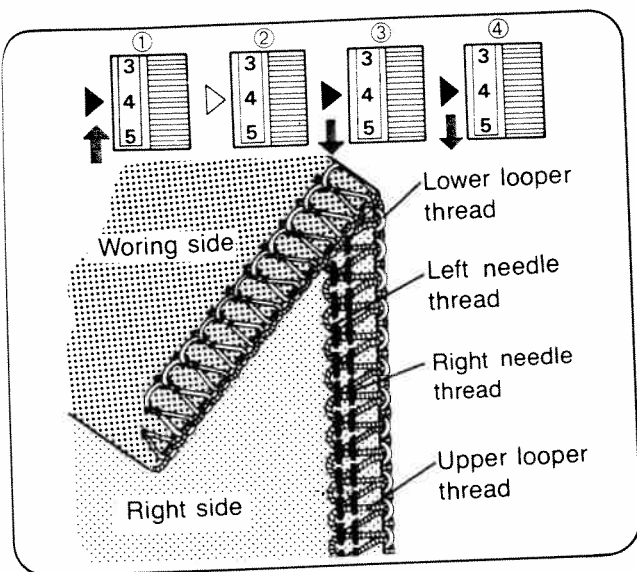

(4) Unbalanced left needle thread too loose:

Tighten the thread tension of the left needle (Dial ①) or loosen both looper threads (Dial ③ and ④).

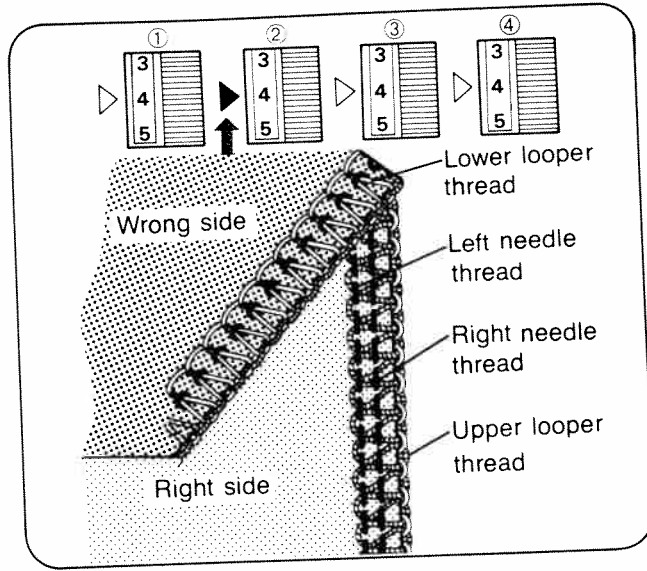

(5) Unbalanced right needle thread too loose:

Tighten the thread tension of the right needle (Dial ②).

5. ADJUSTING BALANCE OF STITCH WIDTH AND CUTTING WIDTH

- Adjust the cutting width from 5.2 (0.2") to 7.0mm (0.28") according to the kind of material.
 - The standard cutting width is 5.5mm (0.21").
 - Open the front cover to adjust the cutting width.
- (1) If the cutting width is narrower than the stitch width, leaving loops off the fabric edge, turn the cutting width adjusting dial to the direction of arrow. (To a bigger number)

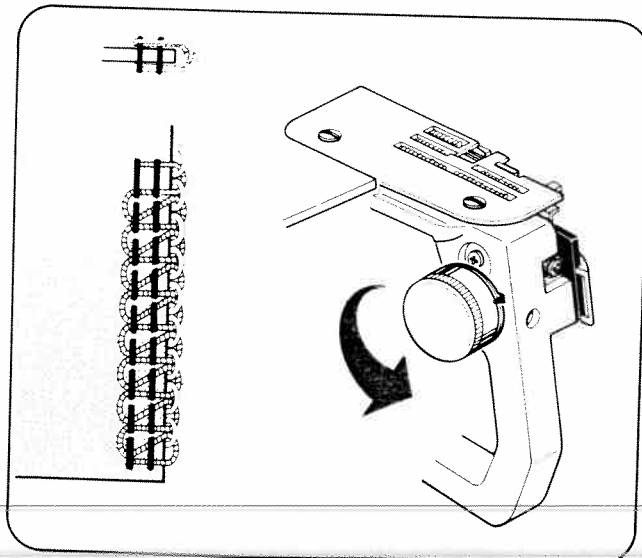

- (2) If the cutting width is wider than the stitch width, causing a pucker within the overlock seam, turn the cutting width dial to the direction of the arrow. (To a smaller number)

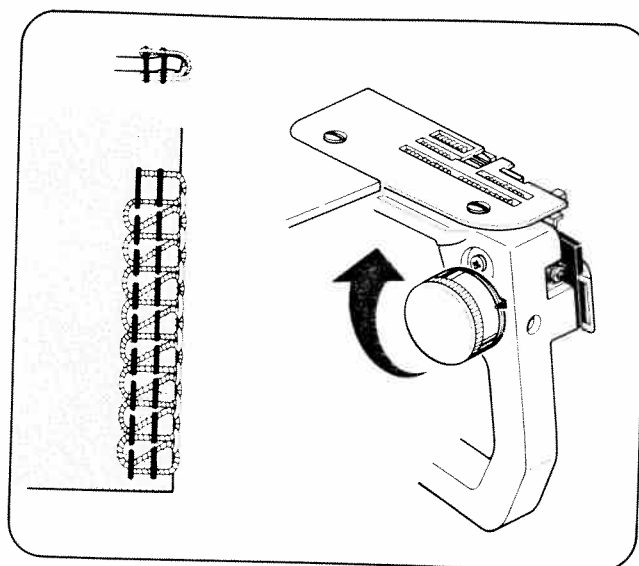

6. STITCH LENGTH ADJUSTMENT

The machine is pre-set to a 2.5mm stitch length for regular seaming and overlock. You may adjust the stitch length from 1mm (Narrow rolled edge) to 5mm by one-touch of the stitch length dial.

- ✦ For normal overlock set the stitch length from 2.5mm to 5mm. A stitch length less than 2.5mm is used only for rolled edge.

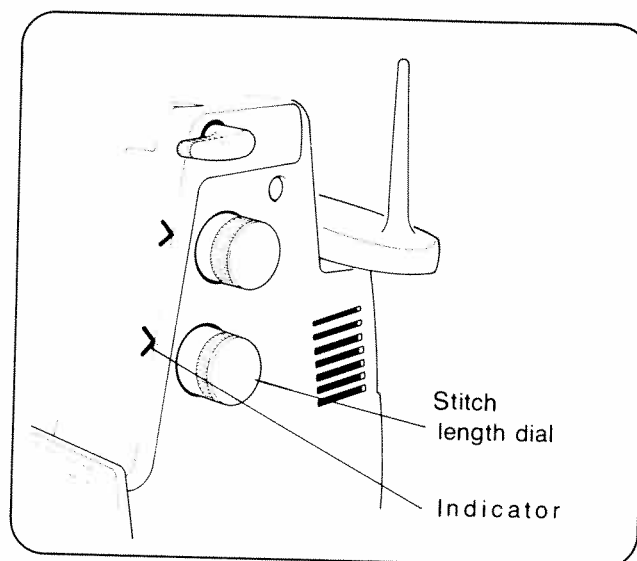

7. DIFFERENTIAL FEED

Differential feed prevents stretching or puckering fabrics, since two independent feed dogs, one in front and one behind the needles, can be adjusted to feed at different ratio.

This function produces a neat finish of overlock for stretchable and lightweight fabrics.

* "N" indicates the normal position.

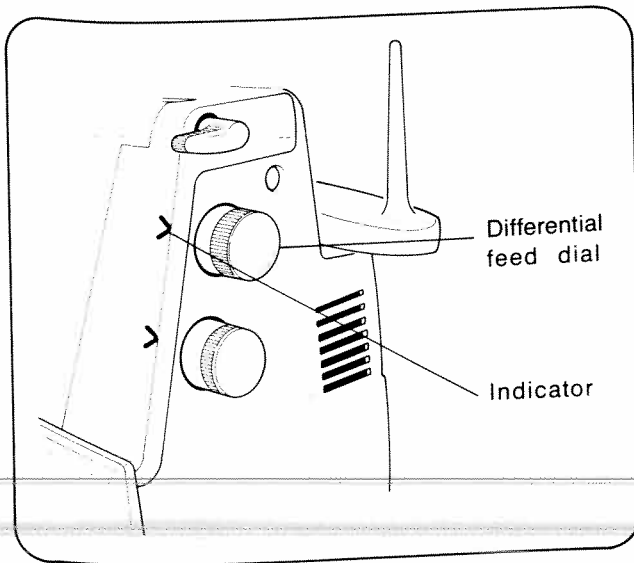

Refer to the chart below and test stitch performance on a scrap of material you are going to use.

	Fabric	Differential feed ratio is set "N".	Differential feed ratio	Result of adjustment
Stretchable materials	Knit Jersey		N-2	
Normal materials	Medium woven fabrics		N	
Very lightweight materials	Georgette		0.7-N	

8. CORDED OVERLOCK

Corded overlock can be used to strengthen and stabilize stitches when joining elastic materials such as knitted fabrics.

There are two ways of corded overlock.

- (1) Place the narrow cord (about 3mm) into the hole in the foot and back under the foot, then sew with the right needle stitching through the cord.
- (2) Sew over a narrow cord, positioning it on the edge of the overlocked stitch.

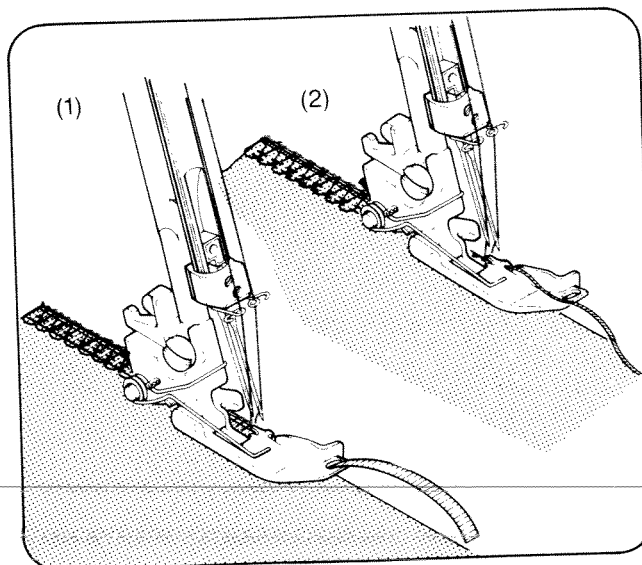

9. SEWING FOR CURVED SEAMS

For a neat and clean finish of curved seams:
For inside curves, guide the fabric gently with the trimming line of the fabric under the right front of the presser foot, applying pressure to the fabric with your left hand, at the same time, apply a little pressure in the opposite direction with your right hand to hold it against the cutter as shown.

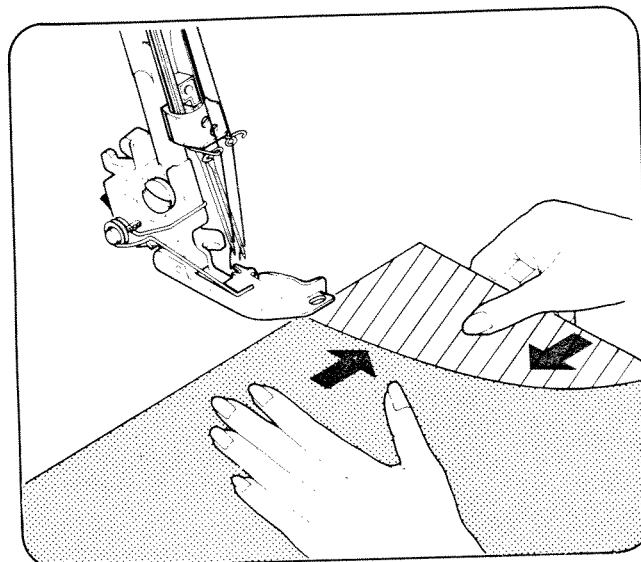

For outside curves, apply pressure in the opposite directions of the above.

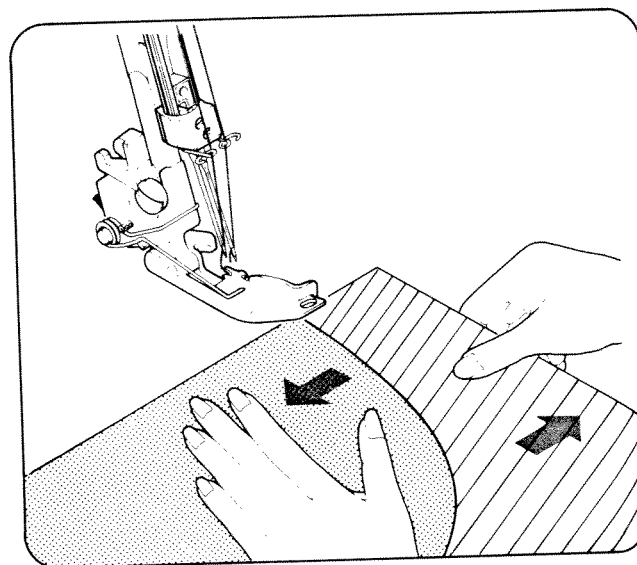

10. THREE THREAD OVERLOCK STITCH USING 1 NEEDLE

Though this machine is made mainly for 4 thread stitch overlock using 2 needles.

To sew three-thread stitch overlock using 1 needle simply remove 1 needle.

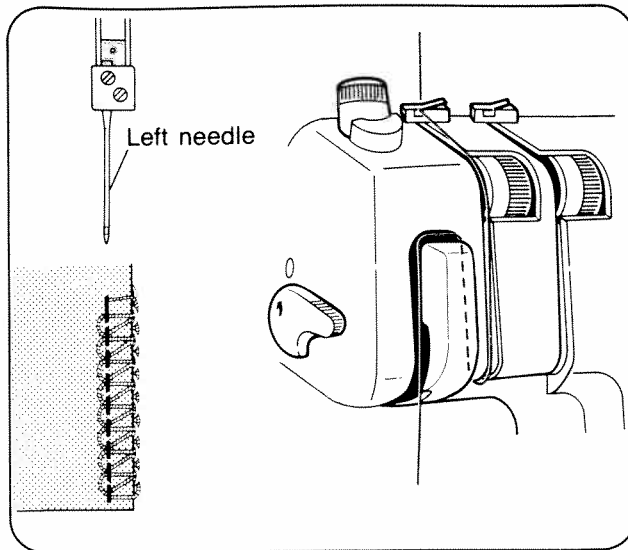
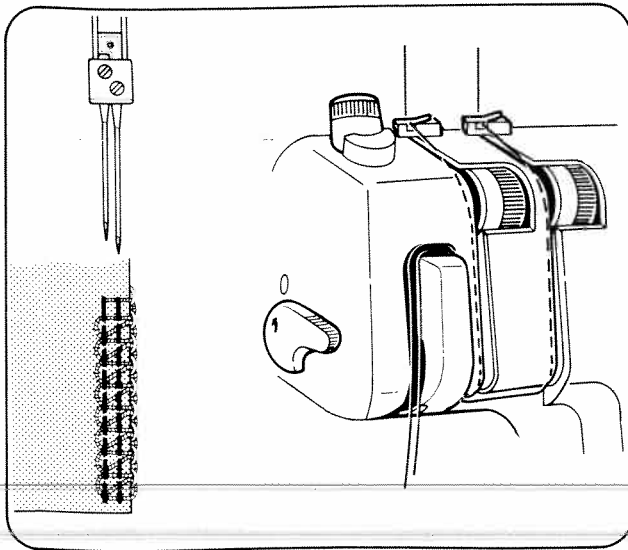

(1) By removing the right needle.

Three-thread overlock stitch using 1 needle for as wide as a 4-thread overlock stitch using 2 needles can be achieved.

Use the left thread tension. (Dial ①). The cutting width is normally 6mm.

The differential feed ratio is normally "N". (See P.16).

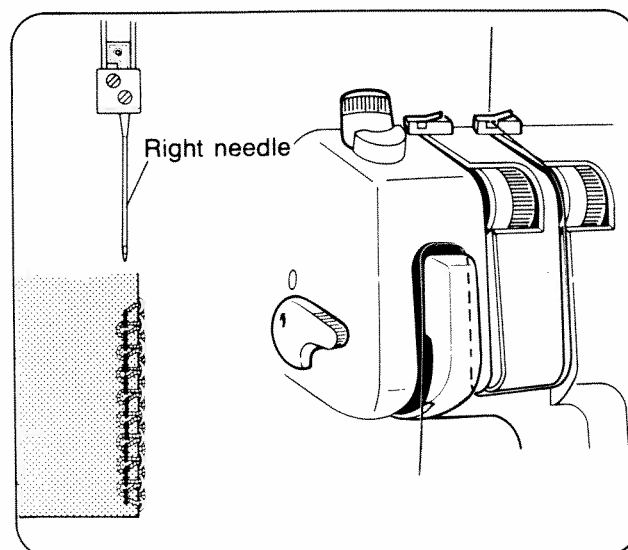

(2) By removing the left needle.

The right needle sews with a narrow width. Use the right thread tension (Dial ②). The cutting width is normally 4mm.

The differential feed ratio is normally "N". (See P.16).

11. ROLLED EDGE

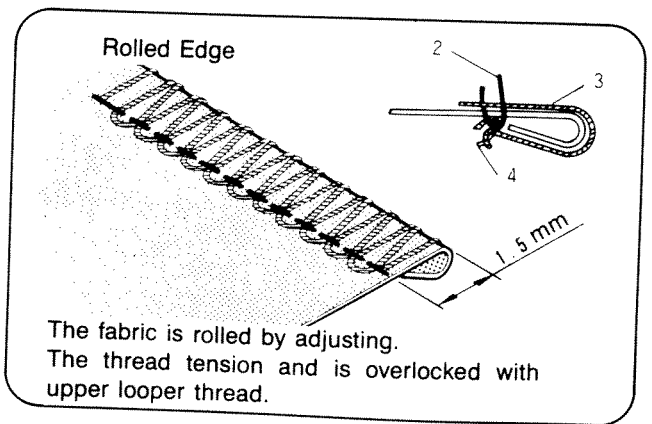
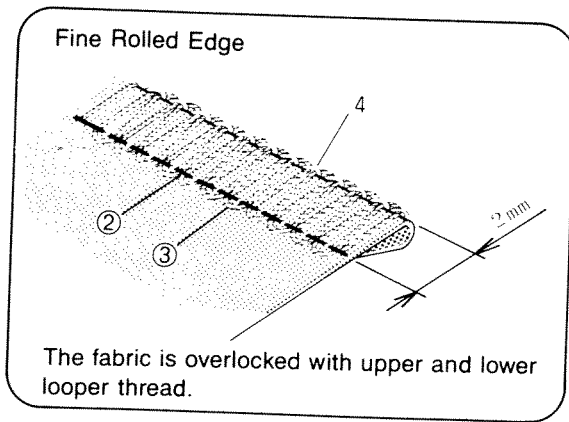

Rolled edge is achieved by rolling the fabric and overlocking, the 2 types as illustrated above are ideal for use with thin materials.

- (1) Remove the left needle. (Sew only with the right needle)
- (2) Pull stitch finger knob toward you to align it with front red line on needle plate.

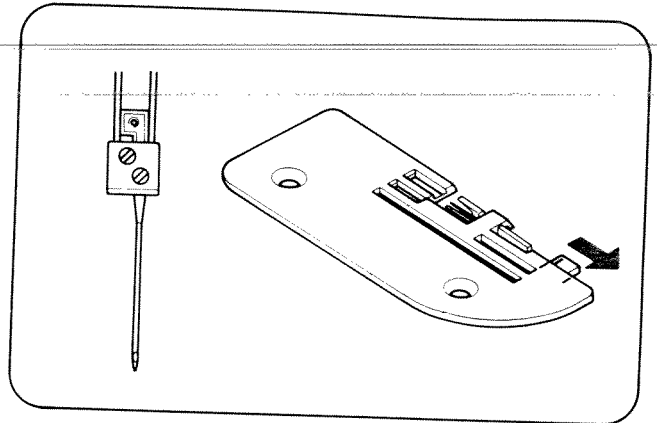

STANDARD CHART FOR ROLLED EDGE

		ROLLED EDGE	FINE ROLLED EDGE
CUTTING WIDTH		5-6 mm	5-6 mm
STITCH LENGTH		1-1.5 mm	1-1.5 mm
DIFFERENTIAL FEED RATIO		N	N
THREAD TENSION	NEEDLE THREAD	3-5	3-5
	UPPER LOOPER THREAD	3-5	3-5
	LOWER LOOPER THREAD	7-9	3-5

* Adjust as needed according to the kind of the fabric and the threads. (See P.24)

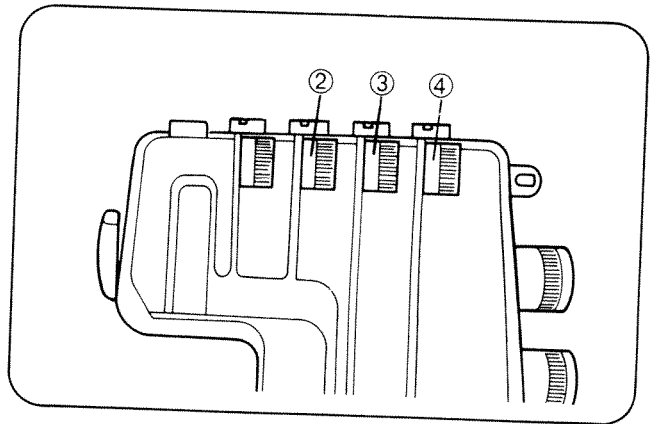

- (3) At the beginning of sewing, gently pull the end of the thread chain.

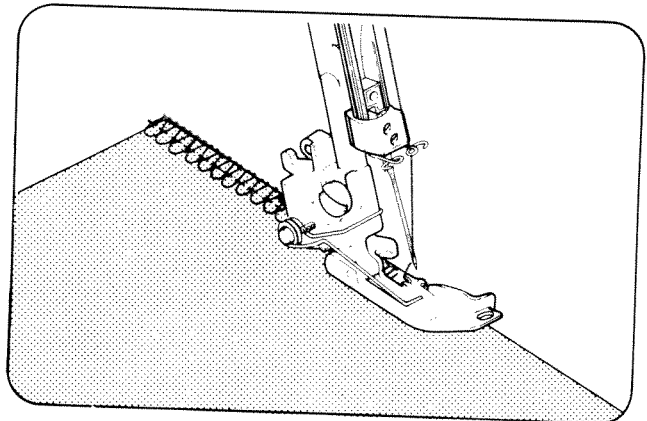

12. PIN TUCKS

Pin tucks are overlapped on the edge. So as to avoid cutting the fabric, raise the upper cutter. Pin tucking is suited to the design of a child's clothing and a lady's blouse.

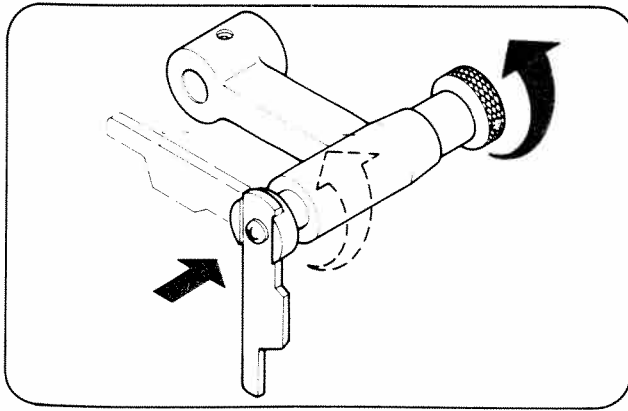

(1) Remove the left or right needle for your desired pintuck width. (Sew only with the one needle.)

(2) Raise the upper cutter. (See P.3)

* Raise the presser foot lifter.

(3) The tension is set for normal overlock. (See P.12)

* Mark and press pin tucks in advance.

* The differential feed ratio is normally "N".

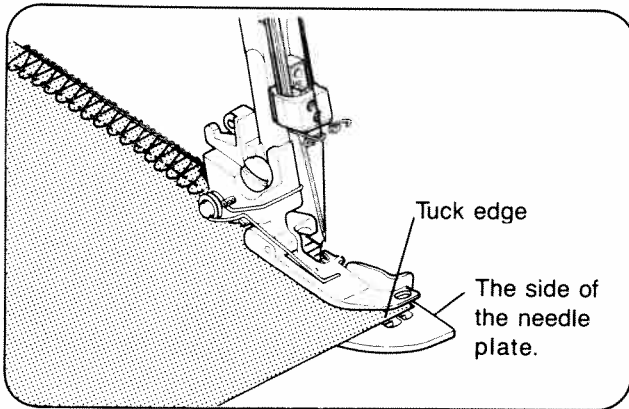
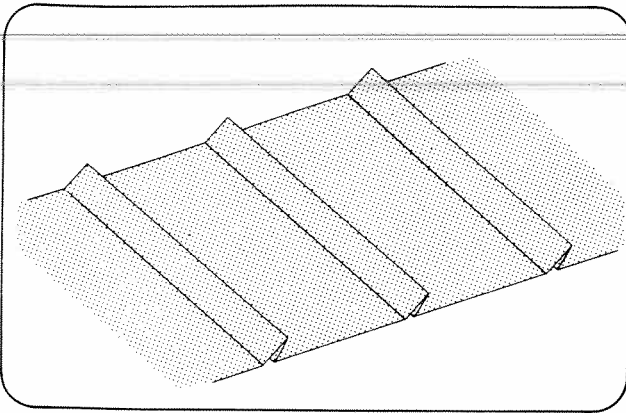

(4) Place the fabric under the presser foot with the edge in line with the side of the needle plate and start to sew.

* Make chain-stitch at the end of the sewing. (See P.11)

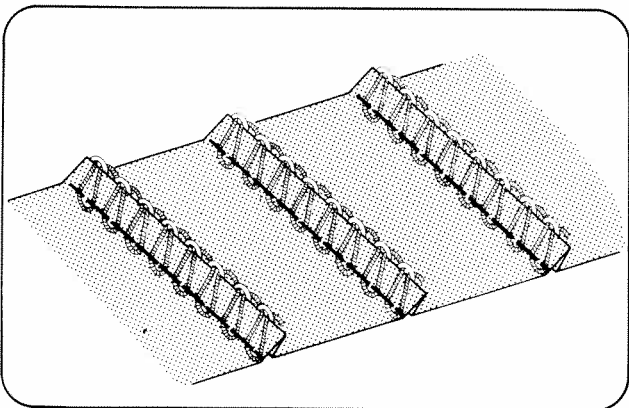

(5) The tuck is ironed to one side when your sewing is finished.

13. REPLACING LOWER CUTTER

Replacing Lower Cutter

✦ Unplug the machine

- (1) Open front cover and disengage upper cutter. (See page 3)
- (2) Loosen lower cutter clamp screw **a** and remove lower cutter.
- (3) Set the new lower cutter.
Align the top of lower cutter with the top of needle plate, and tighten lower cutter clamp screw **a**.

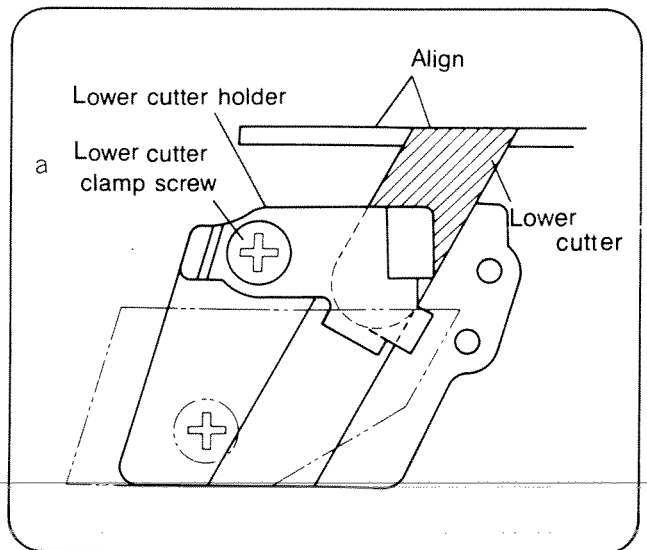

14. CHANGING LIGHT BULB

When the light does not come on even though it is switched on:

How to remove the lamp cover.

- (1) Take out the power supply plug.
- (2) Remove the presser foot lifter by pulling it out.
- (3) Remove the lamp cover.
- (4) Change the light bulb.
- (5) Replace the lamp cover.

How to use the bulb catcher (plastic sheath).

- (1) Take out the power supply plug.
- (2) Place the bulb catcher (plastic sheath) found in the accessory box around the bulb in the direction of arrow ①, turn it in the direction of arrow ②, and remove the bulb.
- (3) Replace the new bulb in the reverse steps of (2).

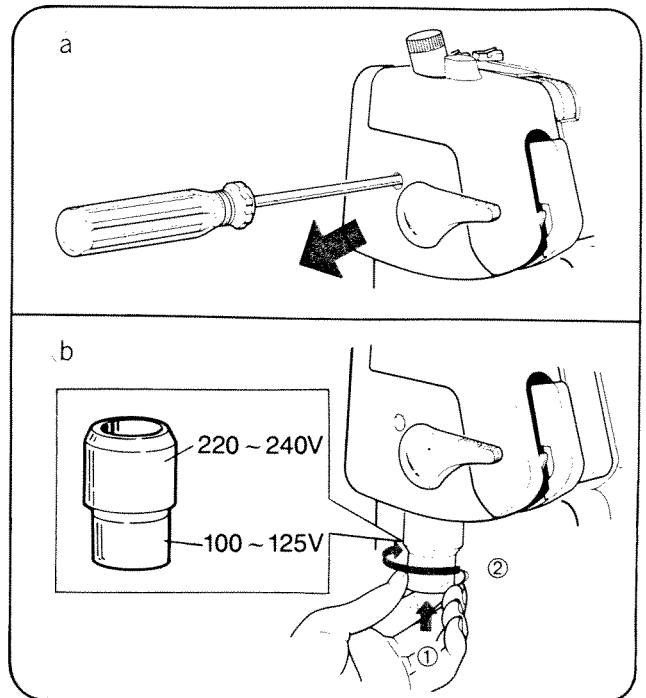

15. LUBRICATION

Although Lubrication is not required often for this machine since the important parts are all made of a special oil impregnated sintered metal, one or two drops of oil on moving metal parts will increase durability.

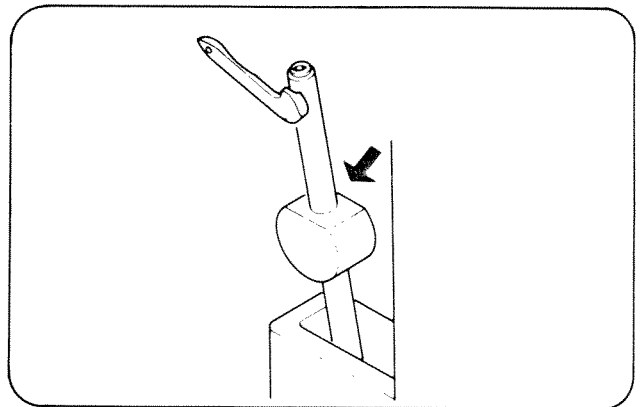

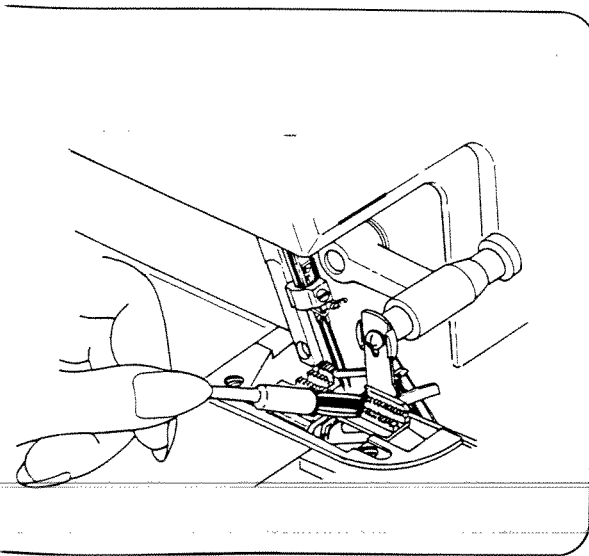

CLEANING

First disconnect machine from power supply by removing plug from the electric outlet.

1. Open front cover and side cover. (See Page 3)
2. Using the brush provided, remove all the dust and lint that has accumulated.



STORAGE

1. When the machine is not in use, please disconnect it from the power supply by removing plug from the electric outlet.
2. Using the vinyl cover provided please cover your machine when you finish your sewing.
3. Store away from bright and damp places.

SERVICING

Any questions regarding service and or operation are to be addressed to the store where the machine was purchased.

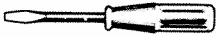
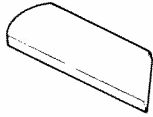
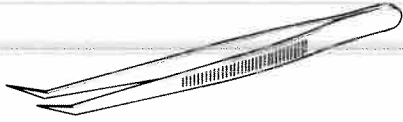
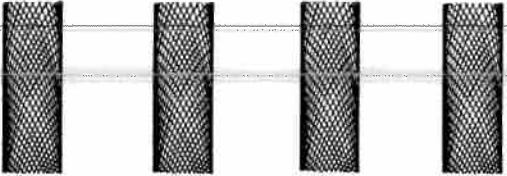
16. ACCESSORIES

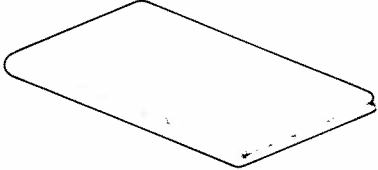
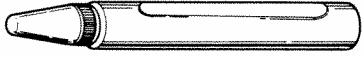
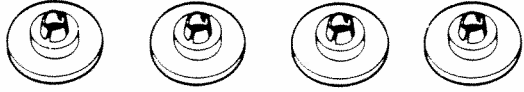
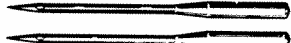
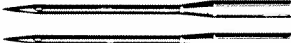
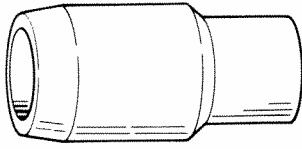
<p>Screw drivers</p> <p>(large) </p> <p>(small) </p>	<p>Lower cutter</p> 
<p>Tweezers</p> 	<p>Net (anti-spill sleeves)</p> 
<p>Cleaning brush</p> 	<p>Vinyl cover</p> 
<p>Oiler</p> 	<p>Spool Adapter</p> 
<p>Needles</p> <p>HA×1 (SCHMETZ 130/705H)  #11...2 (75)</p> <p> #14...3 (90)</p>	<p>plastic sheath</p> 

17. TABLE OF SEWING MATERIALS, NEEDLES AND THREADS

	Thin material (crepe, georgette)	Medium to thick material (Serge, gabardine, etc.)	Thick material (thick denim)
HA×1 Needle (SCHMETZ 130/705H) (For home-use sewing machine)	#11 (75)	#11 or #14 (75) or (90)	#14 (90)
Thread	Polyestel (spun, filament) #60/2 Twisted thread ~ #80/2 twisted thread (#80/3 Twisted thread ~ #100/3 twisted thread) (Three-thread overlock stitch)	#60/2 Twisted thread (Three or four-thread overlock stitch)	#50/2 Twisted thread ~ 60/2 twisted thread (Three or four-thread overlock stitch)
Thread tension (Needle thread)	Loose	Medium	Tight
Overedging width (Between left needle and edge)	5.2 ~ 5.5mm	5.2 ~ 5.5mm	5.5 ~ 6mm
Stitch length	2 ~ 2.5mm	2.5 ~ 3mm	2.5 ~ 3mm

Use ball point needles for Man-Made fibers or stretch fabrics.

18. PROBLEM SOLVING

Under normal conditions, if you carefully follow instruction for operating, no difficult or special adjustment is necessary for this machine.
Following cases are not failure of machine. Check your machine before you call for service.

PROBLEM	CAUSE	CORRECTION	REFERENCE PAGE
Machine does not sew	<ul style="list-style-type: none"> • Not plugged in properly 	<ul style="list-style-type: none"> • Plug cord into electrical outlet and machine properly 	4
Machine does not feed properly	<ul style="list-style-type: none"> • Pressure on presser foot insufficient • Differential feed not set correctly 	<ul style="list-style-type: none"> • Increase pressure by turning pressure regulator screw to right • Adjust differential feed 	11
Needle Breaks	<ul style="list-style-type: none"> • Bent or blunt needle • Needle inserted incorrectly • Pulling fabric while sewing 	<ul style="list-style-type: none"> • Insert new needle • Reset needle • Do not pull fabric 	6 6 -
Breaking Threads	<ul style="list-style-type: none"> • Improper threading • Thread tension(s) too tight • Incorrecto setting of needle 	<ul style="list-style-type: none"> • Re-thread machine • Reset thread tension(s) • Reset needle • Reset needle/change to new needle 	7~9 12 6
Skipping Stitches	<ul style="list-style-type: none"> • Bent or blunt needle • Needle inserted incorrectly • Improper threading 	<ul style="list-style-type: none"> • Insert new needle • Reset needle • Re-thread machine 	6 6 7~9
Irregular Stitches	<ul style="list-style-type: none"> • Tension not adjusted properly 	<ul style="list-style-type: none"> • Check thread tensions 	13.14
Puckering	<ul style="list-style-type: none"> • Needle thread tensions are too tight • Improper threading • Need drfferential feed 	<ul style="list-style-type: none"> • Loosen needle thread tensions • Re-thread machine • Set differential feed 0.7 - N 	13.14 7~9 16

19. SPECIFICATIONS

Number of threads	4 Threads (3 threads)
Number of needles	2 Needles (1 needle)
Needles	Standard HA×1 #11 ~ #14 (SCHMETZ 130/705H NO: 75 ~ 90)
Width between two needles	2mm
Overlock width	Standard 5.5 mm (Range 5.2 ~ 7 mm)
Stitch length	1 ~ 5 mm
Differential feed ratio	1: 0.7 ~ 2
Maximum sewing speed	1500 RPM
Machine dimensions	Width 300mm Depth 230mm (Max. 340mm) Height 290mm (Max. 350mm ~ 555mm)
Weight	8.7 kg

20. OPTIONAL ACCESSORY PRESSER FEET

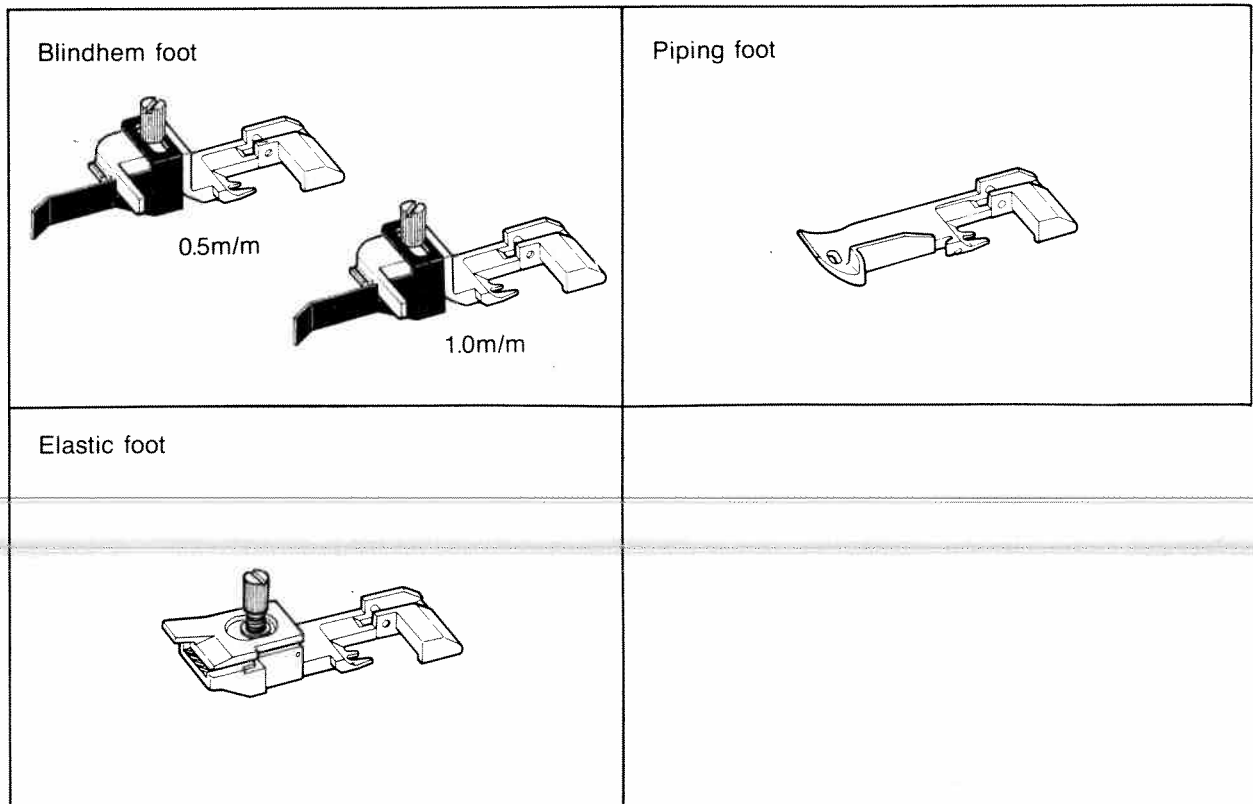

1670009-111-B-4