

LITTLE WONDER® Shredding

TruckLoader

Models 8221 and 8271

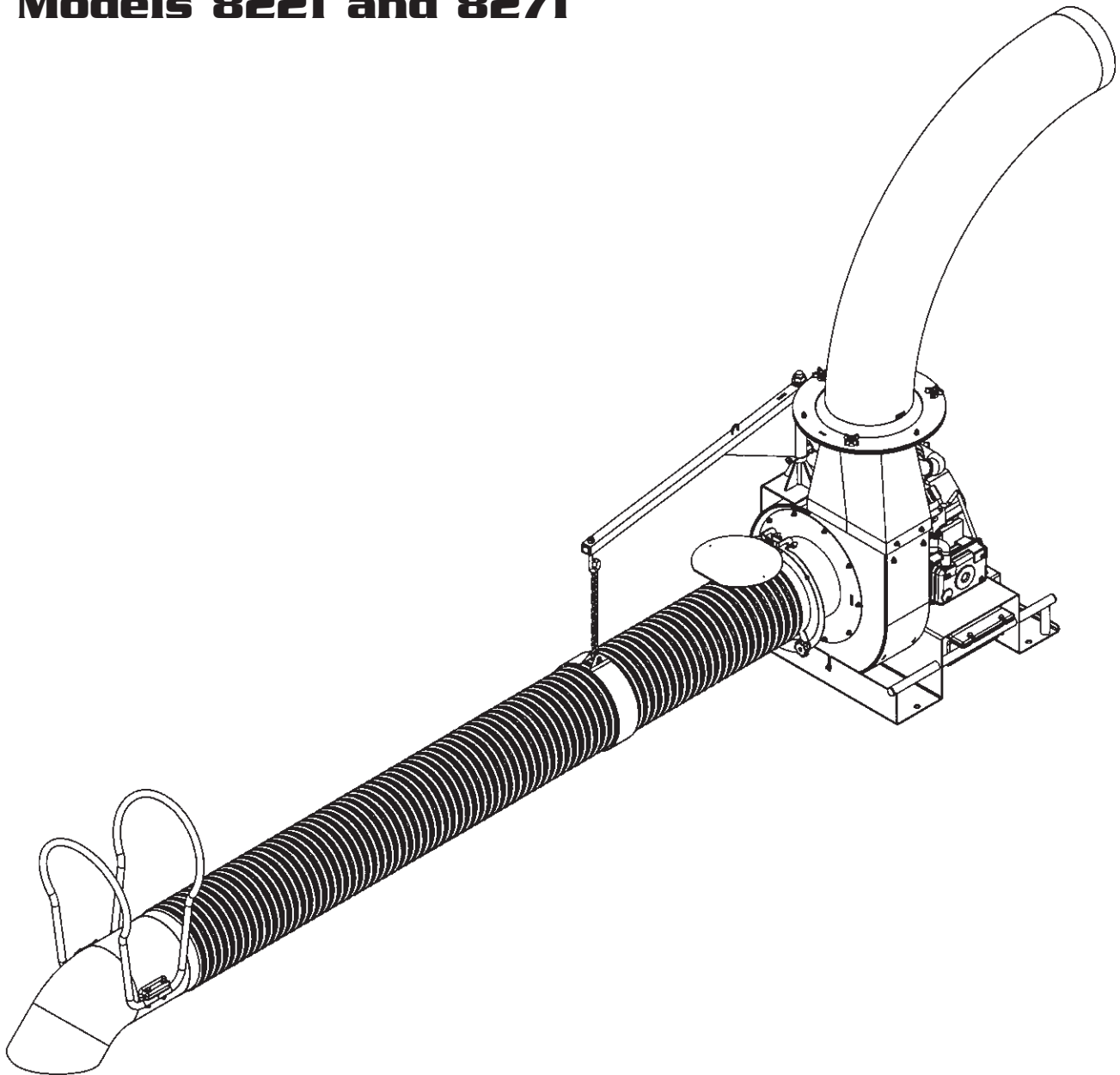

Table of Contents

Important Information

Introduction1
Service Information1
Special Safety Information1

Safety and Warnings

Safety Decals2

General Safety Rules

Warnings - "Don'ts"3
Warnings - "Do's"3-4
Engine/ Fuel Warnings - "Don'ts"4
Engine/ Fuel Warnings - "Do's"4

Assembly Instructions

Hose Assembly5
Mounting Shredding TruckLoader Frame5
Mounting Boom Arm to Housing Boom Column6
Mounting Discharge Chute to TruckLoader Housing6
Changing Direction of Discharge Chute7
Attaching Hose Assembly to Inlet Assembly7
Attaching Chain Loop Assembly to Boom Arm Assembly8
Attaching Hose Band to Chain Loop Assembly8
Adding Oil to Engine8
Filling Gas Tank8
Connecting Battery8
Discharge Extension Kit9

Operation

Starting the Engine9
Vacuuming9
Stopping the Engine9
Debris Blockage9
Re-filling the Gas Tank10

Transportation

Preparing TruckLoader Unit for Transportation10

Engine Oil and Fuel

Oil and Fuel Recommendations / Warnings10

Maintenance

Maintenance Schedule11
Removing and Replacing Fan and Talon Ring12
Liner Replacement13
Oil and Filter Change13
Heavy-Duty Air Cleaner14
Spark Plugs14

Storage

Preparing for Long-Term Storage15

Exploded Assembly Views and Part Numbers

Intake Hose and Discharge View15
Base Unit View16
Part Numbers17

Warranties

WarrantyBack cover

Important Information

A. Introduction

On behalf of everyone at **Little Wonder**, we would like to thank you for your purchase of a **Little Wonder** Shredding TruckLoader. This professional debris handling machine was designed to the highest standards to ensure many hours of uninterrupted service.

This manual provides the information necessary for safe and efficient operation and service. For your safety, it is critically important that you read and understand this entire manual before operating your Shredding TruckLoader.

Specifications:

Model	Dry Weight	Max Rpm
8221	500 lbs.	3600
8271	500 lbs.	3600

B. Service Information

Shredding TruckLoader Unit

Contact your local **Little Wonder** dealer.

Engine

Contact an authorized Kohler dealer. Dealers are listed in the Yellow Pages under "Lawn and Garden Equipment Supplies", "Lawn Maintenance" or "Lawn Mowers". Your dealer will need to know the model and serial number of your engine. For their location, please consult the owner's manual provided with your engine.

C. Special Safety Information

▲ WARNING ▲ DANGER ▲
**ATTENTION: THIS SYMBOL POINTS OUT
IMPORTANT SAFETY INSTRUCTIONS**
▲ WHEN YOU SEE THIS SYMBOL ▲
HEED ITS WARNING! STAY ALERT!

▲ WARNING ▲ DANGER ▲
**TO REDUCE THE POTENTIAL FOR ACCIDENTS,
COMPLY WITH THE SAFETY INSTRUCTIONS IN
THIS MANUAL. FAILURE TO COMPLY MAY RESULT
IN SERIOUS PERSONAL INJURY AND/OR
EQUIPMENT AND PROPERTY DAMAGE.**

▲ WARNING ▲ DANGER ▲
**THE ENGINE EXHAUST FROM THIS PRODUCT
CONTAINS CHEMICALS KNOWN TO THE STATE OF
CALIFORNIA TO CAUSE CANCER, BIRTH DEFECTS
OR OTHER REPRODUCTIVE HARM.**

Safety and Warnings

A. Safety Decals

In order to keep operators of the Shredding TruckLoader informed regarding safety and/or unit operation, decals (labels) have been placed on various parts of the unit. Adherence to the warnings and instructions depicted or otherwise conveyed in these decals is absolutely essential to the safe operation of the Shredding TruckLoader.

These decals (labels) must be replaced if they become illegible due to abrasion, etc.

It is your responsibility to replace the decals (labels) when they become hard to read. The location of these decals and their part numbers for ordering are shown on the picture below.

⚠ WARNING ⚠ DANGER ⚠

IMPROPER USE OR CARE OF THIS SHREDDING TRUCKLOADER, OR FAILURE TO WEAR PROPER PROTECTION CAN RESULT IN SERIOUS INJURY.

READ AND UNDERSTAND THE RULES FOR SAFE OPERATION AND ALL INSTRUCTIONS IN THIS MANUAL.

WEAR HEARING, EYE, AND BREATHING PROTECTION.

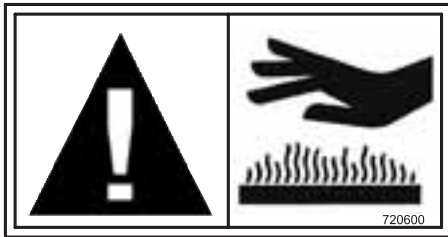

Caution: Hot Surface



P/N 720609

Caution: Thrown objects. Keep bystanders away.



P/N 600602
Warning Label

Keep hands and feet away from air discharge areas. Rotating fan will cause serious injury.

Caution: Thrown objects.

Keep bystanders away.

Always wear eye, ear and breathing protection.

Before performing any service or maintenance, disconnect spark plug wire. Make sure throttle is in STOP position.

Read and understand the Owners Manual. Store your Owners Manual in a safe place.

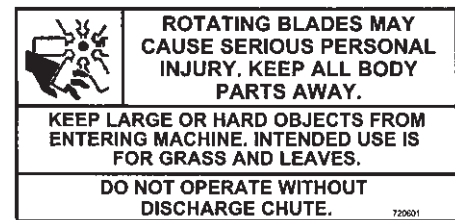
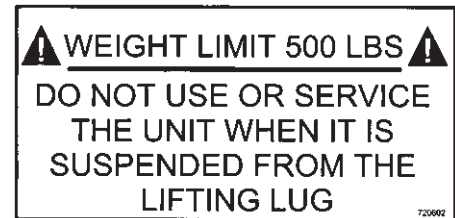

General Safety Rules

1. Read and understand manual.
2. Wear eye, hearing, and breathing protection, proper clothing and footwear.
3. While operating the machine, maintain a safe operating position, secure footing and good balance at all times.
4. Keep area clear of children, pets and bystanders.
5. Never attempt to use an incomplete machine or one fitted with an unauthorized modification.
6. Avoid contact with and inhalation of harmful fluids, gases, mists, fumes, and dust.
7. Check operation of the safety interlock switch daily. Do not defeat interlock system; it is for your protection.
8. Do not allow children to operate machine.
9. Do not override or remove any safety devices.

⚠ WARNING ⚠ DANGER ⚠

10. FAN COASTS AFTER THE ENGINE IS TURNED OFF.

⚠ WARNING ⚠ DANGER ⚠

11. ROTATING FAN. DON'T ATTEMPT TO REMOVE MATERIALS FROM INTAKE OR DISCHARGE WHEN UNIT IS RUNNING, OR FAN IS ROTATING.

⚠ WARNING ⚠ DANGER ⚠

12. DO NOT OPERATE UNIT IF EXCESSIVE VIBRATION OCCURS; SHUT ENGINE OFF IMMEDIATELY! REMOVE SPARK PLUG WIRES AND CHECK FOR DAMAGED IMPELLER, LOOSE IMPELLER BOLT, LOOSE IMPELLER KEY, OR LODGED FOREIGN OBJECTS.

13. Keep hands away from hose inlet and discharge chute.
14. Disconnect spark plugs before doing any cleaning or maintenance – There are two spark plugs on the machine. Disconnect both.
15. If the Shredding TruckLoader is mounted on a trailer, make sure that the driver of the towing vehicle has the operator of the Shredding TruckLoader in full view at all times.
16. When operating the Shredding TruckLoader, operator must stay to the side of the machine, never in front or behind
17. Wear gloves to protect your hands.
18. Beware that the machine is loud and during normal operation it may interfere with speech communication.
19. Check mounting hardware daily! Beware of the possibility that the machine may overturn, fall, or tip over because of unexpected movement of the vehicle.

⚠ WARNING ⚠ DANGER ⚠
DO NOT USE THE SHREDDING TRUCKLOADER IF THE MUFFLER IS DEFECTIVE OR MISSING.

A. ⚠ Warnings - "Don'ts"

Don't attempt to remove materials from intake or discharge when Shredding TruckLoader is running, or fan is rotating.

Don't install or remove components while Shredding TruckLoader is running. Turn off engine to make changeover. Be sure throttle is in the "slow" position, ignition key is in the "off" position and the Shredding TruckLoader has come to a complete stop. Remove the spark plug wires from the spark plug before removing material.

Don't point the Shredding TruckLoader discharge chute in the direction of people, cars, glass or anything that could be injured or damaged by blown debris.

Don't attempt to repair Shredding TruckLoader. Have repairs made by a qualified Little Wonder dealer or repairman. See that only Little Wonder and recommended engine manufacturer replacement parts are used.

⚠ WARNING ⚠ DANGER ⚠

DO NOT SMOKE WHEN FILLING FUEL TANK

Don't leave the engine running while the Shredding TruckLoader is unattended.

Don't store, spill, or use gasoline near flames or spark

B. ⚠ Warnings - "Do's"

Always dress properly. Do not wear loose clothing or jewelry. They can be caught in moving parts. Use of sturdy gloves, non-skid footwear and safety glasses are recommended. Always wear ear protectors where possible. Use respirator mask to avoid breathing dust.

Always stay alert. Watch what you are doing and use common sense. Do not operate Shredding TruckLoader when fatigued.

Always keep hands away from air intake and air discharge chute.

Always maintain and examine Shredding TruckLoader with care. Follow maintenance instructions given in unit and engine manuals.

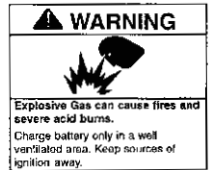

Explosive Gas!
Batteries produce explosive hydrogen gas while being charged. To prevent a fire or explosion, charge batteries only in well ventilated areas. Keep sparks, open flames, and other sources of ignition away from the battery at all times. Keep batteries out of the reach of children. Remove all jewelry when servicing batteries.

Before disconnecting the negative (-) ground cable, make sure all switches are OFF. If ON, a spark will occur at the ground cable terminal which could cause an explosion if hydrogen gas or gasoline vapors are present.

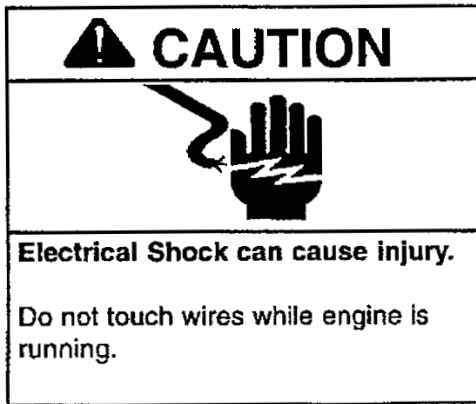

Electrical Shock!

Never touch electrical wires or components while the engine is running. They can be sources of electrical shock.

B. ⚠ Warnings - "Do's" Con't.

Always store Shredding TruckLoader indoors. When not in use, store Shredding TruckLoader indoors in a sheltered area (a dry place) where it is not accessible to children. The Shredding TruckLoader, as well as fuel, should not be stored in a house. Keep throttle in the "slow" position and ignition key in the "off" position.

Always be sure Shredding TruckLoader is fully assembled. Never operate Shredding TruckLoader without all guards and deflectors in place. Ensure that all nuts, bolts and screws are installed and properly tightened.

Always keep the throttle in the "slow" position when not in use.

Always keep a safe distance between two or more operators when working together simultaneously.

⚠ WARNING ⚠ DANGER ⚠

IF THE SHREDDING TRUCKLOADER IS USED IMPROPERLY OR SAFETY PRECAUTIONS ARE NOT FOLLOWED, THE USER RISKS SERIOUS INJURY TO THEMSELVES AND OTHERS.

READ AND UNDERSTAND THE FOLLOWING BEFORE ATTEMPTING TO OPERATE THIS SHREDDING TRUCKLOADER.

C. ⚠ Engine/ Fuel Warnings - "Don'ts"

Don't fuel engine or check fuel while smoking or near an open flame or other ignition source. Stop engine and be sure it is cool before refueling.

Don't leave the engine running while the Shredding TruckLoader is unattended.

Don't transport the Shredding Truckloader while the engine is running.

Don't start, run this TruckLoader indoors, or in an improperly ventilated area as poisonous carbon monoxide and other gasses are emitted.

Don't run engine when electrical system causes spark outside the cylinder. During periodic checks of the spark plug, keep plug a safe distance from cylinder to avoid ignition of evaporated fuel from cylinder.

Don't check for spark with spark plug or plug wire removed and grounded. Use an approved tester. Sparks can ignite fumes.

Don't run engine when the odor of gasoline is present or other explosive conditions exist.

Don't operate the unit if gasoline is spilled. Clean up spill completely before starting engine.

Don't refuel indoors or in an improperly ventilated area.

Don't operate your Shredding TruckLoader if there is an accumulation of debris around the muffler, and cooling fins.

Don't touch hot mufflers, cylinders or cooling fins as contact may cause serious burns.

D. ⚠ Engine/ Fuel Warnings - "Do's"

Always use fresh gasoline.

Always handle fuel with care; it is highly flammable. Never add fuel to a machine with a running or hot engine. Do not inhale fuel fumes as they are toxic.

The use of spark arrestor mufflers is required by law in the state of California (Section 4442 of the California Public Resources Code), as well as in other states or municipalities. Federal laws apply on federal lands.

⚠ WARNING ⚠ DANGER ⚠

HANDLE FUEL WITH CARE. IT IS HIGHLY FLAMMABLE. FUELING A HOT ENGINE OR NEAR AN IGNITION SOURCE CAN CAUSE A FIRE AND RESULT IN SERIOUS PERSONAL INJURY AND/ OR PROPERTY DAMAGE.

Assembly Instructions:

A. Hose Assembly (Figure #1)

1. Remove the Hose from the box.
2. With the assistance of a second person, hold the hose at both ends and stretch it out as far as possible. This will maximize the hose length and open the internal diameter.
3. Insert the Hose Flange Assembly into one of the open ends as shown.
4. Using one of the Hose Clamps, secure the hose to the Hose Flange Assembly by wrapping the clamp around the hose portion covering the Hose Flange and tighten.
5. Insert the Intake Nozzle into the end of the hose opposite the hose flange as shown.
6. Using the second Hose Clamp, secure the hose to the Intake Nozzle by wrapping the clamp around the hose portion covering the Intake Nozzle and tighten.
7. Install the Intake Nozzle Handle as shown.
8. To secure the Intake Nozzle Handle to the Intake Nozzle, insert the (4) Bolts (720597) and (4) Nuts (720583) that have been provided for the installation.

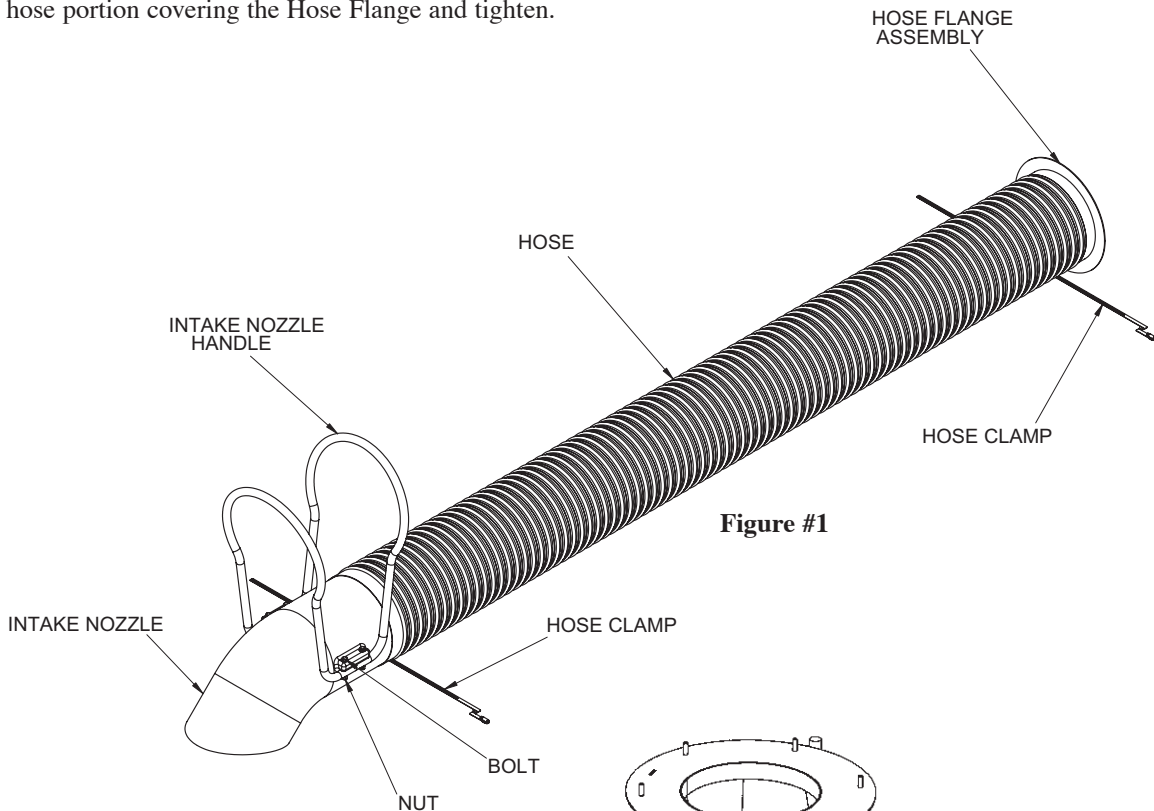

Figure #1

B. Mounting the Shredding TruckLoader Frame (Figure #2)

1. There are four holes in the TruckLoader frame deck through which the unit can be secured to an appropriate mounting surface. For your convenience, (4) Bolts (720599) and (4) Nuts (720560) have been provided for the installation.
2. For the purpose of lifting your unit, two options have been provided for you. The first option is a lifting lug found near the engine muffler mounted on the backside of the Housing Assembly. This lug has been designed to hold a maximum of 500 pounds. The second option is the lifting bars, which are incorporated in the frame and found on either side of the Housing Assembly.

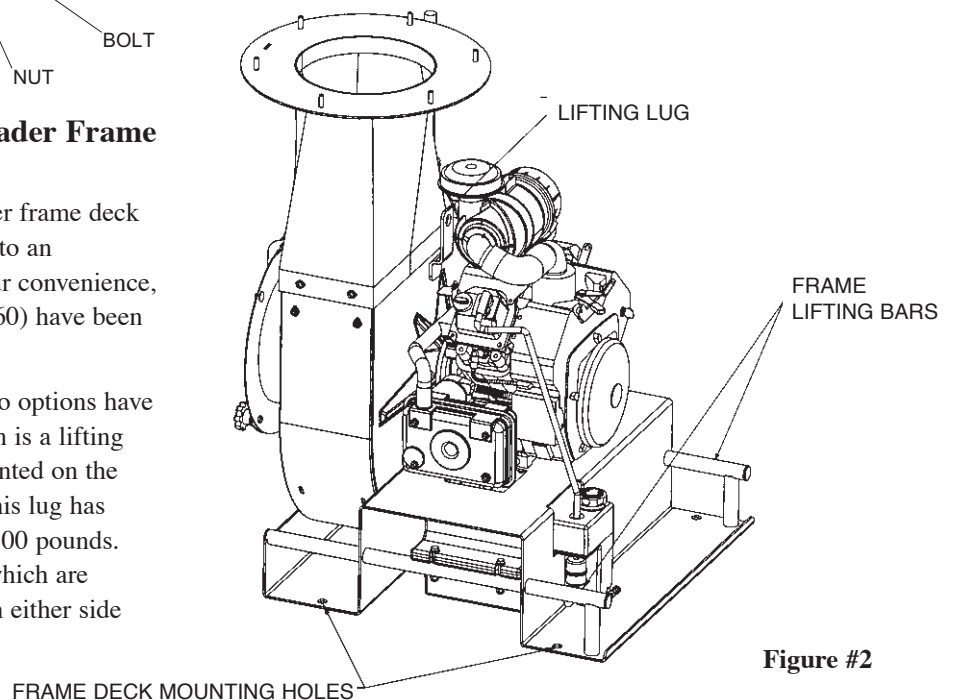

Figure #2

C. Mounting the Boom Arm Assembly to the Housing Boom Column (Figure #3)

1. Slide a Thrust Washer (720428) onto the shaft of the Boom Column Assembly.
2. Apply some #2 lithium based grease to the shaft of the Boom Column.
3. Install the Boom Arm Assembly (720406) onto the shaft of the Boom Column Assembly.
4. Slide a second Thrust Washer (720428) onto the shaft of the Boom Column Assembly.
5. Secure the Boom Arm Assembly and Washers to the shaft with a Lock Nut (720580).
6. As needed, insert some #2 lithium based grease through the grease fitting provided in the Boom Arm Assembly.
7. Install Linch Pin (720437) as shown.

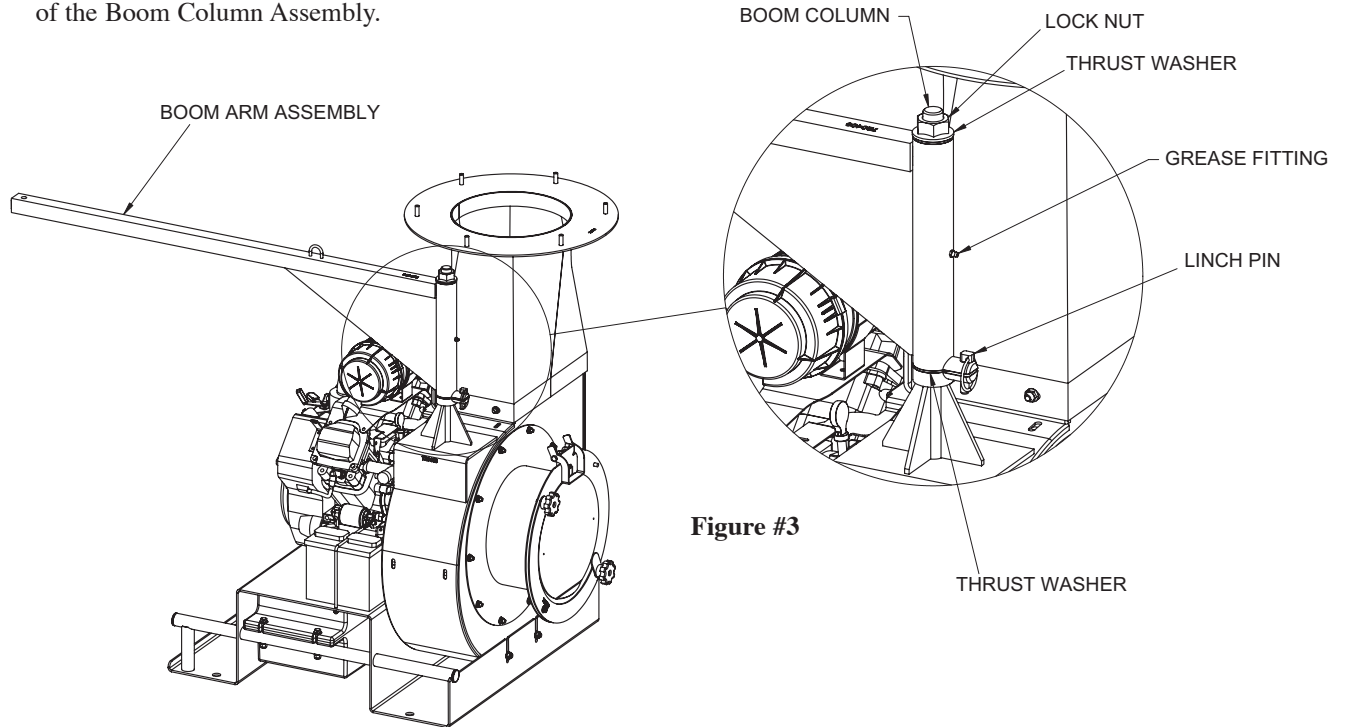

Figure #3

D. Mounting the Discharge Chute to the TruckLoader Housing (Figure #4)

1. Slide the Discharge Clamp Ring (720412) over the Discharge Chute and down onto its flange.
2. Lift the Discharge Chute's flange (720261) with the Discharge Clamp Ring (720412) and place on top of the Transition Discharge Tube's flange (720461) as shown.
3. Align the mounting holes of the Discharge Clamp Ring (720412) with the bolts on the Transition Discharge Tube's flange (720461).
4. Secure the Discharge Clamp Ring (720412) to the Transition Discharge Tube's flange (720461) by lightly fastening a Nut (720583) and Knob (720507) in an alternating pattern as three of each are provided.
5. Position the Discharge Chute into the receiver box of the transport vehicle and tighten down the Nuts and Knobs previously installed.

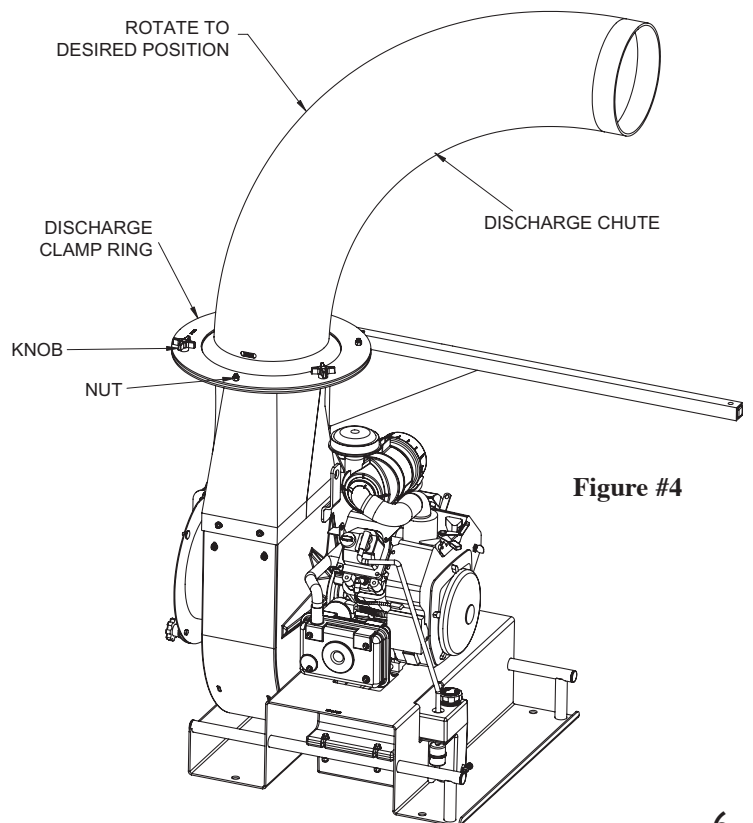

Figure #4

E. Changing the direction of the Discharge Chute (Figure #4)

1. Loosen the Knobs (720507) by hand and, if needed, the Nuts (720583) with a 1/2" wrench.
2. Rotate the Discharge Chute to the desired position.
3. Retighten the Knobs by hand and the Nuts, if loosened, with the 1/2" wrench.

F. Attaching the Hose Assembly to the Inlet Assembly (Figure #5)

1. Loosen the knob and rotate the Flapper Retainer (720257) to allow the Inlet Flapper to be lifted upward.
2. With the Inlet Flapper held upward, install the Hose Assembly by inserting the flange of the Hose Flange Assembly into the space (gap) between the face of the Inlet Assembly Flange and the back face Flange Retainer Plate as shown. The pin located in the upper right corner of the Inlet Assembly Flange will prevent the Hose Flange Assembly from sliding out of this pocket.

3. Since the Hose Assembly may be rotated 360 degrees, orient the Intake Nozzle to your preferred position and lock it in place.
4. To lock the Hose Assembly in place, tighten the two knobs attached to the Flange Retainer Plate and Flapper Retainer as shown. By tightening the knobs, it will push the flange of the Hose Flange Assembly against the flange of the Inlet Assembly and activate the Safety Switch Plate (720214). **THIS MUST BE DONE TO OPERATE THIS UNIT.**
5. When the Hose assembly is removed from the Inlet Assembly for unit transportation, the Inlet Flapper must be closed and the Flapper Retainer (720257) must be rotated to lock it in place.

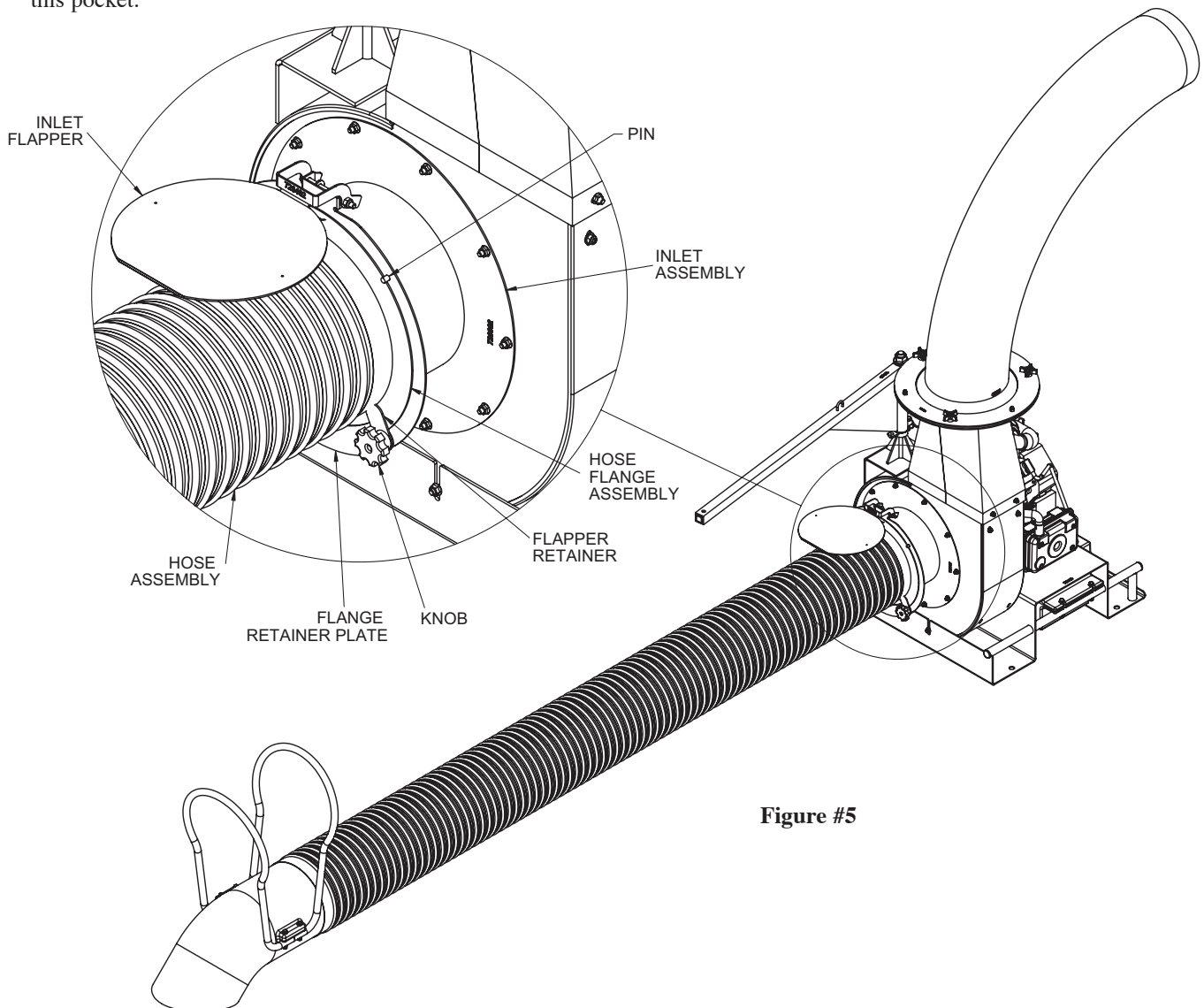
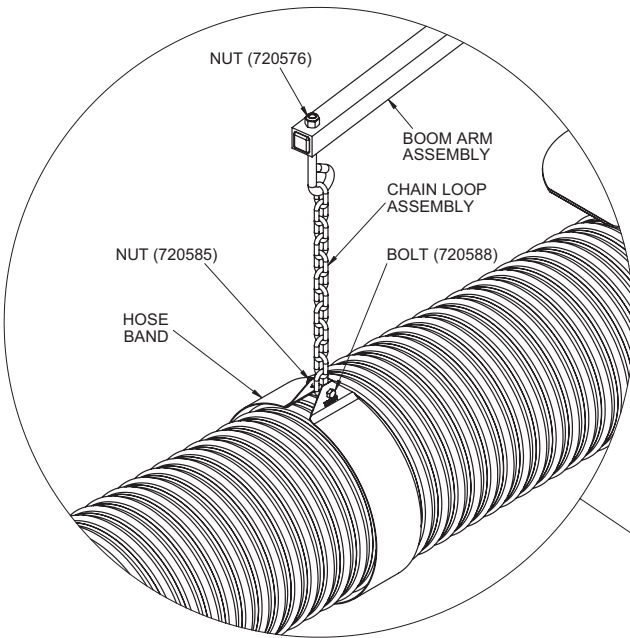

Figure #5

G. Attaching the Chain Loop Assembly to the Boom Arm Assembly (Figure #6)

1. Slip the threaded end of the Chain Loop Assembly (720290) through the hole found at the end of the Boom Arm Assembly (720406).
2. Once through, secure the Chain Loop Assembly with the Nut (720576).
3. The level position of the Hose Assembly to the Inlet Flange Assembly can be controlled by adjusting the position of the Nut on the thread of the Chain Loop Assembly.



H. Attaching the Hose Band to the Chain Loop Assembly (Figure #6)

1. After wrapping the Hose Band around the Hose, insert the Bolt (720588) through the holes in the Hose Band.
2. Once through, secure the Bolt in the Hose Band with the Nut (720585).
3. Attach the Hose Band to the Chain Loop Assembly by connecting the chain to the Bolt (720588) via the supplied Carabiner Quick Clip (720487)
4. Make sure the Hose Band is in the proper position with respect to the Hose to allow free movement with the Boom Arm Assembly.

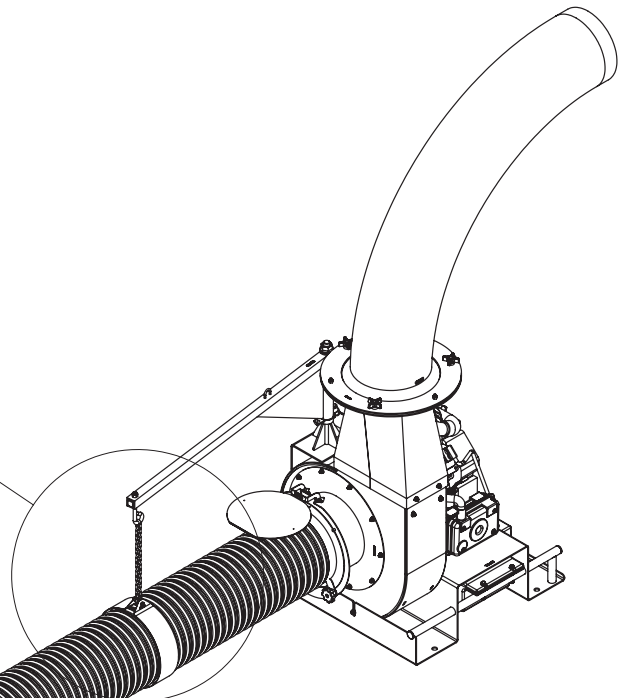

Figure #6

I. Adding Oil to the Engine

1. Fill the crankcase with the proper oil to the “F” mark found on the dipstick. The oil recommendations are found in the Engine Oil and Fuel section of this manual.

J. Filling the Gas Tank

1. Fill the tank with the proper fuel. Take extra caution when filling the tank not to over-fill it. The fuel recommendations are found in the Engine Oil and Fuel section of this manual.

K. Connecting the Battery

1. Connect the Red Battery Cable (720339) found connected to the engine starter to the positive terminal of the battery with the Bolt (720573) and Nut (720574) provided.
2. Connect the Black Battery Cable (720340) found connected to the engine block to the negative terminal of the battery with the Bolt (720573) and Nut (720574) provided.

L. Discharge Extension Kit Assembly Instructions

Contents Included in Kit:

1. Discharge Extension Hose (720436)
2. Hose Clamp (720388)

Tools Needed:

1. 9/16" Box Wrench or Socket Wrench w/ 9/16" Socket
2. Socket Wrench w/ 3/8" Socket or Flat Head Screw Driver
3. Utility Knife (if required)
4. Heavy Duty Wire Cutters (if required)

Disassembly and Assembly Instructions:

1. Turn off the TruckLoader and disconnect both of the spark plug wires from the engine.
2. Disassemble the TruckLoader Discharge Flapper by removing the knob, (2) nuts, (2) washers, and (3) bolts.
3. Remove the Discharge Flapper from the Discharge Nozzle.
4. Slide the Discharge Extension Hose over the end of the Discharge Nozzle where the Flapper has been removed. Make sure the Hose has overlapped the Discharge Nozzle by at least 6 inches.
5. Secure the attachment of the Discharge Extension Hose to the Discharge Nozzle with the supplied Hose Clamp. When installing the Hose Clamp, make sure it is positioned between the 1st and 2nd coil of the Discharge Extension Hose. Once in position, tighten the clamp to ensure a firm connection of the two parts.
6. Insert the opposite end of the Discharge Extension Hose into the receiver box on your truck. In the event the Hose is too long for your application, you can choose to cut it to a shorter length. If you shorten the length of this hose, make sure enough hose is left to properly install and secure it into the truck.
7. Once the Hose is properly fit into your truck, secure it in place with a rope, bungee cord, etc., as required to secure it in place.
8. Make sure the Discharge Nozzle and Discharge Extension Hose is positioned to ensure a straight flow from the TruckLoader into your receiver box.
9. Once everything has been properly positioned and secured, reconnect both spark plug wires on your engine.

Maintenance and Operation:

1. Be sure to check the positioning and all connections of your TruckLoader before starting.
2. To increase the life of your Discharge Extension Hose, periodically rotate the position of this hose. This can be accomplished by repeating the Assembly instructions specified above.

Operation:

A. Starting the Engine

1. Check the oil level. Add oil if necessary.
2. Check the air cleaner for dirty, loose, or damaged parts. Clean or replace parts as necessary.
3. Check the air intake and cooling area for dirt or debris and clean as necessary.
4. Move the choke control lever to the "choke" position.
5. Move the throttle control lever to the middle position.
6. Turn the ignition key clockwise to start the engine. As soon as the engine starts, release the key.
7. After letting the engine warm up, slowly move the choke lever to the "open" run position.
8. See the engine manual for additional information on starting.

B. Vacuuming

1. This machine has been designed for two methods of vacuuming debris.
 - With the handles of the Intake Nozzle in the operator's hands, move the Nozzle back and forth in a sweeping motion over the debris.
 - Rotate the Hose Assembly 90 degrees at the Inlet to allow the Intake Nozzle to lay sideways on the ground. By placing the Nozzle in this position, debris can be raked into the Nozzle by the operator.
2. While large amounts of debris can be vacuumed quickly with this machine, caution must be taken to avoid blocking the airflow into the Nozzle.
3. To increase the life of your Hose, periodically rotate the Intake Nozzle with respect to the Hose. This will allow the hose to wear more evenly.

C. Stopping the Engine

1. Move the throttle control lever to the "turtle" (slow) position.
2. Turn the key to the "off" position.

D. Debris Blockage

1. If a decrease in suction is experienced, there may be a debris blockage in the hose. To remove this blockage, simply grab the handles of the Intake Nozzle and stretch the hose out into a straight line with respect to the Inlet of the unit while the engine is at full throttle.
2. In the event the suction of the hose remains decreased after completing step #1, there may be a blockage in the housing. In order to inspect the unit for blockages, complete the following steps:

- a) Turn off the engine and wait until all moving parts have come to a complete stop.
 - b) Disconnect the spark plug wires from the spark plugs on the engine.
 - c) Remove the Hose Assembly from the Inlet Flange Assembly. With this removed, open the Inlet Flapper and remove any debris that is clogging the housing. **CAUTION SHOULD BE USED WHEN CLEARING DEBRIS FROM INSIDE THE HOUSING. GLOVES SHOULD BE WORN AS SHARP EDGES ON THE FAN, THE TALON RING, OR IN THE DEBRIS MAY BE PRESENT.**
 - d) Remove the Discharge Chute from the Transition Discharge Tube's flange. With the Chute removed, inspect the Transition Discharge part of the housing and remove any debris clogging this area. **CAUTION SHOULD BE USED WHEN CLEARING DEBRIS FROM INSIDE THE HOUSING. GLOVES SHOULD BE WORN AS SHARP EDGES ON THE FAN, THE TALON RING, OR IN THE DEBRIS MAY BE PRESENT.**
 - e) Inspect the Discharge Chute for debris and remove any debris clogging this area.
 - f) In order to re-assemble the removed parts, please refer to the Assembly Instructions found in this manual. After the unit is re-assembled, reconnect the spark plug wires and resume operation.
5. Make sure the Chain Loop Assembly cannot make contact with anything other than the Boom Arm Assembly. If necessary, use a bungee cord to secure it.
 6. Remove the Hose Assembly from the Inlet Flange Assembly.
 7. Close the Inlet Flapper and rotate the Flapper Retainer (720257) to allow the Flapper to be secured by tightening the knob.
 8. Remove the Discharge Nozzle from the TruckLoader Housing.
 9. Secure all the removed TruckLoader parts in the bed of the vehicle with the proper rope or hardware.
 10. Before moving a trailer containing the TruckLoader unit, be sure that everything is properly secured for road travel and that safety towing chains are properly attached to the vehicle.

Engine Oil and Fuel:

- A. Oil Recommendations: using the proper type and weight of oil in the crankcase is extremely important. It is also important to check oil daily and change oil regularly. Failure to use the correct oil, or using dirty oil, causes premature engine wear and failure.

1. Oil Type: Use high quality detergent oil of API (American Petroleum Institute) service class SG; SH, SJ or higher. Select the viscosity based on the air temperature at the time of operation as shown in the following table.

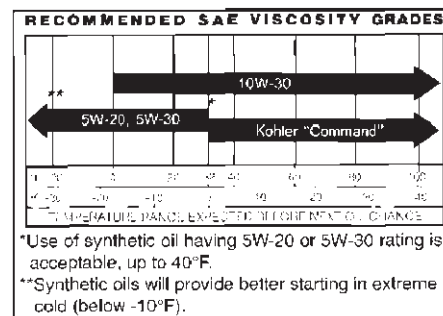

E. Re-filling the Gas Tank

1. If the unit was being operated, make sure the engine has been turned "off" and is allowed to cool off completely.
2. Once you have determined the engine is cool, fill the tank with the proper fuel. Take extra caution when filling the tank not to over-fill it. The fuel recommendations are found in the Engine Oil and Fuel section of this manual.

Transportation:

A. Preparing the TruckLoader Unit for Transportation

1. Make sure the engine is off.
2. Disconnect the Carabiner (720487) from the hose band.
3. Attach the Carabiner to the chain link closest to the Boom Arm Assembly.
4. Rotate the Boom Arm Assembly toward the vehicle to allow the locking bosses on the Arm and Column to line up. Once the bosses are aligned, insert the Linch

NOTE: Using other than service class SG, SH, SJ or higher oil or extending oil change intervals longer than recommended can cause engine damage. A logo or symbol on oil containers identifies the API service class and SAE viscosity grade.

B. Fuel Recommendations:

1. Fuel Type: For best results use only clean, fresh, unleaded gasoline with a pump sticker octane rating of 87 or higher. In countries using the Research method, it should be 90-octane minimum. Unleaded gasoline is recommended as it leaves less combustion chamber deposits and reduces harmful exhaust emissions.

Leaded gasoline is not recommended and must not be used on models where exhaust emissions are regulated.

- a. Gasoline/Alcohol blends: Gasohol (up to 10% ethyl alcohol, 90% unleaded gasoline by volume) is approved as a fuel for Kohler engines. Other gasoline/alcohol blends are not approved.
- b. Gasoline/Ether blends: Methyl Tertiary Butyl Ether (MTBE) and unleaded gasoline blends (up to a maximum of 15% MTBE by volume) are approved as a fuel for Kohler engines. Other gasoline/ether blends are not approved.

2. Fuel Warnings: Gasoline is extremely flammable and its vapors can explode if ignited. Store gasoline only in approved containers, in well-ventilated, unoccupied buildings, a way from sparks or flames. Do not fill the fuel tank while the engine is hot or running, since spilled fuel could ignite if it comes in contact with hot parts or sparks from ignition. Do not start the engine near spilled fuel. Never use gasoline as a cleaning agent.
 - a. To minimize gum deposits in fuel system and to insure easy starting, do not use gasoline left over from the previous season.
 - b. Do not add oil to the gasoline.
 - c. Do not overfill the fuel tank.
 - d. Filler neck should not contain fuel.

Maintenance Schedule:

FREQUENCY	MAINTENANCE REQUIRED
Daily or Before Starting the Engine	<ul style="list-style-type: none"> • Fill the fuel tank • Check the engine oil level and fill, if needed, to the proper level • Check the air cleaner for dirty, loose, or damaged parts • Check the air intake and cooling areas for debris and clean as necessary • Check the operation of the safety switch • Check for excessive vibration, loose, or damaged parts on the unit • Inspect and clean the Hose and Discharge Nozzle of clogging debris • Inspect the condition of all warning labels and replace if necessary
Every 5 hours of Usage	<ul style="list-style-type: none"> • Inspect for excessive vibration, loose, or damaged parts on the unit • Check the engine oil level and fill, if needed, to the proper level
Every 100 hours of Usage	<ul style="list-style-type: none"> • Change the engine oil as instructed in this manual • Remove the cooling shrouds of the engine and clean the cooling areas of dust, dirt, or debris
Every 200 hours of Usage	<ul style="list-style-type: none"> • Change the engine oil filter as instructed in this manual • Check the engine spark plugs condition and gap
Every 250 hours of Usage	<ul style="list-style-type: none"> • Service the engine's Heavy-Duty Air Cleaner, including replacing the Main Element, as instructed in this manual
Every 500 hours of Usage	<ul style="list-style-type: none"> • Service the engine's Heavy-Duty Air Cleaner, including replacing the Inner Element, as instructed in this manual

See the Kohler Engine Owner's Manual for additional required maintenance.

Maintenance:

A. Removing and Replacing the Fan and Talon Ring (Figure #7)

1. Disconnect the spark plug wires from the spark plugs on the engine.
2. Disconnect safety switch wire from engine.
3. Unbolt and Remove the Inlet Assembly from the face of the Housing.
4. Remove the bolt (720572) securing the Fan and Talon Ring to the crankshaft of the engine.
5. Pull the Talon Ring off the face of the Fan hub.
6. Rotate the Fan to allow the blades to align with the notches provided in the Housing face.
7. Thread a 3/4-16 x 5" long grade 5 (or better) bolt into the hub to jack or push the Fan from the crankshaft of the engine. (The Little Wonder #910505 jacking screw is recommended.) **Take note of the orientation of the fan with respect to the keyway upon removal. This is important when reinstalling the Fan.**
8. Upon removal of the Fan and Talon Ring, inspect for damaged or worn blades. If the Fan or Talon Ring is found to be damaged or excessively worn, it should be replaced with a new part.
9. Reinstall the Fan onto the crankshaft and orient it to the same position as removed in Step #6. Once the Fan is aligned properly with the keyways of the Fan hub and engine crankshaft in line, slide the Fan completely onto the crankshaft.
10. To reinstall the Talon Ring, align the "D" hole in the ring with the mating shape found on the Fan hub.
11. Using a new fan bolt (#720572) and adding a dab of Loctite 242 to it's threads, complete the installation of the Fan and Talon ring by securing the bolt with the proper torque into the engine crankshaft.
12. Install the Inlet Assembly to the face of the Housing and secure with the previously removed hardware.
13. Connect the spark plug wires to the spark plugs on the engine.

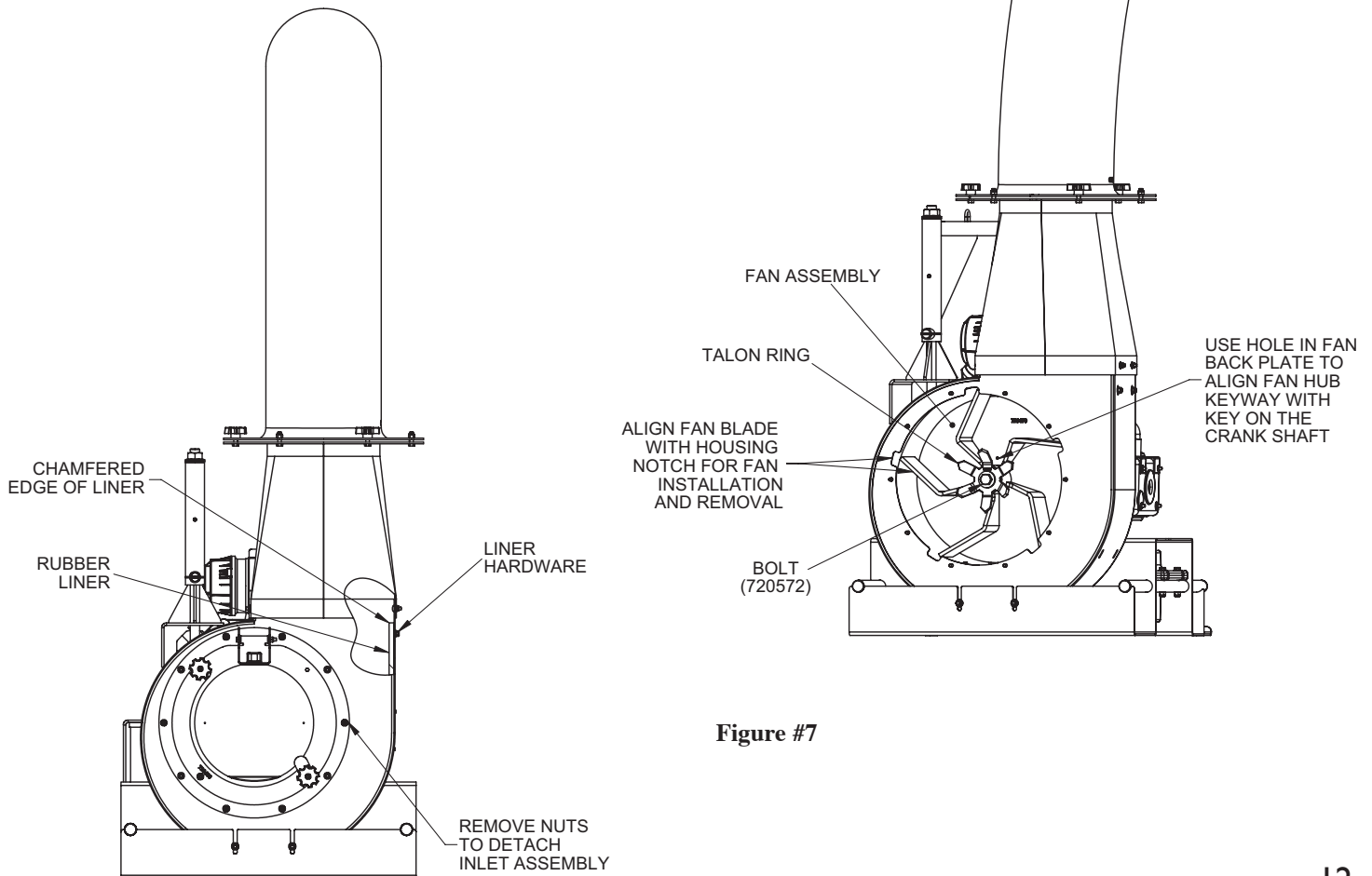

Figure #7

B. Liner Replacement (Figure #7)

1. Complete Steps 1 thru 7 found in section A (Removing and Replacing the Fan and Talon Ring).
2. Unbolt and remove the hardware securing the Liner to the Housing.
3. Remove the Liner from the housing by wrapping it and pulling it through the front of the housing.
4. When installing the new Liner into the Housing, make sure the chamfered edge of the liner is installed in the vertical position at the discharge opening of the housing.
5. As you position the Liner against the wall of the Housing, make sure the holes of the liner line up with the slots in the Housing.
6. Secure the Liner to the Housing (one hole at a time) with the 10 bolts, washers, and nuts. When installing the hardware, insert the bolts through the inside surface of the liner and install the washers and nuts to the outside face of the Housing.
7. Complete Steps 8 thru 13 found in section A (Removing and Replacing the Fan and Talon Ring).

C. Oil and Filter Change

1. Oil Change: Change oil after every **100 hours** of operation (more frequently under severe conditions). Refill with service class SG, SH, SJ or higher oil as specified in the “Viscosity Grades” above. Change the oil while the engine is still warm. The oil will flow more freely and carry away more impurities. Make sure the engine is level when filling, checking, and changing the oil. Change the oil as follows:
 - a) To keep dirt, debris, etc., out of the engine, clean the area around the oil fill cap/dipstick and drain valve before moving to the next step.
 - b) Attach a 1/2” I.D. hose to the fitting on the oil drain valve. Place the other end of the hose in an oil pan. Next, remove the oil fill cap and dipstick, then open the oil drain valve (counter-clockwise) to begin drainage. Be sure to allow ample time for complete drainage.
 - c) Once all the oil has drained, close the valve (clockwise) and remove the hose.
 - d) Fill the crankcase, with new oil of the proper type, to the “F” mark on the dipstick. Refer to “Oil Type” on page 11. Always check the level with the dipstick before adding more oil.
 - e) Reinstall the oil fill cap and tighten securely. Reinstall the dipstick. NOTE: To prevent extensive engine wear or damage, always maintain the proper oil level in the crankcase. Never operate the engine with the oil level below the “L” mark or over the “F” mark on the dipstick.
2. Oil Filter Change: Replace the oil filter at least every other oil change (every 200 hours of operation). Always use a genuine Kohler oil filter, Part No. 12 050 OI-S. Replace the oil filter as follows:
 - a) Follow steps A to C from the above “Change Oil” section.
 - b) Allow the oil filter to drain.
 - c) Before removing the oil filter, clean the area around the oil filter to keep dirt and debris out of the engine. Remove the old filter. Wipe off the surface where the oil filter mounts.
 - d) Place a new replacement filter in a shallow pan with the open end up. Pour new oil, of the proper type, in through the threaded center hole. Stop pouring when the oil reaches the bottom of the threads. Allow a minute or two for the oil to be absorbed by the filter material.
 - e) Put a drop of oil on your fingertip and wipe it on the rubber gasket.
 - f) Install the replacement oil filter to the filter adapter or oil cooler. Turn the oil filter clockwise until the rubber gasket contacts the filter adapter or oil cooler, then tighten the filter an additional 2/3 to 1 turn.
 - g) Follow steps 4-5 from above “Change Oil” section. Start the engine and check for oil leaks. Correct any leaks before placing the engine into service. Check oil level to be sure it is up to but not over the “F” mark.

D. Heavy-Duty Air Cleaner

1. Every **250 hours** of operation (more often under extremely dusty or dirty conditions), replace the main paper element and check inner element. Follow these steps.
 - a) Unhook the two retaining clips and remove the end cap from the air cleaner housing.
 - b) Pull the air cleaner element out of the housing. See **Removing Elements Figure**.
 - c) After the main element is removed, check the condition of the inner element. It should be replaced whenever it appears dirty, typically every other time the main element is replaced. Clean the area around the base of the inner element before removing it, so dirt does not get into the engine.

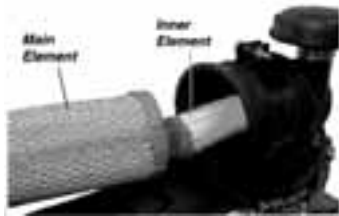

Removing Elements Figure



Heavy-Duty Air Cleaner Assembly Figure

- d) **Do not** wash the paper element and inner element or use pressurized air, this will damage the elements. Replace dirty, bent or damaged elements with new genuine Kohler elements as required. Handle new elements carefully; do not use if the sealing surfaces are bent or damaged.
- e) Check all parts for wear, cracks or damage. Replace any damaged components.
- f) Install the new inner element, Kohler Part No. **25 083 04-S** followed by the outer element, Kohler Part No. **25 083 01-S**. Slide each fully into place in the air cleaner housing.
- g) Reinstall the end cap so the dust ejector valve is down and secure with the two retaining clips. See **Heavy-Duty Air Cleaner Assembly Figure**.

E. Spark Plug

1. Every **200 hours** of operation, remove the spark plugs, check condition, and reset the gap or replace with new plugs as necessary. The standard spark plug is a Champion® RC12YC (Kohler Part No. 12 132 02-S). A high-performance spark plug, Champion® Premium Gold 2071 (used on Pro Series engines, Kohler Part No. 12 132 06-S) is also available. Equivalent alternate brand plugs can also be used.
 - a) Before removing the spark plug, clean the area around the base of the plug to keep dirt and debris out of the engine.
 - b) Remove the plug and check its condition. Replace the plug if worn or reuse is questionable. **NOTE:** Do not clean the spark plug in a machine using abrasive grit. Some grit could remain in the spark plug and enter the engine causing extensive wear and damage.
 - c) Check the gap using a wire feeler gauge. Adjust the gap to **0,76 mm (0.030 in.)** by carefully bending the ground electrode.
 - d) Reinstall the spark plug into the cylinder head. Torque the spark plug to **24.4-29J N-m (18-22 ft. lb.)**. 4. Reinstall the spark plug into the cylinder head. Torque the spark plug to **24.4-29J N-m(18-22 ft. lb.)**.

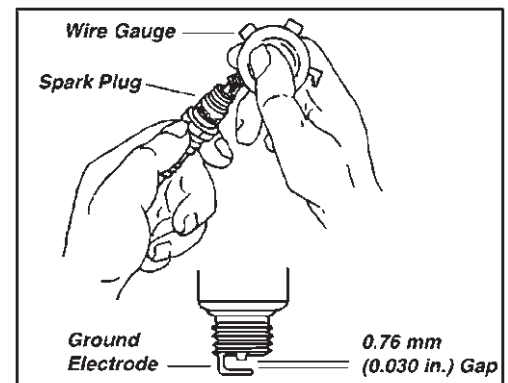

Storage:

A. Preparing for Long-Term (Two Months or More) Storage

1. Clean the exterior surfaces of the unit (including engine).
2. Change the Oil and Filter while the engine is still warm.
3. The fuel system must be completely emptied, or the gasoline must be treated with a stabilizer to prevent deterioration. To empty the fuel system, drain the fuel tank and carburetor or run the engine until the tank and system are empty. Drained fuel may only be stored for 30 days. If a stabilizer is chosen, follow the manufacturer's recommendation by adding the correct amount of additive for the amount of fuel to be stored. Fill the tank with this clean, fresh gasoline and run the engine for 2 to 3 minutes to get the stabilized fuel into the carburetor.
4. Remove the spark plugs and add one tablespoon of engine oil into each spark plug hole. Install plugs and ground spark plug leads-do not connect the leads to the plugs. Crank the engine two or three revolutions.
5. Store the unit and all of it's components in a clean, dry, well ventilated, non-child accessible, sheltered area that is out of sun light and high ambient temperatures.

Intake Hose and Discharge View

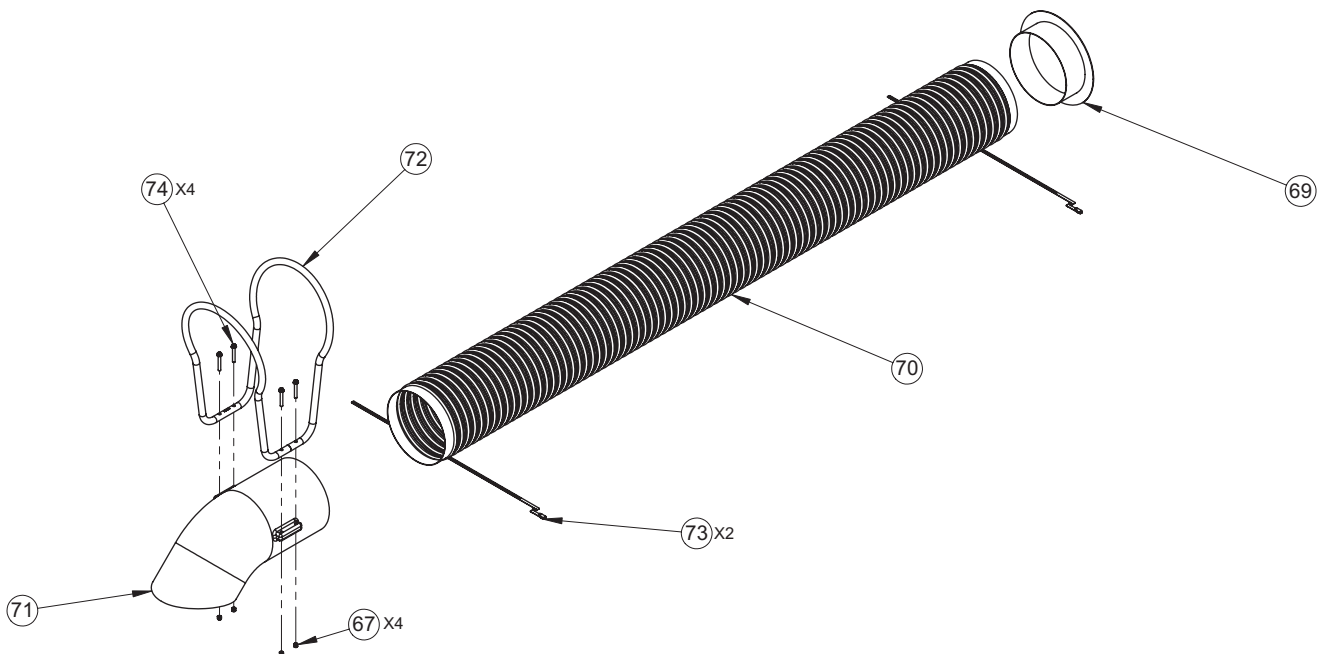
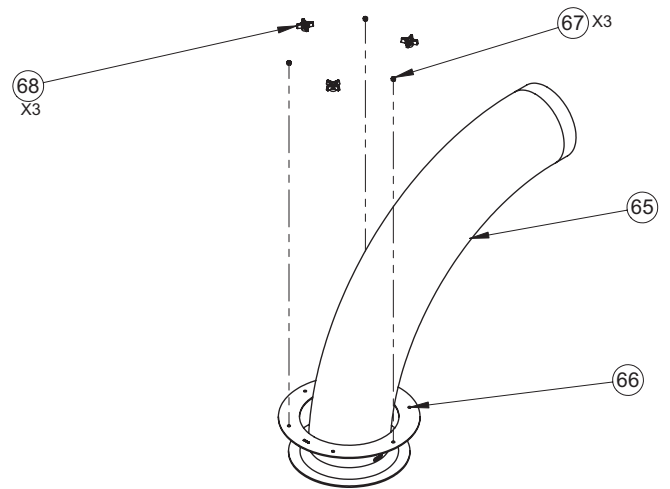

Base Unit View

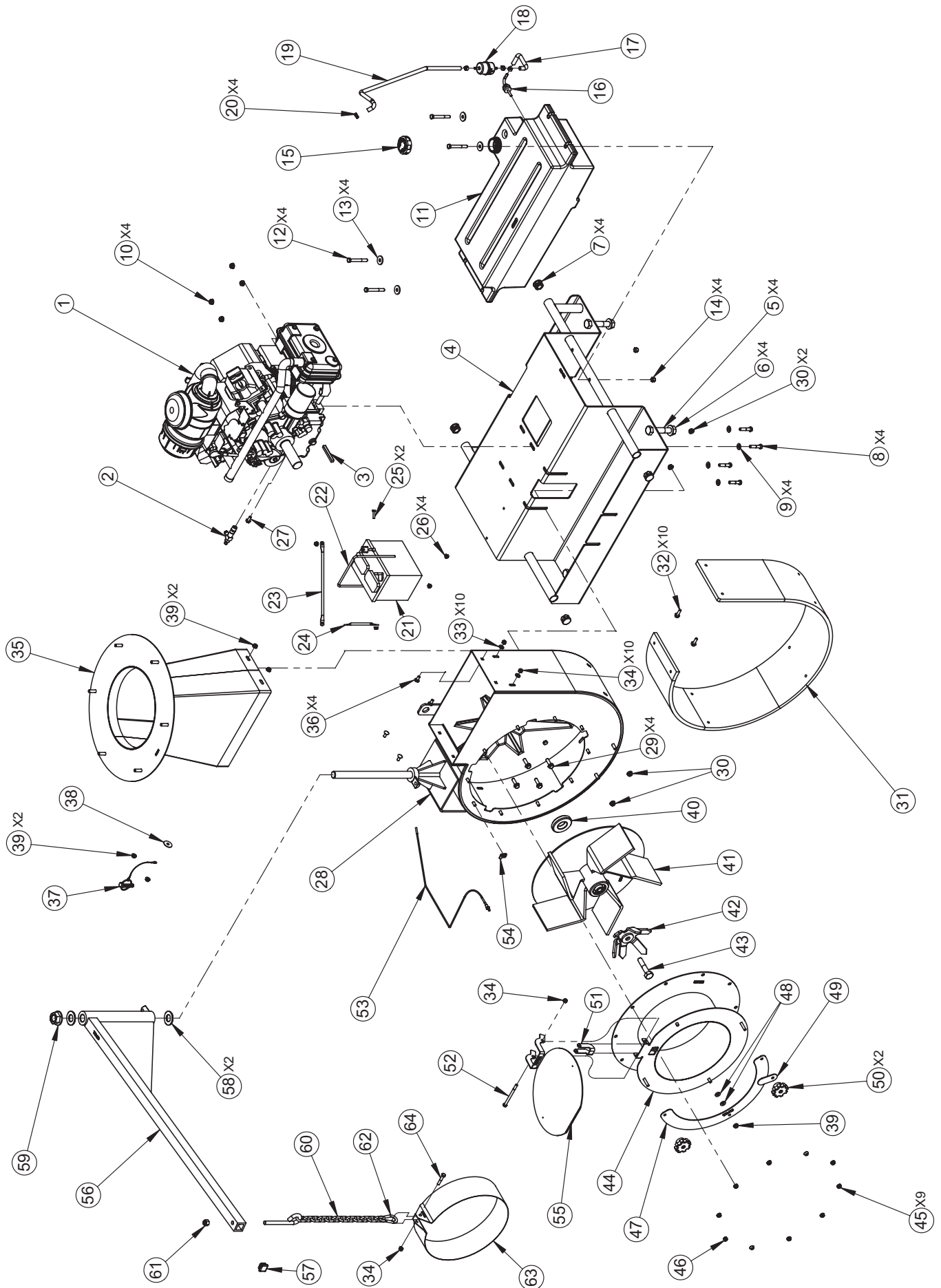

Model #8221 & 8271 Part Numbers

BALLOON ITEM #	PART #	DESCRIPTION	8221 QTY.	8271 QTY.
1	720903	22 HP KOHLER ENGINE	1	-
1	720904	27 HP KOHLER ENGINE	-	1
2	720483	OIL DRAIN VALVE	1	1
3	720466	3/8" SQ. x 3" LG KEY	1	1
4	720450	PAINTED SKID FRAME	1	1
5	720599	3/4-10 x 4" LG HEAVY HEX CAP SCREW	4	4
6	720560	3/4-10 GRADE G LOCK FLANGE NUT	4	4
7	720279	1-1/4" ROUND TUBE PLUG	4	4
8	720567	3/8" x 1-3/4" LG. GR 8 HEX BOLT	4	4
9	720582	3/8 SAE GRADE 8 FLAT WASHER	4	4
10	720594	3/8-16 WIZ NUT	4	4
11	720449	GAS TANK	1	1
12	721502	3/8" x 1-3/4" LG. GR 8 HEX BOLT	4	4
13	720503	3/8 SAE GRADE 8 FLAT WASHER	4	4
14	720518	3/8-16 NYLON INSERT NUT	4	4
15	720296	GAS TANK FUEL CAP	1	1
16	720484	GAS TANK OUTLET FITTING	1	1
17	720478	5" FUEL LINE HOSE	1	1
18	720480	KOHLER FUEL FILTER	1	1
19	720477	30" FUEL LINE HOSE	1	1
20	720298	FUEL LINE HOSE CLAMP	4	4
21	720299	HEAVY DUTY 12V BATTERY	1	1
22	720465	BATTERY HOLD DOWN	1	1
23	720469	BLACK BATTERY CABLE	1	1
24	720468	RED BATTERY CABLE	1	1
25	720573	1/4-20 x 1" LG. GR 8 HEAVY HEX CAP SCREW	2	2
26	720574	1/4-20 GRADE G LOCK FLANGE NUT	4	4
27	910503	BOLT, SERRATED FLANGE, 5/16-24 x 3/4" LG, LOCKING PATCH	1	1
28	720459	PAINTED HOUSING ASSEMBLY	1	1
29	720598	3/8-16 x 1-1/4" LG. GR 5 HEX BOLT	4	4
30	720562	3/8-16 GRADE F LOCK FLANGE NUT	4	4
31	720416	RUBBER LINER	1	1
32	720592	5/16-18" x 1" LG. GR 5 HEX BOLT	10	10
33	720584	5/16 SAE GRADE 8 FLAT WASHER	10	10
34	720585	5/16-18 NYLON INSERT NUT	12	12
35	720461	PAINTED TRANSITION DISCHARGE TUBE	1	1
36	720596	5/16-18 x 3/4" LG SQ. NECK CARRIAGE BOLT	4	4
37	720437	LINCH PIN w/ LAYNARD	1	1
38	721501	11/32" I.D. 1 1/4" O.D. WASHER	1	1
39	720586	5/16-18 GRADE G LOCK FLANGE NUT	5	5
40	720440	FAN HUB SPACER	1	1
41	720470	22HP BALANCED FAN ASSEMBLY	1	-
41	720472	27HP BALANCED FAN ASSEMBLY	-	1
42	720362	TALON RING ASSEMBLY	1	1
43	720572	5/8-18 x 3" LG. GR 8 HEAVY HEX CAP SCREW	1	1
44	720392	12" INLET ASSEMBLY	1	-
44	720393	14" INLET ASSEMBLY	-	1
45	114B	5/16-18 WIZ NUT	9	9
46	114C	NYLON INSERT LOCKNUT, 5/16-18 UNC	1	1
47	720400	12" HOSE FLANGE RETAINER PLATE	1	-
47	720401	14" HOSE FLANGE RETAINER PLATE	-	1
48	720509	5/16 WASHER	2	2

Model #8221 & 8271 Part Numbers

BALLOON ITEM #	PART #	DESCRIPTION	8221 QTY.	8271 QTY.
49	720257	FLAPPER RETAINER	1	1
50	154	5/16-18 FEMALE THREADED KNOB	2	2
51	720214	PAINTED SWITCH PLATE	1	1
52	720590	5/16-18 x 4" LG GRADE 8 BOLT	1	1
53	720408	SAFETY SWITCH WIRE ASSEMBLY	1	1
54	701312	CLIP WIRE HARNESS	1	1
55	720402	12" INLET FLAPPER	1	-
55	720403	14" INLET FLAPPER	-	1
56	720406	PAINTED BOOM ARM ASSEMBLY	1	1
57	720289	1-1/2" x 1/4" WALL SQUARE TUBE PLUG	1	1
58	720428	1" THRUST WASHER	2	2
59	720580	1-8 GRADE G LOCK FLANGE NUT	1	1
60	720290	CHAIN LOOP ASSEMBLY	1	1
61	720576	1/2-13 NYLON INSERT NUT	1	1
62	720487	CARABINER QUICK CLIP	1	1
63	720291	12" HOSE BAND	1	-
63	720292	14" HOSE BAND	-	1
64	720588	5/16-18 x 1-3/4" LG GRADE 8 BOLT	1	1
65	720261	DISCHARGE NOZZLE	1	1
66	720412	DISCHARGE CLAMP RING	1	1
67	720583	3/8-16 NYLON INSERT NUT (YELLOW ZINC)	7	7
68	720507	3/8-16 FEMALE THREADED KNOB	3	3
69	720404	12" HOSE FLANGE ASSEMBLY	1	-
69	720405	14" HOSE FLANGE ASSEMBLY	-	1
70	720485	12" DIA. x 7' LG INTAKE HOSE	1	-
70	720486	14" DIA. X 7' LG INTAKE HOSE	-	1
71	720264	12" PLASTIC INTAKE NOZZLE	1	-
71	720265	14" PLASTIC INTAKE NOZZLE	-	1
72	720266	12" PLASTIC INTAKE NOZZLE HANDLE	1	-
72	720267	14" PLASTIC INTAKE NOZZLE HANDLE	-	1
73	720388	12" HOSE CLAMP	2	-
73	720390	14" HOSE CLAMP	-	2
74	720597	3/8-16" x 2-3/4" LG. GR 5 HEX BOLT	4	4

1 YEAR LIMITED SERVICE & WARRANTY POLICY FOR SHREDDING TRUCKLOADER

The **Little Wonder** Shredding TruckLoader is guaranteed against defects in material and workmanship for a period of ONE YEAR from date of purchase, when used for RESIDENTIAL SERVICE, or COMMERCIAL SERVICE. Any **Little Wonder** Shredding TruckLoader or part found to be defective within the warranty period is to be returned to any registered Little Wonder Dealer.

Engines for all gasoline powered products are warranted separately by the engine manufacture for a period of a year. Therefore, there are no warranties made, expressed or implied, for engines for gasoline powered products by **Little Wonder**.

Transportation charges for parts and units submitted for replacement under this warranty must be borne by the purchaser.

THIS WARRANTY shall not be effective if the product has been subject to misuse, negligence or accident, or if the product has been repaired or altered outside of our Southampton factory in any respect which affects its condition or operation.

Little Wonder shall not be liable for any special indirect or consequential damages arising from defective equipment. Any implied warranty, including merchantability of fitness for a particular purpose, shall not extend beyond the written warranty period.

THIS WARRANTY shall only be effective if the enclosed Warranty/Registration card is properly filled out and returned to **Little Wonder**, Div. of Schiller-Pfeiffer, Inc. at time of purchase.

▲ WARNING ▲ DANGER ▲

THE ENGINE EXHAUST FROM THIS PRODUCT
CONTAINS CHEMICALS KNOWN TO THE STATE OF
CALIFORNIA TO CAUSE CANCER, BIRTH DEFECTS
OR OTHER REPRODUCTIVE HARM.

LITTLE WONDER®
DIVISION OF SCHILLER-PFEIFFER, INCORPORATED
1028 STREET ROAD, P.O. BOX 38
SOUTHAMPTON, PA 18966
PHONE 877-596-6337 • FAX 215-357-8045
877-LWONDER
www.littlewonder.com

P/N 720712
8/05