

## Instructions and Parts List

---

# 3M-Matic™

## 22A-S

Model 18900

## Adjustable Case Sealer

## with

## AccuGlide™

## SST

## Taping Heads

Model 18900

**IMPORTANT**  
It is recommended you immediately order the spare parts listed on page 19. These parts are expected to wear through normal use, and should be kept on hand to minimize production delays.

"3M-Matic" and "AccuGlide" are Trademarks of 3M, St. Paul, MN 55144-1000

34-7004-7460-3(A440.025)R1

©3M 1980

Litho in U.S.A.

---

### 3M Packaging Systems Division

3M Center Bldg. 220-8W-01  
St. Paul, MN 55144-1000



# Replacement Parts and Service Information

---

## To Our Customers:

**This is the 3M-Matic™/AccuGlide™/Scotch™ brand equipment you ordered. It has been set up and tested in the factory with "Scotch" brand tapes. If technical assistance or replacement parts are needed, call or Fax the appropriate number listed below.**

**Included with each machine is an Instructions and Parts List manual.**

### Technical Assistance:

3M-Matic™ Helpline – 1-800/328 1390. Please provide the customer support coordinator with the machine number, machine type/model and serial number. If you have a technical question that does not require an immediate response, you may Fax it to 715/381 0248.

### Replacement Parts and Additional Manuals

Order parts by part number, part description and quantity required. Also, when ordering parts and/or additional manuals, include machine name, number and type. A parts order form is provided at the back of this manual.

#### **3M/Tape Dispenser Parts**

**241 Venture Drive  
Amery, WI 54001-1325**

**1-800/344 9883  
FAX# 715/268 8153**

**Minimum billing on parts orders will be \$25.00. Replacement part prices available on request.**

**\$10.00 restocking charge per invoice on returned parts.**

**Note : Outside the U.S., contact the local 3M subsidiary for parts ordering information.**



**3M Packaging Systems Division  
3M Center, Building 220-8W-01  
St. Paul, MN 55144-1000**

"3M-Matic", "AccuGlide" and "Scotch" are trademarks of 3M, St. Paul, Minnesota 55144-1000  
Printed in U.S.A.  
© 3M 1999 44-0009-1851-4(E79.0)

**Instruction Manual**  
**22A-S Adjustable Case Sealer**  
**Model 18900**

<b>Table of Content</b>	<b>Page</b>
Description - - - - -	1
Receiving and Handling - - - - -	2
Warranty - - - - -	2
Specifications - - - - -	2 - 4
Set-Up Procedure - - - - -	5 - 11
Conveyor Bed Height - - - - -	6
Machine Leveling - - - - -	6
Electrical Connection - - - - -	7
Tape Loading - - - - -	7 - 9
Box Size Set-Up & Operation - - - - -	10 - 11
Adjustments - - - - -	12 - 15
Tape Web Alignment - - - - -	12
Applying Mechanism Spring - - - - -	12
One-way Tension Roller Assembly - - - - -	13
Box Drive Belts - - - - -	14 - 15
Maintenance - - - - -	16 - 18
Blade Replacement - - - - -	16
Replacing Box Drive Belts - - - - -	16
Cleaning of the Machine - - - - -	17
Cut-Off Blade - - - - -	17
Electrical Schematic - - - - -	17
Circuit Breaker - - - - -	17
Lubrication - - - - -	18
Blade Oiler Pad - - - - -	18
Suggested Spare Parts - - - - -	19
How To Order Replacement Parts - - - - -	19
Repair Service - - - - -	19
Attachments - - - - -	20
Replacement Parts Illustrations & Parts Lists - - - - -	21 - 22
Taping Head Assemblies - - - - -	21
Frame Assemblies - - - - -	22

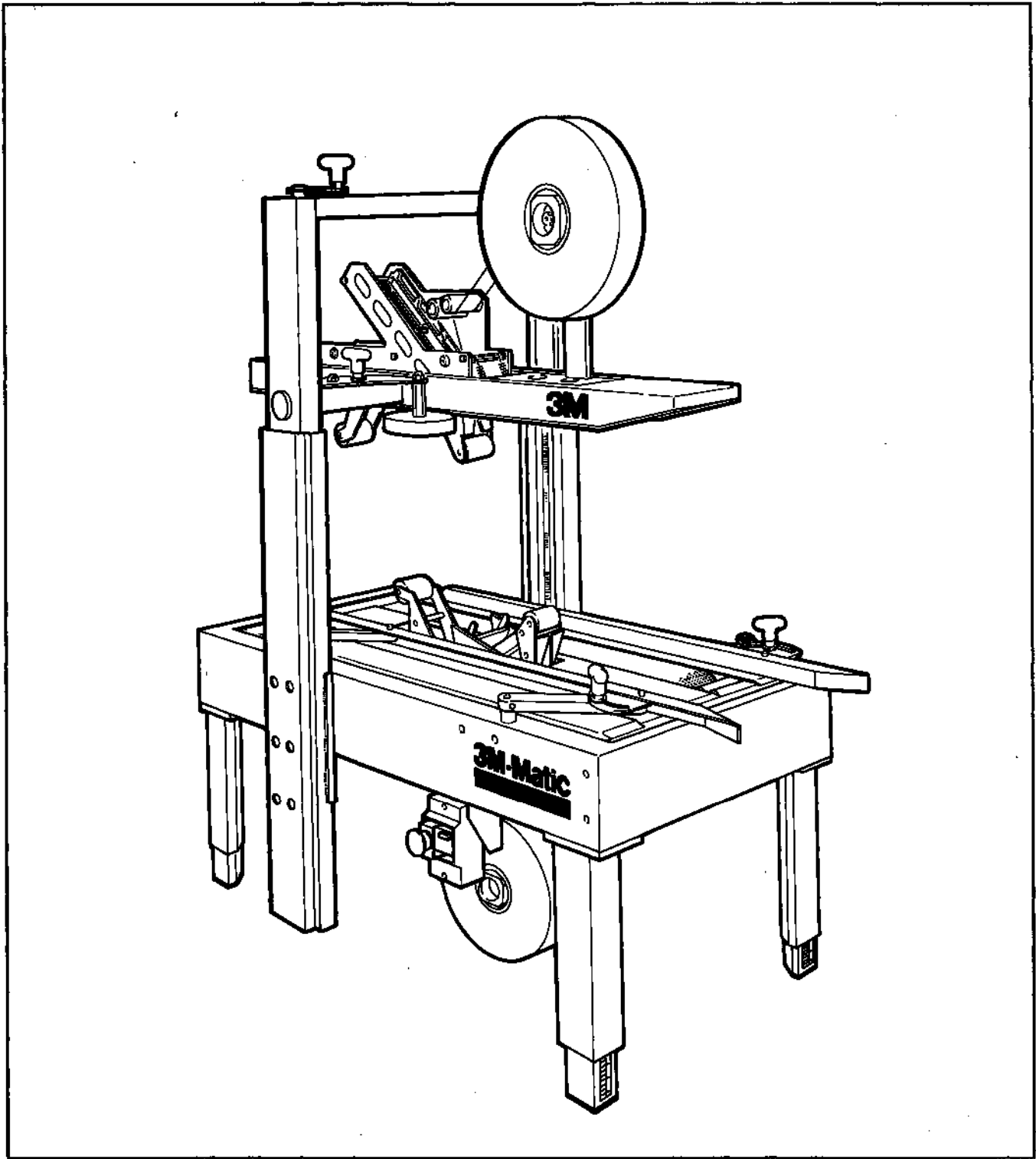

**"3M-Matic" 22A-S Adjustable Case Sealer - Model 18900**

**Description**

The "3M-Matic" 22A-S Adjustable Case Sealer with "AccuGlide" SST Taping Heads is designed to apply a "C" clip of "Scotch" brand Pressure-sensitive Film Box Sealing Tape to the top and bottom center seam of regular slotted containers. The 22A-S is manually adjustable to a wide range of box sizes (see box size specifications).

## Receiving And Handling

After the machine has been uncrated, examine the 22A-S Case Sealer for damage that might have occurred during transit. If damage is evident, file a damage claim immediately with the transportation company and also your 3M Representative. Several machine components are tied down to prevent damage during transit. Remove these before proceeding with following set-up instructions.

## Warranty

**IMPORTANT NOTICE TO PURCHASER:** The following is made in lieu of all warranties, expressed or implied, including the implied warranties of merchantability and fitness for purpose: Seller and manufacturer warrant that the "3M-Matic" equipment is free from defects in material and workmanship on the date the machine is shipped by the seller and for the time periods stated below. Seller's and manufacturer's only obligation hereunder shall be to repair or replace, at its option, any mechanical part proved to be defective, provided the defect occurs within ninety (90) days\* (see NOTE below) after the date of delivery and the said part is returned immediately to the 3M factory or to an authorized service station designated by the manufacturer. Neither seller nor manufacturer shall be liable either in tort or in contract for any loss or damage, direct, incidental, or consequential, arising out of the use of or the inability to use the "3M-Matic" equipment. No statement or recommendation not contained herein shall have any force or effect unless in an agreement signed by officers of seller and manufacturer.

**NOTE:** \* The time period shall be one (1) year for the transmission and motor, three (3) years for the "AccuGlide" taping head, except for the blades, springs and apply/buffing rollers which shall remain subject to the ninety (90) day warranty period.

"Scotch", "3M-Matic" and "AccuGlide" are trademarks of 3M, St. Paul, Minnesota 55144-1000.

## Specifications

### 1. Power Requirements:

Electrical - 115 VAC, 60 Hz, 2.8A for Coel motor.

The machine is equipped with a standard neoprene covered power cord and a grounded plug. Contact your 3M Representative for power requirements not listed above.

### 2. Machine Dimensions:

#### Overall Dimensions

Length	-	42 1/2 inches [1,080 m]
Width	-	27 1/2 inches [0,700 m]
Height	-	56 5/8 inches [1,440 m]
Conveyor Bed Height (without casters)	-	Adjustable from 20 1/2 inches [520 mm] to 31 1/2 inches [800 mm]
Weight	-	300 pounds [137 kg] crated 240 pounds [110 kg] uncrated

(Specifications continued on next page.)

Specifications (Continued)

3. Operating Rate:

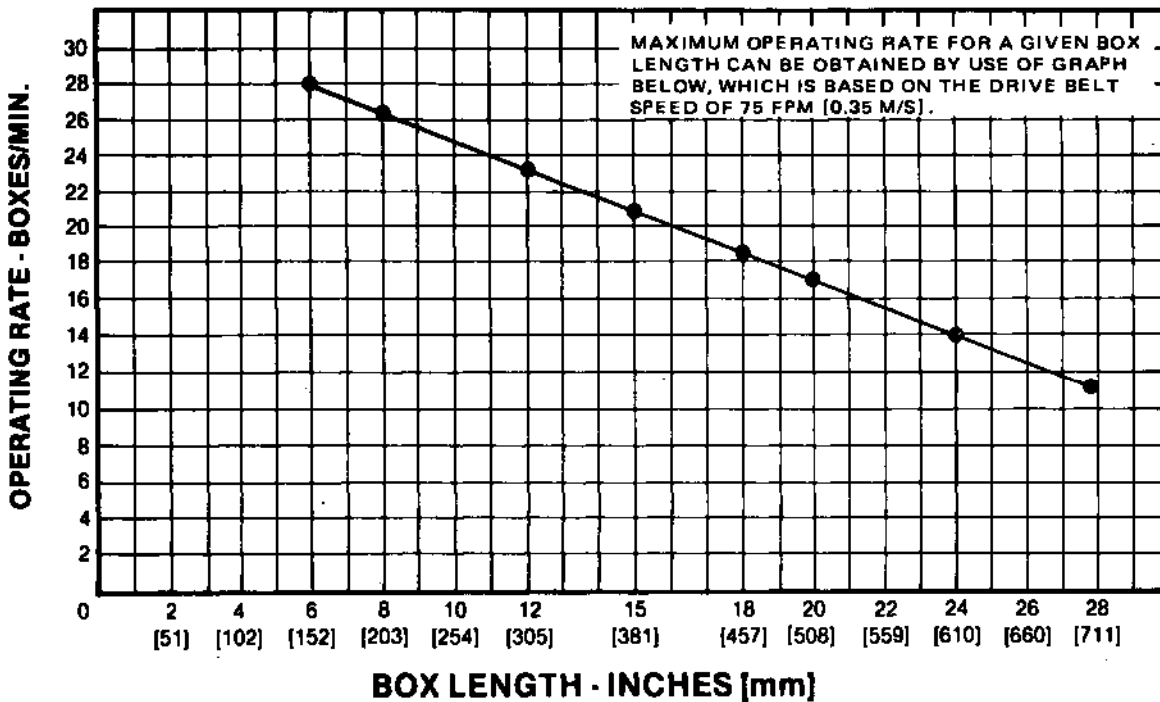

4. Operating Conditions:

Use at 40° to 105° F [5° to 40° C] with clean, dry boxes.

**IMPORTANT SAFEGUARD**

Machine should not be washed down.

5. Tape:

"Scotch" brand pressure-sensitive film box sealing tapes.

6. Tape Width:

1 1/2 inches or 36 mm minimum to 2 inches [50 mm] maximum.

7. Tape Roll Diameter:

Up to 15 1/2 inches [395 mm] maximum on a 3 inch [76,2 mm] diameter core. (Accommodates all system roll lengths of "Scotch" brand film tapes.)

8. Tape Application Leg Length:

2 3/4 inches ± 1/4 inch [70 mm ± 6 mm]

(Specifications continued on next page.)

**Specifications (Continued)**

**9. Box Board:**

125 to 275 P.S.I. bursting test, single wall A, B, or C flute.

**10. Box Weight and Size Capacities**

A. Box weight, filled - 5 lbs. [2,3 kg] minimum, 85 lbs. [37 kg] maximum

B. Box size:	Minimum	Maximum
Length -	6.0 inches or 150 mm	unlimited
Width -	6.0 inches or 150 mm *	20 inches or 500 mm
Height -	4.75 inches or 120 mm	20 inches or 500 mm

\* Note: Cartons smaller than 8 inches or 200 mm in width may require more frequent belt replacement because of limited contact area.

Special modifications may be available for carton sizes not listed above. Contact your 3M Representative for information.

**Note:** The Case Sealer can accommodate most boxes within the size range listed above. However, if the box length (in direction of seal) to box height ratio is .5 or less, then several boxes should be test run to assure proper machine performance.

**DETERMINE THE BOX LIMITATIONS BY COMPLETING THIS FORMULA:**

$$\frac{\text{BOX LENGTH IN DIRECTION OF SEAL}}{\text{BOX HEIGHT}} \quad \text{SHOULD BE GREATER THAN .5}$$

Any box ratio approaching this limitation should be test run to assure performance.

## Set-Up Procedure

It is recommended that the 22A-S Case Sealer be set-up and operated with product before placing it in the production line. This approach will allow your thorough review and familiarization with the 22A-S before subjecting it and operating personnel to a production situation where time for set-up, adjustments, and operator training usually becomes limited.

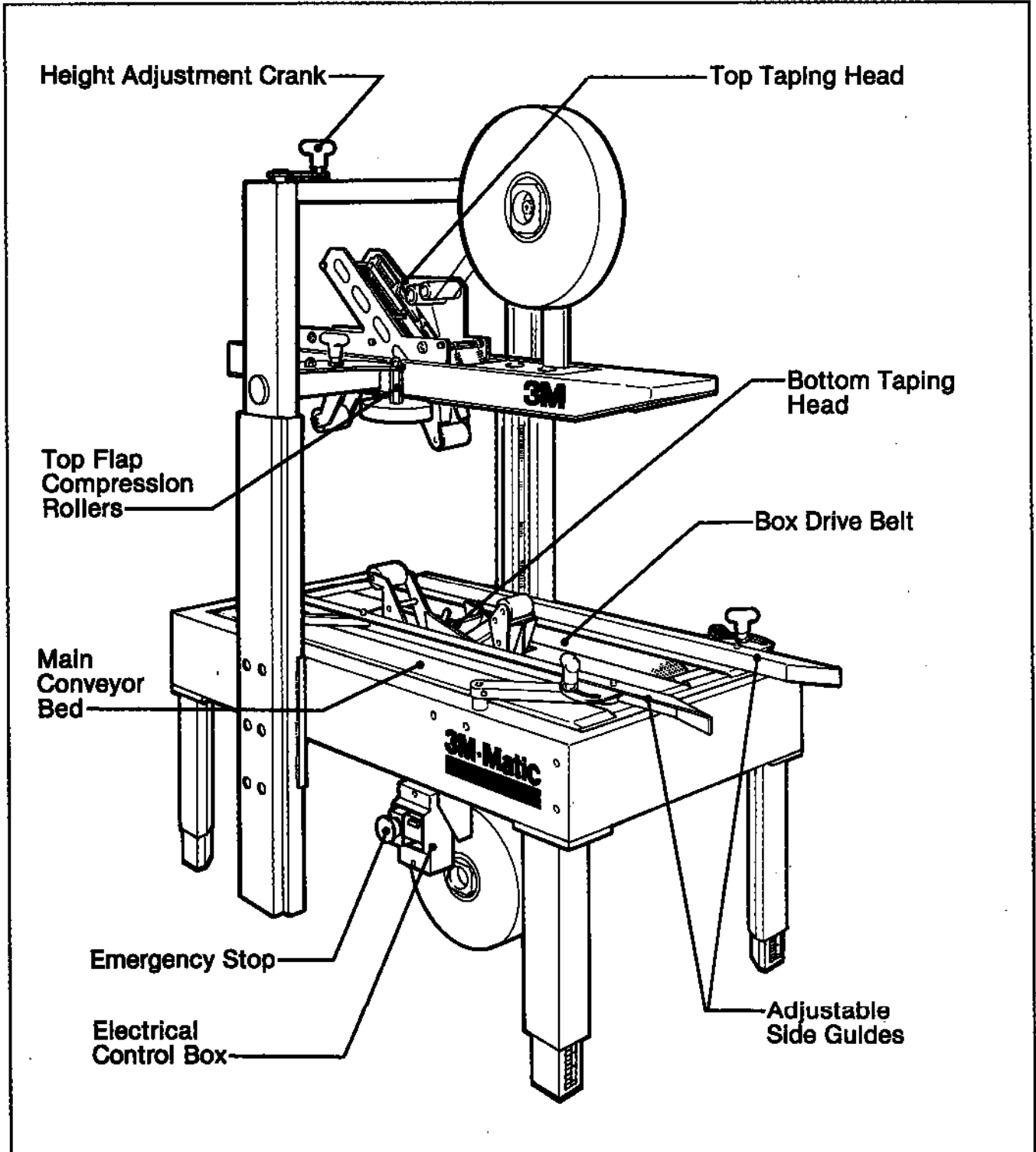

Figure 1 - Set-Up Instructions - Case Sealer Components - Left Front View



## Set-Up Procedure (Continued)

The following instructions are presented in the order recommended for setting up and installing the 22A-S Case Sealer, as well as for learning the operating functions and adjustments. Following them step by step will result in your thorough understanding of the machine and an installation in your production line that best utilizes the many features built into the 22A-S Case Sealer.

### Conveyor Bed Height:

The 22A-S Case Sealer is equipped with four adjustable legs that are located at the corners of the frame. The legs can be adjusted to obtain different machine conveyor bed heights from 20 1/2 inches [520 mm] minimum to 31 1/2 inches [800 mm] maximum.

The recommended minimum machine conveyor bed height (measured from floor) is 24 inches [610 mm].

Refer to Figure 2A and set the conveyor bed height as follows:

1. Block up the machine frame to allow adequate leg adjustment.
2. Loosen, but do not remove, two M8 x 16 mm socket head screws in one leg. Adjust the leg length for the desired conveyor bed height. Retighten the two screws to secure the leg. Adjust all four legs as noted.

The tape drum bracket assembly, located on the bottom taping head, has two mounting positions to allow maximum tape roll capacity through the machine conveyor bed height range.

For conveyor bed heights 24 inches and above, use mounting position shown in Figure 2B.

For conveyor bed heights below 24 inches, use mounting position shown in Figure 2C.

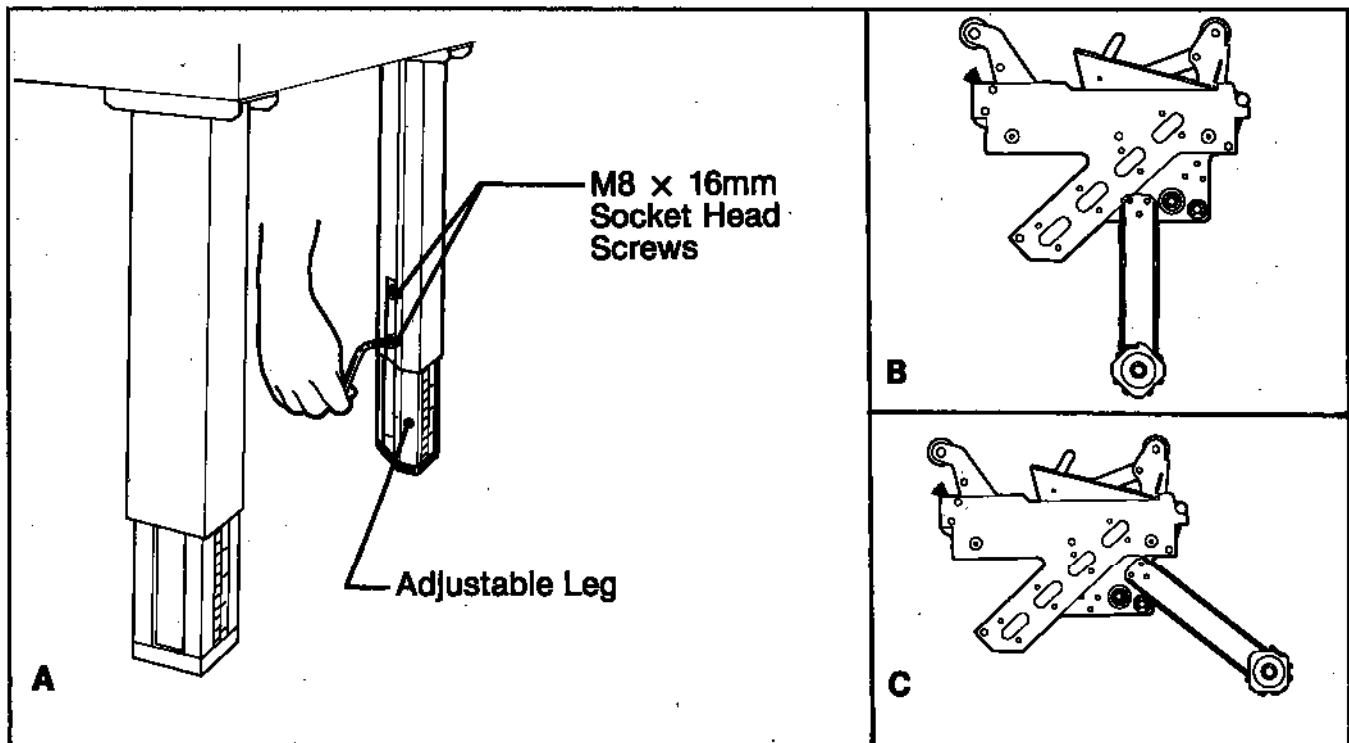

Figure 2 - Conveyor Bed Height Adjustment and Tape Drum Bracket Position

## Set-Up Procedure (Continued)

### Electrical Connection

The electrical control box, shown in Figure 1, contains the "On-Off" switch with pre-set circuit breaker and can be located on either side of the main conveyor for customer operating convenience. A standard three conductor power cord with plug is provided at the back of the electrical control box for 115 Volt, 60 Hz electrical service. The receptacle providing this service shall be properly grounded. Before the power cord is plugged into 115 Volt, 60 Hz outlet, make sure the switch is "Off" and that all packaging materials and tools are removed from the machine.

**Note:** Machines outside the U.S. may be equipped with 220/240 Volt, 50 Hz systems, or other electrical requirements compatible with local practice.

#### IMPORTANT SAFEGUARDS

1. BOTH THE TOP AND BOTTOM TAPING HEADS UTILIZE EXTREMELY SHARP KNIFE BLADES ON THE ORANGE CUTTER LEVER ASSEMBLY AND WHICH ARE LOCATED UNDER THE BLADE GUARD WHICH HAS THE "CAUTION - SHARP KNIFE" LABEL. BEFORE WORKING WITH THE TAPING HEADS OR ATTEMPTING TO LOAD THE TAPE, REFER TO FIGURE 3A AND IDENTIFY THE BLADE LOCATION. KEEP HANDS OUT OF THESE AREAS EXCEPT AS NECESSARY TO SERVICE THE TAPING HEADS.
2. NEVER ATTEMPT TO WORK ON THE TAPING HEADS OR LOAD TAPE WHEN THE BOX DRIVE BELTS ARE RUNNING.
3. BOX DRIVE MOTORS ARE DESIGNED TO RUN AT A MODERATE TEMPERATURE OF 120° F [49° C]. IN SOME CASES THEY MAY FEEL WARM TO THE TOUCH.

### Tape Loading

The taping heads have been pre-set to accommodate 2 inch [50 mm] wide tape rolls. To apply 1 1/2 inch or 36 mm or 1 3/4 inch or 42 mm wide tapes, refer to "Adjustments" Section for set-up information. Two temporary threading needles are shipped in threaded position for initial tape loading convenience.

Retain these for continued use in the tape loading operation. For operator assistance, a threading diagram has been applied to the taping heads. However, it is recommended that the more detailed instructions and sketches in this manual be referred to the first few times the unit is loaded until the operator becomes thoroughly familiar with the tape loading operation. The bottom taping head can be removed from unit by lifting out for convenience in tape loading.

#### Tape Loading - Top Taping Head

**WARNING - NEVER ATTEMPT TO WORK ON THE TAPING HEADS OR LOAD TAPE WHEN THE BOX DRIVE BELTS ARE RUNNING. PERSONNEL INJURY OR EQUIPMENT DAMAGE CAN POTENTIALLY RESULT.**

1. It is first necessary to raise the top taping head. Utilize the height adjustment crank and move the top taping head to the fully raised position.
2. With the temporary threading needle already in position, as shown in Figure 3, follow the tape loading procedure from Figure 3C to complete the tape threading.

**Set-Up Procedure (Continued)**

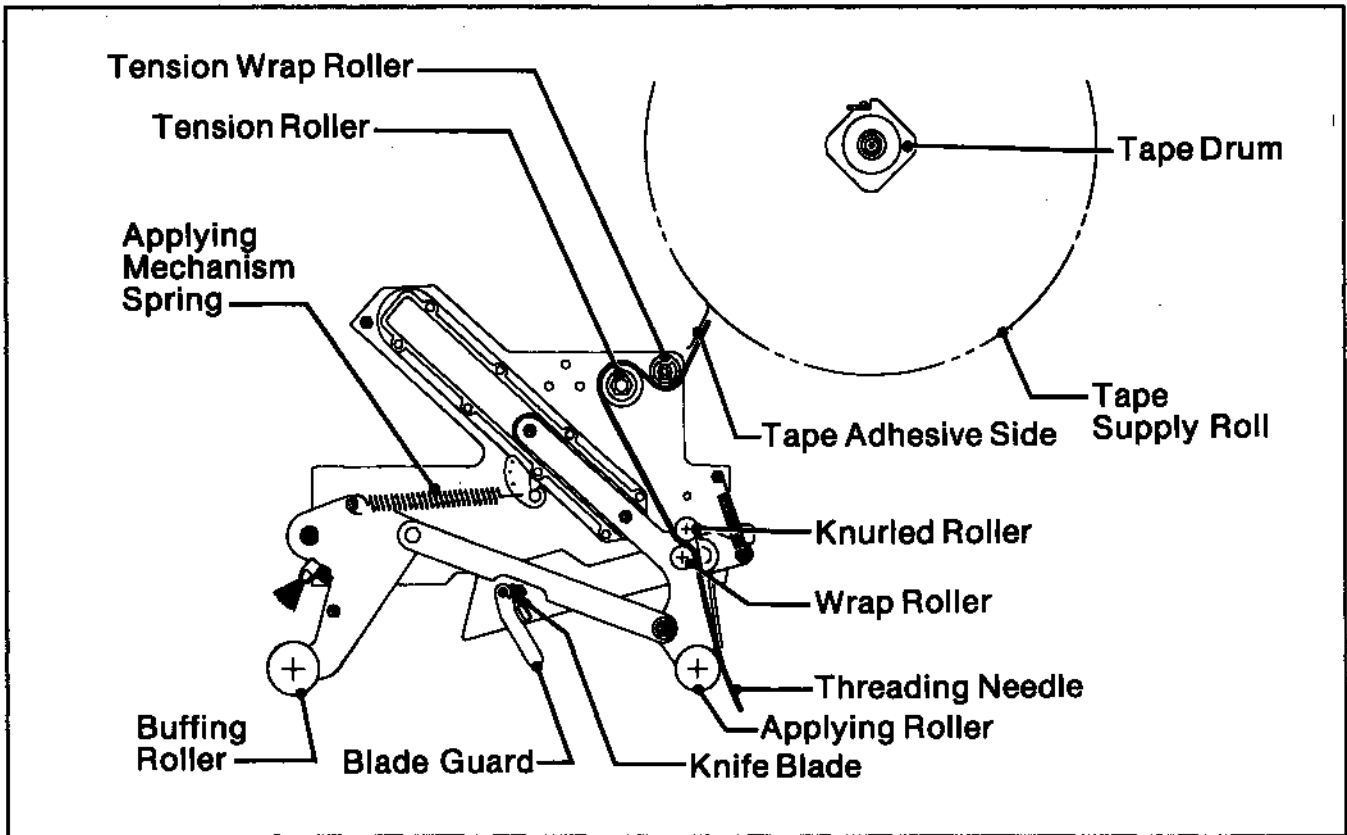

**Figure 3 - Tape Threading Diagram - Top Taping Head - Left Side View**

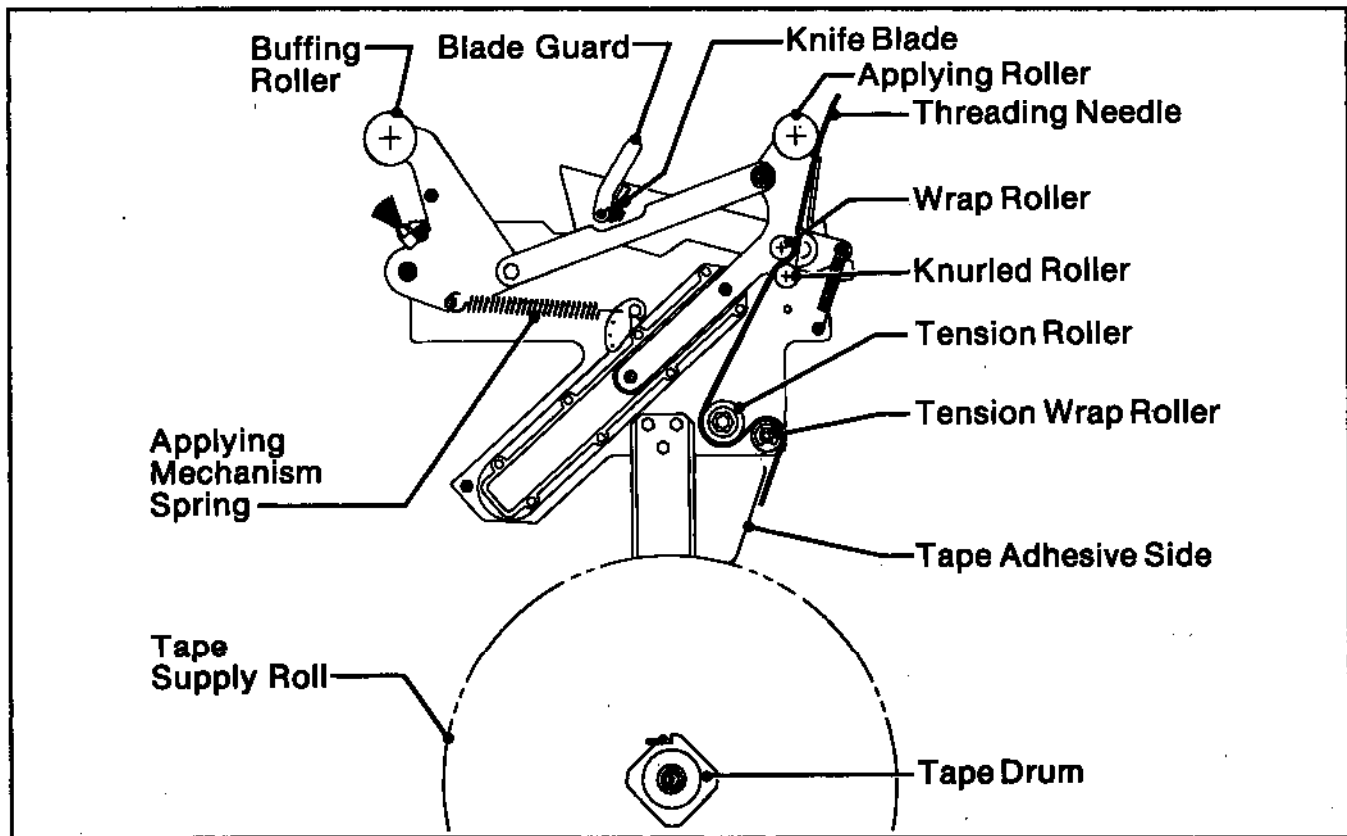

**Figure 3A - Tape Threading Diagram - Bottom Taping Head - Left Side View**

### Set-Up Procedure (Continued)

3. For subsequent tape loading operations, use the red plastic threading needle and follow the loading procedures from Figure 3B to complete the tape threading.

#### Tape Loading - Bottom Taping Head Refer to Figure 3A

The bottom taping head is loaded and threaded in the same manner as the top taping head.  
For ease in loading, first remove the bottom taping head from the conveyor bed and follow the top taping head tape loading procedure.

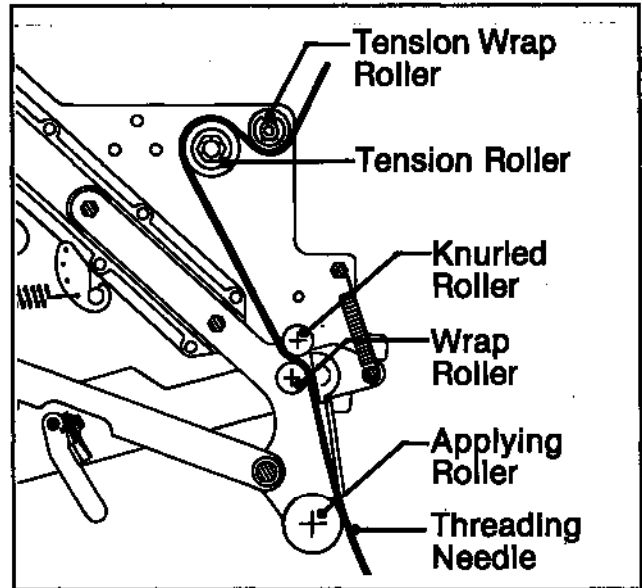

Figure 3B

#### Figure 3B

Insert the red plastic needle downward around rollers as illustrated.

#### Figures 3B and 3C

Place tape roll on drum to dispense tape from bottom of roll toward tension wrap roller with tape adhesive side in. Seat tape roll fully against back flange of drum. Adhere tape lead end to upper end of threading needle as shown.

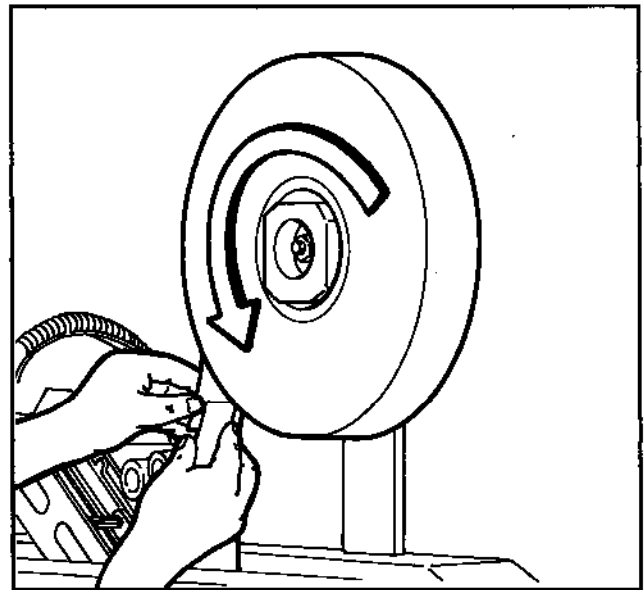

Figure 3C

#### Figure 3D

**WARNING - USE CARE WHEN WORKING NEAR BLADES AS BLADES ARE EXTREMELY SHARP. IF CARE IS NOT TAKEN, SEVERE INJURY TO PERSONNEL COULD RESULT.**

Manually turn tape roll to create slack tape while pulling threading needle through tape applying mechanism until needle is through and tape is in alignment with applying roller.

Excess tape can be cut with a scissors or knife at applying roller.

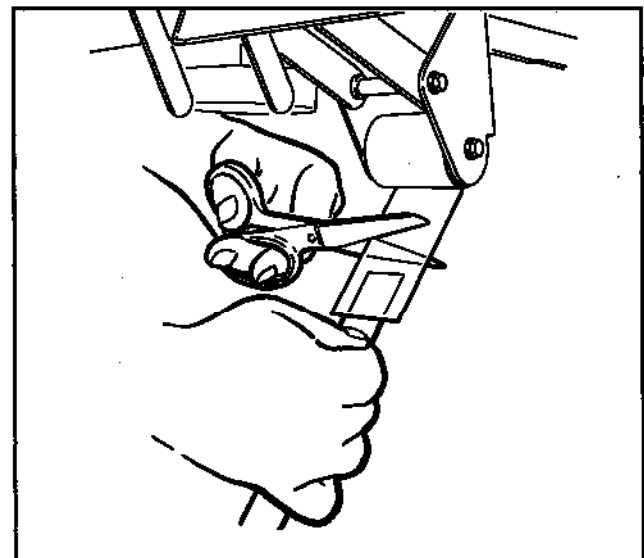

Figure 3D

## Set-Up Procedure (Continued)

### Box Size Set-Up and Operation

**Figure 4**

Once both taping heads are loaded with tape, the top taping head can be positioned for the box height being sealed by means of the height adjustment crank. Turn clockwise to lower head, counterclockwise to raise head.

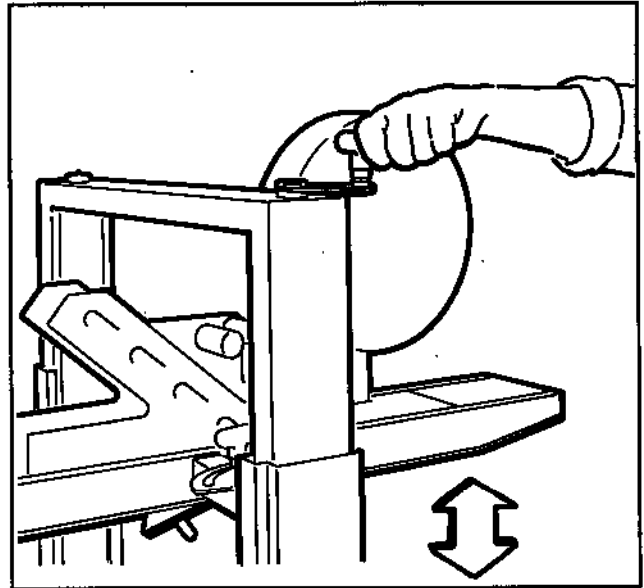

**Figure 4**

**Figure 5**

Place box on infeed conveyor with both top and bottom flaps folded and insert under top head skis approximately 2 inches or 50 mm. Lower top head until all flaps are fully closed. Align box top flap center seam with arrows on front of skis.

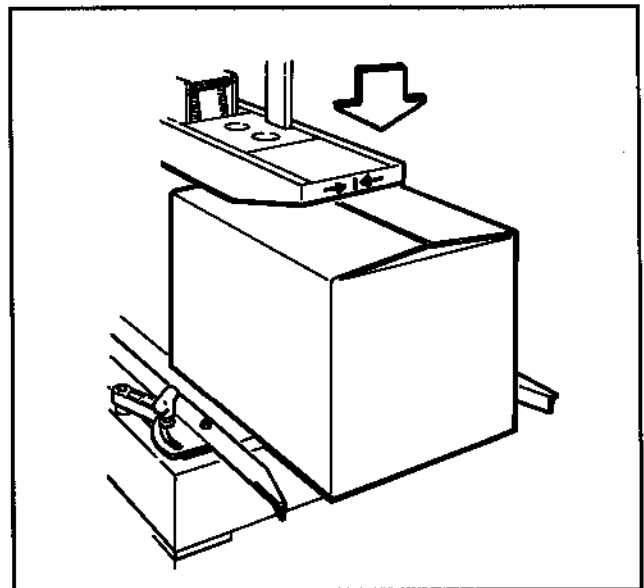

**Figure 5**

**Figure 6**

Move side guides against each side of box to hold box in position, centered on arrows on front of ski. Tighten hand knobs to secure side guides.

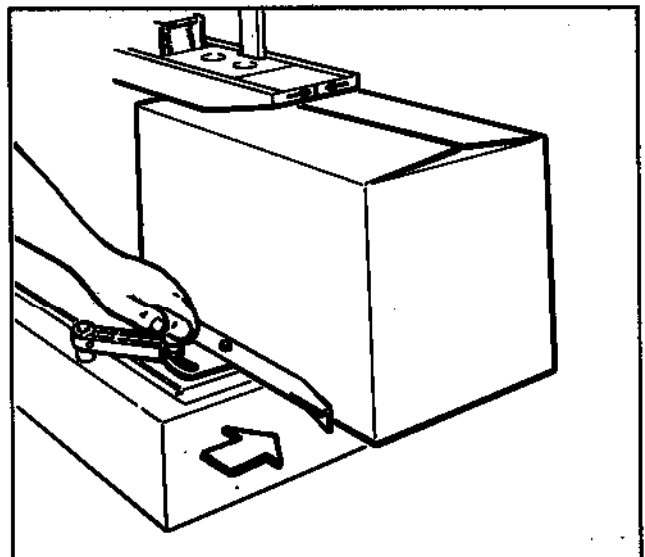

**Figure 6**

**Set-Up Procedure (Continued)**

**Figure 7**

Turn electrical switch to "On" to start drive belts. Move box forward under top taping head until it is taken away by drive belts. If box is hard to move under head or is crushed, raise top head slightly. If box movement is jerky or stops under top head, lower top head slightly to add more pressure between box and drive belts.

**Note:** Top head has unique feature for overstuffed boxes. Top head will raise automatically for this type of condition.

**CAUTION - IF DRIVE BELTS ARE ALLOWED TO SLIP ON BOX, EXCESSIVE BELT WEAR WILL OCCUR.**

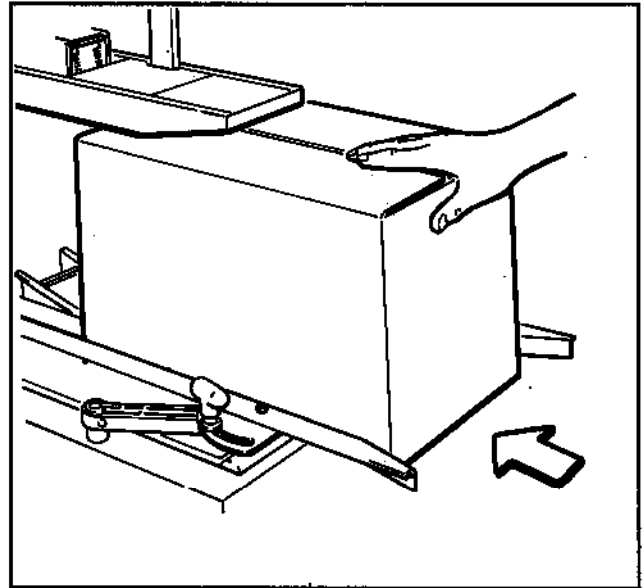

**Figure 7**

**Figure 8**

Adjust Top Flap Compression rollers against top edge of box and tighten knobs to secure rollers in operating position.

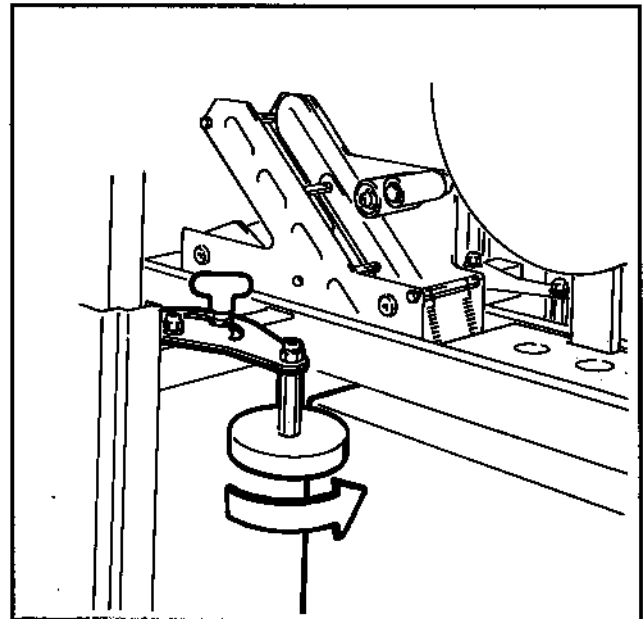

**Figure 8**

## Adjustments

### Tape Web Alignment

Refer to Figure 9

The tape drum assembly on each taping head is pre-set to accommodate 2 inch [50 mm] wide tape, but is adjustable to provide alignment of narrower tapes. If adjustment is necessary to center the tape width on the centerline of the taping head (and therefore box center seam), make adjustment as follows:

1. Loosen hand knob behind tape drum on tape drum shaft.
2. Turn tape drum shaft in or out to center the tape web.
3. Tighten hand knob to secure the adjustment.

No other components require adjustment for tape web alignment.

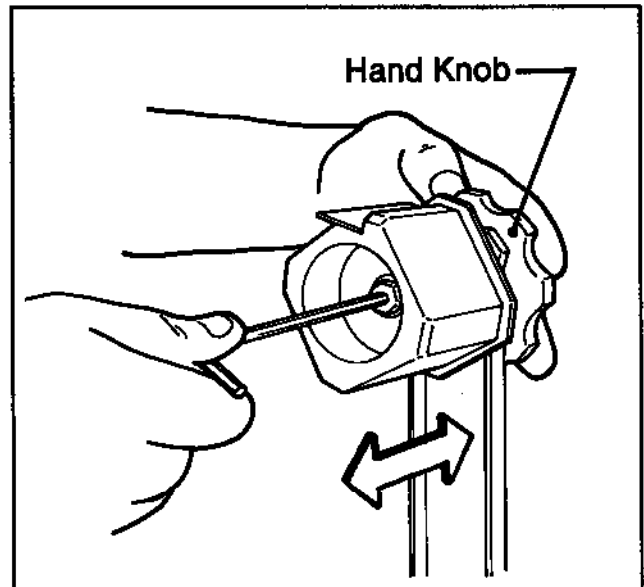

Figure 9

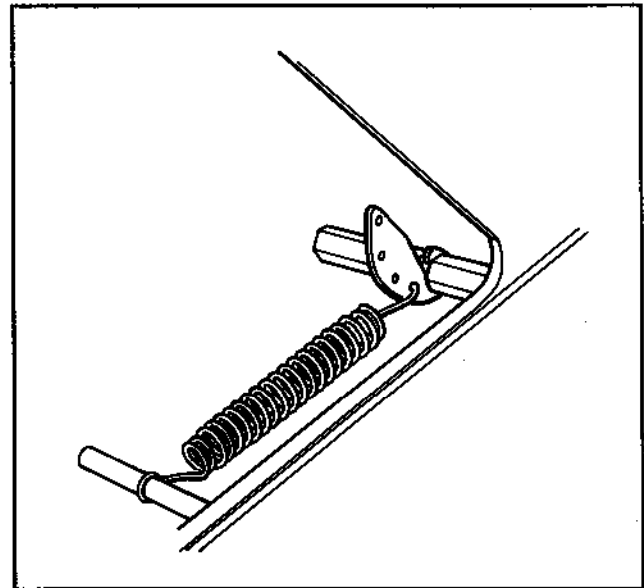

Figure 10

### Applying Mechanism Spring

The applying mechanism spring, shown in Figure 3A, controls applying and buffing roller pressure on the box and returns the mechanism to the reset position. The spring pressure is pre-set, as shown in Figure 10, for normal operation but is adjustable.

Removing the spring end loop from the spring holder and placing loop in other holes provided, as shown in Figure 11, will decrease the spring pressure.

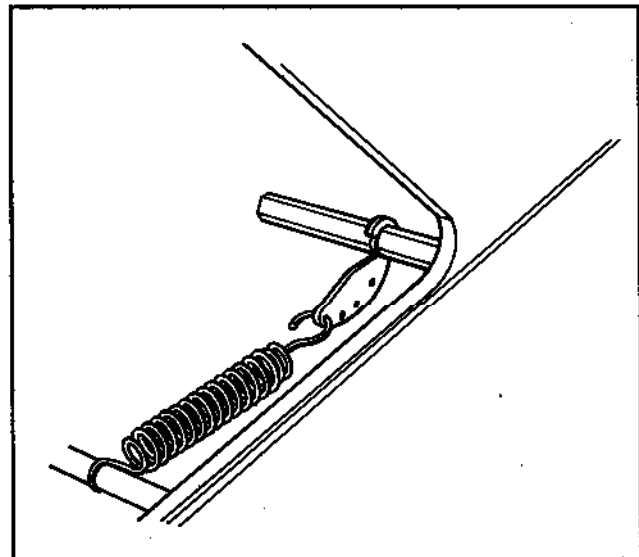

Figure 11

## Adjustments (Continued)

### One Way Tension Roller Assembly

The one way tension roller, shown in Figure 3A, is pre-set for normal operation. Should the one way tension roller assembly require replacement, the roller must have 1 pound [0,5 kg] tangential force when turning as illustrated in Figure 12.

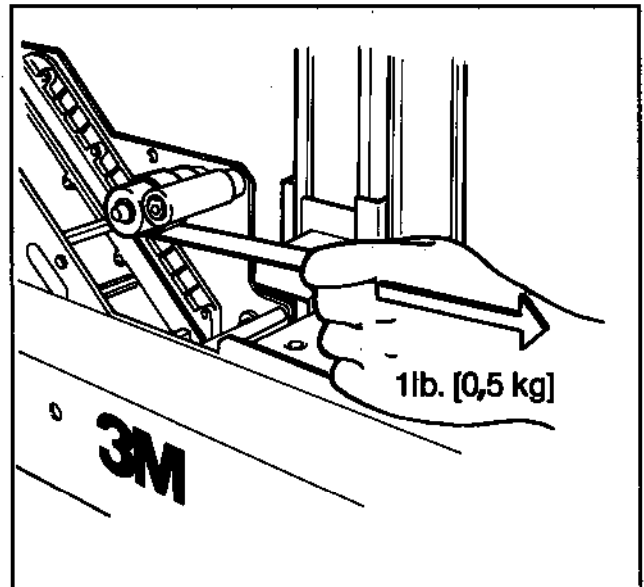

Figure 12



## Adjustments (Continued)

### Box Drive Belts

The two continuously moving box drive belts convey boxes through the tape applying mechanism. The box drive belts are powered by the electric motor through the timing belt/pulley transmission.

Tension adjustment of these belts may be required during normal operation. Belt tension must be adequate to positively move the box through the machine and they should run fully on the surface of the pulleys at each end of the frame. The idler pulleys on the infeed end are positioned by adjustment screws. Adjustment of these screws can be made by using the following steps to provide proper tension. Each belt is adjusted separately.

**WARNING - TURN OFF ELECTRICAL POWER SUPPLY AND DISCONNECT POWER CORD FROM ELECTRICAL SUPPLY BEFORE BEGINNING ADJUSTMENTS. IF POWER CORD IS NOT DISCONNECTED, SEVERE INJURY TO PERSONNEL COULD RESULT.**

### Box Drive Belts

Refer to Figure 13

Step 1. Remove and retain center plates and 4 screws.

Step 2. Remove and retain eight M6 x 12 mm socket head screws to remove conveyor tops from housing.

Belt tension is obtained by uniform tightening of the adjustment screws so that a moderate pulling force of 7 lbs. [3,5 kg] applied at the midspan, as shown in Figure 14, will deflect the belt 1 inch [25 mm].

This will assure positive contact between the belt and the drive pulley on the discharge end of the taping head.

Refer to Figure 15

Step 3. Loosen, but do not remove, lock nut M20 x 16 with socket wrench provided.

Step 4. Reset the tension on the drive belt as needed. Adjust the M8 x 40 mm hex head screws, (out to increase - in to decrease). Tighten lock nut to secure tension setting.

Step 5. Reverse procedure in steps 1 and 2 above to reassemble the unit.

Adjustments (Continued)

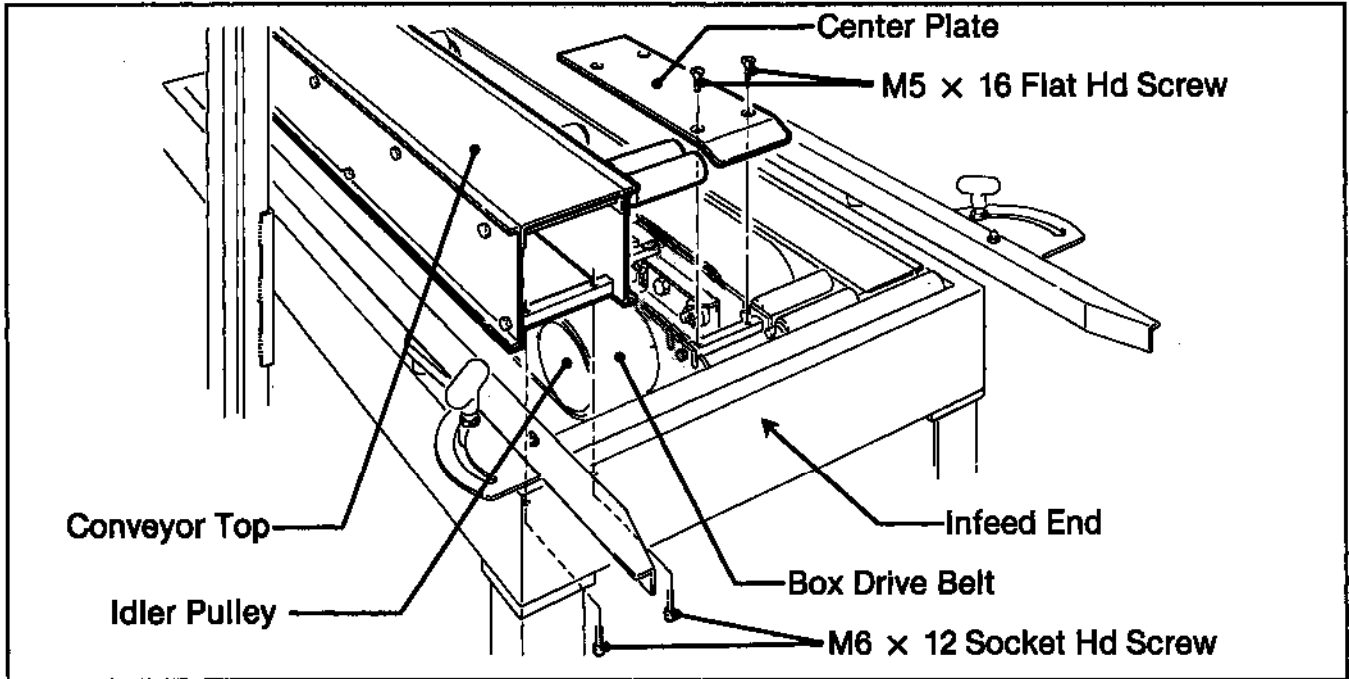

Figure 13 - Box Drive Belt Adjustment - Frame Bed Infeed End

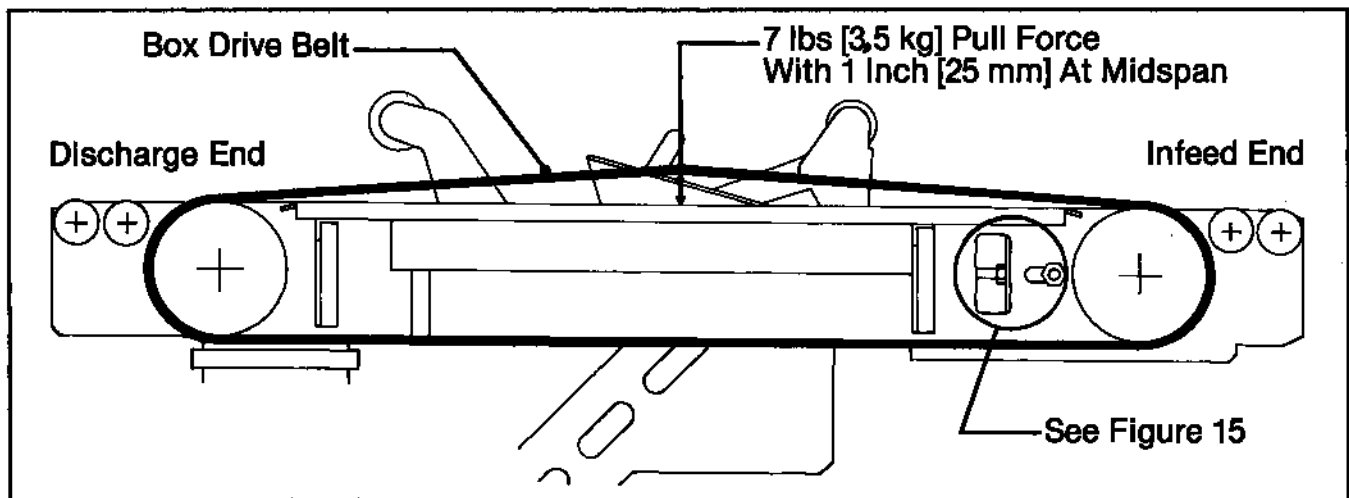

Figure 14 - Box Drive Belt Tension Adjustment - Left Side View

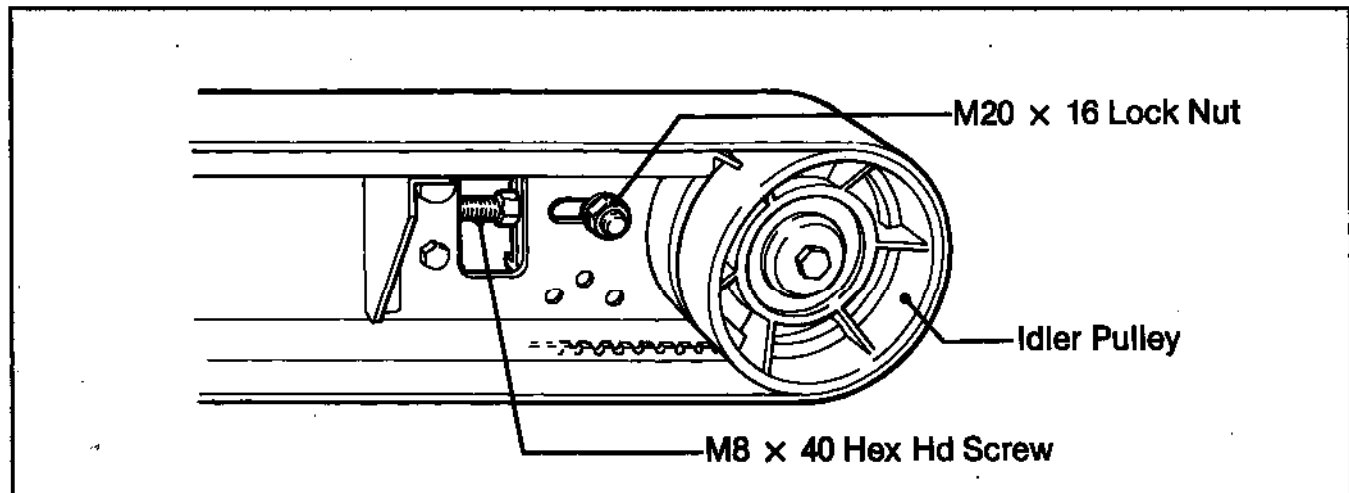

Figure 15 - Tension Adjustment - Left Side View

## Maintenance

The 22A-S Case Sealer has been designed for long, trouble free service. The machine will perform best when it receives routine maintenance and cleaning. Machine components that fail or wear excessively should be promptly repaired or replaced to prevent damage to other portions of the machine or to the product.

**WARNING - TURN OFF ELECTRICAL POWER SUPPLY AND DISCONNECT POWER CORD FROM ELECTRICAL SUPPLY BEFORE BEGINNING MAINTENANCE. IF POWER CORD IS NOT DISCONNECTED, SEVERE INJURY TO PERSONNEL COULD RESULT. USE CARE WHEN REPLACING BLADES AS BLADES ARE EXTREMELY SHARP. IF CARE IS NOT TAKEN, SEVERE INJURY TO PERSONNEL COULD RESULT.**

## Blade Replacement

Refer to Parts Illustrations, yellow pages, Figure 2569.

1. Loosen, but do not remove, the blade screws (4) holding the blade. Remove the old blade.
2. Position the new blade with the beveled side toward the blade holder. Tighten the blade screws to secure the blade.

The same steps are followed on the Top and Bottom Taping Heads. Connect the main power supply.

## Replacing Box Drive Belts

**DO NOT REMOVE BOTTOM TAPING HEAD.**

Install new belts and adjust belt tension as noted in Step 4 under adjustments.

## Maintenance (Continued)

### Cleaning Of The Machine

**CAUTION - NEVER ATTEMPT TO REMOVE DIRT BY BLOWING IT OUT WITH COMPRESSED AIR. THIS CAN CAUSE THE DIRT TO BE BLOWN INSIDE THE MOTOR, AND SLIDING SURFACES. GRITTY DIRT IN THESE AREAS CAN CAUSE SERIOUS EQUIPMENT DAMAGE. NEVER WASH DOWN EQUIPMENT.**

Regular slotted containers produce a great deal of dust and paper chips when processed or handled in equipment. If this dust is allowed to build up on machine components, it can cause component wear and overheating of drive motor. The dust build up can best be removed from the machine by a shop vacuum. Depending on the number and type of boxes sealed in the 22A-S Case Sealer, this cleaning should be done approximately once per month. If the boxes sealed are dirty, or if the environment in which the machine operates is dusty, cleaning on a more frequent basis may be necessary. Excessive dirt build up that cannot be removed by vacuuming should be wiped off with a damp cloth.

#### Cut-Off Blade:

Should tape adhesive build-up occur, carefully wipe clean with oily cloth.

#### Electrical Schematic

**WARNING - TURN OFF ELECTRICAL POWER SUPPLY AND DISCONNECT POWER CORD FROM ELECTRICAL SUPPLY BEFORE BEGINNING MAINTENANCE. IF POWER CORD IS NOT DISCONNECTED, PERSONNEL COULD BE EXPOSED TO DANGEROUS VOLTAGES. SEVERE INJURY OR EQUIPMENT DAMAGE COULD RESULT.**

Figure 16 illustrates the electrical system of the 22A-S Case Sealer. No adjustments to the electrical systems are required.

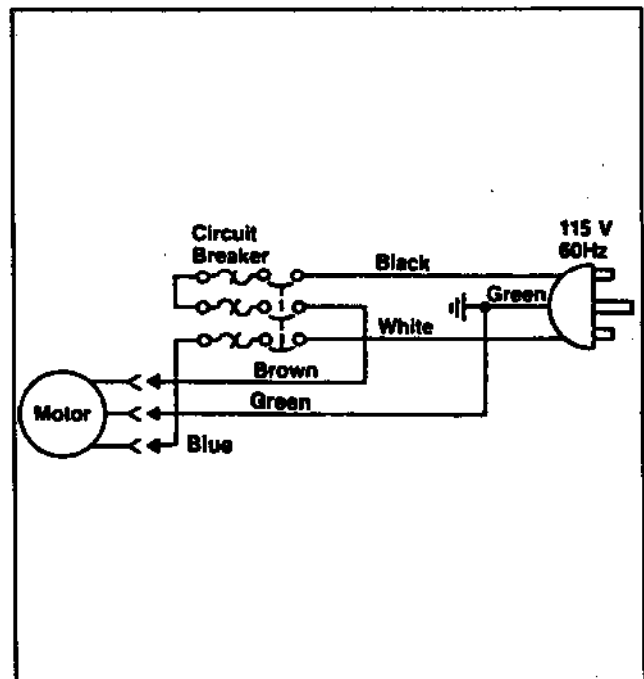

Figure 16

#### Circuit Breaker

The 22A-S Case Sealer is equipped with a circuit breaker which trips the "On-Off" switch to tripped position. If circuit is overloaded and circuit breaker trips, wait 2 minutes, move to "Off", then turn "On". Located inside the electrical control box on the side of the main frame just below the conveyor bed, the circuit breaker has been pre-set and requires no further maintenance.

## Maintenance (Continued)

### Lubrication - Mechanical

Like most other equipment, the Case Sealer must be properly lubricated to insure long, trouble/free service. Most of the machine bearings are permanently lubricated and sealed and do not need to be greased. The drive motor is also permanently lubricated and should not require additional lubrication.

Figure 17 and 18 illustrate the taping head and frame points which should be lubricated every 250 hours of operation. The oil can supplied with the Case Sealer can be utilized to lubricate the rotating and pivoting points noted by the arrows with SAE #30 non-detergent oil. At the same time, a small amount of multipurpose grease should be applied to the end of each spring where the loop is secured at an eyelet, post, or hole.

**CAUTION - WIPE OFF EXCESS OIL AND GREASE; IT WILL ATTRACT DUST AND DIRT WHICH CAN CAUSE PREMATURE EQUIPMENT WEAR AND JAMMING. TAKE CARE THAT OIL AND GREASE ARE NOT LEFT ON THE SURFACE OF ROLLERS AROUND WHICH TAPE IS THREADED, AS IT CAN CONTAMINATE THE TAPE'S ADHESIVE.**

### Blade Oiler Pad

The taping heads are equipped with a blade oiler pad that has been pre-lubricated at the factory to provide a film of oil on the cut-off blade to reduce adhesive build-up. Apply SAE #30 non-detergent oil as needed. Do not saturate.

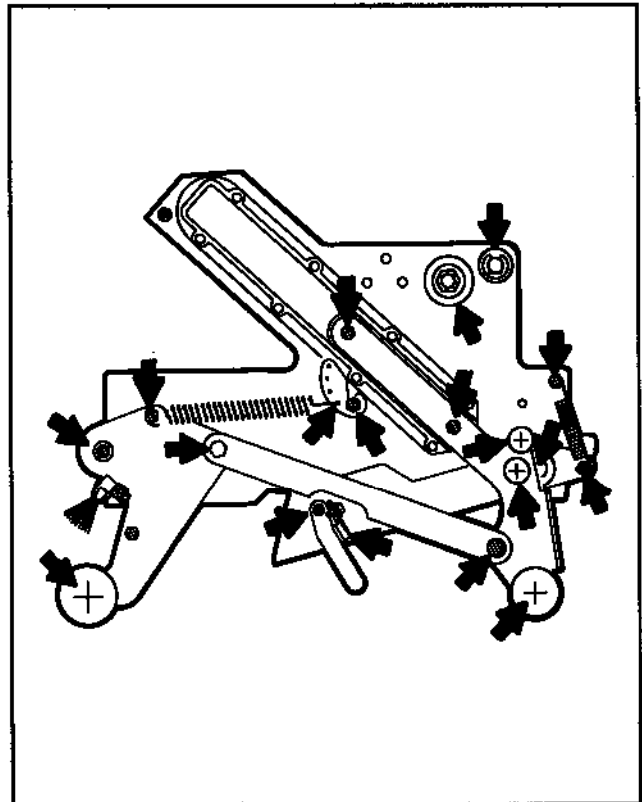

Figure 17 - Lubrication Points - Top And Bottom Taping Heads

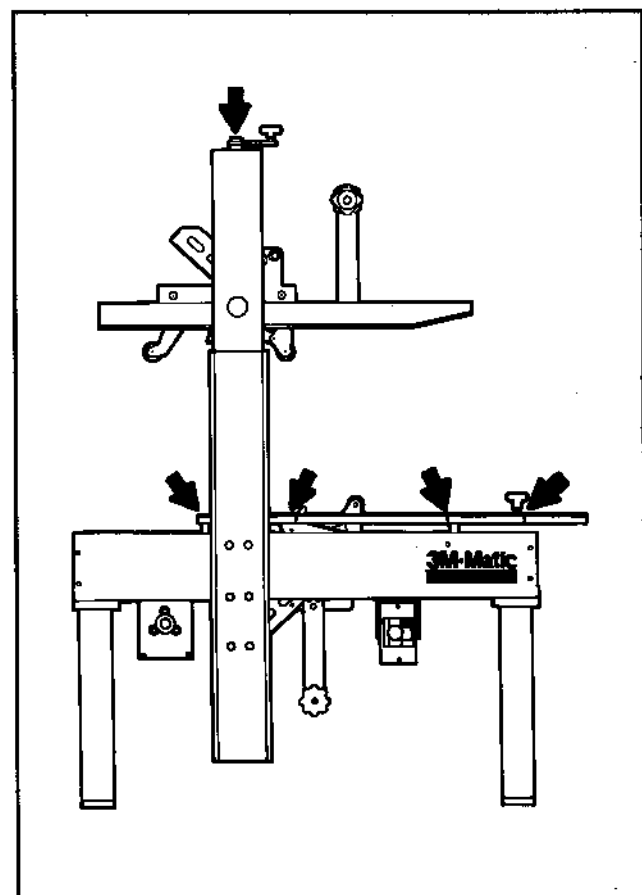

Figure 18 - Lubrication Points - Frame

## Replacement Parts And Service Information

### Spare Parts

It is suggested that the following spare parts be ordered and kept on hand:

Qty.	Ref. No.	3M Part Number	Description
1	2566-13	78-8057-6179-4	Roller - Applying
1	2567-8	78-8057-6178-6	Roller - Buffing
1	2567-12	78-8060-8237-2	Spring - Extension Top
2	2569-3	78-8060-8419-6	Blade - 2.56 inch/65 mm
2	2569-14	78-8060-8340-4	Spring - Cutter
1	2572-12	78-8060-8394-1	Spring - Extension Bottom
2	2535-33	78-8052-6722-2	Belt - Drive

### Tool Kit

The tool kit, P/N 78-8054-8732-5, is available as a stock item. The kit contains the necessary open end and hex socket wrenches for use with the metric fasteners on the 22A-S case sealer. The threading tool, Part No. 78-8017-9433-6, contained in above kit is also available as a replacement stock item. Refer to "How To Order Replacement Parts" for ordering information.

### How To Order Replacement Parts

1. Order parts by part number, part name, machine catalog number, model number and part quantity required.

Minimum billing on parts orders will be \$10.00.  
Replacement part prices available on request.

2. Replacement parts and part prices available direct from:

Dispenser Parts  
Route 4, Box 5B  
Amery, WI 54001

Note - Outside the U.S. contact the local 3M subsidiary for parts order information.

3. Refer to the front of the instruction manual for 3M equipment repair service information.

## **Attachments**

Additional information on the attachments listed below is included with the manual except where noted:

<u>Part Number</u>	<u>Attachment Name</u>
78-8052-6553-1	Box Hold Down Attachment, Model 18500
78-8052-6554-9	Caster Kit Attachment, Model 18500
78-8060-7498-1	Conveyor Extension Attachment, Model 18500

**SST Taping Head Assemblies, Model 18900**  
**Replacement Parts Illustrations and Parts Lists**

1. Refer to **Taping Head Assemblies** figure to find all the parts illustrations identified by figure numbers.
  
2. Refer to the figure or figures to determine the **individual parts** required and the parts reference number.
  
- 3 . The replacement parts list, that follows each illustration, includes the part number and part description for the parts in that illustration.

**Note** - The complete description has been included for standard fasteners and some commercially available components. This has been done to allow obtaining these standard parts locally, should the customer elect to do so.

4. Refer to page 19 - "**Replacement Parts and Service Information**" of this manual for replacement parts ordering information.



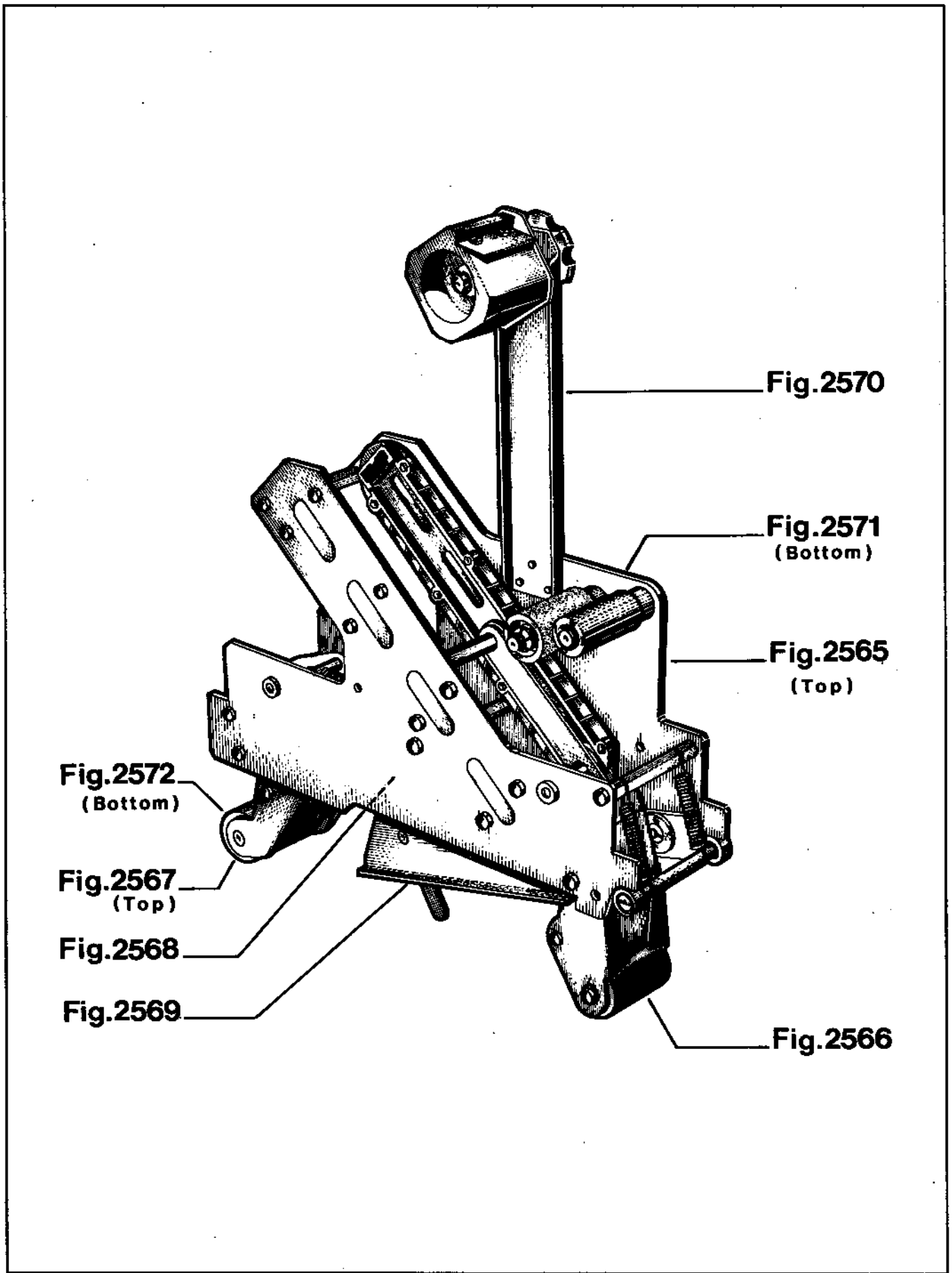

**Taping Head Assemblies**

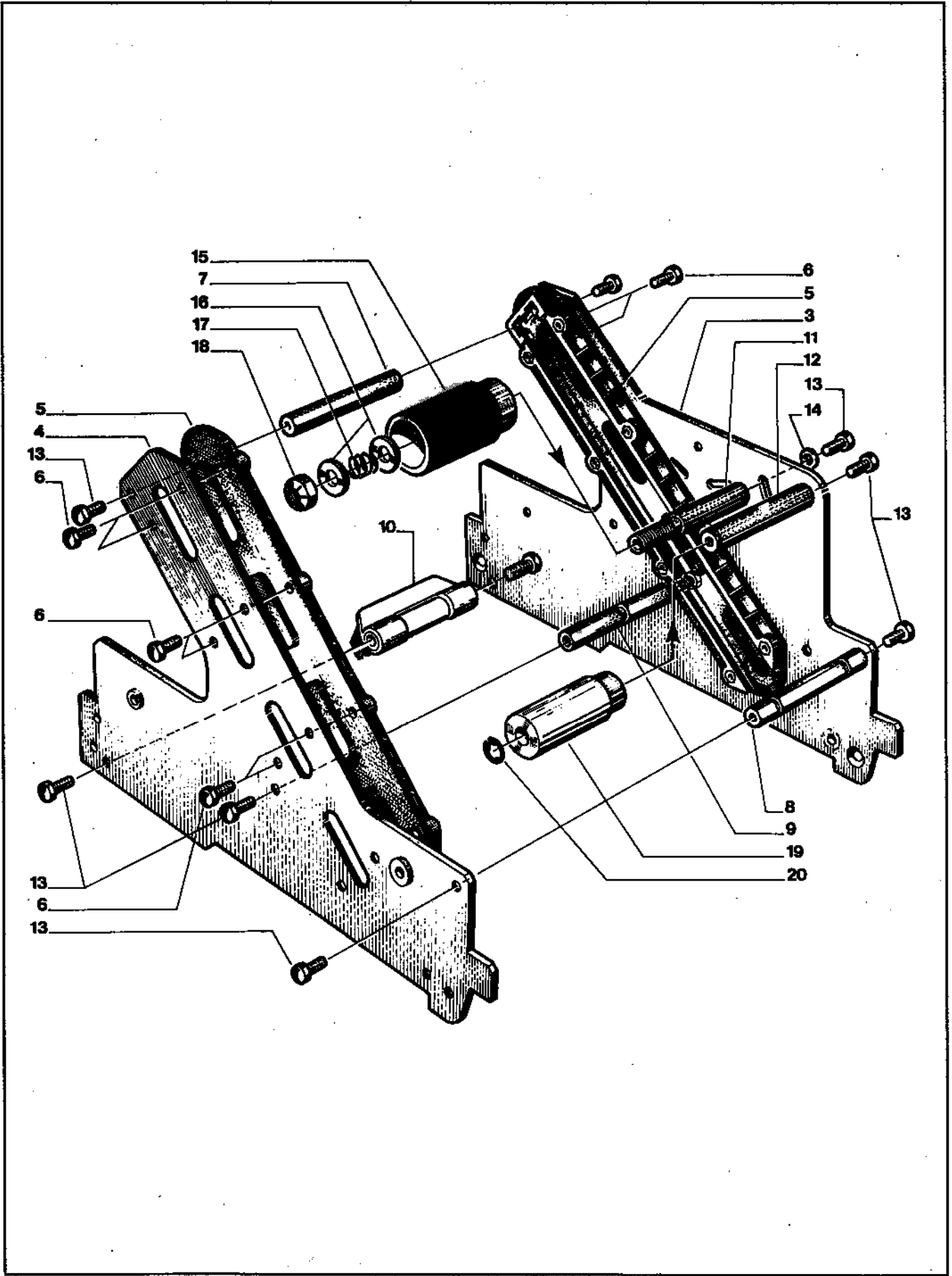

Figure 2565

**Figure 2565**

<b>Ref. No.</b>	<b>3M Part No.</b>	<b>Description</b>
2565-1	78-8060-8209-1	Frame Assembly - Right
2565-2	78-8060-8212-5	Frame Assembly - Left
2565-3	78-8060-8189-5	Frame - Right/Top
2565-4	78-8060-8191-1	Frame - Left/Top
2565-5	78-8060-8208-3	Guide - W/Nut
2565-6	78-8060-8205-9	Screw - Hex Hd M4 x 14
2565-7	78-8060-8193-7	Spacer - L 90
2565-8	78-8060-8194-5	Spacer - Hex 10 x 90
2565-9	78-8060-8192-9	Spacer - Hex 10 x 90
2565-10	78-8060-8207-5	Brush Assembly
2565-11	78-8060-8200-0	Shaft - Roller
2565-12	78-8060-8202-6	Shaft - Idler Roller
2565-13	78-8060-8204-2	Screw - Hex Hd M6 x 12
2565-14	78-8060-8312-3	Washer - Flat M6
2565-15	78-8052-6565-5	Roller - Top Tension
2565-16	78-8060-8315-6	Washer - Friction
2565-17	78-8060-8354-5	Spring
2565-18	78-8060-8201-8	Nut - M10 x 1 NHT70
2565-19	78-8052-6569-7	Roller - Wrap
2565-20	78-8060-8203-4	Ring - 10DIN6799

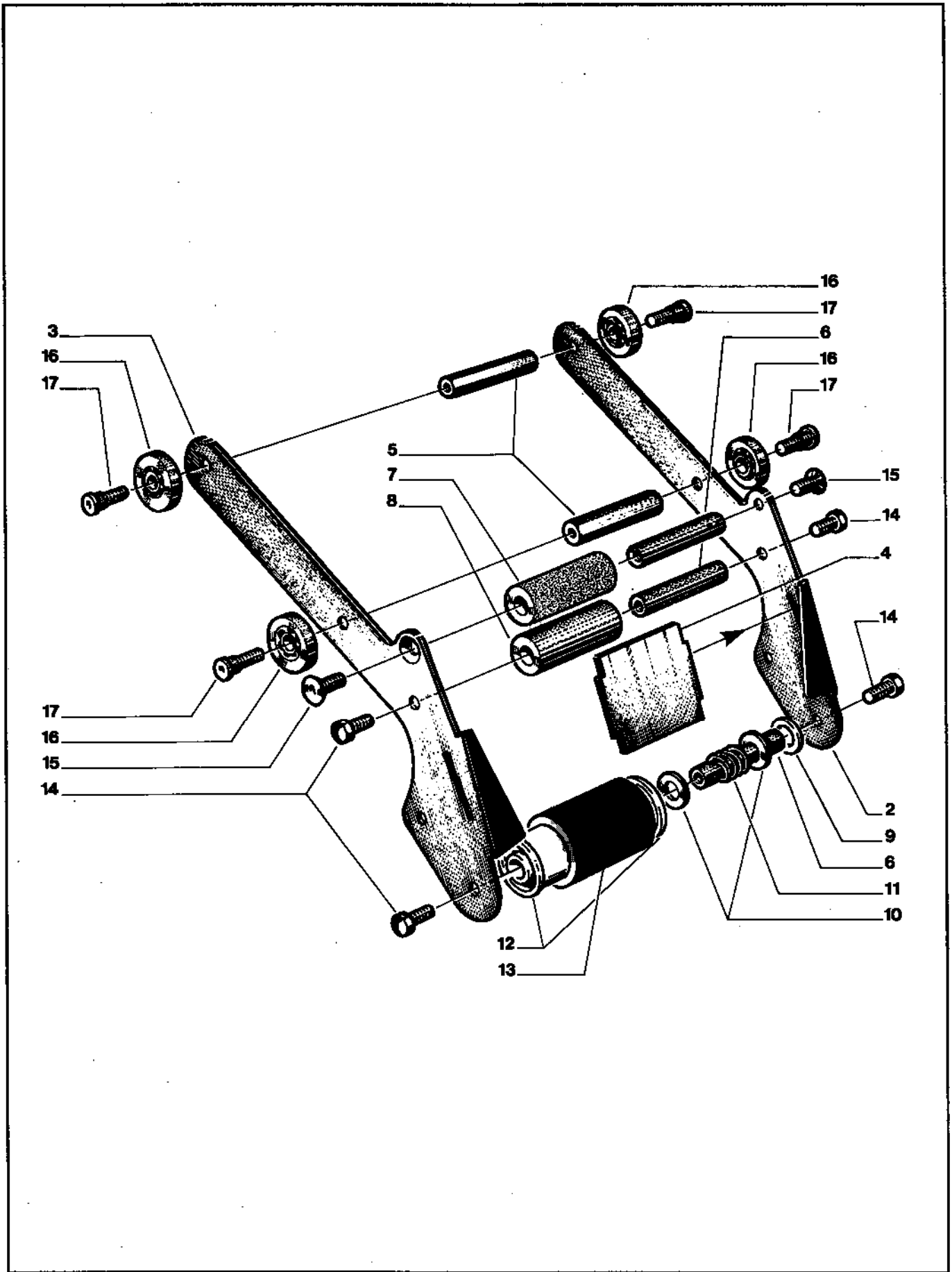

Figure 2566

**Figure 2566**

<b>Ref. No.</b>	<b>3M Part No.</b>	<b>Description</b>
2566-1	78-8060-8225-7	Entry Gr. Assembly
2566-2	78-8060-8213-3	Shoulder - Entry, Right
2566-3	78-8060-8214-1	Shoulder - Entry, Left
2566-4	78-8060-8215-8	Plate - Entry
2566-5	78-8060-8220-8	Spacer - 10 x 59,5
2566-6	78-8060-8217-4	Shaft - 10 x 60
2566-7	78-8060-8224-0	Roller - Knurled
2566-8	78-8052-6579-6	Roller - Wrap
2566-9	78-8017-9074-8	Washer - Nylon 15 mm
2566-10	78-8060-8315-6	Washer - Friction
2566-11	78-8060-8354-5	Spring
2566-12	78-8060-8395-8	Bushing - Applying Roller
2566-13	78-8057-6179-4	Roller - Applying NM
2566-14	78-8060-8204-2	Screw - Hex Hd M6 x 12
2566-15	78-8060-8223-2	Screw - Flat Hd M6 x 12
2566-16	78-8017-9082-1	Bearing - 30 mm Special
2566-17	78-8060-8241-4	Screw - Bearing Shoulder

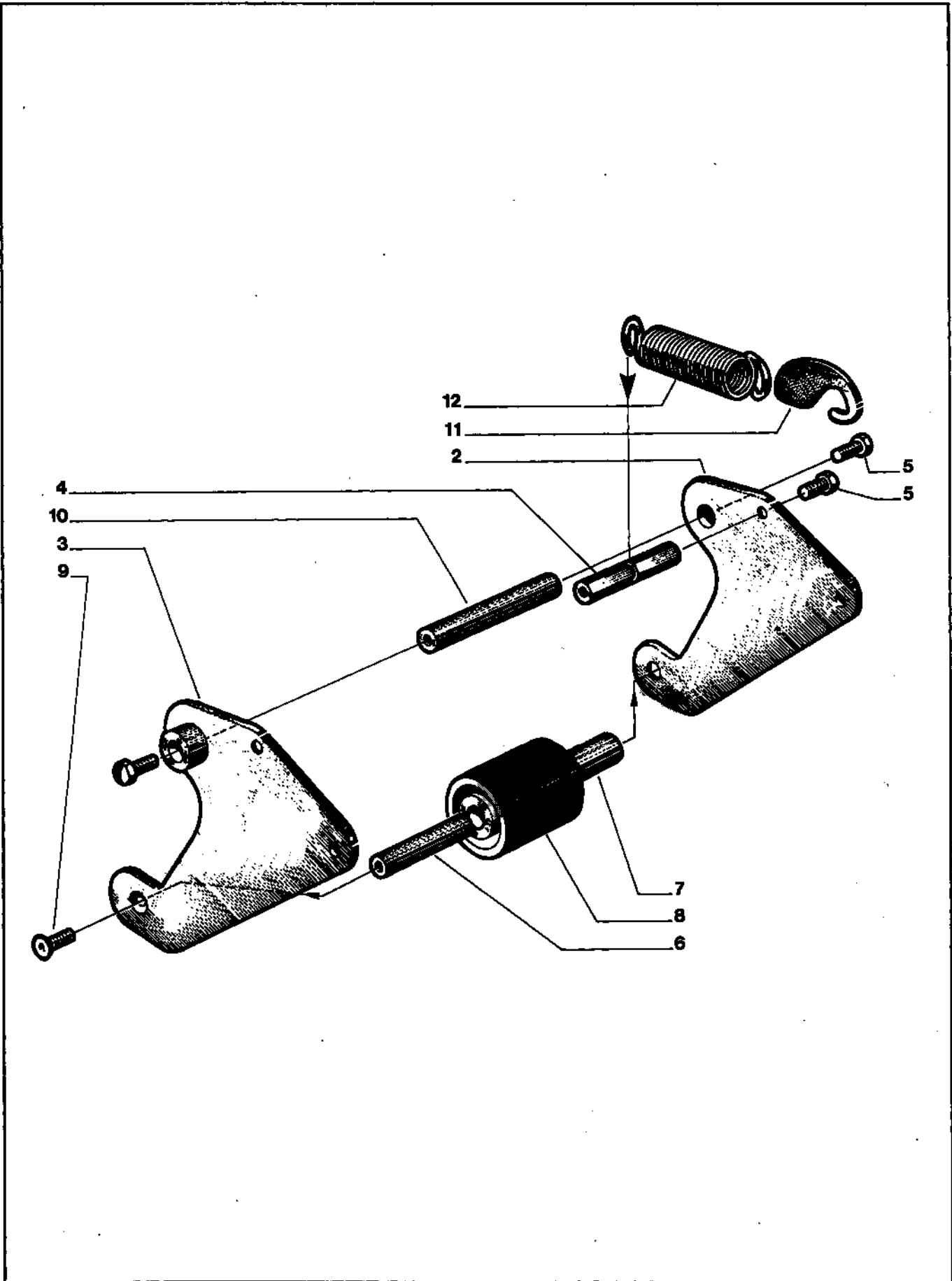

Figure 2567

**Figure 2567**

<b>Ref. No.</b>	<b>3M Part No.</b>	<b>Description</b>
2567-1	78-8060-8239-8	Exit Gr. Assembly
2567-2	78-8060-8226-5	Shoulder - Exit Right
2567-3	78-8060-8228-1	Shoulder - Exit Left
2567-4	78-8060-8229-9	Spacer - Hex 10 x 60
2567-5	78-8060-8204-2	Screw - Hex Hd M6 x 12
2567-6	78-8060-8217-4	Shaft - 10 x 60
2567-7	78-8052-6586-1	Bushing - Buffing Roller
2567-8	78-8057-6178-6	Roller - Buffing NM
2567-9	78-8060-8223-2	Screw - Flat Hd M6 x 12
2567-10	78-8060-8234-9	Shaft - 10 x 90
2567-11	78-8060-8238-0	Hock - Spring
2567-12	78-8060-8237-2	Spring -Main/Top

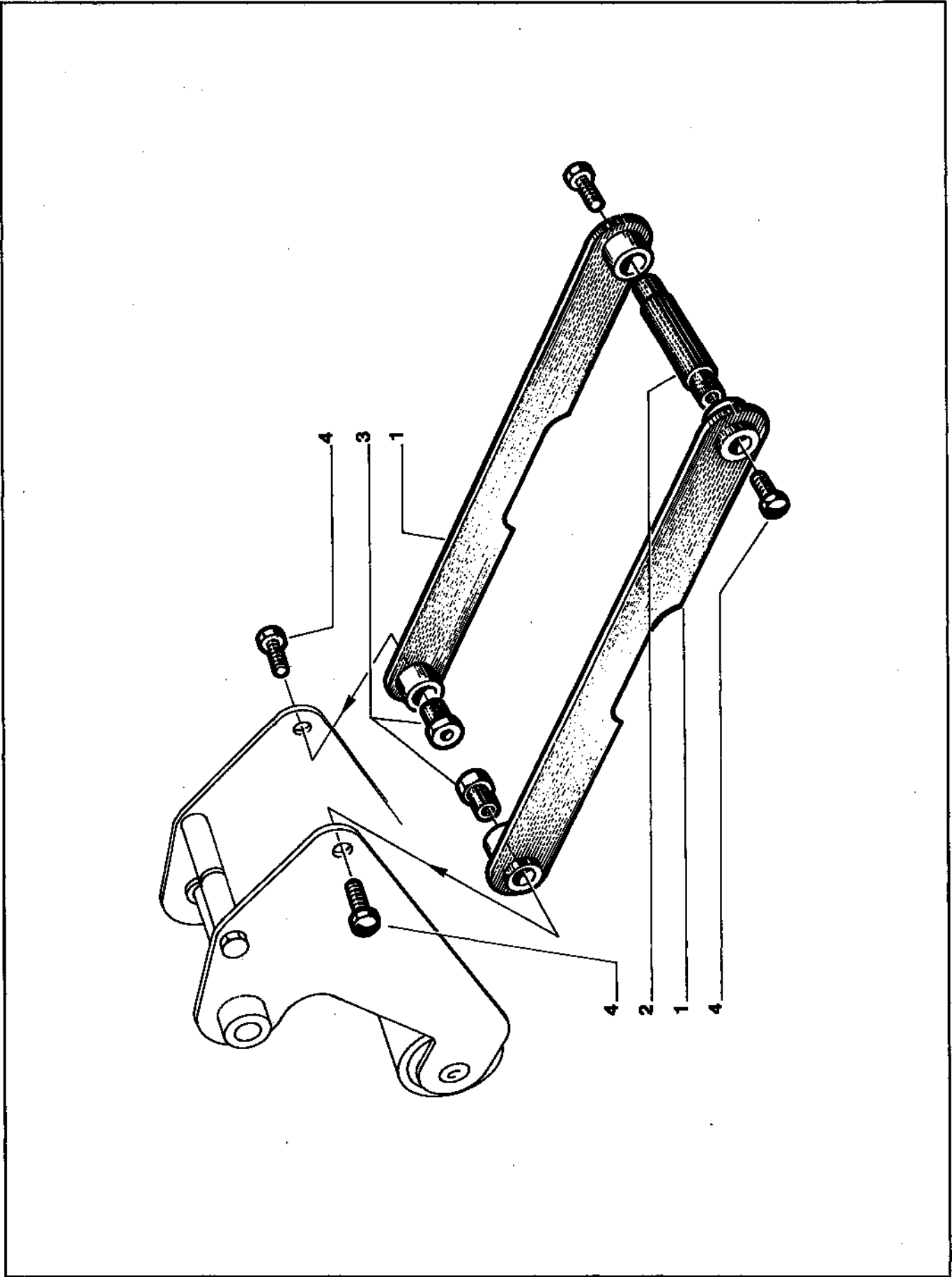

Figure 2568



**Figure 2568**

<b>Ref. No.</b>	<b>3M Part No.</b>	<b>Description</b>
2568-1	78-8060-8240-6	Lever
2568-2	78-8060-8249-7	Spacer - Lever
2568-3	78-8060-8250-5	Bushing - Lever
2568-4	78-8060-8300-8	Screw - Hex Hd M5 x 10, Metric

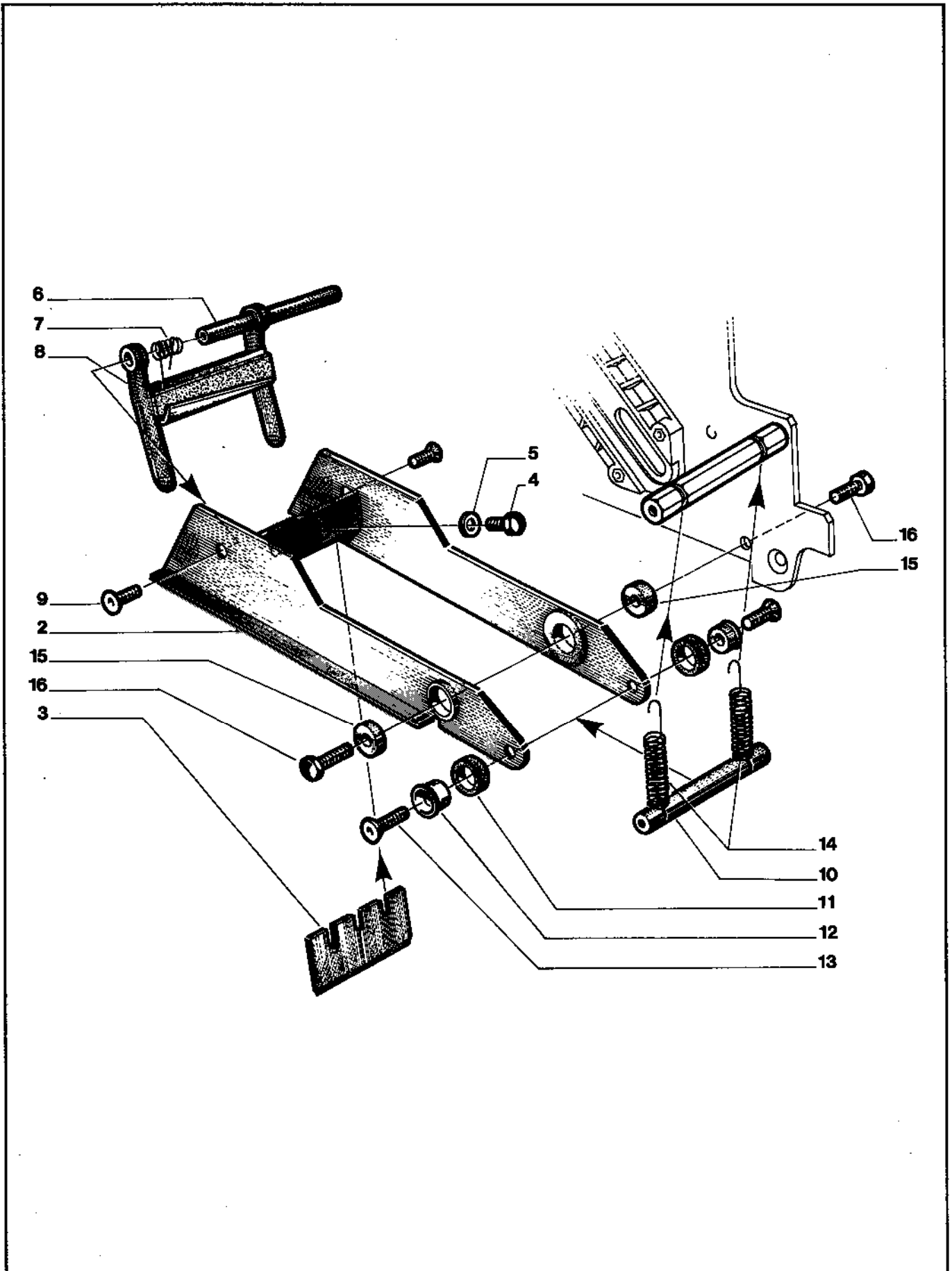

Figure 2569

**Figure 2569**

<b>Ref. No.</b>	<b>3M Part No.</b>	<b>Description</b>
2569-1	78-8060-8346-1	Cutting Lever Assembly
2569-2	78-8060-8259-6	Lever - Cutting
2569-3	78-8060-8419-6	Blade - 2,56 (65 mm)
2569-4	78-8060-8342-0	Screw - Hex Hd M5 x 8
2569-5	78-8060-8303-2	Washer - Plain M5, Metric
2569-6	78-8060-8265-3	Shaft - Felter 6 x 82
2569-7	78-8060-8275-2	Spring - Felter
2569-8	78-8060-8264-6	Support - Felter
2569-9	78-8060-8341-2	Screw - Flat M4 x 10
2569-10	78-8060-8276-0	Shaft - Spring, Cutting
2569-11	78-8017-9133-2	Spacer
2569-12	78-8060-8286-9	Support - Bumper
2569-13	78-8060-8333-9	Screw - Flat M5 x 20
2569-14	78-8060-8340-4	Spring - Cutting
2569-15	78-8060-8287-7	Spacer
2569-16	78-8060-8204-2	Screw - Hex Hd M6 x 12

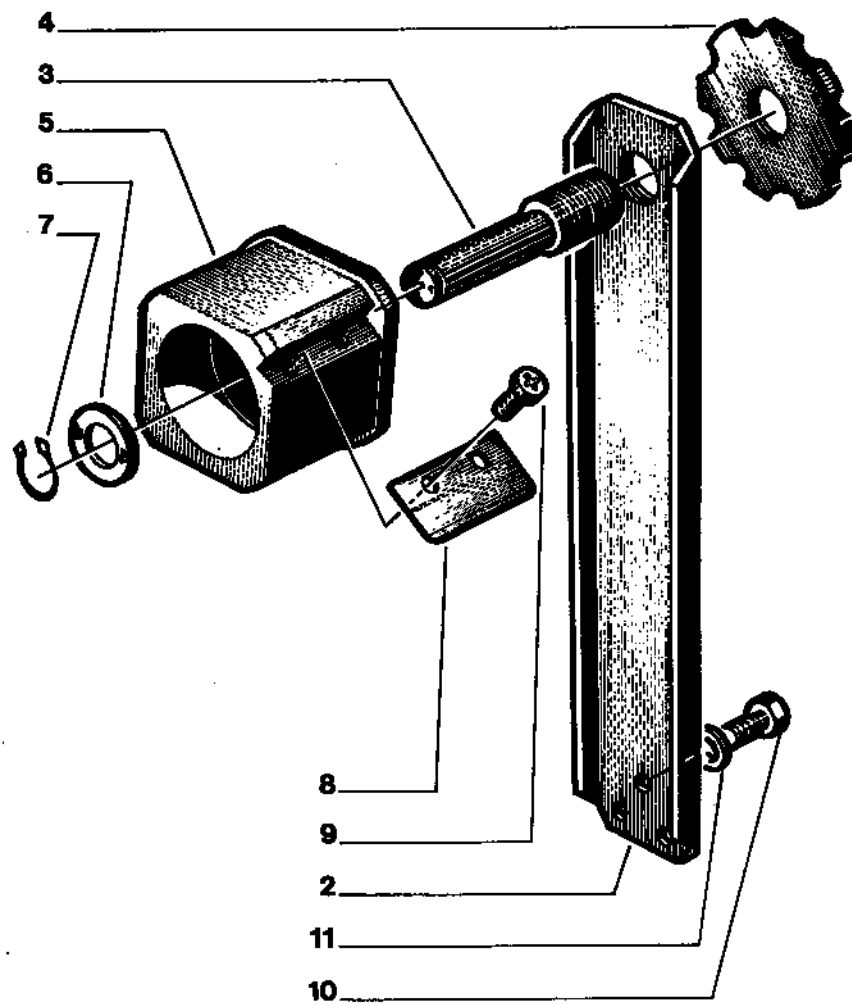

Figure 2570

**Figure 2570**

<b>Ref. No.</b>	<b>3M Part No.</b>	<b>Description</b>
2570-1	78-8060-8377-6	Coreholder Assembly
2570-2	78-8060-8347-9	Bracket
2570-3	78-8060-8350-3	Shaft - Coreholder
2570-4	78-8060-8349-5	Ring Nut
2570-5	78-8052-6749-5	Tape Drum Assembly
2570-6	78-8060-8364-4	Washer - Coreholder
2570-7	78-8060-8376-8	Ring - /14
2570-8	78-8060-8362-8	Spatula - Coreholder
2570-9	78-8060-8337-0	Screw - Self Tapping
2570-10	78-8060-8204-2	Screw - Hex Hd M6 x 12
2570-11	78-8060-8312-3	Washer - Flat M6

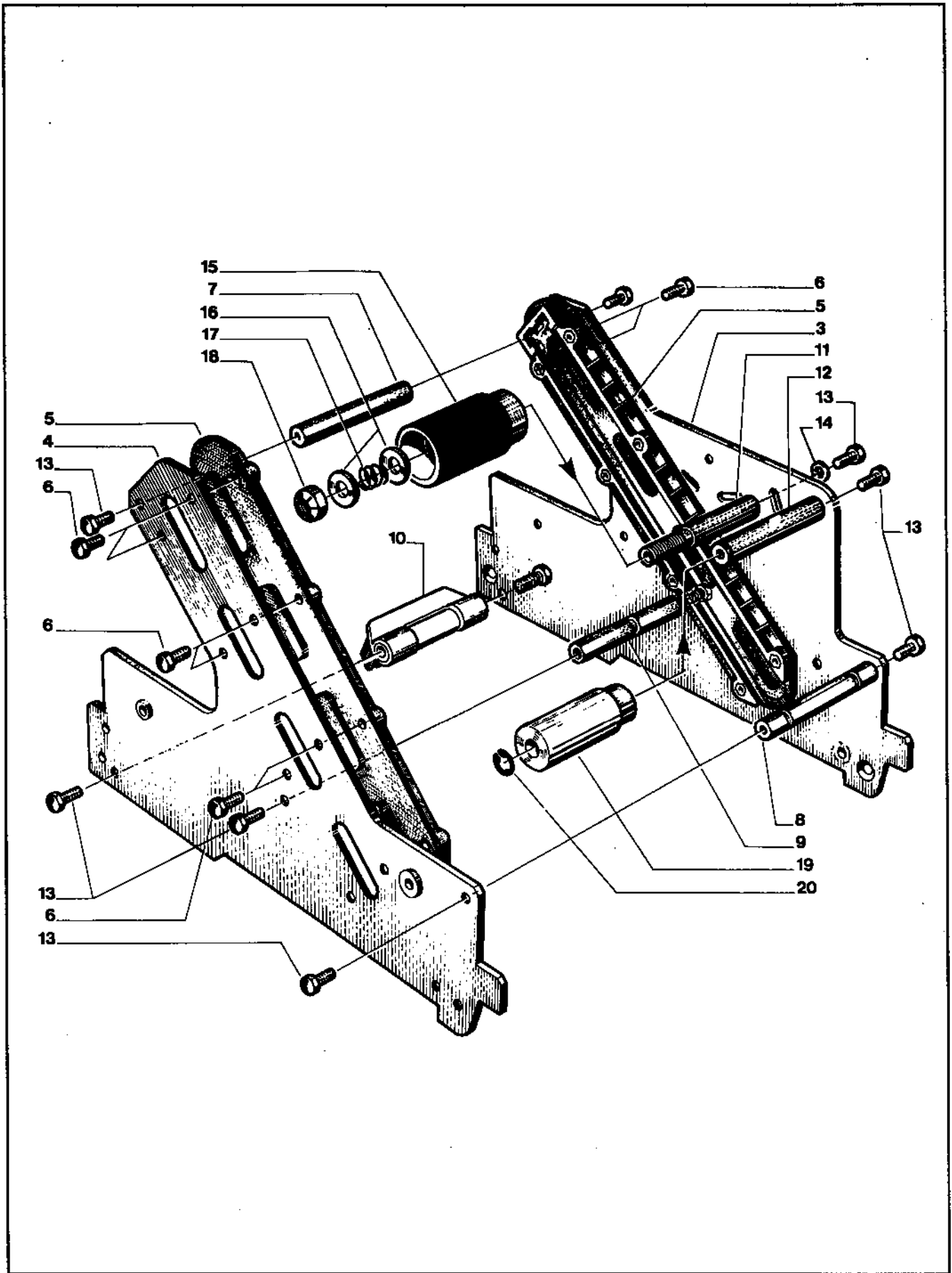

Figure 2571

**Figure 2571**

<b>Ref. No.</b>	<b>3M Part No.</b>	<b>Description</b>
2571-1	78-8060-8392-5	Frame Assembly - Right
2571-2	78-8060-8393-3	Frame Assembly - Left
2571-3	78-8060-8390-9	Frame - Right/Bottom
2571-4	78-8060-8378-4	Frame - Left/Bottom
2571-5	78-8060-8208-3	Guide - W/Nut
2571-6	78-8060-8205-9	Screw - Hex Hd M4 x 14
2571-7	78-8060-8193-7	Spacer - L90
2571-8	78-8060-8194-5	Spacer - Hex 10 x 90
2571-9	78-8060-8192-9	Spacer - Hex 10 x 90
2571-10	78-8060-8207-5	Brush Assembly
2571-11	78-8060-8200-0	Shaft - Roller
2571-12	78-8060-8202-6	Shaft - Idler Roller
2571-13	78-8060-8204-2	Screw - Hex Hd M6 x 12
2571-14	78-8060-8312-3	Washer - Flat M6
2571-15	78-8052-6606-7	Roller - Tension Bottom
2571-16	78-8060-8315-6	Washer - Friction
2571-17	78-8060-8354-5	Spring
2571-18	78-8060-8201-8	Nut - M10 x 1 NHT70
2571-19	78-8052-6569-7	Roller - Wrap
2571-20	26-1000-1613-3	Ring - Retaining 10DIN6799

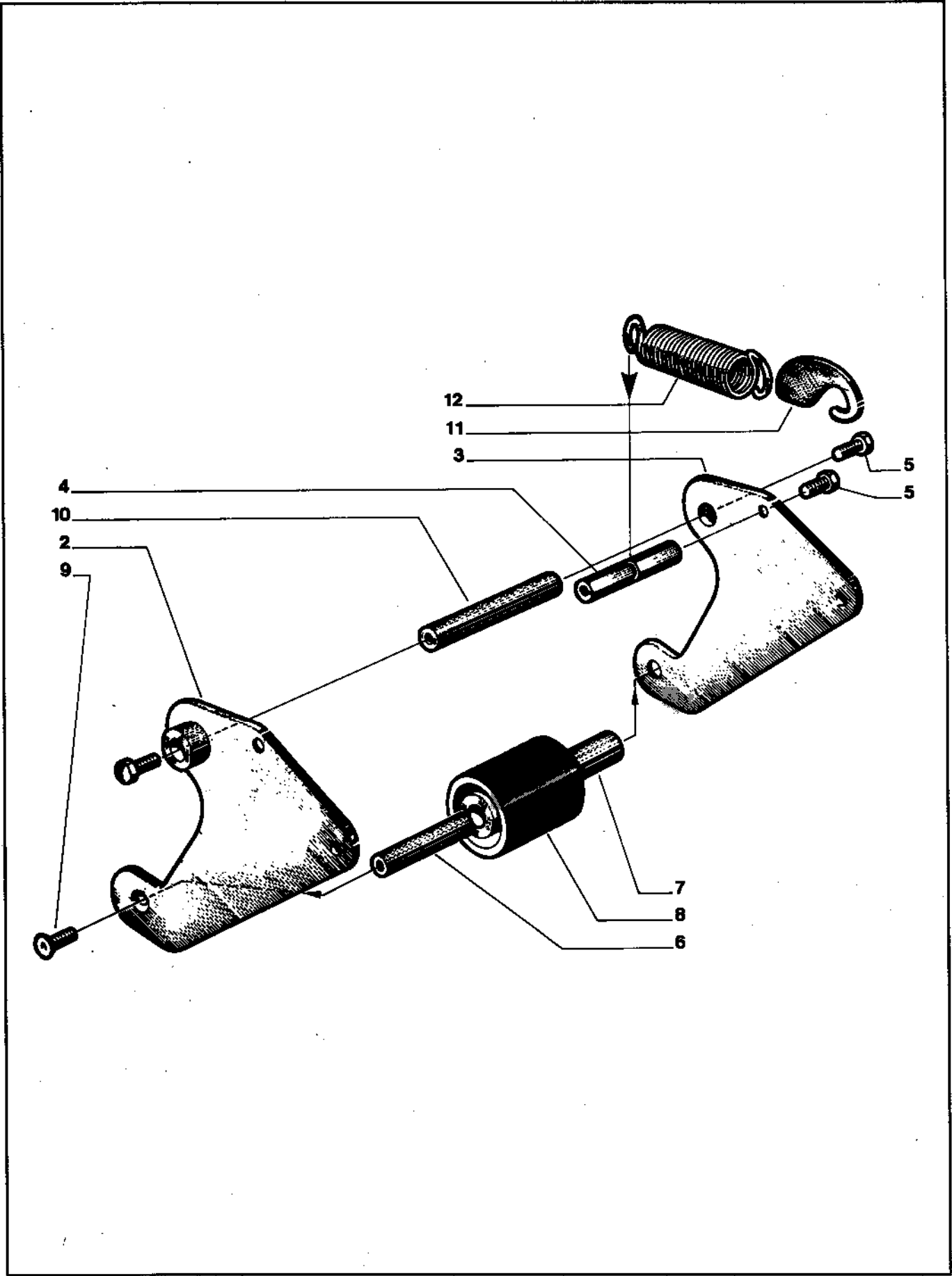

Figure 2572



**Figure 2572**

<b>Ref. No.</b>	<b>3M Part No.</b>	<b>Description</b>
2572-1	78-8060-8239-8	Exit Gr. Assembly
2572-2	78-8060-8226-5	Shoulder - Exit Right
2572-3	78-8060-8228-1	Shoulder - Exit Left
2572-4	78-8060-8229-9	Spacer - Hex 10 x 60
2572-5	78-8060-8204-2	Screw - Hex Hd M6 x 12
2572-6	78-8060-8217-4	Shaft - 10 x 60
2572-7	78-8052-6586-1	Bushing - Buffing Roller
2572-8	78-8057-6178-6	Roller - Buffing NM
2572-9	78-8060-8223-2	Screw - Flat Hd M6 x 12
2572-10	78-8060-8234-9	Shaft - 10 x 90
2572-11	78-8060-8238-0	Hock - Spring
2572-12	78-8060-8394-1	Spring - Main Bottom

**22A-S Case Sealer, Model 18900**  
**Replacement Parts Illustrations and Parts Lists**  
**Frame Assemblies**

1. Refer to **Frame Assemblies** figure to find all parts illustrations identified by figure numbers.
2. Refer to the figure or figures to determine the **individual parts** required and the parts reference number.
3. The **replacement parts list**, that follows each illustration, includes the part number and part description for the parts in the illustration.

**Note** - The complete description has been included for standard fasteners and some commercially available components. This has been done to allow obtaining these standard parts locally, should the customer elect to do so.

4. Refer to page 19 - "**Replacement Parts and Service Information**" of this manual for replacement parts ordering information.

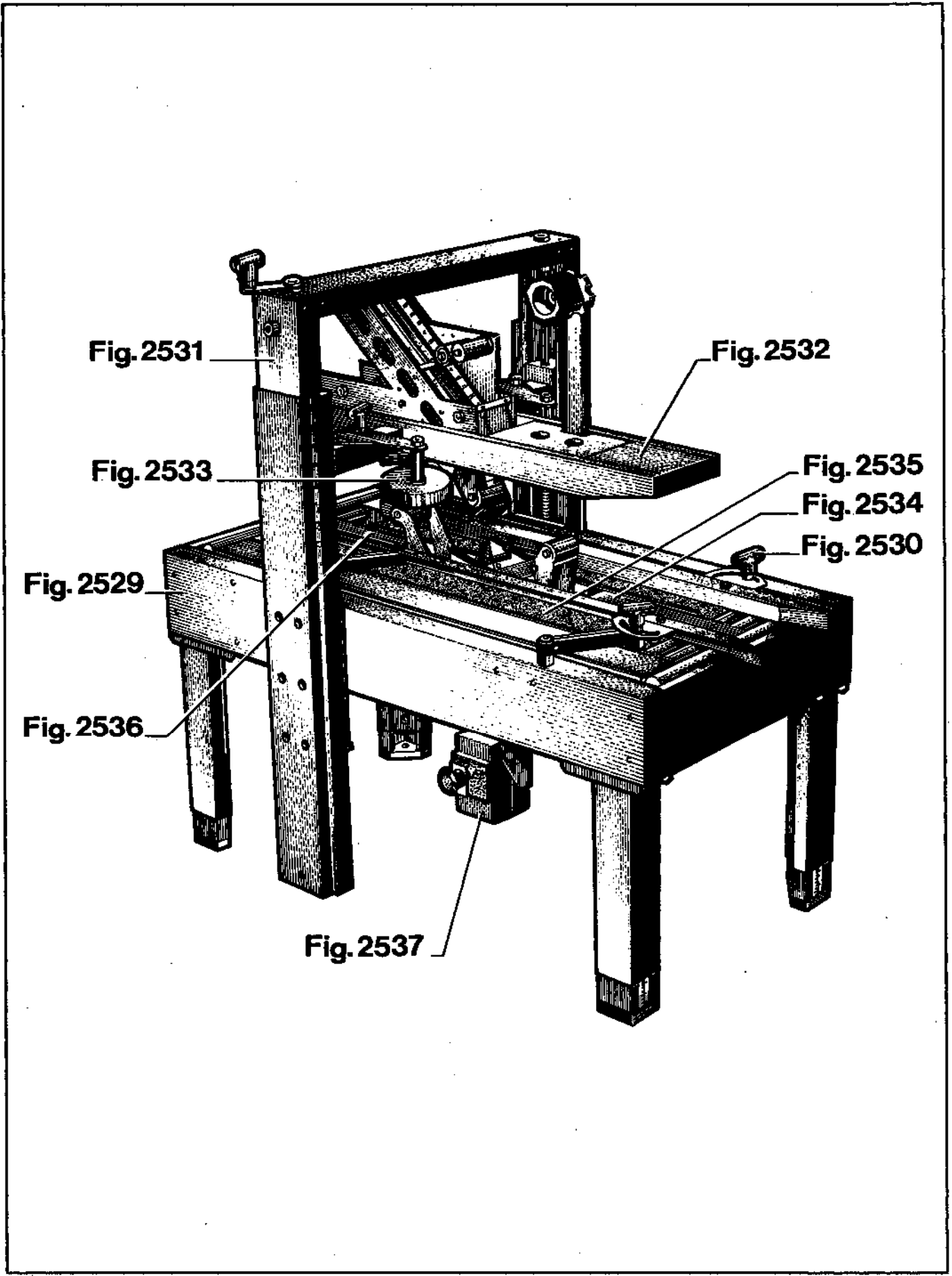

Frame Assembly

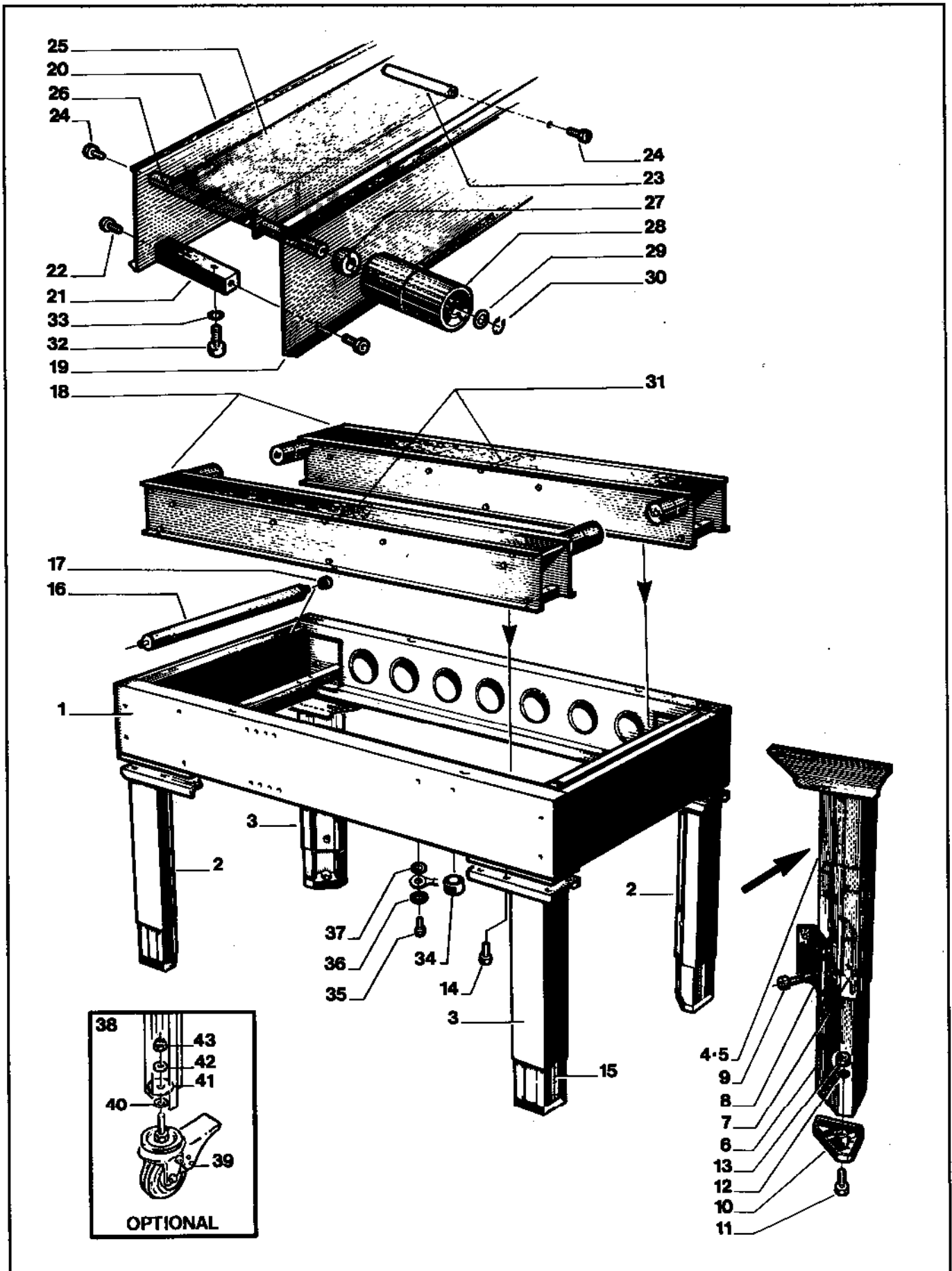

Figure 2529

**Figure 2529**

<b>Ref. No.</b>	<b>3M Part No.</b>	<b>Description</b>
2529-1	78-8060-8367-7	Bed - Conveyor
2529-2	78-8060-8403-0	Leg Assembly - Right
2529-3	78-8060-8402-2	Leg Assembly - Left
2529-4	78-8060-8365-1	Leg - Right
2529-5	78-8060-8366-9	Leg - Left
2529-6	78-8060-8355-2	Leg - Inner
2529-7	78-8060-8195-2	Clamp - Inner
2529-8	78-8060-8196-0	Clamp - Outer
2529-9	78-8060-8332-1	Screw - Soc Hd M8 x 16
2529-10	78-8052-6679-4	Pad - Foot
2529-11	78-8060-8319-8	Screw - Hex Hd M8 x 20
2529-12	78-8060-8335-4	Washer - M8
2529-13	78-8060-8320-6	Nut - Self Locking M8
2529-14	78-8060-8307-3	Screw - Soc Hd M8 x 20
2529-15	78-8052-6680-2	Label - Height
2529-16	78-8060-8383-4	Roller - Conveyor
2529-17	78-8052-6668-7	Snap - Roller
2529-18	78-8060-8384-2	Conveyor Bed Assembly
2529-19	78-8060-8218-2	Side Plate
2529-20	78-8060-8219-0	Side Plate
2529-21	78-8060-8252-1	Block Mounting
2529-22	78-8060-8306-5	Screw - Soc Hd M5 x 10
2529-23	78-8060-8253-9	Spacer
2529-24	78-8060-8300-8	Screw - Hex Hd M5 x 10, Metric
2529-25	78-8052-6662-0	Conveyor Bed
2529-26	78-8060-8254-7	Spacer
2529-27	78-8052-6672-9	Spacer
2529-28	78-8052-6667-9	Roller
2529-29	78-8060-8308-1	Washer - Plain M8, Metric
2529-30	78-8060-8338-8	Ring - Special M8
2529-31	78-8060-8255-4	Spacer
2529-32	78-8060-8298-4	Screw - Soc Hd M6 x 12
2529-33	78-8060-8312-3	Washer - Flat M6
2529-34	78-8060-7758-8	Fairlead - /20
2529-35	78-8060-8325-5	Screw - Hex Hd M5 x 12
2529-36	78-8060-8303-2	Washer - Plain M5, Metric
2529-37	78-8060-8401-4	Washer - Special
2529-38	78-8060-8404-8	Caster Assembly - /80
2529-39	78-8060-8061-6	Caster - /80
2529-40	78-8060-8405-5	Spacer - Caster
2529-41	78-8060-8406-3	Washer - /12/45 - 5 x 4
2529-42	78-8060-8304-0	Washer - Flat M12
2529-43	78-8060-8407-1	Nut - Self Locking M12

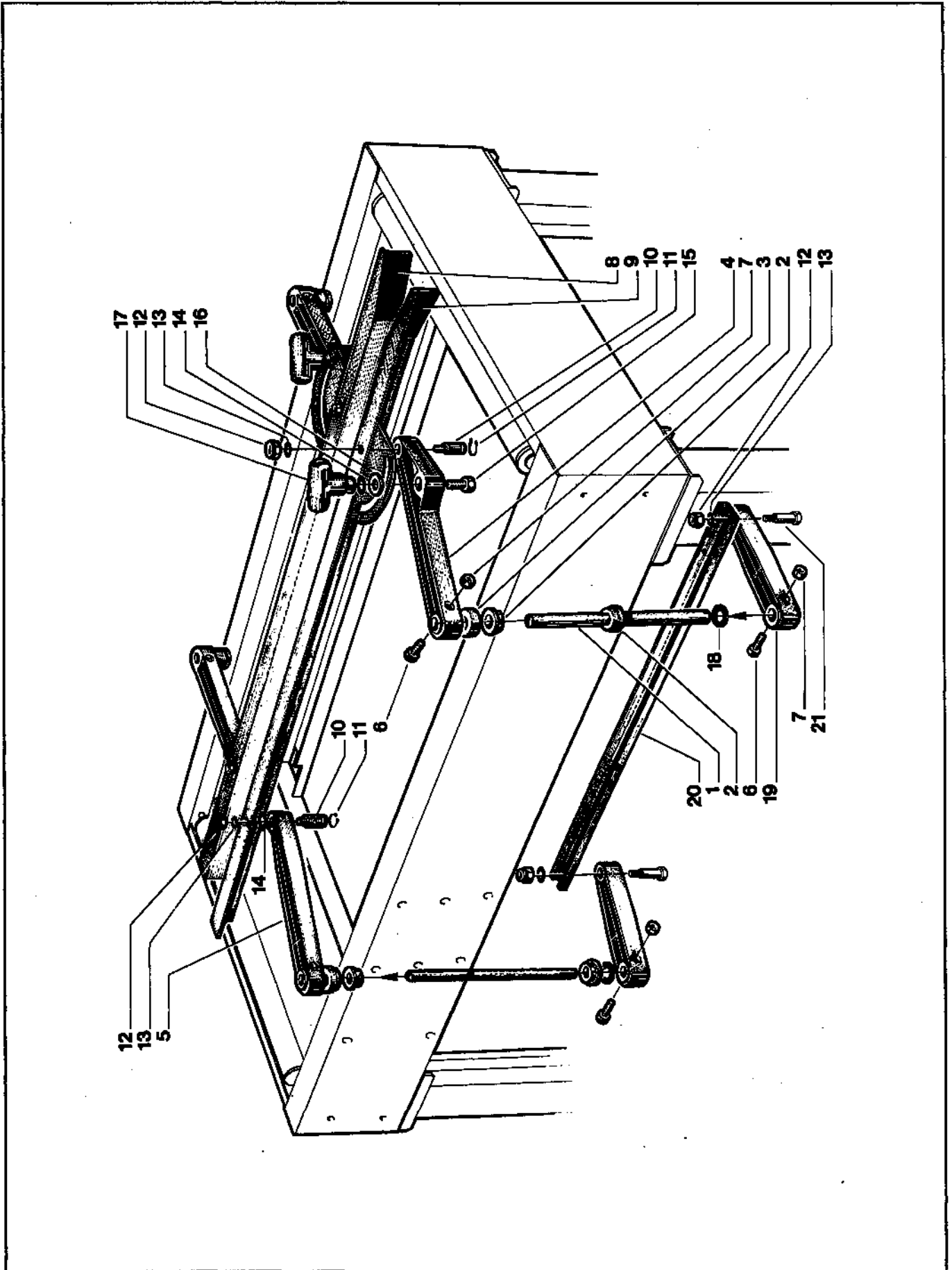

Figure 2530

**Figure 2530**

<b>Ref. No.</b>	<b>3M Part No.</b>	<b>Description</b>
2530-1	78-8060-8257-0	Shaft
2530-2	78-8052-6687-7	Sleeve
2530-3	78-8052-6692-7	Sleeve
2530-4	78-8052-6691-9	Arm - Guide
2530-5	78-8052-6682-8	Arm - Guide
2530-6	78-8060-8311-5	Screw - Soc Hd M6 x 20
2530-7	78-8060-8288-5	Nut - Hex M6, Metric
2530-8	78-8060-8356-0	Guide - Right
2530-9	78-8060-8357-8	Guide - Left
2530-10	78-8060-8256-2	Stud - Guide
2530-11	78-8060-8339-6	Ring - Special M10
2530-12	78-8060-8318-0	Nut - Locking M6
2530-13	78-8060-8312-3	Washer - Flat M6
2530-14	78-8060-8315-6	Washer - Friction
2530-15	78-8060-8329-7	Screw - Hex Hd M10 x 35
2530-16	78-8060-8348-7	Washer - Dented
2530-17	78-8060-8375-0	Knob
2530-18	78-8060-8304-0	Washer - Flat M12
2530-19	78-8052-6688-5	Arm - Guide
2530-20	78-8060-8206-7	Link - Guide
2530-21	78-8060-8285-1	Idler Screw

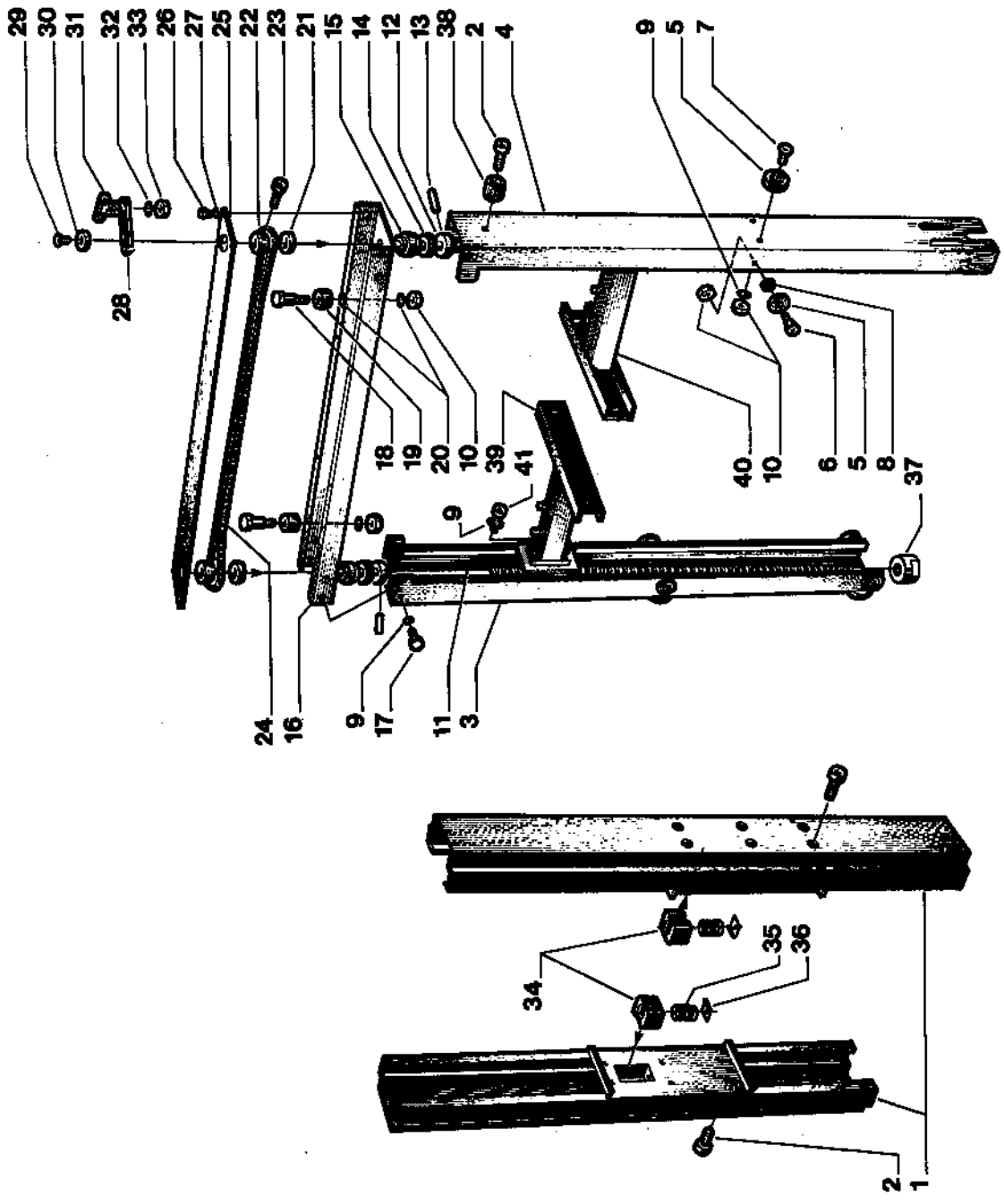

Figure 2531



Figure 2531

Ref. No.	3M Part No.	Description
2531-1	78-8060-8363-6	Column - Outer
2531-2	78-8060-8307-3	Screw - Soc Hd M8 x 20
2531-3	78-8060-8385-9	Inner Column Assembly
2531-4	78-8060-8368-5	Column - Inner
2531-5	78-8054-8617-8	Bearing - Special
2531-6	78-8060-8241-4	Screw - Bearing Shoulder
2531-7	78-8060-8272-9	Screw - Special
2531-8	78-8060-8274-5	Spacer
2531-9	78-8060-8312-3	Washer - Flat M6
2531-10	78-8060-8318-0	Nut - Locking M6
2531-11	78-8060-8270-3	Lead Screw
2531-12	78-8060-8271-1	Collar
2531-13	78-8060-8343-8	Pin
2531-14	78-8054-8584-0	Spacer
2531-15	78-8054-8583-2	Bushing
2531-16	78-8060-8369-3	Chain - Housing
2531-17	78-8060-8295-0	Screw - Hex Hd M6 x 16, Metric
2531-18	78-8060-8285-1	Idler - Screw
2531-19	78-8054-8575-8	Idler - Roller
2531-20	78-8060-8296-8	Washer - M6
2531-21	78-8060-8260-4	Spacer
2531-22	78-8060-8251-3	Sprocket
2531-23	78-8060-8310-7	Screw - Soc Hd M4 x 25
2531-24	78-8060-8344-6	Chain
2531-25	78-8060-8216-6	Cover - Chain
2531-26	78-8060-8337-0	Screw - Self Tapping
2531-27	78-8060-8297-6	Washer - Plain 5 mm, Metric
2531-28	78-8060-8198-6	Lever - Knob
2531-29	78-8060-8299-2	Screw - Flat Soc Hd M6 x 16
2531-30	78-8060-8243-0	Washer - Special
2531-31	78-8060-8389-1	Crank
2531-32	78-8060-8294-3	Washer - Lock M6, Metric
2531-33	78-8060-8288-5	Nut - Hex M6, Metric
2531-34	78-8054-8571-7	Plastic Nut
2531-35	78-8060-8353-7	Spring
2531-36	78-8054-8970-1	Bed Plate - Spring
2531-37	78-8060-8284-4	Special Nut
2531-38	78-8060-8273-7	Stop
2531-39	78-8060-8360-2	Head Support - Right
2531-40	78-8060-8361-0	Head Support - Left
2531-41	78-8060-8311-5	Screw - Soc Hd M6 x 20

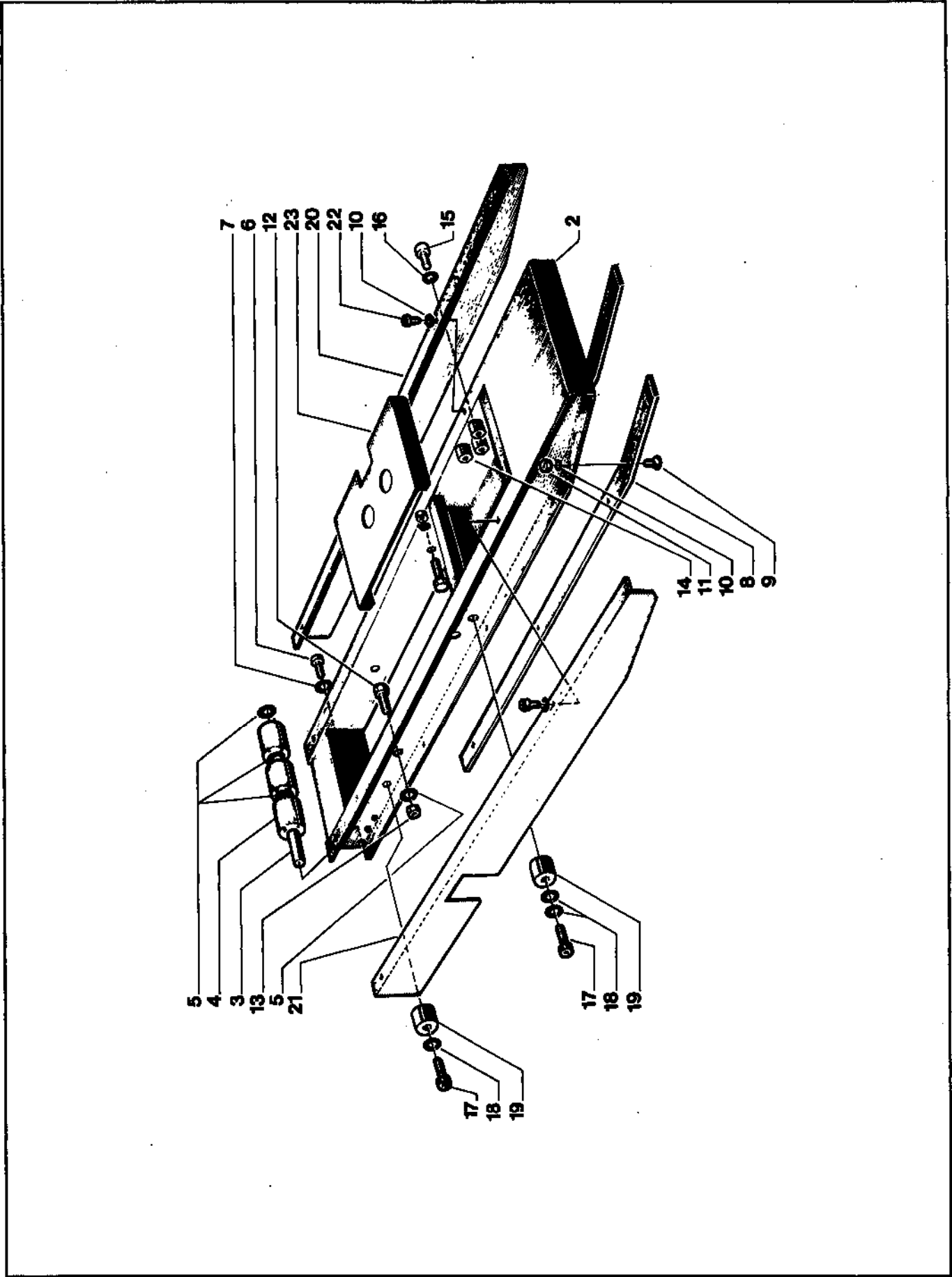

Figure 2532

**Figure 2532**

<b>Ref. No.</b>	<b>3M Part No.</b>	<b>Description</b>
2532-1	78-8060-8388-3	Top Hd Support Assembly
2532-2	78-8060-8359-4	Housing - Upper
2532-3	78-8060-8266-1	Shaft
2532-4	78-8060-7693-7	Roller 32 x 38
2532-5	78-8060-8308-1	Washer - Plain M8, Metric
2532-6	78-8060-8325-5	Screw - Hex Hd M5 x 12
2532-7	78-8060-8303-2	Washer - Plain M5, Metric
2532-8	78-8052-6699-2	Slide
2532-9	78-8060-8309-9	Screw - Flat Hd M4 x 15
2532-10	78-8060-8297-6	Washer - Plain 4 mm, Metric
2532-11	78-8060-8321-4	Nut - Plastic Insert M4
2532-12	78-8060-8323-0	Screw - M8 x 16
2532-13	78-8060-8289-3	Nut - Hex M8, Metric
2532-14	78-8060-8263-8	Spacer
2532-15	78-8060-8290-1	Screw - Soc Hd M6 x 25
2532-16	78-8060-8312-3	Washer - Flat M6
2532-17	78-8060-8311-5	Screw - Soc Hd M6 x 20
2532-18	78-8060-8296-8	Washer - M6
2532-19	78-8060-8245-5	Spacer
2532-20	78-8060-8222-4	Cover - Right
2532-21	78-8060-8221-6	Cover - Left
2532-22	78-8060-8337-0	Screw - Self Tapping
2532-23	78-8060-8227-3	Cover

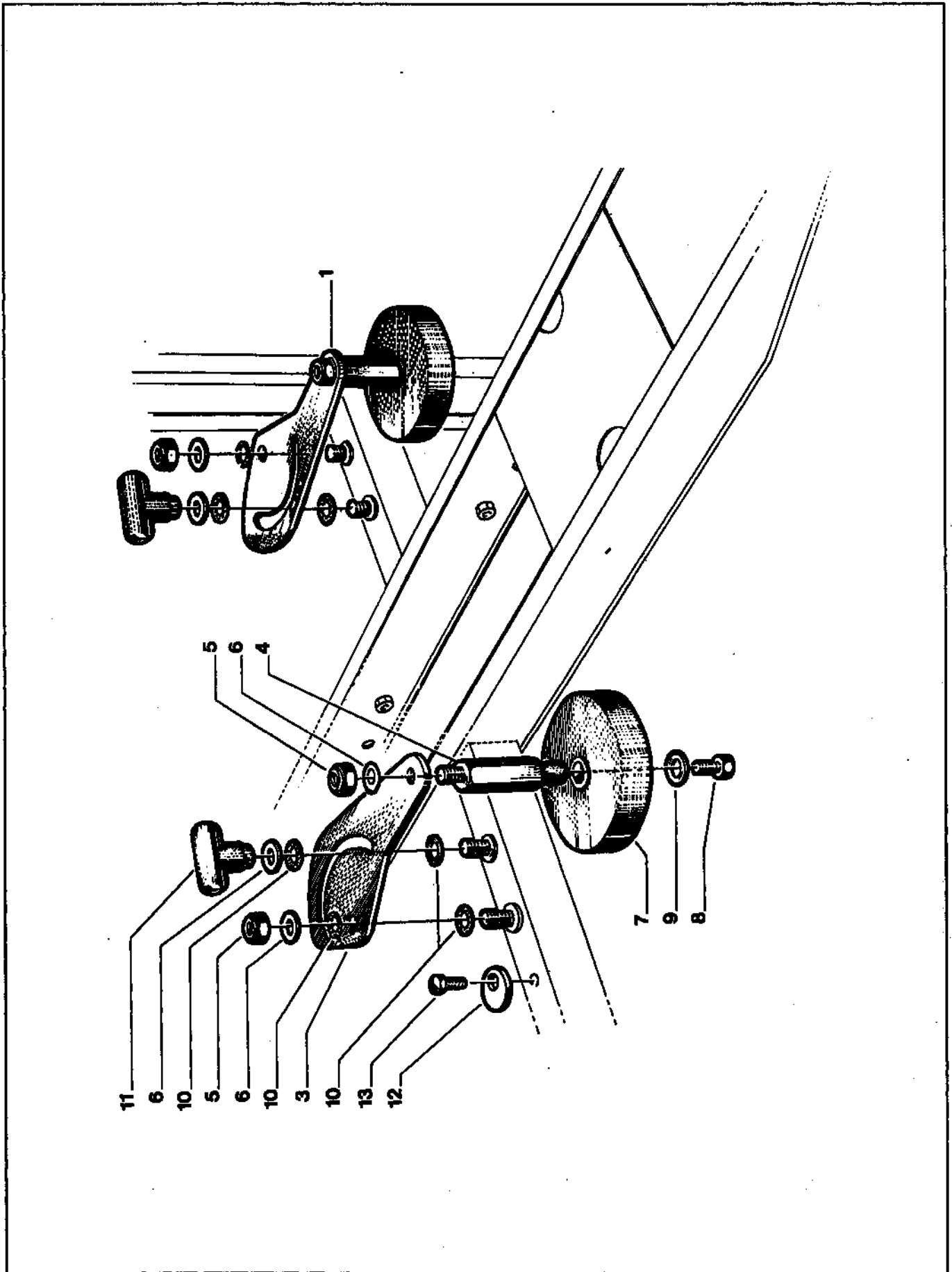

Figure 2533

**Figure 2533**

<b>Ref. No.</b>	<b>3M Part No.</b>	<b>Description</b>
2533-1	78-8060-8386-7	Side Roller Assembly - Right
2533-2	78-8060-8387-5	Side Roller Assembly - Left
2533-3	78-8060-8199-4	Plate - Mounting
2533-4	78-8060-8258-8	Stud - Mounting
2533-5	78-8060-8328-9	Nut - Hex Plastic Insert M10
2533-6	78-8060-8315-6	Washer - Friction
2533-7	78-8054-8974-3	Pressure Roller
2533-8	78-8060-8323-0	Screw - M8 x 16
2533-9	78-8060-8262-0	Washer - Special
2533-10	78-8017-9074-8	Washer - Nylon 15 mm
2533-11	78-8060-8375-0	Knob
2533-12	78-8060-8236-4	Cam - Pressure Roller Stops
2533-13	78-8060-8300-8	Screw - Hex Hd M5 x 10, Metric

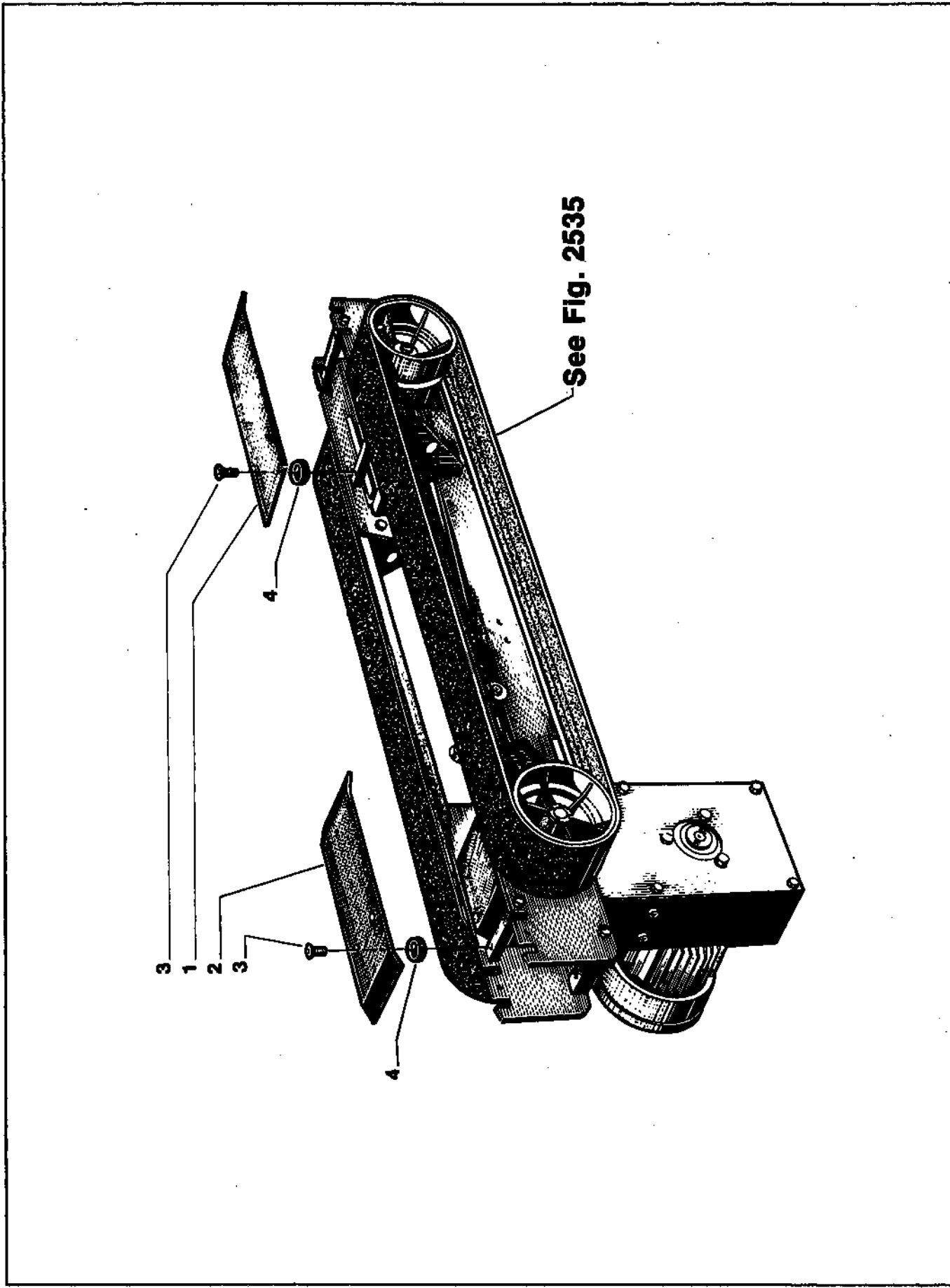

Figure 2534

**Figure 2534**

<b>Ref. No.</b>	<b>3M Part No.</b>	<b>Description</b>
2534-1	78-8052-6721-4	Plate - Center, Front
2534-2	78-8052-6723-0	Plate - Center, Rear
2534-3	78-8060-8327-1	Screw - Flat Hd M5 x 16
2534-4	78-8060-8267-9	Spacer

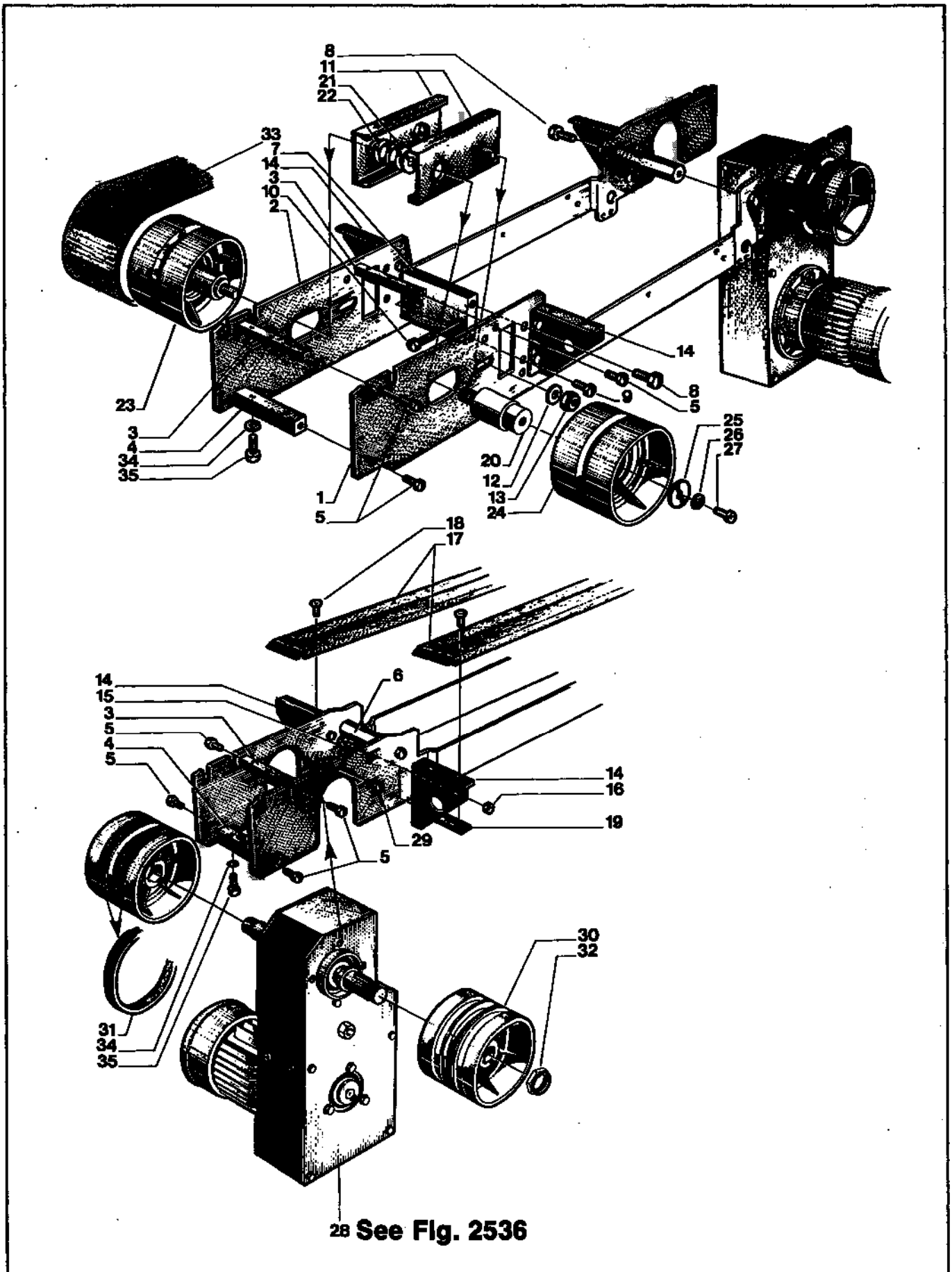

Figure 2535



**Figure 2535**

<b>Ref. No.</b>	<b>3M Part No.</b>	<b>Description</b>
2535-1	78-8060-8210-9	Side Plate
2535-2	78-8060-8211-7	Lower Main Plate - Left
2535-3	78-8060-8268-7	Spacer - 10 x 10 x 90 mm
2535-4	78-8060-8261-2	Bar - Special
2535-5	78-8060-8292-7	Screw - Hex Hd M6 x 12, Metric
2535-6	78-8060-8242-2	Spacer - Hexagonal
2535-7	78-8052-6705-7	Block - Spacer
2535-8	78-8060-8334-7	Screw - Hex Hd M10 x 16
2535-9	78-8060-8295-0	Screw - Hex Hd M6 x 16, Metric
2535-10	78-8060-8317-2	Screw - Hex Hd, M8 x 40
2535-11	78-8060-8358-6	Roller - Bracket
2535-12	78-8060-8315-6	Washer - Friction
2535-13	78-8060-8328-9	Nut - Hex Plastic Insert M10
2535-14	78-8060-8190-3	Bracket
2535-15	78-8060-8325-5	Screw - Hex Hd M5 x 12
2535-16	78-8060-8293-5	Nut - Hex M5, Metric
2535-17	78-8060-8188-7	Guide - Drive Belt
2535-18	78-8060-8327-1	Screw - Flat Hd M5 x 16
2535-19	78-8060-8197-8	Bracket
2535-20	78-8060-8246-3	Shaft - Roller
2535-21	78-8060-8291-9	Nut - M12, Metric
2535-22	78-8060-8247-1	Washer - Metric
2535-23	78-8060-8379-2	Idler Roller Assembly
2535-24	78-8052-6710-7	Roller - Idler
2535-25	78-8060-8248-9	Washer - Special
2535-26	78-8060-8294-3	Washer - Lock M6, Metric
2535-27	78-8060-8331-3	Screw - Soc Hd M6 x 16
2535-28	78-8060-8391-7	Gear Box Assembly - W/O Motor
2535-29	78-8060-8324-8	Screw - Hex Hd M5 x 16
2535-30	78-8060-8371-9	Roller - Drive
2535-31	78-8052-6713-1	Ring - Polyurethane
2535-32	78-8060-8351-1	Nut - Self Locking M20 x 1
2535-33	78-8052-6722-2	Belt - Drive
2535-34	78-8060-8312-3	Washer - Flat M6
2535-35	78-8060-8298-4	Screw - Soc Hd M6 x 12

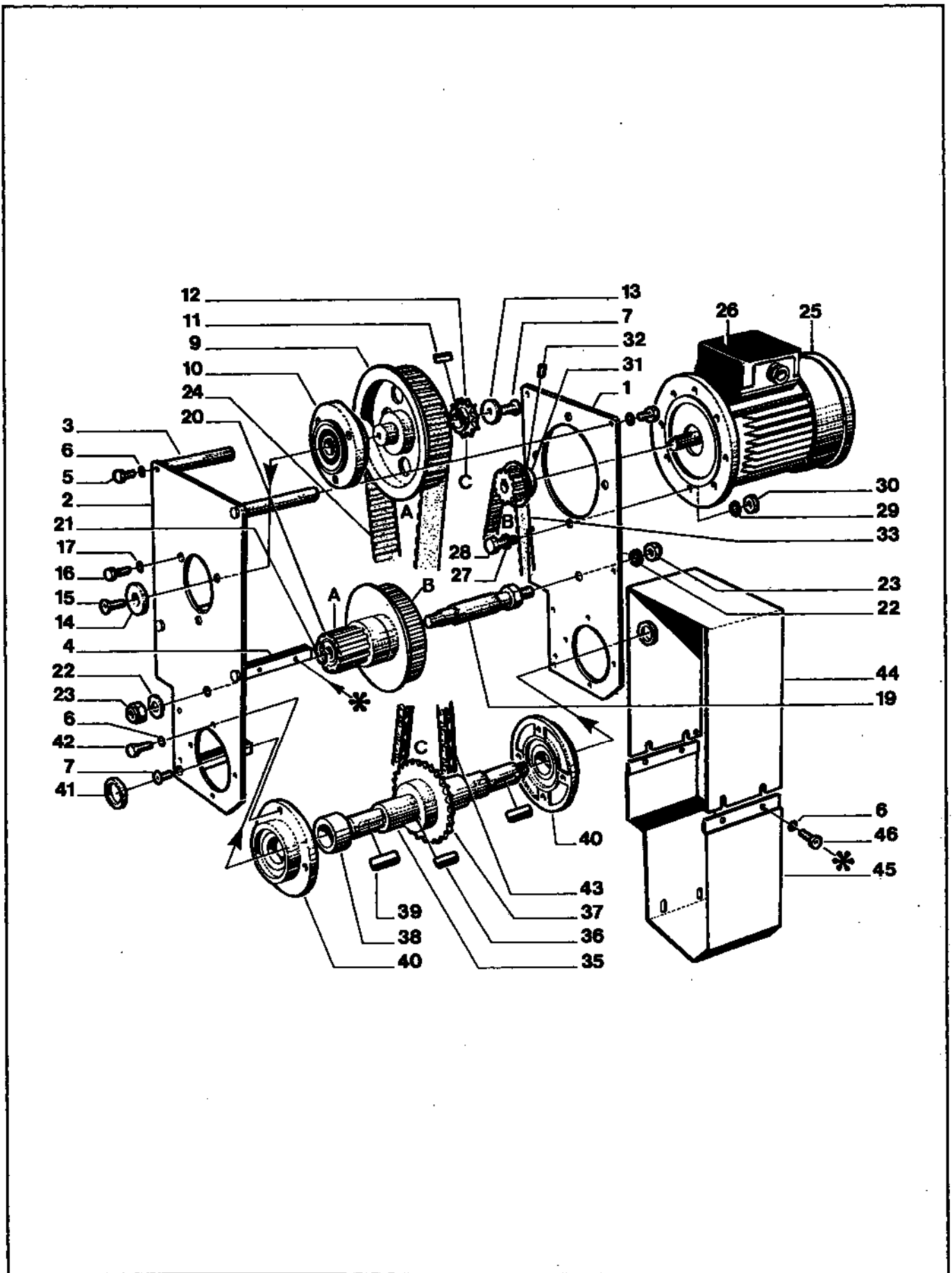

Figure 2536

Figure 2536

Ref. No.	3M Part No.	Description
2536-1	78-8060-8230-7	Frame - Right Side
2536-2	78-8060-8231-5	Frame - Left Side
2536-3	78-8060-8282-8	Spacer
2536-4	78-8060-8281-0	Spacer
2536-5	78-8060-8325-5	Screw - Hex Hd M5 x 12
2536-6	78-8060-8303-2	Washer - Plain M5, Metric
2536-7	78-8060-8330-5	Screw - Flat Soc Hd M5 x 12
2536-8	78-8060-8380-0	Gear Box Pulley Assembly
2536-9	78-8060-8372-7	Pulley Timing Belt
2536-10	78-8060-8373-5	Housing - Bearing
2536-11	78-8060-8336-2	Key - 4 x 4 x 10 mm
2536-12	78-8060-8279-4	Sprocket - 3/8 Pitch, 11 Teeth
2536-13	78-8060-8269-5	Washer - 5,5/20 x 4
2536-14	78-8060-8243-0	Washer - Special
2536-15	78-8060-8299-2	Screw - Flat Soc Hd M6 x 16
2536-16	78-8060-8301-6	Screw - Hex Hd M6 x 20, Metric
2536-17	78-8060-8296-8	Washer - M6
2536-18	78-8060-8381-8	Pulley Assembly
2536-19	78-8060-8280-2	Shaft Timing Pulley
2536-20	78-8060-8370-1	Reducer - Pulley
2536-21	78-8060-8314-9	E-Ring - 10 mm
2536-22	78-8060-8308-1	Washer - Plain M8, Metric
2536-23	78-8060-8320-6	Nut - Self Locking M8
2536-24	78-8057-5808-9	Timing Belt - 187L100
2536-25	78-8060-8408-9	Motor - 115V, 60HZ, S-Phase, B14
2536-26	78-8060-7880-0	Eyelet - Terminal /4 Red
2536-27	78-8060-8335-4	Washer - M8
2536-28	78-8060-8302-4	Screw - Hex Hd M8 x 25
2536-29	78-8060-8302-4	Lockwasher - M8 Screw
2536-30	78-8060-8289-3	Nut - Hex M8, Metric
2536-31	78-8060-8283-6	Pulley - Timing 11 Teeth
2536-32	78-8060-8326-3	Screw - Set M5 x 6
2536-33	78-8057-5724-8	Timing Belt - 187L050 Boran
2536-34	78-8060-8382-6	Drive Shaft Assembly
2536-35	78-8060-8352-9	Shaft - Drive
2536-36	78-8060-8316-4	Key - 6 x 6 x 20 mm
2536-37	78-8060-8277-8	Sprocket - 3/8 Pitch, 28 Teeth
2536-38	78-8060-8278-6	Bushing
2536-39	78-8060-8313-1	Key - M5 x 5 x 30 mm
2536-40	78-8060-8374-3	Housing - Bearing
2536-41	78-8060-8244-8	Washer - /20,5 mm
2536-42	78-8060-8324-8	Screw - Hex Hd M5 x 16
2536-43	78-8060-8345-3	Chain - 3/8 Pitch, 57 Pitch Long
2536-44	78-8060-8233-1	Cover - Top
2536-45	78-8060-8232-3	Cover - Bottom
2536-46	78-8060-8322-2	Screw - Soc Hd M5 x 12

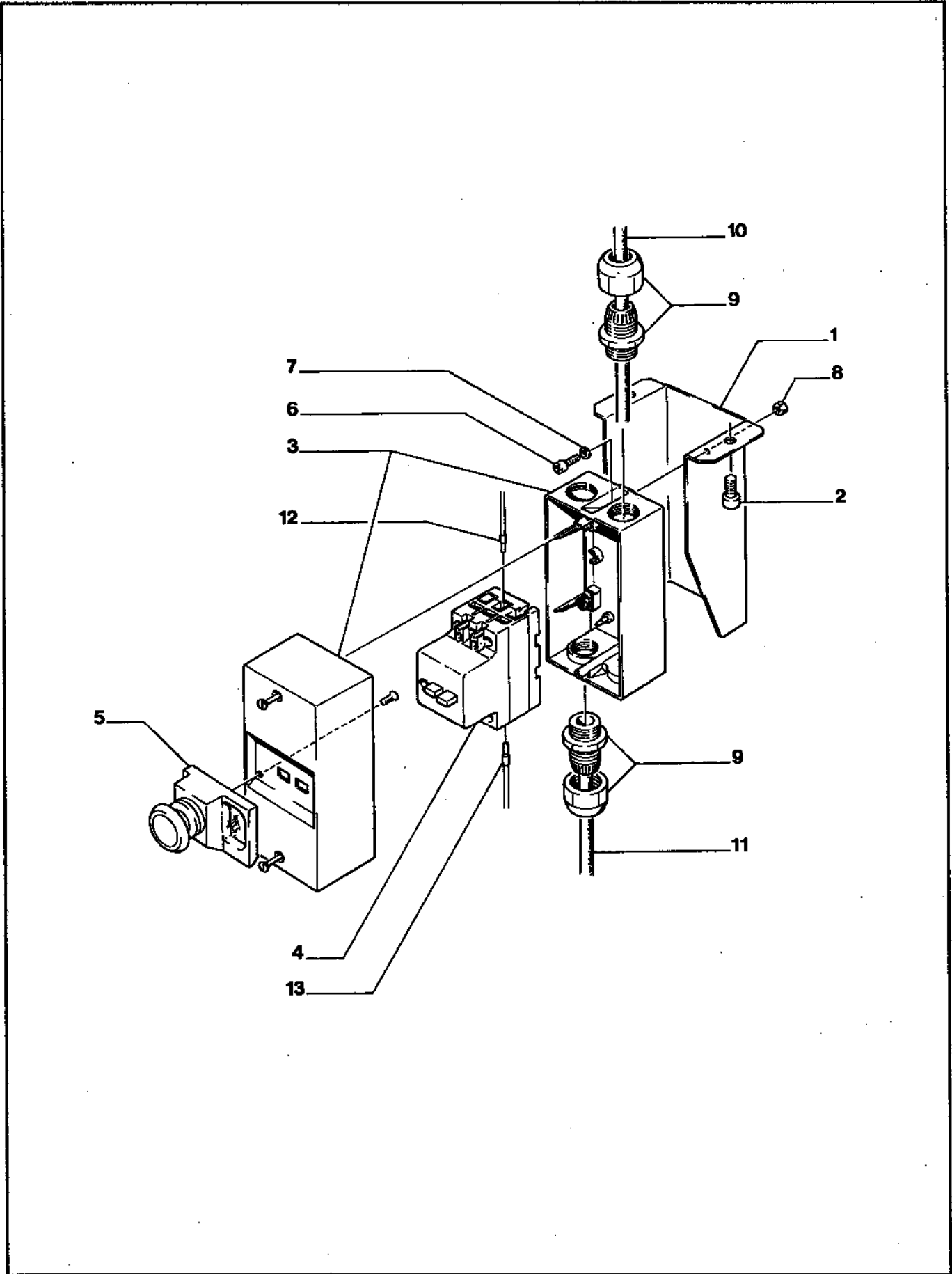

Figure 2537

**Figure 2537**

<b>Ref. No.</b>	<b>3M Part No.</b>	<b>Description</b>
2537-1	78-8060-8409-7	Support - Switch
2537-2	78-8060-8332-1	Screw - Soc Hd M8 x 16
2537-3	78-8060-8410-5	Box - Switch
2537-4	78-8060-8411-3	Switch - PKZM 1-2,4-4,0A
2537-5	78-8060-8412-1	Emergency Stop
2537-6	78-8060-8413-9	Screw - Soc Hd M4 x 12
2537-7	78-8060-8297-6	Washer - Plain 4 mm, Metric
2537-8	78-8060-8414-7	Nut - M4
2537-9	78-8057-5807-1	Cord Grip
2537-10	78-8060-8053-3	Cable - 3 x 1,5 5MT.5 x MF
2537-11	78-8028-7909-4	Power Cord
2537-12	78-8060-7637-4	Plug - Terminal, Wire /1,5
2537-13	78-8060-8415-4	Plug - Terminal, Wire /2,5

# 3M Parts Order Form

Form 26989 - 3 - D

Mail To: Dispenser Parts  
241 Venture Drive  
Amery, WI 54001

Fax or Call: 715-268-8126 (Wisc.)  
800-344-9883 (Outside Wisc.)  
FAX# 715-268-8153

P.O. No.	Date	Catalog No.	Phone No. (Including Area Code)	Customer Name
Attn.	Model No.	Serial No.		
Ship To		Charge To		
Via		Special Instructions		
Tax Exempt No.				

FAX Your Order For Faster Service FAX No. 715-268-8153

Qty.	Part Number	Description	Price
1.			
2.			
3.			
4.			
5.			
6.			
7.			
8.			
9.			

Please Print

Signature

Ship Via Air At Customer Expense

\$25.00 Minimum Order

