



BS-9101

1-2 PERSON SAUNA

OWNER'S MANUAL

BEAUTY & SAUNA

CONNECTION

FOR **INDOOR** USE ONLY

120VAC 15 AMP DEDICATED CIRCUIT

Enjoy Health And
Beauty In Your Life!

Sauna: the European secret for youthful vitality, now enjoy it for yourself!

Carefully and thoroughly read this manual before using the sauna for the first time. We recommend

keeping this manual for regular review and future reference.

Congratulations on your purchase of a Far Infra-Red (FIR) Dry Sauna from Keys Backyard. Please take a moment to read through some of the features and benefits of your new sauna. And remember to always consult your physician before beginning any sauna therapy program.

REV.A

HOW IT WORKS – Your sauna uses ceramic rods to produce beneficial infrared rays. This means that a metallic filament inside the ceramic has an electrical current pass through it. The filament heats the ceramic surrounding it, and the ceramic rod emits Far Infra-Red rays.

WHAT ARE FAR INFRARED RAYS – Infrared is an invisible band of light that warms objects without warming the air between them. These are the beneficial rays that our Sun produces, helping to warm our skin with direct sunlight even on a cold day. With our ceramic emitters up to 95% of the energy produced is transformed into Far Infra-Red rays with a wavelength of 5 to 17 microns. The Sun produces Far Infra-Red rays at 9.4 microns.

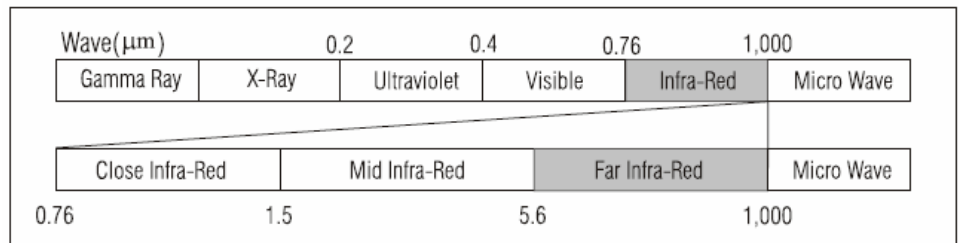

ARE INFRARED RAYS SAFE – Infrared rays are essential to almost every form of life on our planet. In addition to helping warm a person, they also help the body function better on a cellular level. The technology is so safe that it has been used for years in hospital delivery rooms to help newborn babies achieve an acceptable body temperature.

HOW TO USE YOUR SAUNA – Turn the sauna on and set the temperature to 140 degrees. You will want to wear a minimal amount of clothing into the sauna as some materials will absorb the infrared rays. Some people prefer to have some water with them to help replace the water that will be lost through perspiration. After about 5 minutes your sauna is ready to use. **REMEMBER** – your sauna is NOT a hot box. The infrared emitters are designed to heat you, not the air inside the box. The temperature gauge is there merely as a guide for your enjoyment and safety.

REMEMBER:
Your sauna is NOT a hot box. The infrared emitters are designed to heat you, not the air inside the box.

NOT A HOT BOX – When people hear the word sauna they typically think of a steam sauna where high temperatures and high humidity induce a person to sweat. In our example, a steam sauna is similar to a conventional oven. It cooks your food by heating it to extremely high temperatures. An infrared sauna is more like a microwave oven – it produces energy which warms the food and excites the water molecules inside the food to bake it. Your infrared sauna produces energy that will warm your body and cause the desired reactions without having to reach extremely high (and uncomfortable) temperatures inside the unit. Because of the infrared rays produced, sweating inside an infrared sauna will start at much lower temperatures than under normal conditions.

TEMPERATURE – The key to your infrared sauna is to keep the unit working the entire time you are inside. Working is defined as having a current sent through the filament, which thus produces infrared rays. If you wait until your sauna approaches or reaches its peak capacity of 140 degrees, the unit will only “work” (emitted infrared rays) when the temperature drops below 140, which means that you will only intermittently be receiving the beneficial infrared rays. The temperature gauge and the timer are mandated safety features to make sure that someone does not overheat their body. There are no negative side effects to prolonged

exposure to infrareds outside of overheating.

WHAT WILL HAPPEN INSIDE – You will feel the heat being generated by the infrared emitters immediately. The wavelength of this heat will allow the rays to penetrate your skin and heat your body beneath the surface. This will excite the water molecules stored in the layer of fat just beneath your skin, and cause you to start to sweat. Most people tend to sweat after about 20 minutes, although this time period shortens with frequent sauna use. This sweat also allows the body to detoxify itself as the toxins it has eliminated from your blood stream and stored in your fat layer can now be brought to the surface of the skin with the sweat. The direct heat will also cause your blood vessels to dilate (increasing your circulation) and will increase your breathing and heart rate. Your body will also burn calories as it produces sweat. It is recommended that you drink water before, during and after your sauna to make sure you do not become dehydrated.

Be careful with what you take inside of your sauna with you. Some metals absorb the infrared rays and can become extremely hot during a sauna session.

AFTER THE SAUNA – It is recommended that you towel off after your sauna session. It is NOT recommended that you take a shower immediately after as the pores in your skin will be open and could potentially absorb anything in your water; but if you do shower, do not use soap – just rinse off.

CARE FOR YOUR SAUNA – Your sauna does not require a lot of care. If desired, you can wipe it down with water and a clean cloth. Do not use oils or cleaning chemicals, as these items will then be released next time you are in your sauna and could potentially cause you health issues.

BENEFITS OF YOUR SAUNA – Benefits of infrared therapy have been studied for several decades in Japan, Europe and recently in the US as well. Frequent users of infrared saunas have seen:

- Lowering of blood pressure
- Decrease of joint stiffness
- Weight Loss
- Lowering of blood sugar levels
- Increase in blood flow
- Lowering of cholesterol
- Lowering of triglycerides
- Relief of muscle spasms
- Pain Relief
- Increases extensibility of collagen tissue
- Assists in resolution of inflammatory infiltrates, edema and exudates
- Help with acne, eczema, psoriasis, burns and skin lesions and cuts
- Helps open wound heal quicker and with less scarring
- Improve skin tone and elasticity
- Breaks up cellulite
- Boosts immune system
- Helps reduce injuries when used for warming up muscles before stretching and exercising

DISCLAIMER – The infrared rays emitted by your infrared sauna is reputed to offer an astounding range of possible therapeutic benefits and effects in research conducted around the world. These benefits are presented a reference purposes only, and no implication of Infrared Saunas creating a cure for or treating any disease is implied nor should be inferred. If you have a health condition, are using prescription drugs or have acute joint problems, please consult your physician before beginning an infrared sauna therapy routine. Persons with surgical implants (metal pins, rods, artificial joints, silicone or other) typically do not experience

any adverse effects, but should also consult their surgeon before beginning infrared therapy.

< MANUAL INDEX >

Product Introduction

Parts Description

Assembly Instructions

Sauna Controls

Tips for Using Your Sauna

Safety Instructions

Safeguards for Your Sauna

Troubleshooting Guide

Certificate of Warranty

Product Introduction

The infrared sauna room is composed of a wood cabin, infrared heaters, and a control system. The wood cabin includes FRONT PANEL, BACK PANEL, LEFT PANEL, RIGHT PANEL, BENCH PANEL, BOTTOM PANEL, TOP PANEL and TOP COVER. Within the cabin are the infrared heaters, back protection, bench panel, and control panel. The control panel allows you to set the temperature and time, and turn the reading lamp on. An audio socket is located on the ceiling for plugging in accessories such as an MP3 player (not included) to enjoy music while you enjoy your sauna.

PARTS DESCRIPTION

A. FRONT PANEL (SEE FIGURE 1)

B. PRODUCT INSIDE (SEE FIGURE 2)

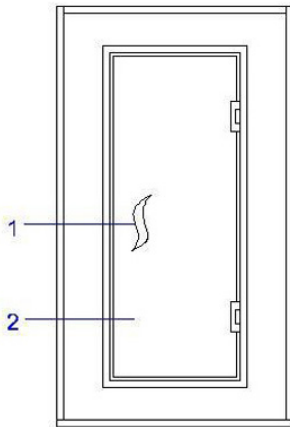

Figure 1

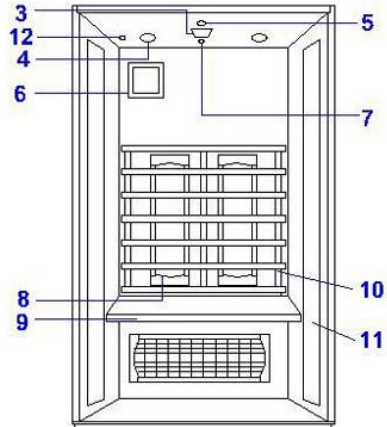

Figure 2

- 1) Handle
- 2) Safety glass door
- 3) Ventilation grid
- 4) Speaker
- 5) Reading lamp (11~15W)
- 6) Control panel
- 7) Temperature sensor
- 8) Heater
- 9) Bench panel
- 10) Back frame
- 11) Window
- 12) MP3 socket

1) TOOLS REQUIRED

Screwdriver, ladder

2) INSTALLATION ORDER

BOTTOM PANEL----- FRONT PANEL ----- RIGHT PANEL ----- LEFT PANEL -----
BACK PANEL -----BENCH---TOP PANEL---TOP COVER

For easy installation, please distinguish each panel feature:



Figure 10



Buckle inside panel ,for left/right
and front panel

Figure 12

To distinguish the back of the side panels, the front side has no clamps, while back side has clamps. Buckle inside panel (see figure 12).

Installation Instructions:

1) Choose a good location to install the sauna room

- A. MAIN POWER cord must be easily accessible.
- B. The location must be dry and leveled.
- C. Far from any source of water

Caution: Assembly of sauna requires at least 2 adults to complete.

2) Place the BOTTOM PANEL

Place the bottom panel on the floor, put "long size" side on the backside(see figure 13)

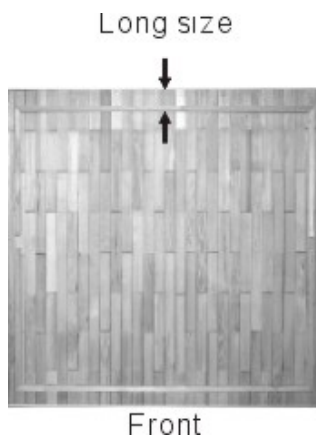

Figure 13

3) Install the front panel

Place the FRONT PANEL onto the recessed area on the BOTTOM PANEL. (see figure 14)



Figure 14

4) Install the LEFT/RIGHT PANEL

Remove the gum paper on the clamps, put the RIGHT PANEL on the BOTTOM PANEL in correct direction and click on tightly. When the RIGHT PANEL stands well on the BOTTOM PANEL, then install the LEFT PANEL in the same way. (SEE FIGURE 15~16)



Figure 15



Figure 16

5) Put on the BACK PANEL

Remove the gum paper on the clamps, place the BOTTOM PANEL in the correct direction and click on tightly. Align clips with LEFT/RIGHT PANEL and secure in place by fastening them. (see figure 17~18)



Figure 17



Figure 18

6) BUCKLE CONNECTIONS

How to connect panels using the buckles (see figures 5 to 7)

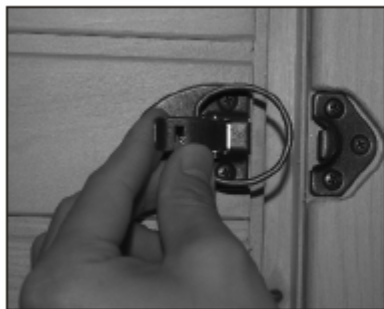

Figure 5



Figure 6



Figure 7

DO NOT USE THE BUCKLES TO FORCE THE PANELS TOGETHER

7) Install the bench panel

Install the bench panel by sliding it over the horizontal bench guides on the side panels. Push the bench all the way in until it can touch the BACK PANEL and is securely in place. Make sure of the bench position so that the smooth and finished side of the bench are facing up and forward. (see figure 19)



Figure 19

8) Place the TOP PANEL

- 1> The side with the CONTROL BOX is the up side.
- 2> The edge nearest to the CONTROL BOX is the front of TOP PANEL. (see figure 20)
Be careful of the wires in the SIDE PANELS before you set the TOP PANEL down. Feed these wires through the holes in the TOP PANEL. Feed the control cable and CD connectors down from the TOP PANEL through the long-shaped hole to the inside of the sauna.
- 3> Be careful not to force the TOP PANEL in to place without making sure that the wires are properly fed through the holes. (see figure 21)
- 4> When all wires are set, lower the TOP PANEL into place. (see figure 22)



Figure 22

9) CONTROL BOX

The control box is the control center of the sauna room and is installed on the TOP PANEL, input/output connection as below. (See Figure 3)



Figure 3

MAIN POWER
HT1, HT2,
READING LAMP
CTRL PANEL
CD/SIG

main power of the sauna room
heaters power output cable
reading lamp power output cable
control panel connecting
signal cable group

10) COMPONENT MARKINGS

For easy and proper installation, please read the information below thoroughly to make sure all connections are correct. (see form 1)

MARKING	COMPONENT CONNECTION
POWER	Power cord
FUSE	Fuse (15A) (reset)
HT1, HT2	Heater power cord
LIGHT	Reading lamp connector
CTRL	Control panel connecting
L/SPEAKER	Left speaker plug
R/SPEAKER	Right speaker plug
BUZZER	Buzzer plug
TEMP SENSOR	Temperature sensor

Form 1

Please read the operating instructions carefully before assembly. 2 adults are required for the sauna installation.

The power cord is taken out of the TOP COVER, do not plug in power during installation.

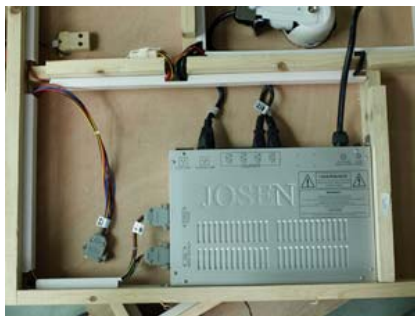

Figure20



Figure 21

11) Connect all the plugs on the TOP PANEL

1>. Plug in according to the respective label. (see figure 23-25)

2>. Connect the CTRL plug from the CONTROL BOX and CTRL plug from the CONTROL PANEL, then screw

it on . (see figure 26)

3> Plug the buzzer. (see figure 27)

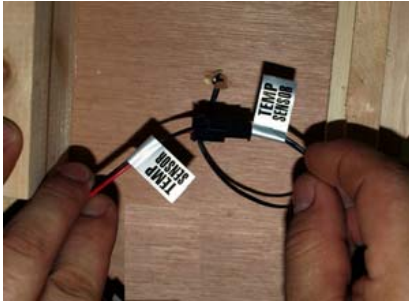

Figure 23



Figure 24

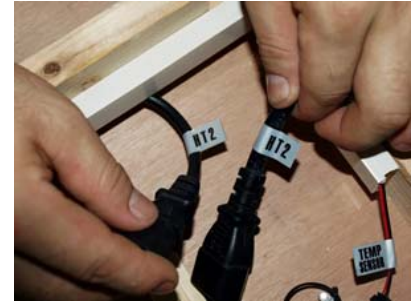

Figure 25

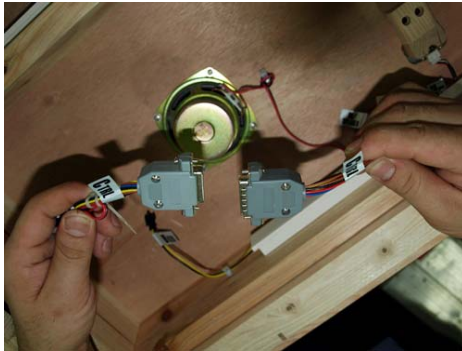

Figure 26

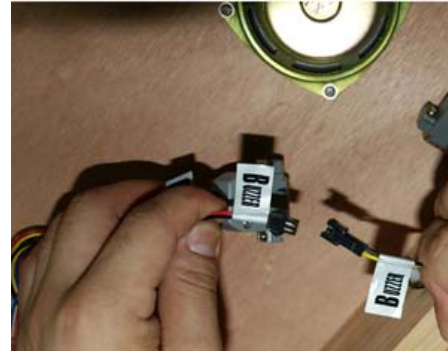

Figure 27

12) Temperature sensor

After connecting all the plugs, remove the adhesive film from the TEMPERATURE SENSOR.

13) Put on the TOP COVER

Lift the TOP COVER to the top of sauna room; take out the power cord from the round hole on the TOP COVER, gently place the TOP COVER onto the rest of the TOP PANEL. When the four edges are in the proper position, gently lower down and screw them securely in place. (see figure 29)



Figure 29

14) OPTIONAL MP3 Shelf

If your sauna comes with the optional MP3 shelf, use the two screws provided to mount the shelf on the front panel. (see figure 29A)



Figure 29A

15) Preparation

Plug the unit into a grounded (3-prong) outlet (120V 60Hz). The sauna is ready to be used. Read and follow all OPERATING INSTRUCTION.

SAUNA OPERATION

NOTE: Before powering on the sauna for the first time, please check and confirm the connection of all wiring (CONTROL BOX, HEATERS, TEMPERATURE SENSOR etc.) are correct and undamaged.

CONTROL PANEL FUNCTION

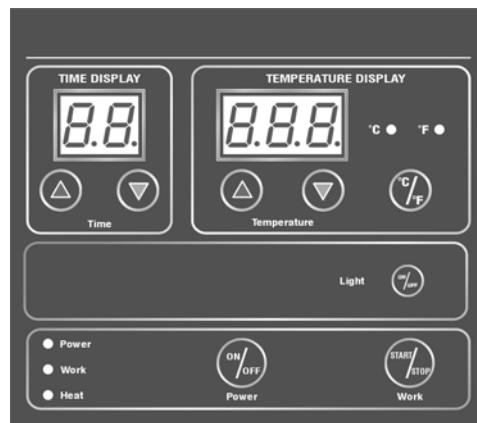

Figure 30

Power On /Off: Press to control the main power of the sauna unit.

Power indicator: Indicates the status of the sauna's main power.

Work Start/Stop: Press to control the working functions of the sauna.

Work indicator: Indicate the working status of the sauna.

Heat indicator: Indicate the status of heating functions.

Light: Press to control the lighting function

Time Display: Display the heating time of the sauna in minute(s)

Time: Press to adjust the setting of the timer.

Temperature Display: Display the actual interior temperature of the sauna room in $^{\circ}\text{C}/^{\circ}\text{F}$.

Temperature: Press to adjust the temperature setting

$^{\circ}\text{C}/^{\circ}\text{F}$: Press to change the temperature display between $^{\circ}\text{C}$ or $^{\circ}\text{F}$.

1. MAIN POWER: Plug in the main power to your household power.

2. SAUNA POWER: To power on the sauna, press POWER ON/OFF one time on the inside control panel, POWER light should then light up, The TIME DISPLAY will flash 60. TEMPERATURE DISPLAY will flash 60. If you press POWER ON/OFF again, power is off, while everything goes out.

3. HEATING TIME: When power is on, press TIME "▲" or "▼" to increase or decrease the emitting time of sauna room. When you press one time, it increases or decreases 1 minute. If you press the

set-up button continuously for more than 2 seconds, the digital will change quickly. If you don't press the button in more than 5 seconds, the digital will stop flashing, set-up value will be memorized. This value will be shown when you restart next time.

During sauna session, set-up time will count down the minutes one by one. When the left time is 5 minutes, the equipment will make a warning sound for 15 seconds, at this moment, time display is flashing. During these 15 seconds, you can press any set-up button to stop warning sound, and reset up the time of new sauna session. If you don't set up the time again, after 15seconds, sauna continues, when display time is 0, the equipment will power off automatically. Particularly the equipment will also power off if you don't press any bottom in 5 minutes after you power on the sauna!

4. Switch between °F and °C

When power is on, "°C" and "°F" will switch when you press "°C/°F". And the TEMPERATURE DISPLAY value will change accordingly.

5. Set up the heating temperature

When you turn the power on, press TEMPERATURE button "▲" or "▼" to increase or decrease the heating temperature of sauna room. The temperature will increase or decrease 1 minute when you press one time. If you press the set-up button continuously for more than 2 seconds, the digital will change quickly. This value will be the set-up sauna temperature. If you don't press the button in more than 5 seconds, the digital will stop flashing, set-up value will be memorized. It will show this value when you restart the next time.

6. Start emitting or stop emitting

When powering the sauna on, press WORK START/STOP button one time, WORK and HEAT light is on, the emitters will start emitting. (If you press this button again, emitters are off, WORK and HEAT light is off.) In the summer (room temperature is around 30°C/86°F), (such as 2 person sauna) heating time and actual inside temperature like the following datasheet:

actual inside temperature	40°C(104°F)	50°C(122°F)	55°C(131°F)	60°C(140°F)	66°C(150.8°F)
Heating time (minutes)	5~7	17~19	23~25	31~33	43~45

When environmental temperature is low, heating requires additional time. The above data is only for your reference. When the temperature is at the set-up value, the digital control will maintain the set temperature. The WORK light will remain on and the HEAT light will turn off. When the top heating, the sauna will maintain the set-up temperature for some time, when the inside temperature drops 2°C, the digital control will make the emitters continue heating until it reaches the set-up value. With the digital control, the inside sauna temperature is always around the set-up value.

7. Inside reading lamp switch

1) Press the light ON/OFF button one time to switch on, press again to switch off.

8. MP3 socket: Connect your MP3 player or radio (not supplied) to the MP3 socket while taking a sauna, the speakers will then work. (see figure 31)



Figure 31

Tips for Using Your Sauna

- 1) If you take a hot /warm shower or bath before your sauna session, you may perspire more and feel more comfortable.
- 2) Drink some water prior to, during, and after your sauna session to replenish body moisture.
- 3) Regulate the set temperature inside the sauna until you feel comfortable, or use the movable roof ventilation, or leave the door open (by setting it at an angle).
- 4) Use at least 2-3 towels .Sit on one towel folded over several times for added cushion. Put another towel on the floor to absorb extra sweat, a third towel draped over the knees to towel off sweat often for even sweating.
- 5) At the first sign of cold or flu increasing your sauna sessions may be beneficial in boosting your immune system and decreasing the reproductive rate of the viruses.
- 6) To help relieve sore and tense muscles, massage the affected areas while in sauna to help heal faster.
- 7) To treat your ankles and feet more effectively, you can elevate them and move as close to one emitter to achieve a specific deep heating effect as you feel comfortable.
- 8) To utilize the sauna's heat therapy effect, put oil or treatment into your hair and wrap it with towel. After the session is over, rinse your hair thoroughly.
- 9) You can benefit from the relaxing and soothing effects of a regular sauna session by going to sleep afterwards. The peaceful and relaxed state rendered by a sauna session will help you sleep easier and better.
- 10) After the session is over, do not jump into the shower immediately. Since your body was heated up during the session, it will continue to sweat even after the emitters are off. Sit in the sauna with the door open and let the body sweat a little more while it cools off. Once you feel comfortable enough, take a warm (or cool) shower to rinse the perspiration off your body.

Safety Instructions

- 1) Read and follow all instructions carefully before you use sauna.
 1. When installing and using this electrical equipment, basic safety precautions should always be followed.
 2. To reduce the risk of injury, do not allow children to use the sauna unless they are closely supervised at all times.
 3. Do not use the sauna immediately following strenuous exercise. Wait at least 30 minutes to allow the body to cool down completely.
 4. Pregnant or possibly pregnant women should contact their physician prior to using the sauna. Excessive

temperature has a high potential for causing fetal damage during the early months of pregnancy.

5. Hyperthermia Danger: the normal body temperature can't rise above 39 °C (103°F). Symptoms of excessive hyperthermia include dizziness, lethargy, drowsiness, and fainting. The effects of excessive hyperthermia may include failure to perceive heat, physical inability to exit sauna, unawareness of impending hazard, unconsciousness and fetal damage in pregnant women. Hyperthermia will make your body's core temperature rise, the high sauna temperature set-up is not recommended.
6. The use of alcohol, drugs, or medications prior to or during the sauna session may lead to unconsciousness.
7. Persons suffering from obesity or with a medical history of heart of heart disease, low or high blood pressure, circulatory system problems, or diabetes should consult a physician prior to using the sauna.
8. Persons using medications should consult a physician before using the sauna since some medications may induce drowsiness while others may affect heart rate, blood pressure, and blood circulation.
9. Exercise care before or after the sauna.
10. Never sleep inside the sauna while the sauna unit is working.
11. Do not use any type of cleaning agents on the interior of the sauna.
12. Do not stack or store any object on top of or inside the sauna.
13. If power supply cord becomes damaged, it must be replaced immediately by the manufacturer or its agent or a similarly qualified person. If you find the power cord is too hot, the electrical equipment may be in trouble, please ask the manufacturer or its agent's to inspect the unit to avoid a hazard.
14. Do not use the sauna during an electrical storm to avoid risk of shock.
15. Do not switch on or off the power and heating system, it will destroy the electrical equipment easily.
16. Dry your hands before you plug in or pull out the power and control circuit. Never operate with wet hands or with wet bare feet to avoid risk of electric shock. Don't have your finger touch the metal pins of plug.
17. Do not attempt any repair by yourself, if you have a problem, please consult the selling distributor or the manufacturer to eliminate safety risks. Unauthorized repair attempts will void manufacturer's warranty.
18. Please make sure the outlet power supply is big enough for your sauna. An under rated outlet will cause the cord to heat and pose a safety risk.
19. In some sauna models with roof lamps, the lamp temperature is very high once you power on and the light is on. Do not touch the lamp to prevent burns. Also, do not touch it for 20 minutes after it has stopped emitting.
20. Do not pour water or other liquids on the infrared emitters. Do not bump the elements with something hard which could break the element and cause an electrical short. Please be careful of this!

Safeguards for Your Sauna

1. Do not use your sauna near water, e.g. near a bathtub, in a wet basement, or near a swimming pool.
2. Do not take a shower near the sauna to keep the wood material dry enough in case of deformation under water. Do not pour the water or other liquids to emitters and electrical equipments.
3. Do not use liquid cleaners or aerosol cleansers inside the sauna. Unplug the sauna from the wall outlet before cleaning. Use damp cloth for cleaning.
4. Power supply cord should be routed so it is not likely to be walked on or pinched by items placed upon or against it. Please protect the power cord and do not step on it on the ground, as it is a hazard. If the outlet is not near your sauna, we recommend unplugging it and coiling the cord when not in use.
5. When replacement parts are required, be sure they are specified by the manufacturer or have the same characteristics as the original parts. Unauthorized substitutes may result in fire, electric shock or other hazards .After repair, please ask the service technician to perform safety checks to determine that your sauna is in proper operating condition, and then you can use it.

Troubleshooting Guide

1. Press LIGHT on the control panel, but reading lamp does not on.

Solution: 1) Unplug the MAIN POWER

- 2) Before you check the light, please feel if the light cover is hot, YOU can check it until it cools down.
- 3) Remove the TOP COVER of the sauna room.
- 4) Screw off the cooper nuts on lamp cover.
- 5) Remove the lamp holder.
- 6) Screw off the bulb gently.
- 7) Replace a new bulb with same voltage and wattage if the bulb is bad, and screw down gently.
- 8) Put on the TOP COVER and fasten the clamps.

2. When sauna is working, but some emitters are not heating up.

Solution: 1) Unplug the MAIN POWER.

- 2) Remove the top cover
- 3) Push the reset switch located next to the power cord on the back of the controlbox.
- 4) If the emitters are still not heating, call the distributors customer service department for further instructions.

Please ask the distributor's technician to repair when you meet with the following problems. DO not Repair the sauna unit by yourself.

3. Emitter becomes red when power on. This is emitter problem, do not continue heating, you should replace the emitter.
4. Emitter is broken or damaged. DO not continue to operate, and replace a new emitter.
5. CONTROL BOX has some abnormal phenomenon: such as, so high temperature; bad smell or make some sound; please power off immediately. Contact the distributor's technician for checking.
6. Power cord or other cables are damaged or disconnection. do not use it again. Replace a power cord and connector etc. components.

Control panel troubles and reasons:

7. Control panel: No display.

- Possible reasons:
- 1) The electricity power is not plugged well or lose contact, and it is not powered.
 - 2) The CTRL connector on the CONTROL BOX is not plugged or lose contact.
 - 3) CTRL cable is disconnected.
 - 4) CONTROL BOX is damaged.

8. Control panel with display, but no function when you press on it.

- Possible reasons:
- 1) Signal cable is disconnected.
 - 2) Relevant plugs are not connecting or lost contact.

9. Emitter is working, inside sauna temperature is rising, but the temperature display does not change.

- Possible reasons:
- 1) Temperature sensor is damaged.
 - 2) Temperature sensor down-lead is disconnected.
 - 3) Temperature sensor down-lead connector is not connected or lose contact.

Note: You should keep the serial number for product warranty, (which is shown on the sauna Front Panel and outside package), and please give this information to your distributor for timely and efficiently after sale service.

Warranty



Infrared Saunas Keys Backyard PRODUCTS, LP – LIMITED WARRANTY PLEASE CONSULT YOUR PHYSICIAN BEFORE USING THIS PRODUCT.

This Limited Warranty applies in the United States and Canada to products manufactured or distributed by Keys Backyard Products, LP ("Keys") under the KEYS brand name. The warranty period on the Keys Infrared Sauna is limited to the original purchaser. The warranty period is as follows:

One Year -Wood, Electronics, Heating Elements. 90 Days -Labor

Warranty period starts from date of receipt of Infrared Sauna.

Keys warrants that the Product you have purchased for non-commercial, personal, family, or household use from Keys or from an authorized Keys reseller is free from defects in materials or workmanship under normal use during the warranty period. Your sales receipt, showing the date of purchase of the Product, is your proof of the date of purchase. This warranty only extends to you, the original purchaser. It is not transferable to anyone who subsequently purchases the Product from you.

During the warranty period Keys will at no additional charge, repair or replace (at Keys' option) the product if it becomes defective, malfunctions, or otherwise fails to conform with this Limited Warranty under normal non-commercial, personal, family or household use. In repairing the Product, Keys may replace defective parts, or at the option of Keys, serviceable used parts that are equivalent to new parts in performance. All exchanged parts and Products replaced under this warranty will become the property of Keys. Keys reserves the right to change manufacturers of any part to cover any existing warranty.

To obtain warranty service, you must contact a Keys Backyard at our phone numbers located in this manual. Any parts determined to be defective must be returned to Keys to obtain warranty service. You must prepay any shipping charges, export taxes, custom duties and taxes, or any other charges associated with transportation of the parts or Product. In addition, you are responsible for insuring any parts or Product shipped or returned. You assume the risk of loss during shipment. You must present Keys with proof-of-purchase documents (including the date of purchase). Any evidence of alteration, erasing or forgery of proof-of-purchase documents will be cause to void this Limited Warranty.

This warranty does not extend to any product not purchased from Keys or from an authorized Keys reseller. This Limited Warranty does not extend to any Product that has been damaged or rendered defective; (a) as a result of accident, misuse, or abuse; (b) by the use of parts not manufactured or sold by Keys; (c) by modification of the Product or normal wear and tear; (d) operation on incorrect power supplies; or (e) as a result of service by anyone other than Keys, or an authorized Keys warranty service provider. Product on which the serial number has been defaced or removed is not eligible for warranty service. Should any Product be submitted for warranty service be found ineligible therefore, an estimate of repair cost will be furnished and the repair will be made if requested by you upon Keys' receipt of payment or acceptable

arrangements for payment.

This sauna is not intended for outdoor use. Placing your sauna outdoors will void this warranty. Any alterations to the product will void the warranty. Any damage to the sauna due to exposure to outdoor elements (Rain, Snow, Wind, Sun) is not covered under this warranty. EXCEPT AS EXPRESSLY SET FORTH IN THIS WARRANTY, KEYS MAKES NO OTHER WARRANTIES, EXPRESSED OR IMPLIED, INCLUDING ANY IMPLIED WARRANTIES OF MERCHANTABILITY AND FITNESS FOR A PARTICULAR PURPOSE. KEYS EXPRESSLY DISCLAIMS ALL WARRANTIES NOT STATED IN THIS LIMITED WARRANTY. ANY IMPLIED WARRANTIES THAT MAY BE IMPOSED BY LAW ARE LIMITED TO THE TERMS OF THIS LIMITED WARRANTY. NEITHER KEYS NOR ANY OF ITS AFFILIATES SHALL BE RESPONSIBLE FOR INCIDENTAL OR CONSEQUENTIAL DAMAGES. SOME STATES DO NOT ALLOW LIMITATIONS ON HOW LONG AN IMPLIED WARRANTY LASTS OR THE EXCLUSION OR LIMITATION OF INCIDENTAL OR CONSEQUENTIAL DAMAGES, SO THE ABOVE LIMITATIONS OR EXCLUSION MAY NOT APPLY TO YOU. This Limited Warranty gives you specific legal rights and you may also have other rights that may vary from state to state. This is the only express warranty applicable to Keys-branded products. Keys neither assumes nor authorizes anyone to assume for it any other express warranty.