



**HOSHIZAKI  
MODULAR CRESCENT CUBER**

**MODEL**

**KM-1601MRH**

**KM-1601MRH3**

**PARTS LIST**

## CONTENTS

Auxiliary Codes.....	3
Note About Ordering Parts .....	3
Material Abbreviations .....	4
A. Ice Cuber Assembly .....	5
KM-1601MRH, MRH3 .....	5
B. Refrigeration Circuit .....	7
KM-1601MRH, MRH3 .....	7
C. Water Circuit.....	11
KM-1601MRH, MRH3 .....	11
D. Control Box Assembly .....	14
KM-1601MRH, MRH3 .....	14
E. Label Location .....	16
KM-1601MRH, MRH3 .....	16
F. Capacitor Box Assembly .....	18
KM-1601MRH .....	18
F. Transformer Box Assembly.....	19
KM-1601MRH3 .....	19
G. Evaporator .....	20
KM-1601MRH, MRH3 .....	20
H. Pump Motor Assembly .....	21
KM-1601MRH, MRH3 .....	21
J. Accessories.....	22
KM-1601MRH, MRH3 .....	22

## **Auxiliary Codes**

**KM-1601MRH**      Q-0    May 2005

**KM-1601MRH3**    Q-0    May 2005

## **Note About Ordering Parts**

Most assemblies cannot be ordered as complete units; parts in the assemblies generally must be ordered separately.

## Material Abbreviations

### ALUMINUM

AL = Aluminum

### COPPER

CU = Copper

### PLASTIC

ABS = Acrylonitrile -butadiene - styrene  
AC = Polyacetal  
EVA = Ethylene vinyl acetate  
PA = Polyamide = Nylon  
PC = Polycarbonate  
PE = Polyethylene  
PES = Polyester  
PETP = Polyethylene terephthalate = Tetlon  
PP = Polypropylene  
PS = Polystyrene  
PTFE = Polytetrafluoroethylene = Teflon  
PUR = Polyurethane  
PVC = Polyvinyl chloride

### RUBBER

VN = Vinyl Nitrile  
EPDM = EP rubber  
NBR = Nitrile butadiene rubber  
NR = Natural rubber  
NP = Neoprene  
SI.R = Silicone rubber  
SY.R = Synthetic rubber  
EPH = Epichlorohydrin

### STEEL

GS = Galvanized steel  
SS = Stainless steel  
PS = Plated steel  
PAS = Primed steel

### AUXILIARY CODE

K-0

┌─ Designates the year. "K" indicates the year 2000. Years progress or regress in alphabetical order.  
├─ "J" is 1999, "L" is 2001, "M" is 2002, and so on. The letters "I" and "O" were skipped.  
└─ Designates significant part changes within the same year for this model. Base is 0 and this number advances for each change.

Example: P-1

┌─ "P" indicates 2004.  
└─ "1" indicates the first significant part change for 2004.

**A. Ice Cuber Assembly**  
**KM-1601MRH, MRH3**  
 Q-0

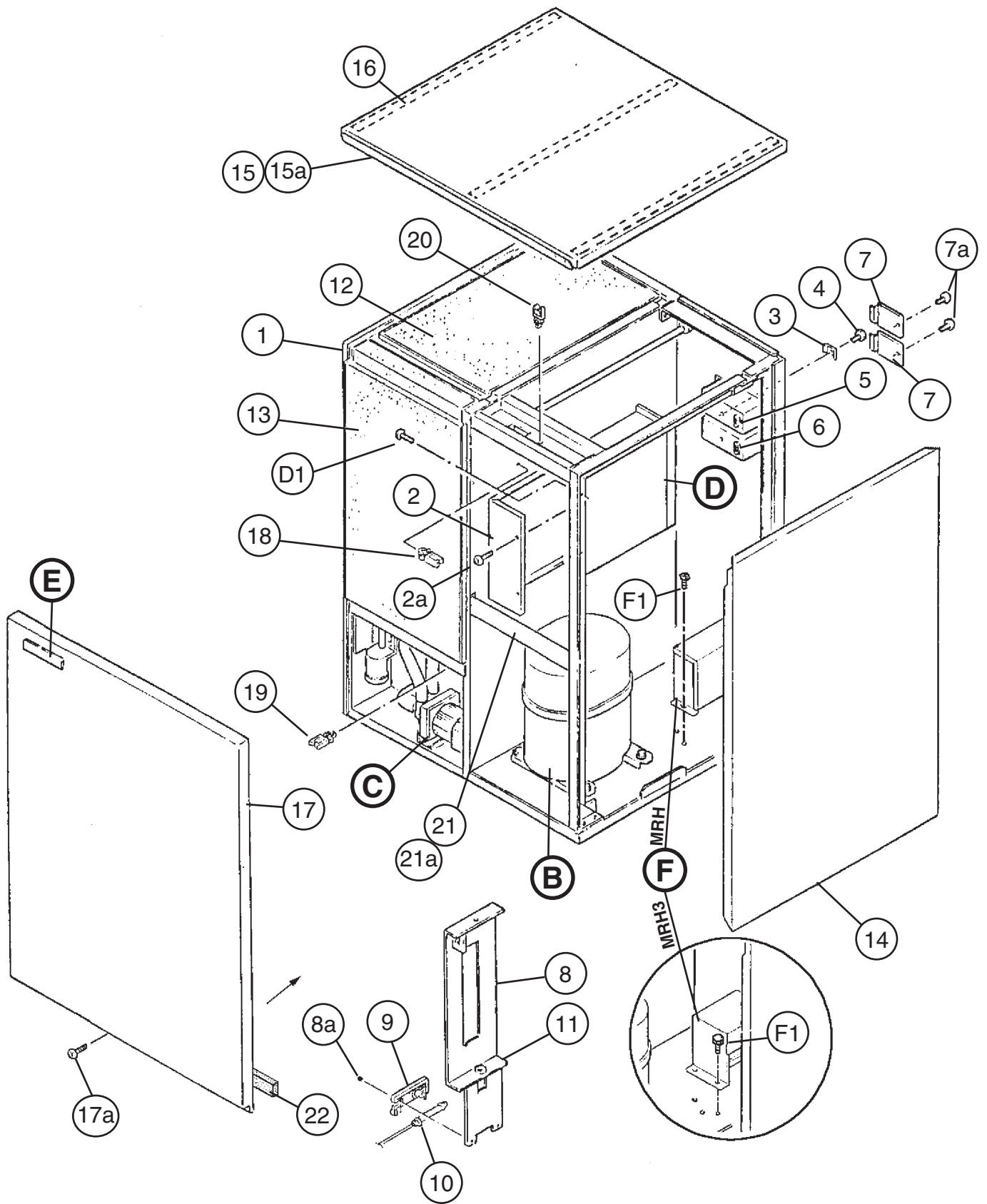

Title: **A. Ice Cuber Assembly** Model: **KM-1601MRH, MRH3**

Index No.	Description	Material or Model Number	Part Number	Required Number																
				Q-0																
B	Refrigeration Circuit	<b>KM-1601MRH</b>	1A0242A07	1																
		<b>KM-1601MRH3</b>	1A0242A08	1																
C	Water Circuit	-	1A0094A06	1																
D	Cont. Box Assembly	-	2A2527A01	1																
D1	T2 Screw	4x8	7P31-0408	3																
E	Label Location	<b>KM-1601MRH</b>	2A2528A03	1																
		<b>KM-1601MRH3</b>	2A2528A04	1																
F	Capacitor Box Assembly	<b>KM-1601MRH</b>	3A2054A02	1																
	Transformer Box Assembly	<b>KM-1601MRH3</b>	3A1102A01	1																
F1	T2 Screw	<b>KM-1601MRH</b> 4x8	7P31-0408	2																
	Hex Head Bolt w/Washer (LF)	<b>KM-1601MRH3</b> 5x10	7B0130510	4																
1	Evaporator Case	-	1A0602G01	1																
2	Cont. Box Cover	GS	3A2386-01	1																
2a	T2 Screw	4x8	7P31-0408	2																
3	Square Washer	COPPER	433537-02	2																
4	Screw – Grounding	BRASS	433304-02	2																
5	Bushing	SR-30-1	420472-03	1																
6	Bushing	SR-34-2	420472-05	1																
7	Junction Box Cover	GS	433410-01	2																
7a	T2 Screw	4x8	7P31-0408	2																
8	Bulb Holder	-	322815G02	1																
8a	FT Screw	4x10, SS	7F32-0410	2																
9	Bulb Holder	ABS	328919-01	1																
10	Spacer	PE	443545-01	2																
11	Bushing	EPDM	425307-01	1																
12	Top Insulation	ABS, PE	322714G01	1																
13	Front Insulation	ABS, PE	322711G01	1																
14	Side Panel (R)	SS	2A2165G01	1																
15	Top Panel	(3A1941A01)	2A2163-01	1																
15a	Truss Head Screw	4x8, SS	7C32-0408	1																
16	Gasket	(3A1941A01)	427014-04	3																
17	Front Panel (A)	SS	2A2164-02	1																
17a	Truss Head Screw	4x8, SS	7C32-0408	1																
18	Wire Saddle	-	4A0338-03	5																
19	Wire Saddle	-	4A0338-02	2																
20	Wire Saddle	-	4A0338-01	1																
21	Frame (F)	-	324093-01	1																
21a	T2 Screw	4x8	7P31-0408	4																
22	Gasket	L=762	4A0808L02	1																

**B. Refrigeration Circuit**  
**1/2**  
**KM-1601MRH, MRH3**  
**Q-0**

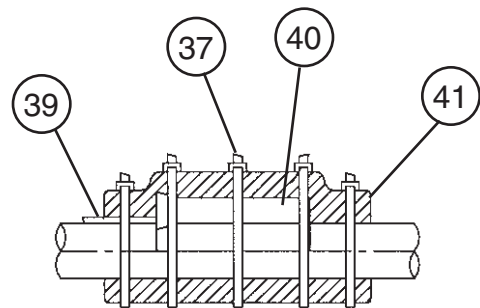
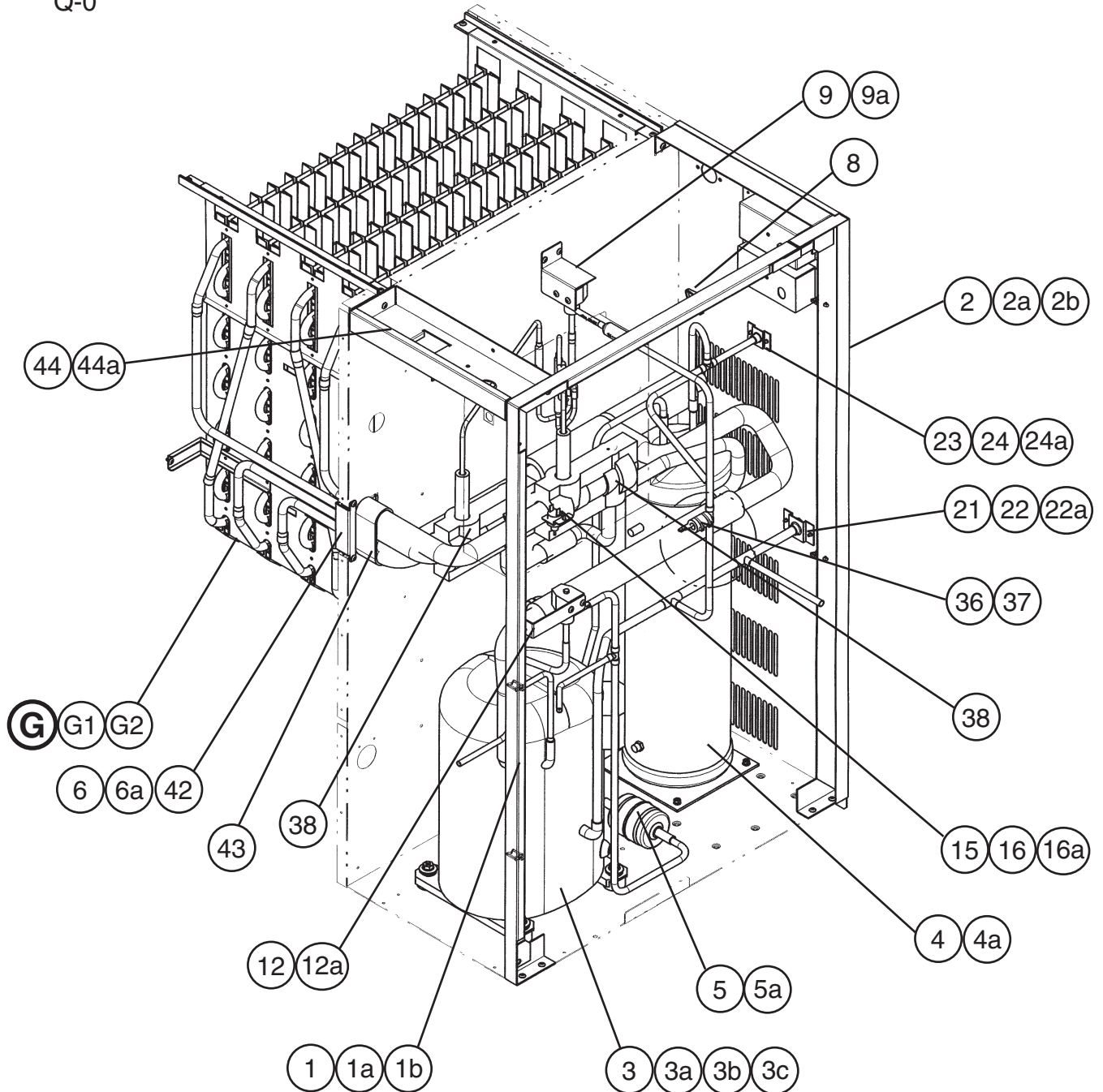

Thermistor Attachment Detail

# B. Refrigeration Circuit

2/2

KM-1601MRH, MRH3

Q-0

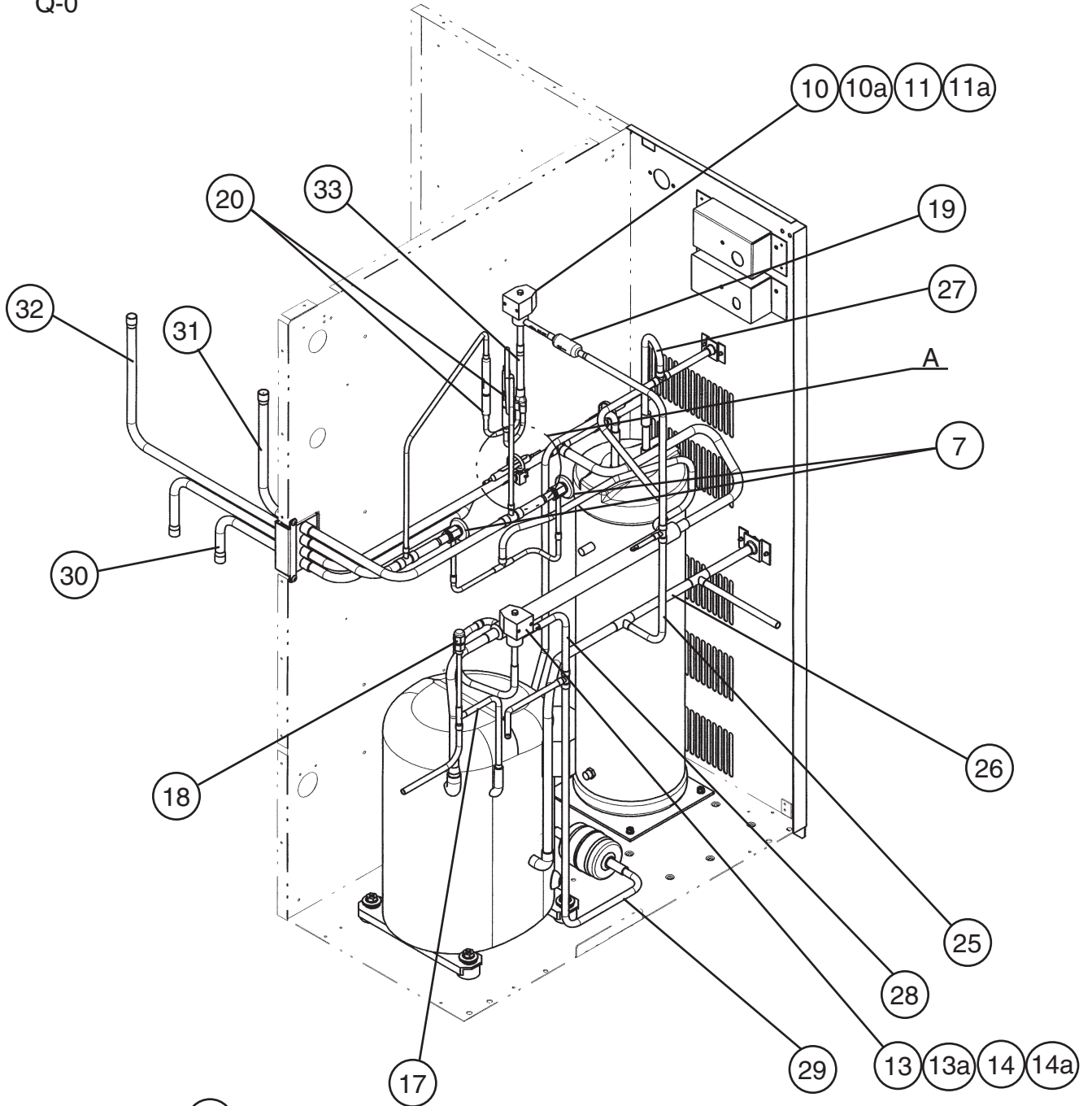

Detail "A"



Title: <b>B. Refrigeration Circuit</b> Model: <b>KM-1601MRH, MRH3</b>													
Index No.	Description	Material or Model Number	Part Number	Required Number									
				Q-0									
G	Evaporator	-	104442G03	1									
G1	Truss Head Screw	4x8, SS	7C31-0408	4									
G2	T2 Screw	4x8, SS	7P32-0408	4									
1	Frame	GS	222024G02	1									
1a	FT Screw	4x8, SS	7F32-0408	4									
1b	T2 Screw	4x8	7P31-0408	4									
2	Rear Panel	GS	222025G04	1									
2a	FT Screw	4x8, SS	7F32-0408	5									
2b	T2 Screw	4x8	7P31-0408	5									
3	Compressor	<b>KM-1601MRH</b> CS18K6E-PFV-279	4A2334-02	1									
		<b>KM-1601MRH3</b> CS18K6E-TF5-279	4A2330-02	1									
3a	Grommet	-	434922-01	4									
3b	Spacer	-	434921-01	4									
3c	Bolt	8x45	437889-01	4									
4	Receiver Tank	RR MN WP500	440366-01	1									
4a	Hex Head Bolt w/Washer (LF)	5x10	7B0130510	3									
5	Drier	C-05E84	4A2663-01	1									
5a	Nylon Tie	PLWP3H-TL	8911-0301	1									
6	Insulation Holder	-	3A0979-01	1									
6a	T2 Screw	4x8, SS	7P32-0408	2									
7	Expansion Valve	HFE-15NHD-2	4A1482-01	2									
8	Clamp	-	4A2338-01	1									
9	Hot Gas Valve Bracket	GS	444816-01	1									
9a	T2 Screw	4x8	7P31-0408	2									
10	Valve Body	70	440352-01	1									
10a	Bolt	4x6	440353F01	1									
11	Coil – Valve	ABS-25-1- HD-2	440353-01	1									
11a	Truss Head Screw	4x8	7C31-0408	2									
12	Line Valve Bracket	GS	4A1544-01	1									
12a	T2 Screw	4x8	7P31-0408	2									
13	Valve Body	70	440352-01	1									
13a	Bolt	4x6	440353F01	1									
14	Coil – Valve	ABS-25-1- HD-2	440353-01	1									
14a	Truss Head Screw	4x8	7C31-0408	2									
15	Pressure Switch	ACB-1UB09	433441-07	1									
16	Press. Switch Bracket	GS	434938-01	1									
16a	T2 Screw	4x8	7P32-0408	1									
17	Copper Tube – Access Valve	COPPER	4A1497G01	1									

Title: <b>B. Refrigeration Circuit</b> Model: <b>KM-1601MRH, MRH3</b>												
Index No.	Description	Material or Model Number	Part Number	Required Number								
				Q-0								
18	Access Valve	TCJ-2F20NHDU-1	457729-01	1								
19	Strainer	-	441569-02	1								
20	Check Valve	SKC30564	4A1373-01	2								
21	Coupling	-	434136G01	1								
22	Tube Holder – L	GS	438245-01	1								
22a	T2 Screw	4x8	7P31-0408	2								
23	Coupling	-	433751G01	1								
24	Tube Holder – S	GS	438246-01	1								
24a	T2 Screw	4x8	7P31-0408	2								
25	Copper Tube (A) – High Side	COPPER	2A3136G01	1								
26	Copper Tube (B) – High Side	COPPER	447737G01	1								
27	Copper Tube (D) – High Side	COPPER	3A1603G01	1								
28	Copper Tube (E) – High Side	COPPER	3A3466-01	1								
29	Copper Tube (F) – High Side	COPPER	2A3457G01	1								
30	Heat Exchanger	COPPER	1A1047G01	1								
31	Copper Tube (R) – Low Side	COPPER	222029G02	1								
32	Copper Tube (L) – Low Side	COPPER	222030G02	1								
33	Copper Tube – Hot Gas	COPPER	3A3491G01	1								
34	Holder / Expansion Valve – 3/8	SS	3A0107-01	2								
35	Clamp	SS	443461-01	2								
36	Insulation Tube	L=40	7762-1020	1								
37	Cable Tie	-	7920-0010	12								
38	Expansion Valve Cover	PE FOAM	3A0944-01	2								
39	Thermistor	-	429006-03	1								
40	Holder – Thermistor	COPPER	438247-01	1								
41	Insulation – Thermistor	PE FOAM	427441-01	1								
42	Insulated Rubber Tube	EPDM	323975G01	1								
43	Insulation	PE FOAM	436671-01	1								
44	Frame (C)	-	3A0347-01	1								
44a	T2 Screw	4x8	7P31-0408	2								

**C. Water Circuit**  
**KM-1601MRH, MRH3**  
 Q-0

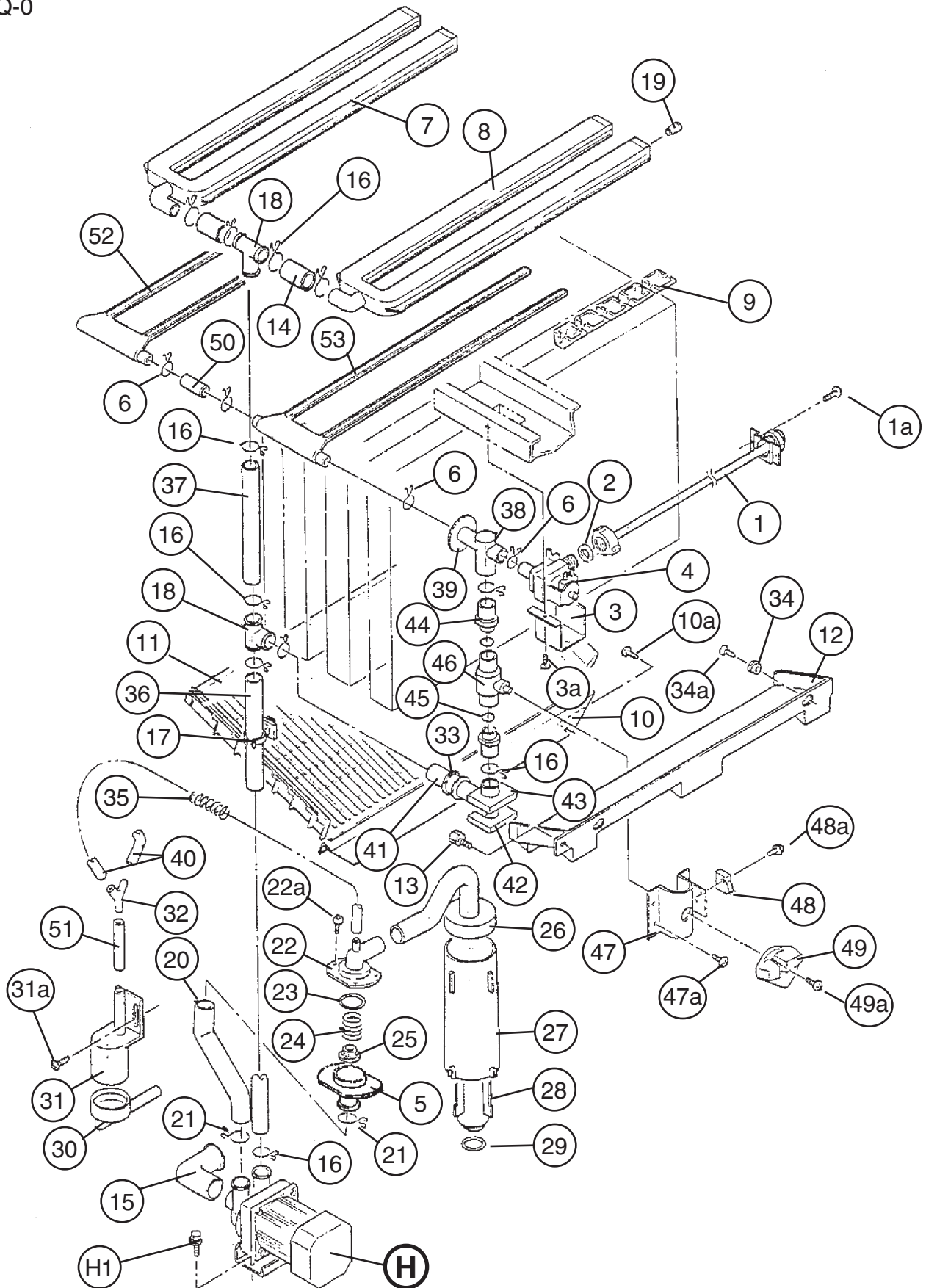

Title: **C. Water Circuit** Model: **KM-1601MRH, MRH3**

Index No.	Description	Material or Model Number	Part Number	Required Number																
				Q-0																
H	Pump Motor Assembly	(S-0731)	215693A01	1																
H1	Hex Head Bolt w/Washer (LF)	SS, 5x12	7B0230512	1																
1	Water Supply Pipe	COPPER	4A0768G01	1																
1a	T2 Screw	4x8	7P31-0408	2																
2	Rubber Gasket	NR	413854-03	1																
3	Water Valve Bracket	GS	321443-01	1																
3a	T2 Screw	4x8	7P31-0408	1																
4	Water Valve	J248-032	3U0111-02	1																
5	Valve Housing – Drain	-	435054-01	1																
6	Hose Clamp	SS, 18MM	427443-05	4																
7	Spray Tube	PE	1A0260-02	1																
8	Spray Tube	PE	1A0260-01	1																
9	Spray Guide (A)	PE	208586-01	12																
10	Plate	SS	3A0133-01	1																
10a	T2 Screw	SS, 4x10	7P32-0410	4																
11	Cube Guide (A)	SS	214905-01	1																
12	Cube Guide (B)	ABS	322644-02	1																
13	Thumbscrew	ABS, SS	415949G12	1																
14	Vinyl Hose	L=63	7716-2025	2																
15	Hose (A)	EPDM	435091-01	1																
16	Hose Clamp	SS, 25MM	427443-03	11																
17	Holder	PP	322692-01	1																
18	Distributor	ABS	432426-01	2																
19	Plug	Santoprene	4A0176-01	4																
20	Drain Hose	EPDM	435092-01	1																
21	Hose Clamp	SS, 27MM	427443-08	2																
22	Drain Valve (B)	ABS	3A1170-01	1																
22a	T2 Screw	SS, 4x16	7P32-0416	3																
23	“O” Ring	1AG35	7611-G035	1																
24	Spring	SS	322685-01	1																
25	Valve Seat	EPDM	433705-01	1																
26	Hose (C)	EPDM	326655-01	1																
27	Overflow Cap	ABS	322816-01	1																
28	Overflow Pipe	ABS	322691-01	1																
29	“O” Ring	-	4A1234-01	1																
30	Connector – Float Switch	EPDM	426799-01	1																
31	Float Switch	163790	4A0886-02	1																
31a	Truss Head Screw	SS, 4x8	7C32-0408	2																
32	Connector	ABS	432763-01	1																
33	Rubber Ring	TSE2571-5U	439236-01	1																
34	Collar	ABS	435269-01	2																
34a	T2 Flat Head Screw	SS, 4x16	7P22-0416	2																
35	Spring	SS	435825-01	1																
36	Vinyl Hose	L=670	7716-2025	1																

Title: **C. Water Circuit** Model: **KM-1601MRH, MRH3**

Index No.	Description	Material or Model Number	Part Number	Required Number									
				Q-0									
37	Vinyl Hose	L=190	7716-2025	1									
38	Tee	EPDM	4A0177-01	1									
39	Flange	EPDM	439267-01	1									
40	Silicone Hose	L=80	7730I3812	2									
41	Bypass Hose	EPDM	439265-01	1									
42	Corner Insulation (A)	PE FOAM	439376-01	1									
43	Corner Insulation (B)	PE FOAM	439392-01	1									
44	Male Adaptor	(442137A01)	325826-01	2									
45	"O" Ring		7611-P018	2									
46	Ball Valve		439293-01	1									
47	Valve Holder	GS	3A1178-01	1									
47a	FT Screw	4x8	7F31-0408	3									
48	Micro Switch	V3L-III-D8	4A0365-01	1									
48a	Tapping Screw	3x14	431415-02	2									
49	Handle	JH1352	215383-01	1									
49a	T2 Screw	4x8	7P31-0408	1									
50	Vinyl Hose	L=58	7716-1519	1									
51	Vinyl Hose	L=180	7716-0913	1									
52	Water Supply Tube	PE	2A0079-01	1									
53	Water Supply Tube	PE	2A0079-02	1									

**D. Control Box Assembly**  
**KM-1601MRH, MRH3**  
 Q-0

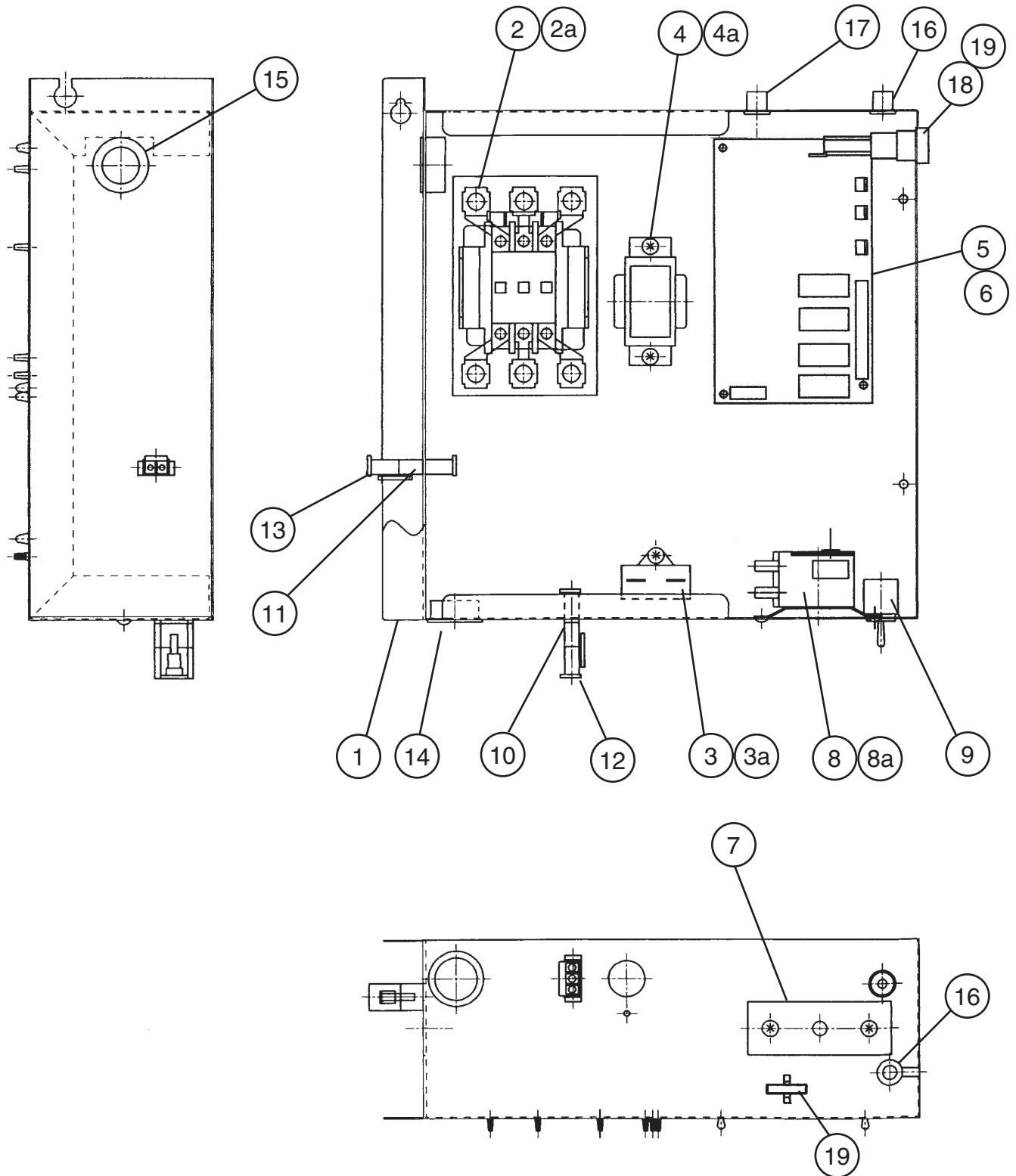

Title: **D. Control Box Assembly** Model: **KM-1601MRH, MRH3**

Index No.	Description	Material or Model Number	Part Number	Required Number									
				Q-0									
1	Cont. Box	GS	2A2524G01	1									
2	Magnetic Contactor	A77-309040A-226	4A0794-01	1									
2a	Truss Head Screw	4x12	7C31-0412	2									
3	Capacitor	250V, 10MFD	443192-01	1									
3a	T2 Screw	4x10	7P31-0410	1									
4	Transformer	26D285H	3A0172-01	1									
4a	T2 Screw	4x8	7P31-0408	2									
5	Controller Board	HOSHIZAKI-001	2A1410-01	1									
6	Board Support	CBLS37-M	4A0336-03	4									
7	Control Label	PES FILM	4A1758-01	1									
8	Thermostat	YTB-106B	4A2879-02	1									
8a	Truss Head Screw	4x6	7C31-0406	2									
9	Toggle Switch	8966K84	443119-01	1									
10	3p Plug Housing	3191-03P	412832-06	1									
11	2p Plug Housing	3191-02P	412832-07	1									
12	3p Receptacle Housing	3191-03R1	412831-06	1									
13	2p Receptacle Housing	3191-02R1	412831-07	1									
14	Bushing	SB-1093-15	420470-03	1									
15	Bushing	SB-1093-13	420470-12	1									
16	Bushing	OCB-500	428394-02	2									
17	Bushing	OCB-875	428394-04	1									
18	Fuse Holder	HTB921	4A0892-01	1									
19	Fuse	AGC-10	4A0893-07	2									

**E. Label Location**  
**KM-1601MRH, MRH3**  
 Q-0

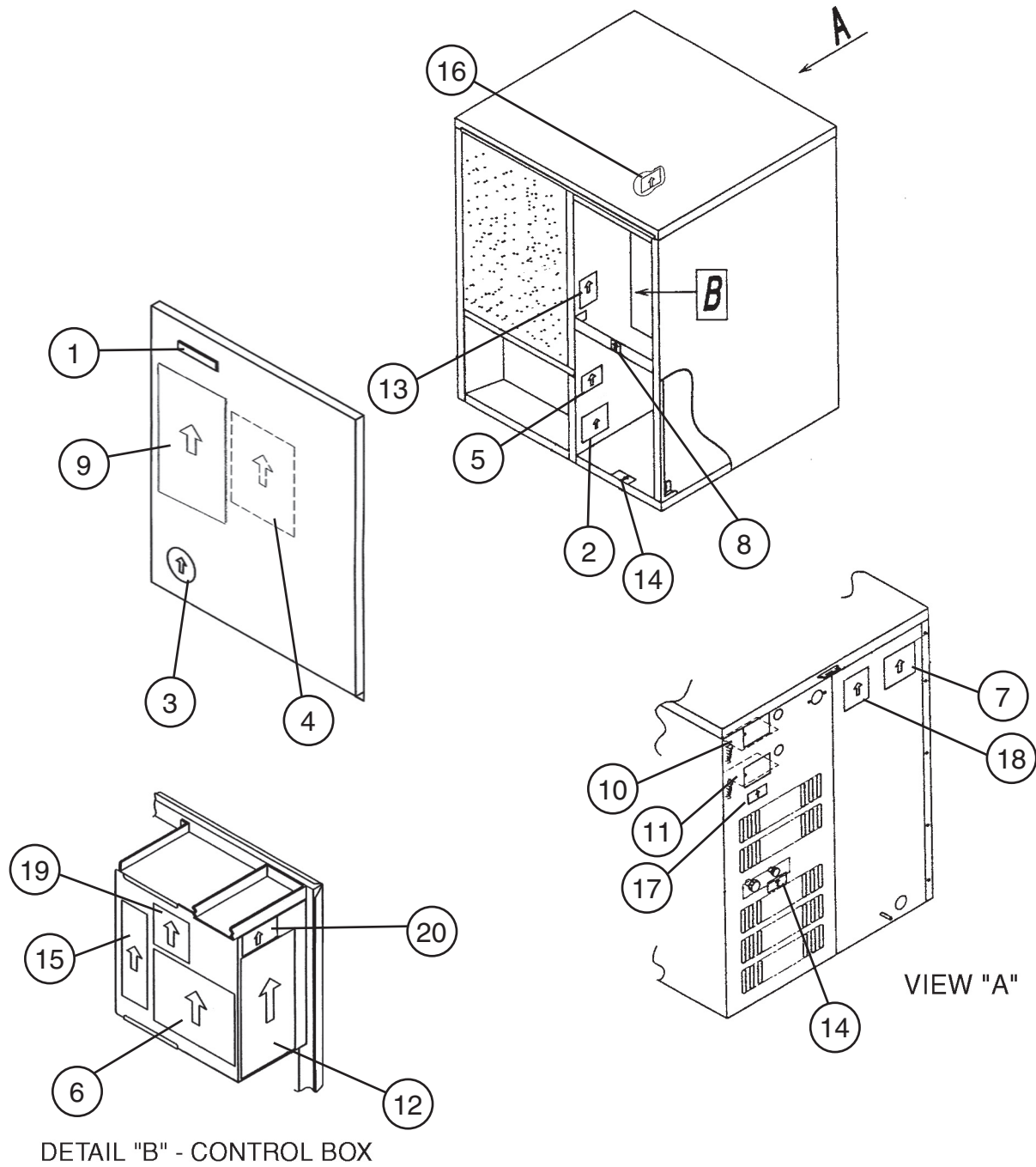



Title: **E. Label Location** Model: **KM-1601MRH, MRH3**

Index No.	Description	Material or Model Number	Part Number	Required Number									
				Q-0									
1	Emblem	ABS	4A0560-01	1									
2	Rating Label	<b>KM-1601MRH</b>	2A3460-01	1									
		<b>KM-1601MRH3</b>	2A3460-02	1									
3	Label – Penguin (R)	PETP FILM	4A0526-01	1									
4	Maintenance Label	PVC FILM	325975-01	1									
5	Caution Label (H)	PVC FILM	439148-01	1									
6	Wiring Label	<b>KM-1601MRH</b>	3A3492-01	1									
		<b>KM-1601MRH3</b> PVC FILM	3A2394-01	1									
7	Nameplate	<b>KM-1601MRH</b>	2A3459-01	1									
		<b>KM-1601MRH3</b> PES FILM	2A3459-02	1									
8	Caution Label	PVC FILM	436198-01	1									
9	Instruction Sheet	PAPER	2A3633-01	1									
10	Tag Warning: Electrical Connection	<b>KM-1601MRH</b>	428430-01	1									
		<b>KM-1601MRH3</b> PAPER	438479-01	1									
11	Tag – Fan Motor Leads	PAPER	4A1494-01	1									
12	Manual Label	PVC FILM	324476-01	1									
13	Manual Label – Bin Control	PVC FILM	322846-01	1									
14	Label – R404A	PES FILM	4A0960-01	2									
15	Label – Control Board		3A2220-01	1									
16	Operation Label – Valve	PVC FILM	439541-01	1									
17	Caution – Remote Label	PVC FILM	4A1491-01	1									
18	Instruction Label	PVC FILM	444575-01	1									
19	Label – Alarm		4A3517-01	1									
20	Label – Fuse		4A2817-01	1									

# F. Capacitor Box Assembly

**KM-1601MRH**

Q-0

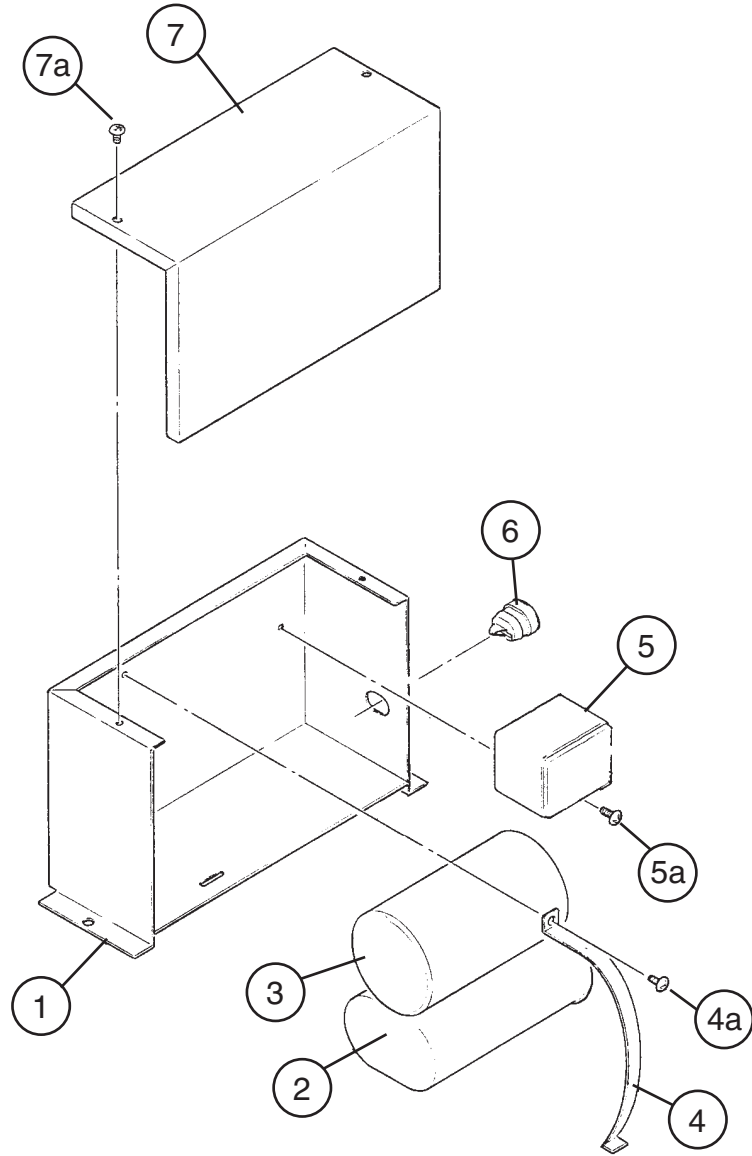

Title: F. Capacitor Box Assembly Model: KM-1601MRH					Required Number									
Index No.	Description	Material or Model Number	Part Number	Q-0										
1	Capacitor Box	GS	326124-02	1										
2	Capacitor – Run	35MFD 370V	3A2005-05	1										
3	Capacitor – Starting	145-175MFD250V	3A0076-01	1										
4	Strap	GS	4A2262-03	1										
4a	T2 Screw	4x8	7P31-0408	1										
5	Starter	-	4A1107-09	1										
5a	T2 Screw	4x8	7P31-0408	1										
6	Bushing	SR-34-1	420472-05	1										
7	Capacitor Box Cover	GS	326125-01	1										
7a	T2 Screw	4x8	7P31-0408	2										

# F. Transformer Box Assembly

## KM-1601MRH3

Q-0

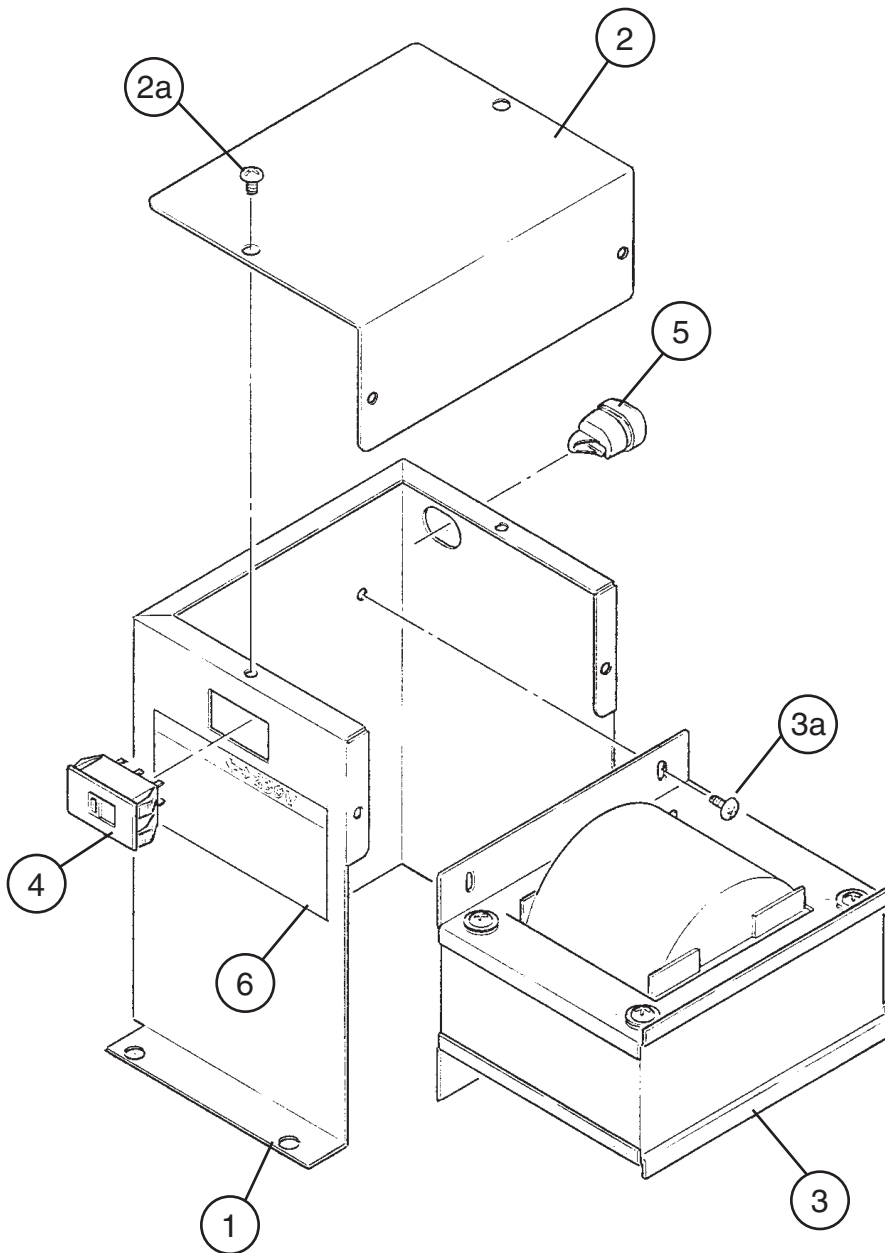

Title: F. Transformer Box Assembly Model: KM-1601MRH3					Required Number								
Index No.	Description	Material or Model Number	Part Number	Q-0									
				1	Transformer Box	-	3A1101-01	1					
2	Transformer Box Cover	-	438467-01	1									
2a	T2 Screw	4x8	7P31-0408	4									
3	Transformer	-	4A0817-01	1									
3a	Truss Head Screw	4x8	7C31-0408	4									
4	Slide Switch	-	4A1477-01	1									
5	Bushing	SR-30-1	420472-03	1									
6	Manual Label – Tap Switch	PVC FILM	439423-01	1									

**G. Evaporator**  
**KM-1601MRH, MRH3**  
 Q-0

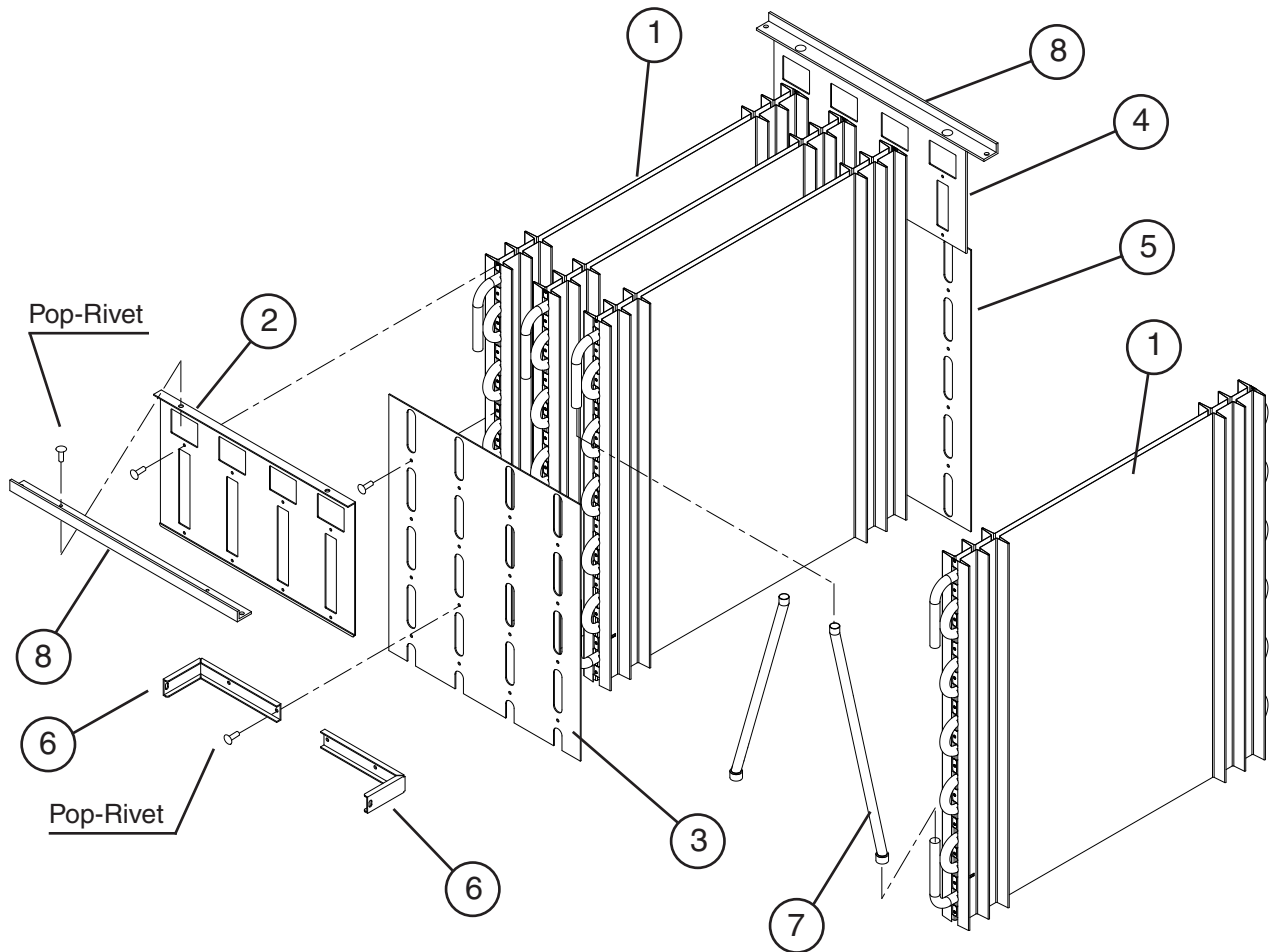

Title: G. Evaporator Model: KM-1601MRH, MRH3															
Index No.	Description	Material or Model Number	Part Number	Required Number											
				Q-0											
1	Evaporator	S-0428	103317G01	4											
2	Evap. Bracket (A)	SS	322700-01	1											
3	End Plate (A)	ABS	322842-01	1											
4	Evap. Bracket (B)	SS	322701-01	1											
5	End Plate (B)	ABS	322843-01	1											
6	Evap. Bracket (C)	GS	4A0659-01	2											
7	Copper Tube	COPPER	434320-01	2											
8	Frame – Evap.	GS	435062-01	2											

# H. Pump Motor Assembly

## KM-1601MRH, MRH3

Q-0

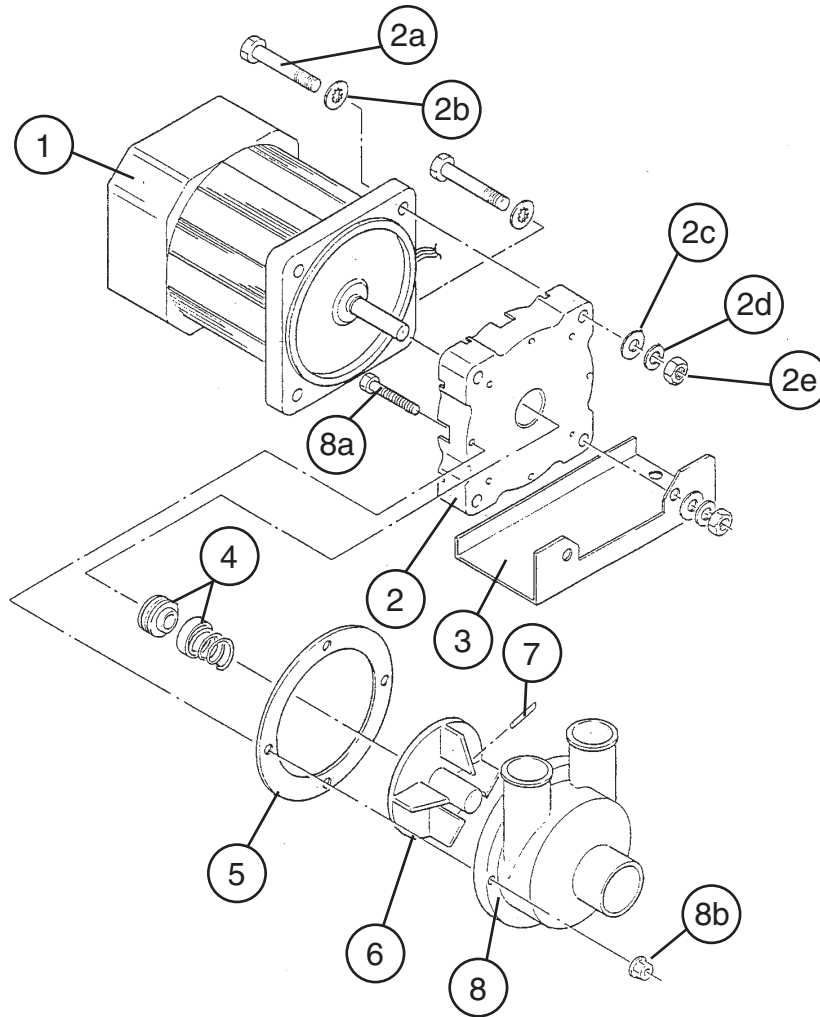

Title: **H. Pump Motor Assembly** Model: **KM-1601MRH, MRH3**

Index No.	Description	Material or Model Number	Part Number	Required Number																
				Q-0																
1	Pump Motor	M91A60SP201	2U0106-01	1																
2	Pump Flange	PC	215662-01	1																
2a	Hexagon Bolt	SS, 6x40	7B02-0640	4																
2b	Tooth Washer	SS, M6	7R22-0600	1																
2c	Flat Washer	SS, M6	7F22-0600	4																
2d	Split Lock Washer	SS, M6	7L22-0600	4																
2e	Nut	SS, M6	7N12-0600	4																
3	Pump Motor Bracket	SS	435057-01	1																
4	Mechanical Seal	H5-PN, 8MM	428545-01	1																
5	Packing	EPDM	428547-01	1																
6	Impeller	ABS	428548-01	1																
7	Pin	SS	4A0648-01	1																
8	Pump Housing	ABS	212636-01	1																
8a	Hexagon Bolt	SS, 4x30	7B02-0430	4																
8b	Flange Nut	SS, M4	7J02-0400	4																

**J. Accessories**  
**KM-1601MRH, MRH3**  
 Q-0

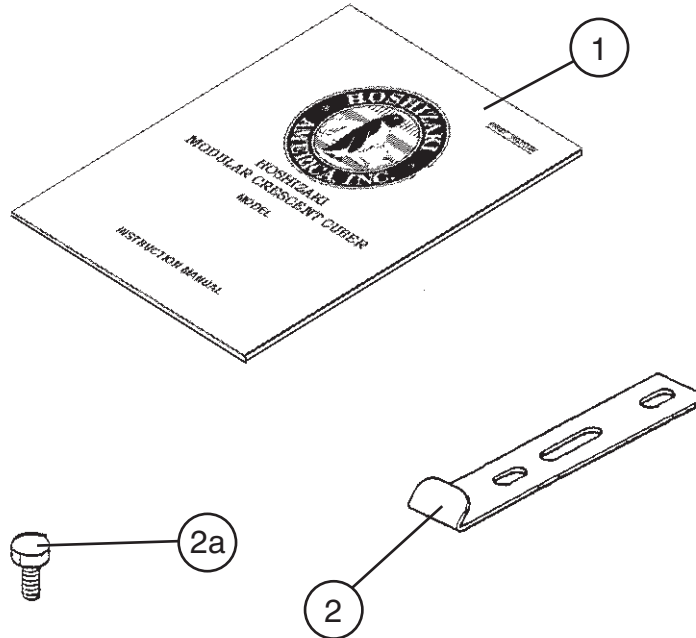

Title: J. Accessories Model: KM-1601MRH, MRH3											
Index No.	Description	Material or Model Number	Part Number	Required Number							
				Q-0							
1	Instruction Manual	PAPER	91A1FE10A	1							
2	Universal Brace	GS	4A0363-01	2							
2a	Hex Head Bolt	SS, 5x12	7B02-0512	2							