

Owner's Manual

Outdoor/Indoor
Refrigerator

ZDOD240



Monogram®

Introduction

Your new Monogram outdoor/indoor refrigerator makes an eloquent statement of style, convenience and kitchen planning flexibility. Whether you chose it for its purity of design or the assiduous attention to detail, you will find that your Monogram outdoor/indoor refrigerator's superior blend of form and function will delight you for years to come.

The information on the following pages will help you operate and maintain your outdoor/indoor refrigerator properly.

If you have any other questions, visit our Website at: **ge.com**

Contents

| | | | |
|--------------------------------------|--------|--------------------------------|------------|
| Built-In Dimensions/Clearances . . . | 14, 15 | Problem Solver | 16-18 |
| Care and Cleaning | 12, 13 | Product Registration | 2 |
| Consumer Services | 19 | Repair Service | 4, 19 |
| Controls and Features | 9-11 | Safety Instructions | 5-8 |
| Model and Serial Numbers | 2 | Warranty | Back Cover |

Before using your outdoor/indoor refrigerator

Read this manual carefully. It is intended to help you operate and maintain your new outdoor/indoor refrigerator properly.

Keep it handy for answers to your questions.

If you don't understand something or need more help, there is a list of toll-free consumer service numbers included in the back section of this manual.

OR

Visit our Website at: **ge.com**

Write down the model & serial numbers

You will find them on a label on the ceiling inside the outdoor/indoor refrigerator.

Please write these numbers here:

Model Number

Serial Number

Use these numbers in any correspondence or service calls concerning your outdoor/indoor refrigerator.

Consumer Information

Outdoor/Indoor Refrigerator

If you received a damaged appliance

The warranty does not cover damage caused after delivery.

Immediately contact the dealer (or builder) that sold you the outdoor/indoor refrigerator.

Save time & money

Before you request service, check the Problem Solver in the back of this manual.

It lists causes of minor operating problems that you can correct yourself.

Remove packaging

Before using, be sure all packing materials and tape have been removed.

To assure no damage is done to the finish of the product, the safest way to remove the adhesive left from packaging tape

on new appliances is an application of household liquid detergent. Apply with a soft cloth and allow to soak. Wipe dry and then apply an appliance polish to thoroughly clean and protect the surface.

Caring for your stainless steel

Stainless Steel—We strongly advise applying a commercially available stainless steel cleaner such as Stainless Steel Magic™ to preserve and protect the fine finish monthly.

The following substances and naturally occurring materials will cause damage to all stainless steel finishes. Care must be taken not to allow these substances to come in contact with your outdoor/indoor refrigerator. If any of these do get on your unit, wash and rinse immediately (see Care and Cleaning).

- Battery acid
 - Pool chemicals (such as chlorine and bromine)
 - Lawn fertilizer
 - Ice melting salts
 - Creosote
 - Iodine
 - Pickling juice
 - Urine
 - Bird droppings
 - Tree sap
 - Sea water
-

Safety considerations for outdoor applications

Use this appliance only for its intended use as described in this manual.

- Do not operate the unit where the temperature will go below 45°F (7.2°C) or above 120°F (49°C) (see Unit ON/OFF).
- Ensure the outdoor/indoor refrigerator is not installed in a location prone to standing water.
- Choose a level location that can withstand 250 lbs.
- Route the power cord so that it does not present a trip hazard.
- Surface can be hot in direct sunlight conditions. Use caution.

- Ensure the chosen location does not present a tip-over situation.
- Make sure dishes cool prior to storing them in the outdoor/indoor refrigerator. Certain types of glass, ceramic, earthenware or other glazed utensils retain heat. Hot dishes can cause the cold glass shelves to break.
- The use of a GE Vacuum Break (service part #'s WR49X403 and WR49X10026) is not authorized on the outdoor/indoor refrigerator.

If you need service

To obtain service, see the Consumer Services page in the back of this manual.

We are proud of our service and want you to be pleased. If for some reason you are not happy with the service you receive, here are steps to follow for further help.

For customers in the USA:

FIRST, contact the people who serviced your appliance. Explain why you are not pleased. In most cases, this will solve the problem.

NEXT, if you are still not pleased, write all the details—including your phone number—to:

Manager, Customer Relations
GE Appliances
Appliance Park
Louisville, KY 40225

For customers in Canada:

FIRST, contact the people who serviced your appliance. Explain why you are not pleased. In most cases, this will solve the problem.

NEXT, if you are still not pleased, write all the details—including your phone number to:

Manager, Consumer Relations
Camco Inc.
1 Factory Lane, Suite 310
Moncton, N.B. E1C 9M3

After installation is completed

- Promptly inspect your new Monogram outdoor/indoor refrigerator. If it has been damaged, contact the Installer or Dealer immediately.
- This outdoor/indoor refrigerator must be properly leveled to ensure correct door alignment and door closure. Contact the Installer if the unit is not level.
- The unit should be centered in the opening. In a standard 24" opening, the door will protrude 1-1/2" forward of adjacent cabinetry. Contact the installer if clearance is not correct.

- Test the door swing. Carefully open and close the door. The door should not rub or catch on adjacent cabinetry. Notify the installer if the door makes contact with cabinetry.

Please Contact the Installer or Dealer if you experience any of these problems.

IMPORTANT SAFETY INSTRUCTIONS

READ AND SAVE THESE INSTRUCTIONS

▲WARNING: When using this appliance, always exercise basic safety precautions, including the following:

- **Use this appliance only for its intended purpose** as described in this Owner's Manual.
- **This outdoor/indoor refrigerator must be properly installed in accordance with the Installation Instructions before it is used.**
- **Do not allow children to climb, stand or hang on the shelves in the outdoor/indoor refrigerator.** They could damage the outdoor/indoor refrigerator and seriously injure themselves.
- **Do not store or use gasoline or other flammable vapors and liquids in the vicinity of this or any other appliance.**

- **Keep fingers out of the “pinch point” areas:** clearances between the door and between the door and cabinet are necessarily small. Be careful closing the door when children are in the area.
- **Unplug or turn off your outdoor/indoor refrigerator before cleaning or making repairs.**

NOTE: We strongly recommend that any servicing be performed by a qualified individual.

- **Before replacing a burned-out light bulb,** the outdoor/indoor refrigerator should be turned OFF or unplugged in order to avoid contact with a live wire filament. (A burned-out light bulb may break when being replaced.)

▲DANGER: *RISK OF CHILD ENTRAPMENT*

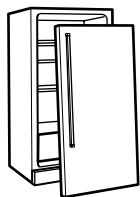

Child entrapment and suffocation are not problems of the past. Junked or abandoned refrigeration products are still dangerous...even if they will sit for “just a few days.” If you are getting rid of your old appliance, please follow these instructions to help prevent accidents.

Before You Throw Away Your Old Refrigeration Product:

- Take off the doors.
- Leave the shelves in place so that children may not easily climb inside.

REFRIGERANTS

All refrigeration products contain refrigerants, which under federal law must be removed prior to product disposal.

If you are getting rid of an old refrigeration product, check with the company handling the disposal about what to do.

INSTRUCTIONS IMPORTANTES DE SÉCURITÉ

LIRE ET CONSERVER CES INSTRUCTIONS

▲ AVERTISSEMENT :

Lorsque vous utilisez l'appareil, observez toujours certaines précautions de base, notamment :

- **N'utilisez l'appareil que pour son usage prévu**, comme décrit dans le présent manuel.
- **Installez le réfrigérateur intérieur/extérieur conformément aux directives d'installation avant de l'utiliser.**
- **Ne laissez pas les enfants grimper, s'asseoir, se tenir debout ni se pendre aux clayettes du réfrigérateur intérieur/extérieur.** Ils pourraient endommager le réfrigérateur et se blesser gravement.
- **N'entreposez et n'utilisez pas d'essence ou autres vapeurs et liquides inflammables à proximité de cet appareil ou de tout autre appareil électroménager.**

- **Éloignez les doigts des parties du réfrigérateur où l'on peut facilement se pincer :** les espaces entre les portes et entre les portes et les placards sont toujours étroits. Soyez prudent lorsque vous fermez les portes de l'appareil en présence des enfants.
- **Débranchez ou fermez votre réfrigérateur intérieur/extérieur avant de le nettoyer et de le réparer.**

REMARQUE : Nous vous recommandons vivement de confier toute réparation à un technicien qualifié.

- **Avant de remplacer une ampoule grillée,** le réfrigérateur intérieur/extérieur doit être débranché afin d'éviter tout contact avec un fil sous tension. (Une ampoule grillée peut se briser pendant l'opération).

▲ DANGER : RISQUES POUR LES ENFANTS

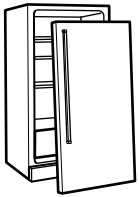

Les enfants pris au piège ou morts d'asphyxie sont toujours d'actualité. Les appareils de réfrigération abandonnés sont toujours aussi dangereux, même si on n'attend que "quelque jours" pour s'en débarrasser. Si vous ne gardez pas votre ancien appareil, veuillez suivre les directives ci-dessous afin de prévenir les accidents.

Avant de vous débarrasser de votre vieux appareil de réfrigération :

- Démontez les portes.
- Laissez les clayettes en place afin d'empêcher les enfants de grimper à l'intérieur.

RÉFRIGÉRANTS

Tous les appareils de réfrigération contiennent des réfrigérants qui, conformément aux lois fédérales, doivent être enlevés avant toute élimination de l'appareil.

Si vous vous débarrassez de vieux appareils de réfrigération, vérifiez, auprès de la société qui s'occupe de leur élimination, ce que vous devez faire.

IMPORTANT SAFETY INSTRUCTIONS

HOW TO CONNECT ELECTRICITY



▲WARNING:

THIS PRODUCT MUST BE CONNECTED TO A POWER SOURCE WITH GROUND FAULT CIRCUIT INTERRUPT (GFCI) PROTECTION WHEN INSTALLED IN AN OUTDOOR LOCATION. LOCAL CODES MAY REQUIRE A SEPARATE CIRCUIT.

IF YOU ARE UNCERTAIN ABOUT THE GFCI PROTECTION ON THE POWER SOURCE TO WHICH YOU ARE CONNECTING THIS APPLIANCE, PLEASE CONTACT A PROFESSIONAL ELECTRICIAN FOR VERIFICATION.

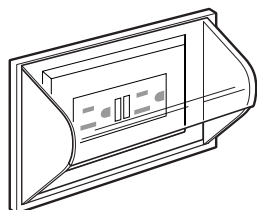

Refrigerator MUST be plugged into a functioning GFCI circuit. Test your circuit by plugging your refrigerator into the outlet and pressing the test button for that circuit, verifying that the unit turns off (the light will not work with the door open). Then press the Reset button and confirm that the light comes on with the door open. If you do not know if you have a GFCI circuit, contact a qualified electrician for assistance.

Where a standard 2-prong electrical outlet is encountered, it is your personal responsibility and obligation to have it replaced with a properly grounded 3-prong wall outlet.

The appliance should always be plugged into its own individual electrical outlet which has a voltage rating that matches the rating plate. This provides the best performance and also prevents overloading house wiring circuits which could cause a fire hazard from overheated wires.

Never unplug an appliance by pulling on the power cord. Always grip the plug firmly and pull straight out from the outlet.

Repair or replace immediately all power cords that have become frayed or otherwise damaged. Do not use a cord that shows cracks or abrasion damage along its length or at either end.

When moving the appliance, be careful not to roll over or damage the power cord.

Do not place the unit in standing water or allow the power cord to be immersed.

Do not, under any circumstances, cut or remove the third (ground) prong from the power cord. For personal safety, this appliance must be properly grounded.

The power cord of this appliance is equipped with a 3-prong (grounding) plug which mates with a standard 3-prong (grounding) wall outlet to minimize the possibility of electric shock hazard from this appliance.

Have the electrical outlet and circuit checked by a qualified electrician to make sure the outlet is properly grounded.

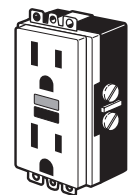

DO NOT USE AN ADAPTER PLUG OR EXTENSION CORD

(Adapter plugs not permitted in Canada)



Do not use an adapter plug to connect the refrigerator to a 2-prong outlet.

Do not use an extension cord with this appliance.

SAVE THESE INSTRUCTIONS

INSTRUCTIONS IMPORTANTES DE SÉCURITÉ

RACCORDEMENT ÉLECTRIQUE



▲ AVERTISSEMENT :

CE PRODUIT DOIT ÊTRE CONNECTÉ À UNE SOURCE D'ALIMENTATION À DISJONCTEUR DE FUITE À LA TERRE, EN CAS D'INSTALLATION EN PLEIN-AIR. LES RÉGLEMENTATIONS LOCALES PEUVENT EXIGER UN CIRCUIT DISTINCT.

EN CAS DE DOUTE SUR LA PROTECTION ASSURÉE PAR LE DISJONCTEUR DE FUITE À LA TERRE SUR LA SOURCE D'ALIMENTATION À LAQUELLE VOUS CONNECTEZ CET APPAREIL, VEUILLEZ FAIRE VÉRIFIER L'INSTALLATION PAR UN ÉLECTRICIEN PROFESSIONNEL.

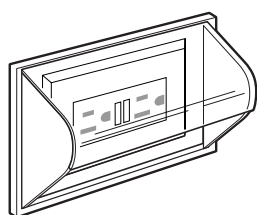

Vous DEVEZ brancher votre réfrigérateur à un circuit avec interrupteur de défaut à la terre.

Essayez votre circuit en branchant votre réfrigérateur dans la prise et en appuyant sur le bouton d'essai pour ce circuit, en vous assurant que le réfrigérateur ne reçoit plus de courant (la lumière du réfrigérateur ne s'allume pas quand vous ouvrez la porte). Appuyez ensuite sur le bouton Reset (remise à zéro) et vérifiez que la lumière s'allume quand vous ouvrez la porte. Si vous ne savez pas si votre circuit est équipé d'un interrupteur de défaut à la terre, demandez à un électricien qualifié de vous aider.

Si la prise de courant est du type standard à 2 alvéoles, il vous incombe de la faire remplacer par une prise à 3 alvéoles correctement mise à la terre.

L'appareil doit toujours être branché dans sa propre prise de courant, dont la tension nominale est identique à celle indiquée sur la plaque signalétique.

Cette précaution est recommandée pour garantir un rendement optimum et éviter une surcharge des circuits électriques de la résidence, ce qui pourrait créer un risque d'incendie par surschauffe des fils.

Ne débranchez jamais l'appareil en tirant le cordon d'alimentation. Saisissez fermement la fiche du cordon et tirez droit pour la retirer de la prise.

Réparez ou remplacez immédiatement tout cordon effiloché ou endommagé. N'utilisez pas un cordon fendillé ou présentant des signes d'usure.

Lorsque vous déplacez l'appareil, faites attention de ne pas la faire rouler sur le cordon d'alimentation afin de ne pas l'endommager.



N'immergez jamais votre appareil dans de l'eau, ni son cordon d'alimentation.

Ne coupez ni retirez en aucun cas la troisième broche (mise à la terre) de la fiche du cordon d'alimentation. Pour votre sécurité, cet appareil doit être correctement mis à la terre.

Le cordon d'alimentation de cet appareil est muni d'une fiche à 3 broches (mise à la terre) qui se branche dans une prise mural ordinaire à 3 alvéoles (mise à la terre) pour réduire au minimum les risques du chocs électriques.

Faites examiner la prise de courant et le circuit par un électricien qualifié pour vous assurer que la prise est correctement mise à la terre.

NE PAS UTILISER DE FICHE D'ADAPTATION OU DE CORDON PROLONGATEUR

(Fiches d'adaptation non permises au Canada)



N'utilisez pas de fiche d'adaptation pour brancher le réfrigérateur dans une prise à 2 broches.

N'utilisez pas de cordon prolongateur avec cet appareil.

CONSERVEZ CES DIRECTIVES

Temperature control

The temperature display shows the actual temperature of the outdoor/indoor refrigerator. The actual temperature may vary slightly from the set temperature based on factors such as door opening, amount of food and outside temperature.

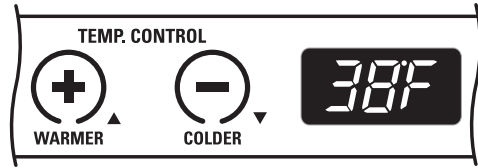

To change the temperature setting, press the WARMER or COLDER pads until you reach the desired set temperature. After several seconds, the display will return to the actual temperature.

Allow 12–24 hours for the outdoor/indoor refrigerator to reach the temperature that you have set.

Temperature Settings

Minimum: 34°F (1.1°C)

Maximum: 45°F (7.2°C)

Child control lockout

This child control lockout feature prevents unwanted changes to your temperature settings.

After the desired temperature is set, the temperature can be locked. To lock, press both the + and – pads at the same time for five seconds. To unlock, press both + and – pads for five seconds.

Unit ON/OFF

This pad stops cooling in the outdoor/indoor refrigerator, turns off the temperature controls and removes power to the light circuit.



Press this pad for a minimum of 3 seconds to turn the outdoor/indoor refrigerator OFF for long vacations or absences, or when cleaning the unit or changing the light bulb. Press the pad again to turn the outdoor/indoor refrigerator ON.

Key ejecting lock

Keep the keys out of reach of children. Store the keys in a safe place.

Keys for the spring-loaded lock are automatically ejected. Keys will not remain in the lock while the door is opened or closed.

NOTE: Two keys are included.

CAUTION: Before closing the door, make sure the lock pin does not protrude beyond the top of the door, to prevent potential damage to the cover or cabinetry.

Interior fan

The interior fan is located in the rear wall of the outdoor/indoor refrigerator and is designed to run continuously to help maintain the proper cooling temperature. The interior fan will only turn off when the door is opened.

Glass shelves

Tempered glass shelves in the outdoor/indoor refrigerator are removable for easy cleaning or for storing larger items.

To remove a shelf, open the door completely to avoid potential damage to the gasket. Lift up on the back of the shelf slightly. Tilt the shelf to one side at an angle while pulling forward.

To replace a shelf, open the door completely to avoid potential damage to the gasket. Tilt the shelf to one side at an angle and slide toward the back wall, placing one side onto the shelf support. Place the other side onto the opposite shelf support. Ensure rear locking tabs are engaged. When installed properly, the shelf will not slide forward when gently pulled.

Appearance may vary

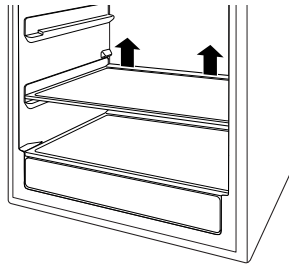

To remove, lift up on the back of the shelf

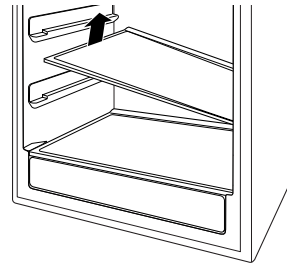

Tilt the shelf at an angle while removing or replacing

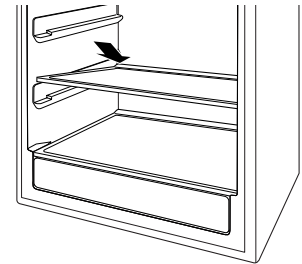

Place in slots when replacing the shelf

QuickSpace™ Shelf

This shelf splits in half and slides under itself for storage of tall items on the shelf below.

Step 1: Lift the back edge of the front half of the shelf.

Step 2: Pull slightly forward.

Step 3: Lower the back edge of the front half of the shelf while sliding it underneath the back half.

The entire Quick Space shelf can be removed and replaced (see Glass Shelves section).

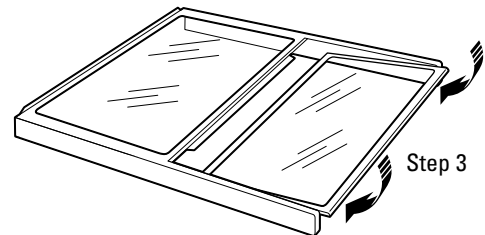
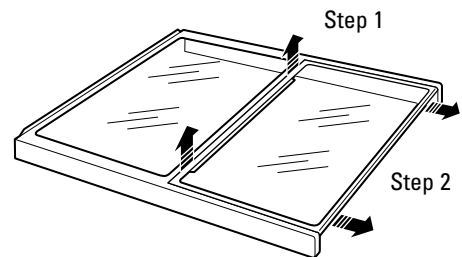

Loading tips and suggestions

The bottom two full extension drawers hold five bottles each and are loaded with necks facing the rear. Tall bottles should not be loaded on the bottom drawer because they may prevent the door from closing.

- **Do not block the thermistor**, located on the right-hand side, just above the third shelf of the outdoor/indoor refrigerator. Blocking the thermistor could impair the air circulation and temperature control.

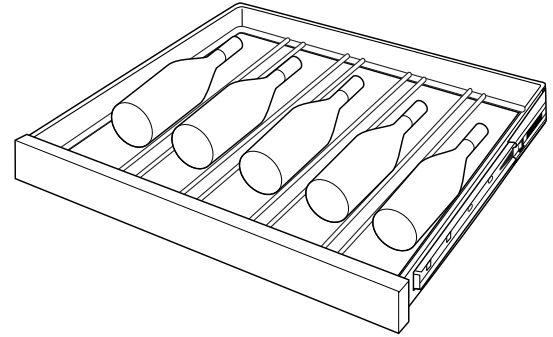

Bottom drawer arrangement

Removing full extension drawers

The bottom full extension drawers pull out so bottles can conveniently be added or removed.

The upper full extension slide can be removed for magnums or larger bottles.

To remove:

1. Pull the full extension drawer out to the STOP position.
2. Push the tab on right drawer guide down while pulling the tab on left guide up, and pull the drawer out.

To replace:

1. Push the drawer slide arm back into the unit.
2. Pull the small slide sub-assembly completely forward.
3. Insert the sides of the drawer back into the guides.
4. Push until the tabs lock into place.

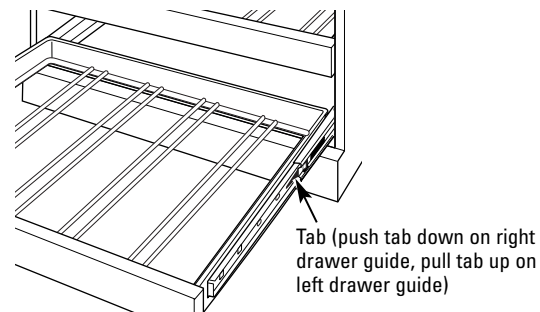

Appearance may vary

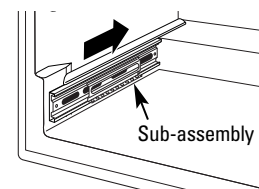

To replace, push drawer slide arm back into unit

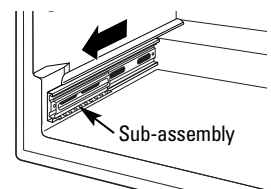

Pull small slide sub-assembly completely forward

NOTE: Make sure the tabs on the full extension drawer guides are fully engaged before loading any bottles. Pull the drawers out all the way to the STOP position and push back in several times to make sure locking tabs are properly engaged.

Wood drawer fronts

The full extension drawer fronts on the outdoor/indoor refrigerator are unfinished cherry wood. During use, oil from hands may accumulate and stain the wood.

- The drawer fronts may be stained and sealed to match adjacent cabinetry.

- Apply the stain and sealer according to the manufacturer's instructions. To avoid unpleasant odor, keep the door open to ventilate and allow the stain/sealer to dry completely before using the product.

NOTE: Natural wood may vary slightly in grain and color.

Care and Cleaning

Outdoor/Indoor Refrigerator

For your safety

Turn the outdoor/indoor refrigerator OFF or unplug the unit before cleaning.

Turn the outdoor/indoor refrigerator OFF by pressing the button on the control panel a minimum of 3 seconds until the light and temperature display turn off.

Door gasket

The vinyl gasket may be cleaned with mild soap and water, a baking soda solution or a mild scouring powder. Rinse well.

After cleaning the door gasket, apply a thin layer of paraffin wax or petroleum jelly to the door gasket at the hinge side. This helps keep the gasket from sticking and bending out of shape.

Light bulb replacement

Turn OFF or unplug the outdoor/indoor refrigerator before replacing the light bulb.

To remove the light shield, push in the tab on the left side of the shield and lower it. Replace with a 15 watt appliance bulb.

In the event of a power failure

If power fails, you can maintain interior temperature longer by keeping the door closed. Open the door only when necessary to avoid the loss of cold air.

Do not store or use gasoline or other flammable vapors and liquids in the vicinity of this or any other appliance.

Preparing for vacation

For long vacations or absences, always leave the unit running with the temperature set at 45°F (7.2°C). This will provide the greatest degree of protection to your outdoor/indoor refrigerator. In addition to leaving your unit turned on, it is recommended that you follow the below steps prior to long vacations. If you cannot leave your unit turned on during extended periods of non-use, be sure to follow the below steps.

1. Remove all the contents from the unit.
2. Clean the outside and inside (see instructions on the next page).
3. Place charcoal and baking soda inside the unit. In conditions which are either below 45°F (7.2°C) or high humidity, use 4 lbs. baking soda. In all other conditions, use 1 lb. baking soda.
4. Cover the unit with the Monogram vinyl cover.

A vinyl cover accessory is available to protect the outdoor/indoor refrigerator during extended periods of non-use. The durable vinyl exterior withstands the elements and the soft felt lining helps protect the stainless steel finish. There is one that fits a built-in installation or one for free-standing use. In addition to the vinyl cover, an embroidered Monogram polishing cloth is available. Use the polishing cloth to keep the refrigerator's stainless steel finish clean.

ZBKTF – for free-standing installation
ZBKTB – for built-in installation
ZPOL – for Monogram polishing cloth

Call 800.626.2002 to order.

For shorter vacations, remove perishable foods and leave controls at regular settings. However, if the ambient temperature is expected to drop below 45°F (7.2°C), follow the same instructions as for long vacations.

Preparing to move

Secure all loose items such as shelves and drawers by taping them securely in place to prevent damage.

Be sure the outdoor/indoor refrigerator stays in an upright position during moving.

For your safety

Turn the outdoor/indoor refrigerator OFF or unplug the unit before cleaning.
Turn the outdoor/indoor refrigerator OFF by pressing the button on the control panel a minimum of 3 seconds until the light and temperature display turn off.

Cleaning the outside

Your new stainless steel Monogram unit can maintain its new luster for the life of the product if maintained as described below.

Keep the outside clean. Regularly polish the stainless steel exterior and handle with Stainless Steel Magic™ and the Monogram polishing cloth, to preserve and protect the fine finish. Do not apply to plastic and rubber components.

To avoid scratching the fine finish of the stainless steel, wipe in the same direction as the grain when polishing or cleaning any stainless steel surface. The grain on the outdoor/indoor refrigerator runs top to bottom on all sides and front to back on the top canopy.

For regular cleaning, use clean water and a soft cloth. If stains persist, wash with mild dish soap using a soft cloth or non-abrasive pad. For more difficult stains, make a solution consisting of 25% vinegar (white or red) and 75% water. Dip a soft cloth into the solution and rub onto the stainless steel to remove the stain. If these methods do not remove the stains, dirt or debris, call 800.GE.CARES.

NOTE: Always reapply Stainless Steel Magic with the Monogram polishing cloth after cleaning or if your unit comes in contact with water, to protect the fine finish.

Stainless Steel Magic and additional Monogram polishing cloth are available

through GE Parts and Accessories, 800.626.2002 or ge.com.

For Stainless Steel Magic, order part number WX10X15. For Monogram polishing cloth, order part number ZPOL.

Always remove any debris or obstruction from the front of the toe-kick to ensure optimum performance.

Do not use appliance wax or polish on any stainless steel surface.

Do not use scouring pads, powdered cleaners, bleach or cleaners containing bleach because these products can scratch and damage the finish.

Warranty does not cover damage due to improper cleaning methods.

Recommended cleaning is determined by the installation location. Use this chart to determine the frequency for cleaning your outdoor/indoor refrigerator.

| Environment | Stainless Steel Magic™ | Clean Drain | Clean Gasket (add petroleum / wax to hinge side of gasket) |
|-------------------------|------------------------|----------------|--|
| Near Pool and Saltwater | Weekly | Every 6 months | Every 6 months |
| Near Pool | Every other week | | |
| Near Saltwater | Every other week | | |
| High Humidity | Monthly | | |
| All Others | Every other month | | |

Cleaning the inside

Unplug the outdoor/indoor refrigerator before cleaning. If this is not practical, turn the unit OFF and wring excess moisture out of the cloth or sponge when cleaning around switches, lights or controls.

Use warm water and baking soda solution—about a tablespoon (15 ml) of baking soda to a quart (1 liter) of water. This both cleans and neutralizes odors. Thoroughly rinse and wipe dry.

Other parts of the outdoor/indoor refrigerator—including the door gaskets, full extension drawers and glass shelves—can be cleaned the same way.

Avoid cleaning cold glass shelves with hot water because the extreme temperature difference may cause them to break. Handle glass shelves carefully. Rough handling of tempered glass can cause it to shatter.

Drain hole

Periodically check the drain hole and channel for any debris. If the drain is blocked, condensation will not drain properly.

To check and clean the drain hole, remove the bottom two glass shelves. Sweep a damp cloth along the channel in the back of the outdoor/indoor refrigerator. Use a finger to sweep away any debris from the drain hole.

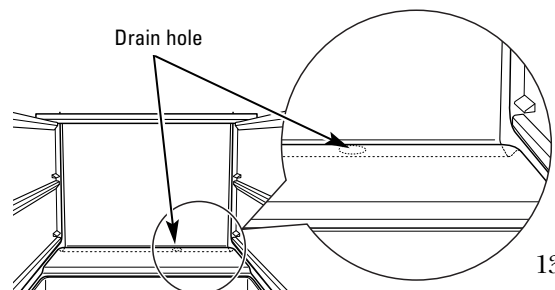

Built-In Dimensions

Outdoor/Indoor Refrigerator

Installation dimensions

The outdoor/indoor refrigerator can be a free-standing model or can be built in using the cut-out dimensions below.

When building in the outdoor/indoor refrigerator, be sure to allow for a full door swing so you have full access to the pull-out full extension drawers.

See the Installation Instructions (Pub. No. 31-51542) for complete directions.

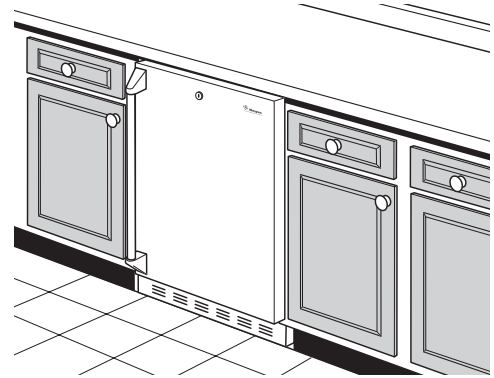
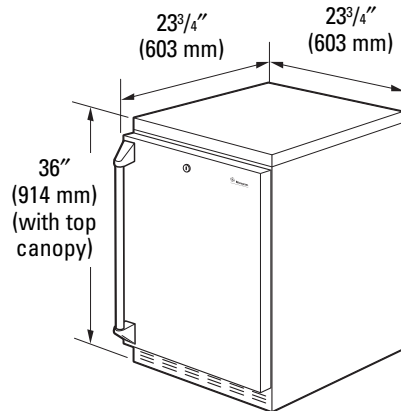

Product dimensions:

Height with canopy: 36" (914 mm)
Height without canopy: 34¹/₂" (876 mm)
Width: 23³/₄" (603 mm)
Depth: 23³/₄" (603 mm)

NOTE:

Handle and handle standoff depth is 2³/₄"

Cut-out dimensions:

Height: 34¹/₂" (876 mm) minimum
Width: 23³/₄" (603 mm) minimum
Depth: 24" (610 mm)

Top canopy removal

The top canopy may be removed when installing under a countertop.

The door **MUST BE** closed when removing or replacing the top canopy. To avoid damage, the top canopy must clear the left hinge center locking plate and right hinge.

- Remove the 3 screws from the back of the top canopy (A).
- Using heavy-duty work gloves, lift up on the top canopy back (B) and slide it forward until it unlatches from the unit (C).
- Lift the top canopy up and off of the unit.

NOTE: Keep the top canopy and screws for future free-standing installations.

NOTE: When installing the unit in a free-standing configuration, the top canopy must be left in place.

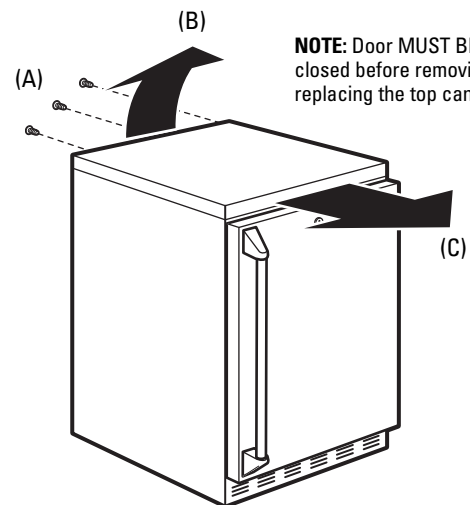

NOTE: Door **MUST BE** closed before removing or replacing the top canopy.

CAUTION: Under side edges of the stainless steel canopy top may be sharp. Wear heavy-duty work gloves when moving the top.

Built-In Dimensions

Outdoor/Indoor Refrigerator

Product clearances

The outdoor/indoor refrigerator is factory set for a 110° door swing.

When installed in a corner:

- Allow 5-1/4" minimum clearance on the **hinge side** for the 90° door swing and to allow racks to slide out.
- Allow 15" minimum clearance on the **hinge side** for a full 110° door swing.

Choose the location:

- These products may be closed in on the top and three sides as long as the front is unobstructed for air circulation and proper access to the door.
- Do not operate these products where the temperature will go below 45°F (7.2°C) or above 120°F (49°C) (see Unit ON/OFF).

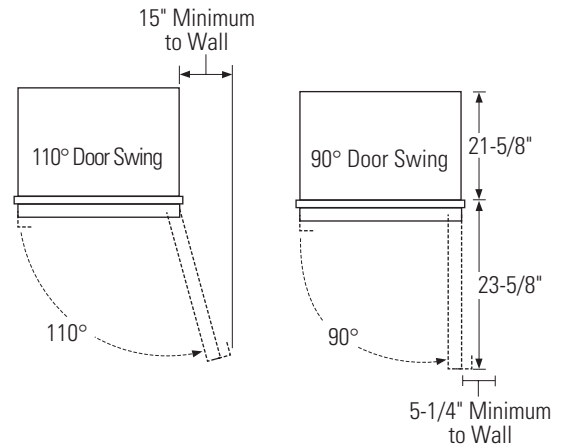

Normal operating sounds

Newer appliances sound different from older appliances. Modern appliances have more features and use newer technology.

Do you hear what I hear? These sounds are normal.

HUMMM... WHOOSH...

- The new high efficiency compressor may run faster and longer than your old appliance and you may hear a high-pitched hum or pulsating sound while it is operating.
- Sometimes the appliance runs for an extended period, especially when the doors are opened frequently.
- You may hear a whooshing sound when the doors close. This is due to pressure equalizing within the appliance.
- The interior fan runs continuously except when the door is opened.



- You may hear the fans spinning at high speeds. This happens when the appliance is first plugged in, when the door is opened frequently or when a large amount of food is added to the appliance. The fans help maintain desired temperatures.
- If the door is open for over 3 minutes, you may hear the fans come on in order to cool the light bulbs.
- The fans change speeds in order to provide optimal cooling and energy savings.

CLICKS, POPS, CRACKS and CHIRPS

- You may hear cracking or popping sounds when the appliance is first plugged in. This happens as the appliance cools to the correct temperature.
- The electronic control board may cause a clicking sound when relays activate to control appliance components.
- Expansion and contraction of cooling coils during and after defrost can cause cracking or popping sounds.

WATER SOUNDS



- The flow of refrigerant through the freezer cooling coils may make a gurgling noise like boiling water.
- Water dropping on the defrost heater can cause a sizzling, popping or buzzing sound during the defrost cycle.
- A water dripping noise may occur during the defrost cycle as ice melts from the evaporator and flows into the drain pan.
- Closing the door may cause a gurgling sound due to pressure equalization.

The Problem Solver

Outdoor/Indoor Refrigerator

*Questions?
Use this
problem
solver!*

| PROBLEM | POSSIBLE CAUSE |
|---|---|
| APPLIANCE DOES NOT OPERATE | <ul style="list-style-type: none"> • Appliance is so quiet that most of the time you will hear low or no operating noise. • Appliance may be in defrost cycle when compressor motor does not operate for about 30 minutes. • Controls are set to OFF. Press ON/OFF button on control panel. • If interior light is not on, appliance may not be plugged in at electrical outlet. Push the plug completely into the electrical outlet. • The GFCI circuit breaker is tripped. Replace fuse or reset the breaker. • The appliance is in showroom mode. Unplug it and plug it back in. |
| VIBRATION OR RATTLING (Slight vibration is normal.) | <ul style="list-style-type: none"> • Adjust the leveling legs as shown in the Installation Instructions. |
| COMPRESSOR MOTOR OPERATES FOR LONG PERIODS OR CYCLES ON AND OFF FREQUENTLY | <ul style="list-style-type: none"> • Normal when appliance is first plugged in. Wait 24 hours for the appliance to completely cool down. • Often occurs when large amounts of food are placed in appliance. This is normal. • Door left open or package holding door open. • Hot weather or frequent door openings. This is normal. • Temperature control set at the coldest setting. See Temperature Control. |
| COMPARTMENT TOO WARM | <ul style="list-style-type: none"> • Temperature control not set cold enough. See Temperature Control. Allow 12–24 hours for temperature to change. • Warm weather or frequent door openings. • Door left open for long time. • Package may be holding door open. • Thermistor may be blocked, which can affect the overall temperature. The thermistor is located on the right hand side just above the third shelf. |
| APPLIANCE HAS ODOR | <ul style="list-style-type: none"> • Interior needs cleaning. See Care and Cleaning. • Keep open box of baking soda in appliance; replace every 3 months. |
| DOOR NOT CLOSING PROPERLY | <ul style="list-style-type: none"> • Door gasket is sticking or folding over. Apply petroleum jelly or paraffin wax to the face of the gasket. • The door is hitting an internal component inside the appliance. Adjust interior components to prevent interference. |
| MOISTURE FORMS ON OUTSIDE OF APPLIANCE | <ul style="list-style-type: none"> • Not unusual during periods of high humidity. Wipe surface dry. • Door left open or package holding door open. |
| FROST OR MOISTURE COLLECTS INSIDE | <ul style="list-style-type: none"> • Too frequent or too long door openings. • In humid weather, air carries moisture into appliance when door is opened. • Temperature control is set at coldest setting. • Thermistor may be blocked, which can affect the overall temperature. The thermistor is located on the right hand side just above the third shelf. |

The Problem Solver

Outdoor/Indoor Refrigerator

*Questions?
Use this
problem
solver!*

| PROBLEM | POSSIBLE CAUSE |
|--|--|
| INTERIOR LIGHT DOES NOT WORK | <ul style="list-style-type: none">• No power at outlet.• Light bulb needs replacing. See Care and Cleaning.• Controls are set to OFF. Press ON/OFF pad on control panel. |
| HOT AIR FROM BOTTOM OF APPLIANCE | <ul style="list-style-type: none">• Normal air flow cools the motor. In the refrigeration process, it is normal that heat be expelled in the area under the appliance. Some floor coverings are sensitive and will discolor even at these safe and normal temperatures. |
| APPLIANCE NEVER SHUTS OFF BUT TEMPERATURES ARE OK | <ul style="list-style-type: none">• Adaptive defrost keeps compressor running during door openings. This is normal. The appliance will cycle off after the door remains closed for two hours.• Normal operation in extreme temperatures. |
| ACTUAL TEMPERATURE NOT EQUAL TO SET TEMPERATURE | <ul style="list-style-type: none">• Unit just plugged in. Allow 24 hours for the system to stabilize.• Door open for too long. Allow 24 hours for the system to stabilize.• Warm contents added to appliance. Allow 24 hours for the system to stabilize.• Defrost cycle is in process. Allow 24 hours for the system to stabilize.• Thermistor may be blocked, which can affect the overall temperature. The thermistor is located on the right hand side just above the third shelf. |
| TEMPERATURE WILL NOT ADJUST | <ul style="list-style-type: none">• Temperature may be in lockout mode. Press both + and – pads for 5 seconds to unlock the temperature.• Thermistor may be blocked, which can affect the overall temperature. The thermistor is located on the right hand side just above the third shelf. |

With the purchase of your new Monogram appliance, receive the assurance that if you ever need information or assistance from GE, we will be there. All you have to do is call—toll-free!

GE Answer Center®

***In the USA:
800.626.2000***

Whatever your question about any Monogram major appliance, GE Answer Center® information service is available to help. Your call—and your question—will be answered promptly and courteously. And you can call any time. GE Answer Center® service is open 24 hours a day, 7 days a week.

OR

Visit our Website at: **ge.com**

In Canada, call 1.888.880.3030.

In-Home Repair Service

***In the USA:
800.444.1845***

***In Canada:
1.888.880.3030***

A GE consumer service professional will provide expert repair service, scheduled at a time that's convenient for you. Many GE Consumer Service company-operated locations offer you service today or tomorrow, or at your convenience (7:00 a.m. to 7:00 p.m. weekdays, 9:00 a.m. to 2:00 p.m. Saturdays). Our factory-trained technicians know your appliance inside and out—so most repairs can be handled in just one visit.

For Customers With Special Needs...

***In the USA:
800.626.2000***

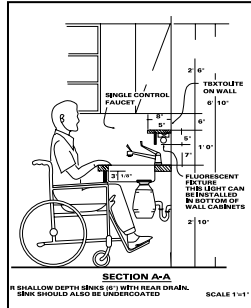

GE offers Braille controls for a variety of GE appliances, and a brochure to assist in planning a barrier-free kitchen for persons with limited mobility.

Consumers with impaired hearing or speech who have access to a TDD or a conventional teletypewriter may call 800.TDD.GEAC (800.833.4322) to request information or service.

Service Contracts

***In the USA:
800.626.2224***

***In Canada:
1.888.880.3030***

You can have the secure feeling that GE Consumer Service will still be there after your warranty expires. Purchase a GE contract while your warranty is still in effect and you'll receive a substantial discount. With a multiple-year contract, you're assured of future service at today's prices.

Parts and Accessories

***In the USA:
800.626.2002***

***In Canada:
1.888.880.3030***

Individuals qualified to service their own appliances can have parts or accessories sent directly to their home. The GE parts system provides access to over 47,000 parts...and all GE Genuine Renewal Parts are fully warranted. VISA, MasterCard and Discover cards are accepted.

User maintenance instructions contained in this manual cover procedures intended to be performed by any user. Other servicing generally should be referred to qualified service personnel. Caution must be exercised, since improper servicing may cause unsafe operation.

Warranty

Outdoor/Indoor Refrigerator

YOUR MONOGRAM OUTDOOR/INDOOR REFRIGERATOR WARRANTY ***Staple sales slip or canceled check here. Proof of original purchase date is needed to obtain service under warranty.***

WHAT IS COVERED

From the Date of the Original Purchase

LIMITED ONE-YEAR WARRANTY

For one year from date of original purchase, we will provide, free of charge, parts and service labor in your home to repair or replace *any part of the unit* that fails because of a manufacturing defect.

LIMITED FIVE-YEAR WARRANTY

For five years from date of original purchase, we will provide, free of charge, parts and service labor in your home to repair or replace *any part of the sealed refrigerating system* (the compressor, condenser, evaporator and all connecting tubing) that fails because of a manufacturing defect.

This warranty is extended to the original purchaser and any succeeding owner for products purchased for ordinary home use in the 48 mainland states, Hawaii, Washington, D.C. or Canada. If the product is located in an area where service by a GE Authorized Servicer is not available, you may be responsible for a trip charge or you may be required to bring the product to an Authorized GE Service location for service. In Alaska the warranty is the same except that it is LIMITED because you must pay to ship the product to the service shop or for the service technician's travel costs to your home.

All warranty service will be provided by our Factory Service Centers or by our authorized Customer Care® servicers during normal working hours.

Should your appliance need service, during warranty period or beyond, in the USA call 800.444.1845. In Canada: 888.880.3030. Please have your serial number and model number available when calling for service.

WHAT IS NOT COVERED

- Service trips to your home to teach you how to use the product.
- Replacement of house fuses or resetting of circuit breakers.
- Damage to the product caused by accident, fire, floods or acts of God.
- Failure of the product if it is used for other than its intended purpose or used commercially.
- Damage caused after delivery.
- Improper installation, delivery or maintenance. If you have an installation problem, contact your dealer or installer. You are responsible for providing adequate electrical, plumbing and other connecting facilities.
- Replacement of the light bulbs, if included.
- Loss of food due to spoilage (in the USA only).
- Incidental or consequential damage caused by possible defects with this appliance.
- Product not accessible to provide required service.

EXCLUSION OF IMPLIED WARRANTIES—Your sole and exclusive remedy is product repair as provided in this Limited Warranty. Any implied warranties, including the implied warranties of merchantability or fitness for a particular purpose, are limited to one year or the shortest period allowed by law.

Some states/provinces do not allow the exclusion or limitation of incidental or consequential damages, so the above limitation or exclusion may not apply to you. This warranty gives you specific legal rights, and you may also have other rights which vary from state to state/province to province. To know what your legal rights are in your state/province, consult your local or state/provincial consumer affairs office or your state's Attorney General.

**Warrantor in USA: General Electric Company,
Louisville, KY 40225**

Warrantor in Canada: Camco Inc.

197D5891P010

49-60432

11-05 JR

Printed in Slovenia



GE Consumer & Industrial
Appliances
General Electric Company
Louisville, KY 40225
ge.com