

TUNTURI®

OWNERS MANUAL



**AIRCYCLE
E603**

CONTENTS

Contents	1
Congratulations	2
Important safety information	3
Developing your fitness program	4
Aircycle setup and assembly	9
Operating the aircycle	12
A typical exercise session	14
Maintaining your aircycle	15
Specifications	18
Parts list	19
Parts assembly diagram	21

DISCLAIMER

The information presented in this manual is given in good faith and is to the best of our knowledge accurate. However, everyone who uses this information in any way does so entirely at their own risk. Neither Tunturi, Inc., nor their representatives can accept any responsibility for any damage or injury incurred as a result of information presented here except under the terms of warranty of Tunturi products.

IMPORTANT SAFETY INFORMATION

The Tunturi Aircycle is built for optimum safety. However, certain precautions apply whenever you operate a piece of exercise equipment. Be sure to read the entire manual before you assemble or operate the cycle. In particular, note the following safety procedures:

- Consult a physician for a complete examination before beginning any exercise program.
- If you experience dizziness, nausea, chest pains, or other abnormal symptoms, stop your workout at once. Consult a physician before continuing.
- Never operate the cycle near children or pets.
- At the beginning of your workout, allow your body to warm up gradually. Remember to cool down gradually after your workout and to let your pulse rate return to normal.
- Always wear proper clothing and shoes when exercising on the cycle.
- Gentle stretching before and after your exercise session will help prevent stiffness or soreness.
- Only *one* person at a time should use the cycle.
- Use the handlebar when getting on or off the cycle.
- Keep hands away from all moving parts.
- Place the cycle on a solid, level surface when in use.

DEVELOPING YOUR FITNESS PROGRAM

Regardless of your age or current physical condition, you can benefit from a regular exercise program. Physical fitness through exercise equips you to meet the physical, mental, and social demands of everyday life. Through exercise, you will sleep better, eat better, look better, and generally feel better.

CAUTION: It is extremely important to discuss your exercise plans with your physician so that you develop a program appropriate for you.

Here are just some of the benefits of a regular exercise program:

- Improve the condition of your heart and lungs.
- Protect yourself against coronary heart disease.
- Keep weight in check.
- Maintain or develop muscular strength.
- Maintain the health of your bones and your body in general.
- Increase your immunity to infections.
- Increase your alertness and self-confidence.
- Reduce the effects of stress and aging.

THE TWO TYPES OF EXERCISE

There are basically two types of exercises: aerobic and anaerobic. During *anaerobic exercise*, the production of energy does not require oxygen; the body draws fuel from stored compounds in the muscles and from blood sugar (glucose) rather than from fat. Most anaerobic exercises are intense and brief: for example, sprinting, jumping, and weight lifting.

During *aerobic exercise*, energy is produced almost completely with the use of oxygen and the body draws fuel primarily from fat. Muscles require oxygen in order to function; exercise substantially increases your muscles' need for oxygen. In response, your heart pumps faster to provide oxygen-rich blood for the muscles. Some examples of aerobic exercise are cycling, jogging, running, swimming, rowing, cross-country skiing, and stair climbing.

Here are descriptions of the two major health benefits of aerobic exercise:

An efficient cardiovascular system: Regular aerobic exercise makes your cardiovascular (heart-blood vessel) system more efficient. A well-conditioned heart pumps more blood per heart beat; it doesn't have to work as hard to transport oxygen and blood sugar to your muscles. Your resting pulse rate reflects your fitness level; it decreases as your fitness improves.

Efficient fat burning: Aerobic exercise also makes your body burn fat more efficiently. Fat first develops in the muscles. As you age, unexercised muscles slowly become saturated with fat. Eventually, the fat accumulates outside the muscles; this is the fat you can see. When a muscle turns to fat, the size of the muscle decreases. This reduced muscle size tells your body that you need fewer calories. However, research has shown that regular aerobic exercise not only reverses the muscle-to-fat process; it actually increases the body's lean muscle mass. And because muscles require more energy, your body's metabolism automatically increases. You burn more calories *even when you're not exercising*.

TAILORING YOUR OWN AEROBIC EXERCISE PROGRAM

Your fitness program will vary with your age and level of fitness, as well as with your personal exercise preferences. Before beginning any program, you need to ask yourself:

- What sort of exercise do you want to do? You need to make a choice that fits with your lifestyle and personal preferences.
- How long will your exercise sessions be? You need a minimum of 15 minutes to achieve an adequate training level.
- How hard will you exercise? You eventually want to achieve a minimum of 70% maximum heart rate. (This is explained further below.)
- How often can you exercise? You need to exercise at least 3 times per week to get the benefits of a program.

For an exercise program to work, it has to become a part of your lifestyle. Aerobic exercise can burn fat and can strengthen your cardiovascular system. However, its benefits will be temporary if you don't maintain it at least three times each and every week. Your body stores the effects of aerobic exercise for only a short period of time. The chart below describes the relationship of the number of training sessions to the level of fitness.

Number of sessions per week	Level of fitness
2 (or less)	Decreases
3-4	Is maintained
5-6	Improves

So it's very important to develop an exercise program you can live with.

Some people find it easier to maintain a fitness program if they are able to vary their exercise activity from day to day, or season to season; this is called *cross-training*. For example, you might want to run two days and cycle the other two days each week. Or you might want to use a ski machine during the winter and an exercise cycle during the summer. In addition to alleviating boredom, varying your exercise activities also lets you develop different muscle groups, rather than overdeveloping a few muscles.

The next two sections explain specifically how to determine your training zone and how to know when you need to change your training level.

FINDING YOUR AEROBIC TRAINING ZONE

True aerobic exercise means steady, continuous exercise for a period of at least 15 minutes at a level that elevates your heart rate between 70% and 85% of its maximum. This range is referred to as your *aerobic training zone*. Use the chart below to determine the appropriate training zone for your age group.

You won't be able to improve your fitness more quickly by working harder. In fact, if you exercise so hard that your heart rate exceeds your training zone, you will be working anaerobically. To improve your cardiovascular system and burn fat more quickly, you should exercise longer, but always within your aerobic training zone.

To find the exercise level necessary to reach your aerobic training zone you need to monitor your pulse rate during exercise. An electronic pulse monitor can do this. Or you can use the 6-second manual method. To follow the manual method, get a watch or clock that has a second hand and follow these steps:

1. Using your fingers (rather than your thumb), feel your pulse at the thumb-side of the wrist or at the side of the neck.
2. Count your pulse beats for exactly six seconds.
3. Multiply your pulse beats by 10 to find your pulse rate per minute.

If you don't have a pulse monitor, stop and use this manual method a couple of times during your exercise session. If you are not within the correct aerobic training zone for your age group, increase or decrease your speed and/or resistance level accordingly until your heart rate falls within your target range.

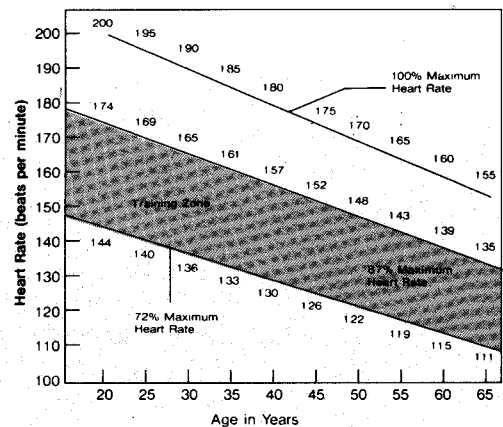

EXERCISE INTENSITY

The intensity necessary to reach the training zone varies greatly from individual to individual. For example, one person at age fifty may require only a moderate walk to reach the appropriate training zone, while another person of the same age might have to maintain a fast jog. You may need to begin your exercise program at 50% to 60% of maximum heart rate and work up to a level of 70% to 85%.

As you grow older, your maximum heart rate lowers, and thus your aerobic training zone lowers too. This is true of everybody, regardless of physical condition. So don't expect to always exercise at the same intensity.

WARMING UP AND COOLING DOWN

Even the well-conditioned athlete's muscles are generally cold and stiff before exercise. Muscles in such a condition are vulnerable to injury; for this reason it's essential to warm up before any exercise session—even before stretching. Warming up also helps stimulate your heart and lungs. Your blood vessels dilate, increasing the necessary blood flow to the muscles.

For aerobic exercises, you can simply do a slower version of the exercise you intend to do. For example, cycle at a lower intensity, or walk or jog at a slower speed for several minutes before beginning your aerobic session.

After your exercise session, gradually taper off from your exercise intensity and keep moving for several minutes. Stopping abruptly can allow blood to pool in the arms and legs; if you keep moving, the blood flow is directed back to the heart and brain.

To complete the cool-down process, do some all-body stretching exercises to relax the worked muscles. This post-exercise stretching session helps prevent your muscles from being stiff and sore during the next day's workout. Also it's easier to stretch muscles after exercising when they're still warm and supple.



Knee Swing



Side Lunge

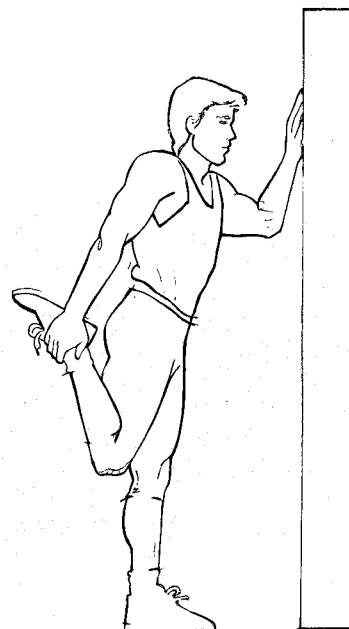

Standing
Quad Stretch

STRETCHING

Stretching exercises improve flexibility, the range of motion around a joint. Some research has shown that muscles actually grow shorter as we age if they are deprived of exercise. Stretching helps alleviate this trend and keeps muscles young and supple. And as discussed above, stretching helps prevent stiffness and soreness after exercise. Pay special attention to stretching any muscles that have given you difficulty in the past.

Always use *static* stretches. These are slow, smooth stretches that create a steady (but not painful) pulling sensation in the muscle. The other type of stretching, *ballistic stretching*, involves bouncing into the stretch; it is not recommended because it can lead to torn and damaged muscles.

Below are some stretches you can use before and after your exercise session. Be sure to perform any stretching exercise *slowly and smoothly*. Ease into the stretch. Once you feel some resistance, hold your position for several seconds. Do not hold a stretch beyond what is comfortable.

EXERCISING WITH YOUR TUNTURI AIRCYCLE

Cycling is an excellent form of aerobic exercise; it improves the mobility of the joints without the risk of injury associated with impact exercises.

The Tunturi Aircycle provides a complete upper and lower body workout for aerobic, muscular and cardiovascular benefits. You can work the handlebars independently from the pedals, or simultaneously while cycling.

Adjust the speed and/or tension on the Aircycle to reach your aerobic training zone. The Tunturi Electronics Module monitors your speed, time, distance, and approximate calories consumed.

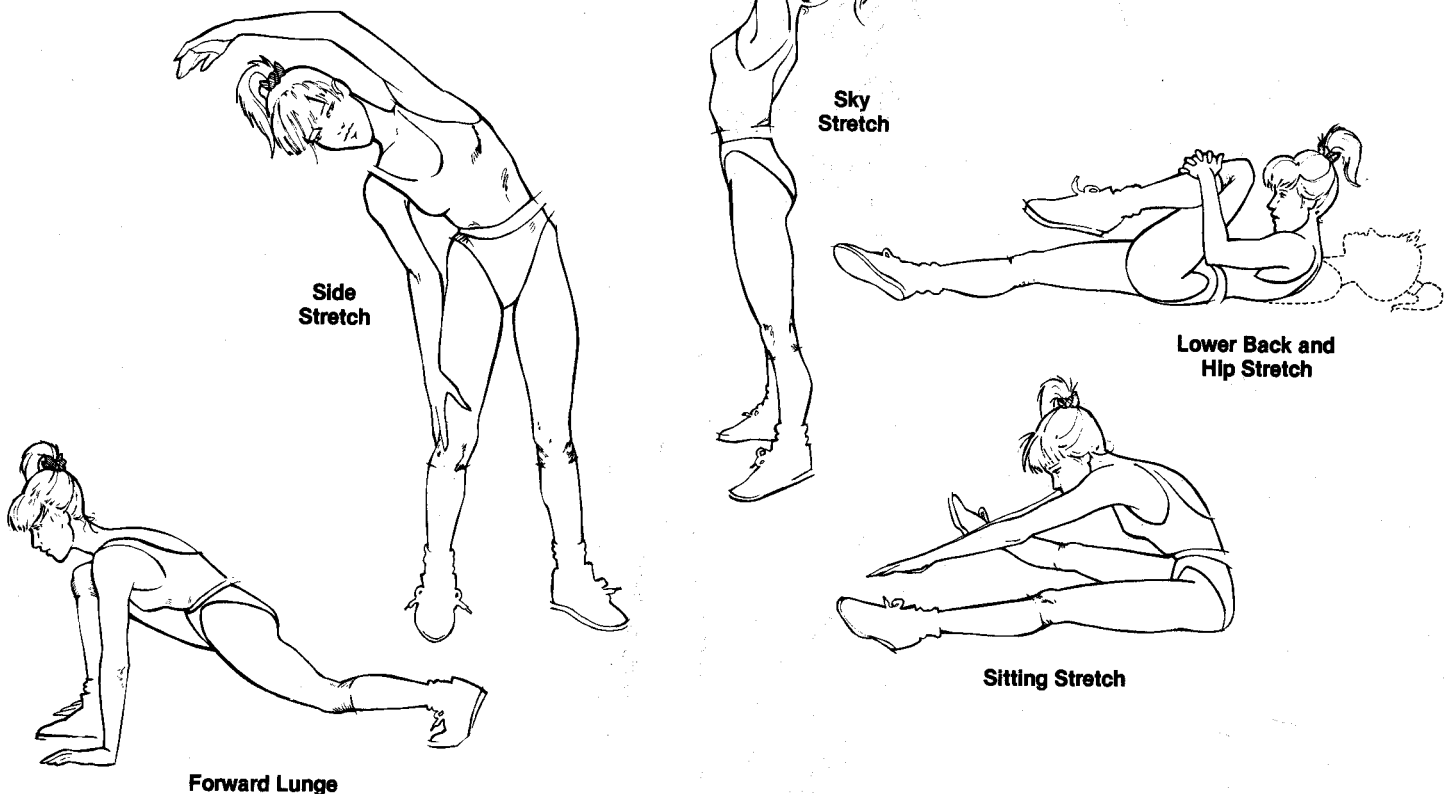

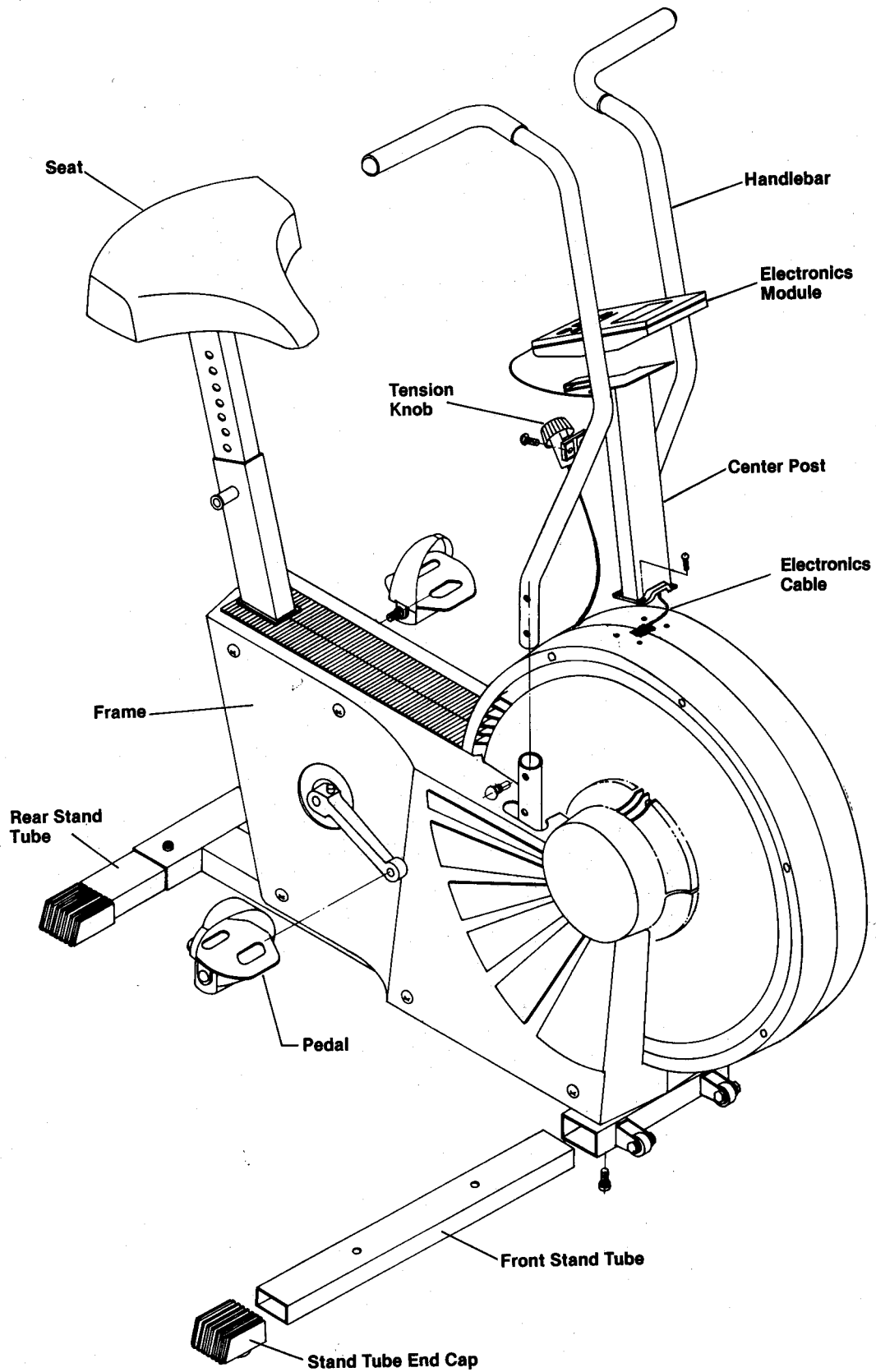

AIRCYCLE SETUP AND ASSEMBLY

Your Tunturi Aircycle is shipped with the parts and tools required for assembly.

UNPACKING

Take the parts of the cycle out of the box and set them on the floor. To identify the parts refer to the exploded diagram. Make sure that you have all the following items:

- Cycle assembly parts
 - Frame
 - Center post
 - Front stand tube
 - Rear stand tube
 - Four stand tube end caps
 - Two pedals
 - Electronics module (batteries included)
 - Seat
 - Two handlebars
- Tools
 - Hex key wrench, 5mm
 - Combination wrench, 8mm x 12mm x 15mm
- Fasteners and other hardware
 - 4 button-head, hex-drive bolts (5/16" x 1/2")
 - 6 screws (M5 x 5/8")
 - 4 hex-drive bolts (5/16" x 1 1/4")

ASSEMBLY

In these instructions, assume that you are sitting on the cycle to determine the direction of front, back, right, and left.

1. Attach the rear stand tube to the frame.
 - a. Insert the rear stand tube through one end of the opening at the base of the frame (see illustration #1).
 - b. Gently push the rear stand tube through the opening until the bolt holes on the frame match the bolt holes on the rear stand tube.
 - c. Use the hex key wrench to secure the stand tube with 2 button-head hex-drive bolts (5/16 x 1/2).
 - d. Attach the two stand-tube end caps.
2. Attach the front stand tube to the frame.
 - a. Rotate the front of the cycle upward so that the seat post rests on the floor.
 - b. Attach the front stand tube to the frame using the instructions found in step 1.

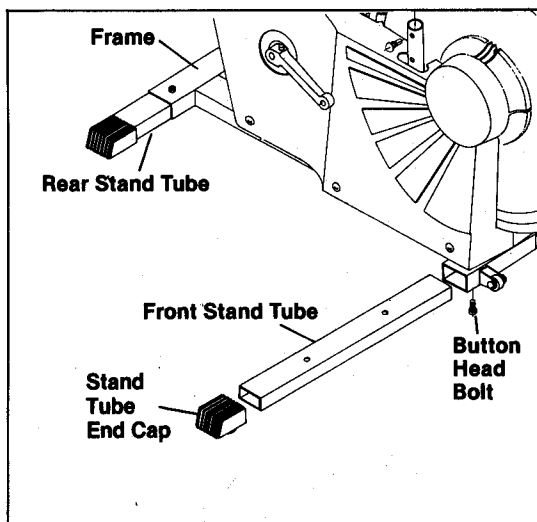

3. Attach the center post to the frame.

- a. Thread the electronic cable extending from the top of the fan cage through the center post (see illustration #2).

Hold the center post upside down (alongside the cycle frame) and thread the electronics cable down from the bottom of the center post and through the access hole at the top of the center post.

- b. Seat the center post over the fan cage. Make sure it is properly aligned.

- c. Insert 4 screws (M5 x 5/8") into the corner holes in the base of the center post.

CAUTION: Be careful not to pinch the cable during this operation.

- d. Secure the screws with a Phillips screwdriver.

4. Attach the tension knob.

- a. Secure the tension knob to the center post using two screws (M5 x 5/8") (see illustration #2).

- b. Position the tension cable in the retaining clip on the center post.

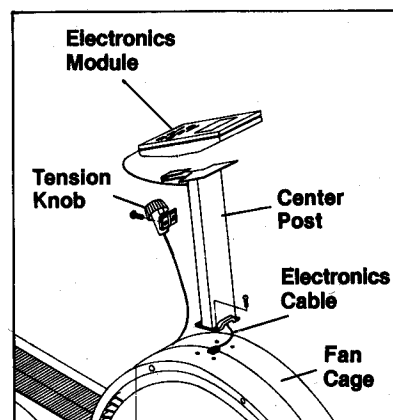

5. Attach the handlebars.

- a. Insert the right handlebar into the tube on the right side of the frame (see illustration #3).
- b. Use the hex wrench to secure the handlebar with two button-head bolts (5/16" x 1 1/4") and two star washers.
- c. Repeat these steps for the left handlebar.

6. Attach the pedals.

- a. Gently press the right pedal onto the right crank. (See illustration #4.)

NOTE: Each foot pedal is identified with an "R" or an "L".

- b. Using the 15mm combination wrench, tighten the screw attached to the base of the pedal clockwise.
- c. Repeat these steps for the left pedal. Turn counterclockwise to tighten.

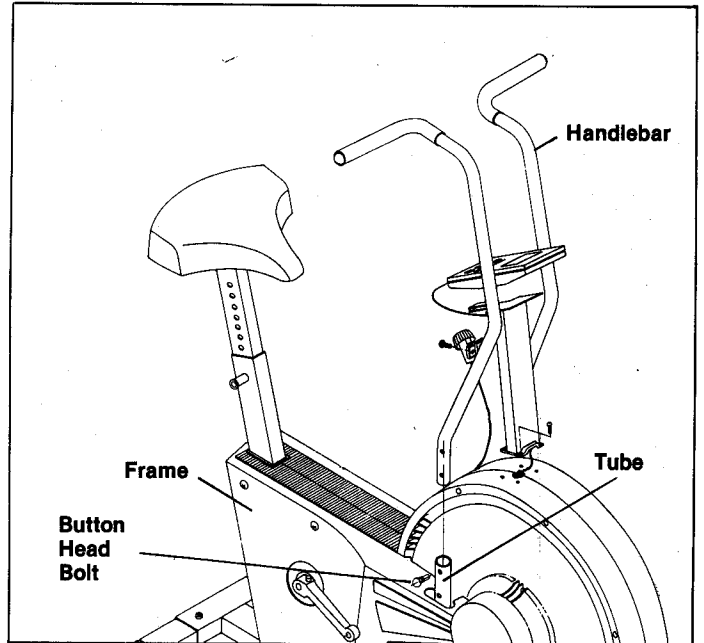

3

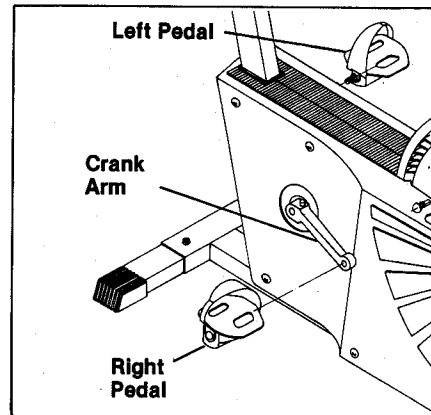

4

7. Attach the seat post.

- a. Insert the seat post into the frame.
- b. The seat post has 15 height-adjustment holes set 1" apart. To adjust the height of the seat, pull out and hold the spring-loaded locking pin on the frame.
- c. Align the desired height adjustment hole with the locking pin.
- d. Slowly release the locking pin. The locking pin should fit securely into the height adjustment hole. (See illustration #5.)

8. Attach the electronics module.

- a. Unpack the electronics module from the separate packing box.
- b. Open the battery compartment door and insert 2 AA batteries into the back of the module. The correct direction of the batteries appears on the inside of the battery compartment.

c. Slide the computer onto its bracket on the center post.

d. Attach the connector on the cable to the matching connector at the back of the module.

e. Carefully push the remaining length of electronics cable into the center post. (See illustration #2.)

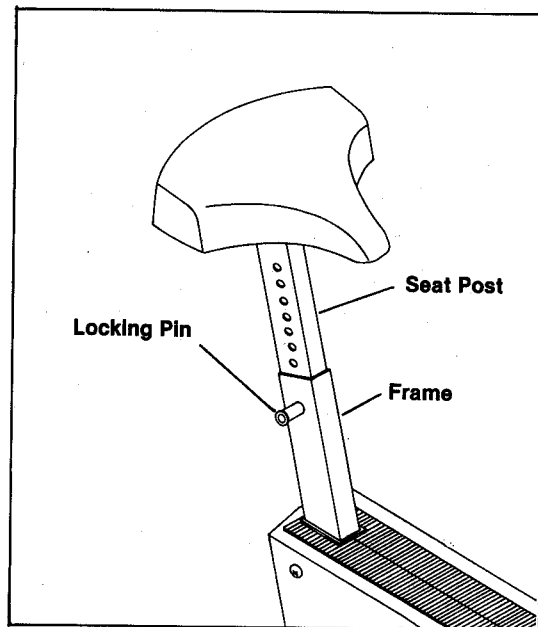

5

OPERATING THE AIRCYCLE

The Tunturi Professional Air-cycle lets you create an exercise program that meets your specific needs. You can determine the time, speed, distance, and RPMs that you cycle, and you can monitor your calorie expenditure for each workout.

You should be familiar with the electronics module and its features before you begin exercising. Here is a list explaining the use of the keys and the display window.

KEY FUNCTIONS

START/STOP: Use this key to turn the module on. The module shuts off automatically after three minutes if it is not being used.

Press this key to enter start mode and begin tracking the speed, time, distance, RPMs, and calories during your exercise session. If you press START/STOP again, the module will enter stop mode and the value of the selected mode remains and the other mode values are retained in memory until the electronics module turns off or you press RESET. The word STOP appears in the display when you stop the electronics module.

SET ▲, SET ▼: Press these keys to preset your exercise time or distance. Before choosing this option, turn the electronics module on and make sure STOP appears in the display.

These keys are discussed in more detail in the next section.

To reset the values for TIME, DISTANCE, or CALORIES to zero, press the SET ▲ and SET ▼ keys simultaneously when the value you want to reset is displayed in the window.

MODE: Use this key to step through the five modes in the display window. Pressing MODE moves the arrow in the display one position to the right. Modes are always selected in sequence.

TIME: Tracks the elapsed time of each exercise session from 0 to 99 minutes. If you preset your workout time, the electronics module begins to count down. The remaining time appears in the display.

SPEED: Calculates miles per hour (mile/h) from 0 to 99.99.

DISTANCE: Tracks the elapsed distance traveled during the exercise session from 0 to 99.99 miles. If you preset your workout distance, the electronics module begins to count down. The remaining distance appears in the display.

RPM: CALCULATES revolutions from 0 to 700 RPMs. The RPM bar graph also shows the revolutions per minute (RPM x 100) from 0 to 700 RPMs. The RPM bar graph is always displayed regardless of other modes you may have selected.

CALORIES: The module calculates the approximate calories consumed during your exercise session.

SCAN: To enter SCAN mode, press MODE until the arrow points to TIME. The speed, time, distance, RPMs, and calories modes are displayed at 5-second intervals throughout your workout session. The word SCAN appears in the display. Press MODE to leave SCAN mode. The word SCAN disappears from the screen.

SETTING THE ELECTRONICS MODULE FOR YOUR PERSONAL GOALS:

To preset your exercise time:

1. Make sure STOP appears in the display. Then press MODE until the arrow in the display points to TIME. If the word SCAN appears in the display, press MODE again.
2. Press SET ▲ to advance the preset time one minute. Hold down SET ▲ to advance quickly to the desired time (from 0 to 99 minutes). A bell symbol appears in the display to indicate that the count-down timer is set.
3. If you advance the preset timer farther than desired, press the SET ▼ key to decrease the preset time by 1 minute.

4. Press START/STOP. The electronics module begins to count down in seconds. The time remaining is displayed. A tone sounds when the present time reaches zero (0.00).

If you do not preset your exercise time, the elapsed time is displayed and the bell symbol does not appear.

To preset your exercise distance:

1. Make sure STOP appears in the display. Then press MODE until the arrow in the display points to the distance. If the word SCAN appears in the display, press MODE again.

2. Press SET ▲ to advance the preset distance by 1/10 of a mile. Hold down SET ▲ to advance quickly to the desired distance (.10 to 99.00). A ((·)) symbol appears in the display to indicate that the count-down distance is set.

3. If you advance the preset distance farther than desired, press the SET ▼ key to decrease the preset distance by 1/10 of a mile.

4. Press START/STOP. The electronics module begins to count down in 1/10 mile increments. The distance remaining is displayed. A tone sounds when the preset distance reaches zero (0.00).

If you do not preset your exercise distance, the elapsed distance is displayed and the ((·)) symbol does not appear.

A TYPICAL EXERCISE SESSION

Here's a step-by-step example of how you might program the computer and prepare your cycle for your exercise session:

1. Adjust the height of the seat post.

The seat height should allow the knee to be slightly bent (not completely straight) when your leg is extended while pedaling.

- a. Pull the spring-loaded adjustment pin.
- b. Lift the adjustment pin and choose one of the adjustment holes in the seat post.
- c. Release the locking pin. Make sure the pin is secure in the hole before sitting on the seat.

NOTE: Do not pull out the adjustment pin while you're sitting on the seat.

2. Adjust the pedal straps.

You need to adjust the pedal straps so that it's easy to slip your feet in and out of the pedals.

- a. Place one foot in each of the pedals and adjust the pedal straps to the desired tightness.
- b. Fit the pedal strap over the selected securing tab on the pedal.
- c. Pull down firmly on the pedal strap.

To release the pedal strap, pull up and out on the strap. The strap should snap easily over the securing tab.

3. Set up the electronics module for your exercise goals.

- a. To turn the module on, press START/STOP.

- b. Press MODE until the arrow in the display points to TIME.

To set the time you want to cycle (from 0 to 99 minutes), press SET ▲ until the time you want appears in the display.

- c. Press MODE until the arrow in the display points to DISTANCE.

To set the distance you want to cycle (from .10 to .99 miles) press SET ▲.

- d. Press STOP/START. When you press this key, the module begins to track speed, time, distance, RPMs, and calories. A tone sounds when the preset time and distance reach zero.

- e. Press MODE until you reach TIME to scan speed, time, distance, RPMs, and calories in sequence in the display.

4. Adjust the resistance.

- a. Press down on the pedal with your right foot, and push one of the handlebars forward. Continue to alternate this push and pull motion with the handlebars as you cycle. You can control the resistance by adjusting the speed or tension control knob.

- b. Turn the tension control knob clockwise to increase the resistance and counterclockwise to decrease the resistance.

5. End your session.

At the end of each exercise session, slow your cycling and arm action to bring your heart rate down to normal.

MAINTAINING YOUR AIRCYCLE

The Tunturi Professional Air-cycle requires very little maintenance. Be sure to clean your cycle with a damp cloth or towel after each workout.

If you have any problems while performing maintenance on your cycle, consult an authorized service representative.

LUBRICATING THE CHAINS

To ensure that your cycle will continue to operate correctly, you need to oil the chain once a year.

1. Remove the left pedal crank assembly.
 - a. Use a 10 mm open-end wrench to turn the bolt at the base of the crank clockwise to loosen.
 - b. Remove the cotter pin and pull off the crank. It may be necessary to gently pound the bolt-end of the cotter pin to slide it out.
2. Remove the left side cover from the front frame.
 - a. Use a Phillips-head screwdriver to remove the six Phillips-head screws.
 - b. Remove the left cover.
3. Lubricate the chain.

Use a few drops of household lubricant or aerosol spray and wipe off any excess oil.
4. Turn the pedal to advance the chain until the entire chain is lubricated.
5. Reassemble the left cover, and left pedal crank assembly.

ADJUSTING OR REPLACING THE TENSION BELT

1. Make sure the resistance adjustment is turned to the full minus position.
2. Remove the right pedal crank assembly.
 - a. Use a 10mm open-end wrench to turn the bolt at the base of the crank counter-clockwise to loosen.
 - b. Remove the cotter pin and pull off the crank. It may be necessary to gently pound the bolt-end of the cotter pin to slide it out.
3. Remove the right cover from the frame.
 - a. Use a Phillips-head screwdriver to remove the six Phillips-head screws.
 - b. Remove the right cover.

4. Remove the right hub cover.
 - a. Gently snap the hub cover out of the fan housing by pressing on the sides.
5. Release the belt from the cam clip.
 - a. To release the cam clip, it may be necessary to use a screwdriver to pop the clip open.

You need to replace the tension belt if the "felt" side of the belt is worn down to the nylon webbing.

If you are not replacing the tension belt, skip step 6.

6. Replace the tension belt.
 - a. Pull the tension belt from around the fan hub, toward the tension spring.
 - b. Disconnect the spring from the end of the tension belt.
 - c. Connect the new tension belt to the spring.
 - d. Carefully thread the new tension belt around the fan hub. Make sure the belt does not twist and that the "felt" side of the belt is facing the metal hub.
 - e. Thread the belt through the cam clip.

SPECIFICATIONS

DIMENSIONS AND MATERIAL

Length	45.25"
Height	51"
Width	21"
Adjustment range of seat	12"
Weight	81 lbs.
Frame Material	Steel

FUNCTIONS

Time range	0 to 99 minutes (count up) 99 to 0 minutes (count down)
Speed range	0 to 99.99 miles per hour
Distance range	0 to 99.99 miles (count up) 99.99 to 0 miles (count down)
RPMs	0 to 700 revolutions per minute
Calories	1 to 9990
Batteries	(2) two 1.5v AA

PARTS LIST

REFERENCE NUMBER	DESCRIPTION	QTY./UNIT
1	FRAME-PAINTED	1
2	TUNTURI LABEL	1
3	MODEL LABEL	1 set
40	PEDAL AXLE ASSEMBLY	1
41	AXLE BUSHING	2
42	CRANK ARM LEFT	1
43	CRANK ARM RIGHT	1
44	TENSION ARM	1
45	SPRING	1
46	COLLAR	1
47	DRIVE AXLE ASSEMBLY	1
48	SPROCKET	1
49	CRANK ARM	1
54	ROLLER	2
55	WASHER	2
56	LOWER ARM L&R	1 set
59	BUSHING	2
60	UPPER ARMS L&R	1 set
62	WASHER	3
63	AXLE ASSEMBLY	1
64	BEARING HOUSING	2
65	TENSION PLATE	2
66	WASHER	4
67	FAN WHEEL	1
68	TENSION DRUM	1
69	TENSION STRAP	1
70	WHEEL COVER L&R	1 set
71	BOLT	6
72	HUB COVER L&R	1 set
73	SIDE COVER L&R	1 set
74	CENTER POST	1
78	STAND TUBE	2
79	SLEEVE	4
80	END CAP	4
81	SEAT POST	1
82	BUSHING	1
83	PLUNGER PIN ASSEMBLY	1
87	WHEEL	2
88	BOLT	2
89	CABLE AND SENSOR	1
90	BOLT	4
91	STAR WASHER	4
101	PEDAL	1 set
102	STRAP	1 set
103	LARGE CHAIN	1
104	SMALL CHAIN	1

REFERENCE NUMBER	DESCRIPTION	QTY./UNIT
105	SPROCKET	1
106	NUT	1
107	IDLER SPROCKET	1
109	ELECTRONICS MODULE	1
110	SEAT	1
111	FOAM GRIP	2
112	END CAP	2
113	STRAP CLAMP	1
115	TENSION CONTROLLER & SCREWS	1
152	SNAP RING	5
153	SNAP RING	3
154	KEY	1
155	BOLT	2
156	NUT	4
157	BOLT	4
158	BOLT	6
159	SCREW	1
160	NUT	8
161	WASHER	4
162	WASHER	2
163	BOLT	1
164	BOLT	1
166	SCREW	8
167	SCREW	2
168	BOLT	4
169	NUT CLIP	10
170	SCREW	10
174	BOLT	4
176	BOLT	1

