

Agilent 85225F **Performance Modeling System**

Installation and User's Guide

Notices

© Agilent Technologies, Inc. 2005

No part of this manual may be reproduced in any form or by any means (including electronic storage and retrieval or translation into a foreign language) without prior agreement and written consent from Agilent Technologies, Inc. as governed by United States and international copyright laws.

Acknowledgments

UNIX® is a registered trademark of the Open Group.

Windows NT® is a U.S. registered trademark of Microsoft Corporation.

Windows® and MS Windows are U.S. registered trademarks of Microsoft Corporation.

Manual Part Number

85225-90023

Edition

First edition, April 2005

Printed in USA

Agilent Technologies, Inc.
1400 Fountaingrove Parkway
Santa Rosa, CA 95403 USA

Warranty

The material contained in this document is provided “as is,” and is subject to being changed, without notice, in future editions. Further, to the maximum extent permitted by applicable law, Agilent disclaims all warranties, either express or implied, with regard to this manual and any information contained herein, including but not limited to the implied warranties of merchantability and fitness for a particular purpose. Agilent shall not be liable for errors or for incidental or consequential damages in connection with the furnishing, use, or performance of this document or of any information contained herein. Should Agilent and the user have a separate written agreement with warranty terms covering the material in this document that conflict with these terms, the warranty terms in the separate agreement shall control.

Technology Licenses

The hardware and/or software described in this document are furnished under a license and may be used or copied only in accordance with the terms of such license.

Restricted Rights Legend

If software is for use in the performance of a U.S. Government prime contract or sub-contract, Software is delivered and licensed as “Commercial computer software” as defined in DFAR 252.227-7014 (June 1995), or as a “commercial item” as defined in FAR 2.101(a) or as “Restricted computer software” as defined in FAR 52.227-19 (June 1987) or any equivalent

agency regulation or contract clause. Use, duplication or disclosure of Software is subject to Agilent Technologies’ standard commercial license terms, and non-DOD Departments and Agencies of the U.S. Government will receive no greater than Restricted Rights as defined in FAR 52.227-19(c)(1-2) (June 1987). U.S. Government users will receive no greater than Limited Rights as defined in FAR 52.227-14 (June 1987) or DFAR 252.227-7015 (b)(2) (November 1995), as applicable in any technical data.

Safety and Regulatory Information

Warnings, Cautions, and Notes

This installation and user's guide utilizes the following safety notations. Familiarize yourself with each notation and its meaning before operating the Agilent 85225F performance modeling system.

WARNING

A **WARNING** notice denotes a hazard. It calls attention to an operating procedure, practice, or the like that, if not correctly performed or adhered to, could result in personal injury or death. Do not proceed beyond a **WARNING** notice until the indicated conditions are fully understood and met.

CAUTION

A **CAUTION** notice denotes a hazard. It calls attention to an operating procedure, practice, or the like that, if not correctly performed or adhered to, could result in damage to the product or loss of important data. Do not proceed beyond a **CAUTION** notice until the indicated conditions are fully understood and met.

NOTE

A **NOTE** calls the user's attention to an important point or special information within the text. It provides additional information or instructions.

Safety Symbols and Instrument Markings

Symbols and markings in documentation and on instruments alert you to potential risks, provide information about conditions, and comply with international regulations. [Table A](#) defines the safety symbols and [Table B](#) on page 5 defines the instrument markings you may find in the documentation or on an instrument.

Table A Safety Symbols











Symbols	Definition
	Warning: risk of electric shock.
	Warning: hot surface.
	Caution: refer to instrument documentation.
	Laser radiation symbol: marked on products that have a laser output.
	Alternating current.
	Both direct and alternating current.
	Three-phase alternating current.
	Earth (ground) terminal.
	Protective earth (ground) terminal.
	Frame or chassis terminal.
	Terminal is at earth potential. Used for measurement and control circuits designed to be operated with one terminal at earth potential.
N	Terminal for neutral conductor on permanently installed equipment.
L	Terminal for line conductor on permanently installed equipment.

Table A Safety Symbols (continued)









Symbols	Definition
	Standby (supply). Units with this symbol are not completely disconnected from AC mains when this switch is in the standby position. To completely disconnect the unit from AC mains, either disconnect the power cord, or have a qualified/licensed electrician install an external switch.
	ON (supply). A switch with this symbol closes the instrument's power supply circuit, connecting it to the mains supply.
	OFF (supply). A switch with this symbol opens the instrument's power supply circuit, disconnecting it from the mains supply.

Table B Instrument Markings

Marking	Definition
	The instruction documentation symbol appears when it is necessary for the user to refer to the instruction in the documentation.
	The CE mark is a registered trademark of the European Community.
	This product complies with the WEEE Directive (2002/96/EC) marking requirements. The affixed label indicates that you must not discard this electrical/electronic product in domestic household waste. To return unwanted products, contact your local Agilent Technologies office, or see www.agilent.com for more information.
	The CSA mark is a registered trademark of the CSA-International.
 N10149	The C-tick mark is a registered trademark of the Spectrum Management Agency of Australia. This signifies compliance with the Australian EMC Framework regulations under the terms of the Radio Communications Act of 1992.
ISM1-A	This text indicates that the instrument is an Industrial Scientific and Medical Group 1 Class A product (CISPER 11, Clause 4).
ICES/NMB-001	This text indicates product compliance with the Canadian Interference-Causing Equipment Standard (ICES-001).

Operator Safety Requirements

The following general safety precautions must be observed during all phases of operation of this system. Failure to comply with these precautions or with specific warnings elsewhere in this manual violates

safety standards of design, manufacture, and intended use of the product. Agilent Technologies, Inc. assumes no liability for the customer's failure to comply with these requirements.

For additional safety precautions, including precautions for making device measurements in a floating ground configuration, see ["To ensure your safety while using the system"](#) on page 76.

WARNING

This is a Safety Class 1 Product (provided with a protective earthing ground incorporated in the mains supply cord). The mains plug shall be inserted only in a socket outlet provided with a protective earth contact. Any interruption of the protective conductor inside or outside of the product is likely to make the product dangerous. Intentional interruption is prohibited.

WARNING

If this product is not used as specified, the protection provided by the equipment could be impaired. This product must be used only in a normal condition (in which all means for protection are intact) only.

WARNING

DO NOT OPERATE IN AN EXPLOSIVE ATMOSPHERE. Do not operate the instrument in the presence of flammable gases or flames.

WARNING

DO NOT REMOVE THE INSTRUMENT COVER. Operating personnel must not remove instrument covers. Component replacement and internal adjustments must be made only by qualified service personnel. Instruments that appear damaged or defective should be made inoperative and secured against unintended operation until they can be repaired by qualified service personnel.

WARNING

Installing additional instruments may destabilize the rack cabinet.

WARNING

Installing additional instruments into the cabinet electrical system could produce excessive leakage current. If the protective earth conductor is interrupted or faulted, the user risks serious injury or death.

WARNING

Prior to adding any additional instruments, review all wiring and cooling capabilities to verify adequate design margins for normal and under single fault conditions.

Mains power

CAUTION

The mains cable shall be permanently connected to the premise circuit breaker or connected using an agency approved twist-lock connector.

Ground the system

WARNING

To minimize shock hazard, the rack cabinet must be connected to an electrical protective earth ground. The power distribution unit (PDU) must be connected to the AC power mains through a grounded power cable, with the ground wire firmly connected to an electrical ground (safety ground) at the power outlet.

WARNING

Any interruption of the protective (grounding) conductor or disconnection of the protective earth terminal will cause a potential shock hazard that could result in personal injury.

Before applying power

CAUTION

Verify that the product is set to match the available line voltage, the correct fuse is installed, and all safety precautions are taken. Before applying power, note the product's external markings described in [Table A, "Safety Symbols,"](#) on page 4 and [Table B, "Instrument Markings,"](#) on page 5.

CAUTION

It is recommended that the premise wiring contain an adequate circuit breaker for system protection.

CAUTION

To remove power from the cabinet, remove the mains supply from the premise electrical supply.

CAUTION

Before switching on this system, make sure that the supply voltage is in the specified range.

CAUTION

The front panel LINE switch disconnects the mains circuit from the mains supply. However, the mains supply to the power distribution unit remains energized.

Fuses and breakers

WARNING

For continued protection against fire hazard, use only fuses with the required rated current, voltage, and specified type (normal blow, time delay). Do not use repaired fuses or short-circuited fuse holders. Replace only with an identical fuse.

There are two resettable thermal breakers located on the power strips. These are in the “hot” and “neutral” lines.

Before cleaning the system

WARNING

To prevent electrical shock, disconnect the system from mains before cleaning. Use a dry (or slightly water-dampened) cloth to clean external case parts. Do not attempt to clean internally.

Overcurrent protection

CAUTION

If the power outlet strip breaker trips once, reset the breaker. If the breaker trips twice, call a qualified/licensed electrician to service the test system.

Statement of Compliance and Declaration of Conformity

This product has been designed and tested in accordance with accepted industry standards, and has been supplied in a safe condition. The documentation contains information and warnings that must be followed by the user to ensure safe operation and to maintain the product in a safe condition.

The Manufacturer’s Declaration of Conformity is available upon request.

Statement of CAN/CSA Compliance

This product has been designed and tested in accordance with CAN/CSA-C22.2 No. 61010-1 IEC.

Compliance with German Noise Requirements

This is to declare that this instrument is in conformance with the German Regulation on Noise Declaration for Machines (Laermangabe nach der Maschinenlaermrerordnung -3.GSGV Deutschland).

Acoustic Noise Emission/Geraeuschemission	
LpA <70 dB	LpA <70 dB
Operator position	am Arbeitsplatz
Normal position	normaler Betrieb
per ISO 7779	nach DIN 45635 t.19

Compliance with Canadian EMC Requirements

This ISM device complies with Canadian ICES-001. Cet appareil ISM est conformé à la norme NMB du Canada.

IEC/EN 61000-4-2 Electrostatic Discharge Immunity Test

This system passes using criterion C where operator intervention may be necessary to restart the measurement software operations.

IEC/EN 61326 Electrostatic Discharge and Surge Immunity Test

This system complies with the Electrostatic Discharge and Surge Immunity requirements in the IEC/EN 61326 standard using Performance Criterion C.

For Technical Assistance

To receive technical assistance, visit the online assistance web site, or call the telephone number listed in [Table 19](#) on page 107 appropriate to the location of modeling system.

In This Guide...

This guide provides instruction on installing, verifying, and servicing the system, as well as an introductory system overview and reference material. This information is presented for use by the customer or an Agilent Technologies field engineer.

1 Introducing the Agilent 85225F Performance Modeling System

This chapter provides a description of the system, its components, integration, and characteristics.

2 Installing the System

Here you will find instruction on preparing the installation site, receiving and inspecting the system (including a receiving checklist), installing the worksurface, ensuring operator safety, connecting the bias networks, and powering-on the system.

3 Verifying System Functionality

Turn here for instruction on choosing a level of system verification and performing a post-installation functional verification test using a system controller running IC-CAP software.

4 Servicing the System

This chapter includes instruction on troubleshooting the system, removing and replacing system components, ordering replacement parts, and acquiring additional assistance in solving measurement problems.

A Enhancing Measurement Accuracy

See this appendix for instruction on cleaning the system connections, performing a system measurement calibration, and suggested intervals for periodic component calibration.

B DC Subsystem Functional Verification Tests

Turn here to find Agilent 4156C precision semiconductor parameter analyzer and Agilent E5260A/70B high speed/precision parameteric measurement mainframe functional verification tests that *do not require* the IC-CAP software.

C RF Subsystem Functional Verification Tests

This appendix includes an Agilent E8364B PNA Series vector network analyzer functional verification test that *does not require* the IC-CAP software.

D CV Subsystem Functional Verification Tests

This appendix includes an Agilent 4284A precision LCR meter functional verification test that *does not require* the IC-CAP software.

E Noise Subsystem Functional Verification Tests

This appendix includes an Agilent 35670A dynamic signal analyzer functional verification test that *does not require* the IC-CAP software.

F Understanding the Bias Networks

Here you will find features, characteristics, a schematic diagram, and operational information on the bias networks.

G Network Analyzer Performance Specification Summary

See this appendix for a summary of the network analyzer's performance specifications.

For Additional Information on...

Hardware

Additional information regarding instruments and accessories within the system is provided in the individual instrument or accessory's documentation.

Software

IC-CAP software operating instructions and tutorials are provided in the Agilent 85190D IC-CAP user's guide.

Typeface Conventions

This guide uses the following typeface conventions to describe various aspects of a particular hardware or software user interface.

Hardware

Interface	Examples in Body Text	Examples in Procedural Text and Tables
Front panel hardkeys	Press <code>Preset</code> Press <code>Cal</code>	Press <code>Preset</code> Press <code>Cal</code>
Front panel display softkeys	Press <code>[MORE]</code> Press <code>[Return]</code>	Press <code>[MORE]</code> Press <code>[Return]</code>
Front or rear panel connectors, instrument markings	<code>RF/DC OUT</code> connector <code>STIMULUS</code> key group	<code>RF/DC OUT</code> connector <code>STIMULUS</code> key group
Data field entries	<code>Enter Calset</code> <code>Enter 18</code>	<code>Enter Calset</code> <code>Enter 18</code>
Keyboard keys	Press <code>Ctrl+8</code> Press <code>Enter</code>	Press <code>Ctrl+8</code> Press <code>Enter</code>

Software

Interface	Examples in Body Text	Examples in Procedural Text and Tables
Screen buttons and selections	Click <code>Enter</code> Select <code>Continuous</code>	Click <code>Enter</code> Select <code>Continuous</code>
Menu selections	Choose <code>Format > Small</code> Choose <code>Cal > Full</code>	Choose <code>Format > Small</code> Choose <code>Cal > Full</code>
Command and menu names	The <code>Save</code> commands are in the <code>File</code> menu.	The <code>Save</code> commands are in the <code>File</code> menu.
Icon and window titles	The <code>Model</code> icons are in the <code>IC-CAP/Main</code> window.	The <code>Model</code> icons are in the <code>IC-CAP/Main</code> window.
Program messages	<code>Is the device connected?</code>	<code>Is the device connected?</code>
Data field entries	<code>Enter Calset</code> <code>Enter 18</code>	<code>Enter Calset</code> <code>Enter 18</code>

Contents

1 Introducing the Agilent 85225F Performance Modeling System

Performance Modeling System Configuration Overview	18
RF and DC Measurement System Configuration	19
Figure 1. System Block Diagram	19
The RF Subsystem	20
The DC Subsystem	20
The Bias Networks	21
Component Integration	22
Figure 2. System Components	23
Table 3. Front Panel System Connections, with Agilent 4156C	24
Figure 3. Front Panel Connections with Agilent 4156C	25
Table 4. Front Panel System Connections, with Agilent E5260A or E5270B	26
Figure 4. Front Panel Wiring Diagram with Agilent E5260A or E5270B	27
Table 5. Rear Panel System Connections with Agilent 4156C	28
Figure 5. Rear Panel Wiring Diagram with Agilent 4156C	29
Table 6. Rear Panel System Connections with Agilent E5260A or E5270B	30
Figure 6. Rear Panel Wiring with Agilent E5260A or E5270B	31
Figure 7. DC/RF Cabling Diagram - DC and RF Configuration	32
CV, RF, and DC Measurement System Configuration	33
Figure 8. System Block Diagram	33
The CV Subsystem	34
Component Integration	34
Figure 9. System Components	35
Table 7. Front Panel System Connections	36
Figure 10. Front Panel Wiring Diagram	37
Table 8. Rear Panel System Connections	38
Figure 11. Rear Panel Wiring Diagram	39
Figure 12. DC/RF Cabling Diagram - DC and RF Configuration	40
Figure 13. DC/RF Cabling Diagram - Parametric Configuration	41
The Low Leakage Switch Mainframe	42
Table 9. Rear Panel Connections, including Low Leakage Switch Mainframe	42
Figure 14. Rear Panel Wiring Diagram including Low Leakage Switch Mainframe	43
Figure 15. DC/RF Cabling Diagram - Parametric Configuration with Low Leakage Switch Mainframe	44

1/f Noise, CV, RF, and DC Measurement System Configuration	45
Figure 16. System Block Diagram	46
Figure 17. 1/f Noise Measurement Block Diagram	47
Component Integration	48
Figure 18. System Components	49
Table 10. Front Panel System Connections	50
Figure 19. Front Panel Wiring Diagram	51
Table 11. Rear Panel System Connections	52
Figure 20. Rear Panel Wiring Diagram	53
Figure 21. DC/RF Cabling Diagram - DC and RF Configuration	54
Figure 22. DC/RF Cabling Diagram - Parametric Configuration	55
Instrument Control Interface	56
Table 12. GPIB Addresses	56
The LAN/GPIB Gateway	57
Figure 23. Rear Panel Wiring Diagram for LAN/GPIB Gateway	58
The System Controller	59
Table 13. Personal Computer Requirements	59
Table 14. UNIX Workstation Requirements	59
The Rack Cabinet	60
Performance Characteristics and Specifications	61
Table 15. Supplemental System Characteristics	61
Interference Standards	61
Performance Modeling System Performance Specifications	61
RF Subsystem Performance Specifications	62
DC Subsystem Specifications	62
Bias Network Characteristics	62

2 Installing the System

To prepare the installation site	64
Table 16. Environmental Requirements	64
Table 17. Electrical Requirements	64
To receive the system	65
To unpack the shipment crate containing the rack cabinet	66
To verify the shipment	68
Table 18. Replaceable Parts	69
To install the work surface	74
To ensure your safety while using the system	76
Precautions for Performing Floating-Ground Measurements	78
To perform floating-ground measurements	78

Precautions for Avoiding Electrostatic Discharge	79
To connect the bias networks	80
Agilent 4156C Systems	80
Agilent 4156C Systems with Agilent 41501B Expander Box	82
Agilent E5260A/70B Systems	84
To switch on power to the system	87
To configure the LAN/GPIB gateway for functional verification	89

3 Verifying System Functionality

To choose a verification process	92
Understanding the System Functional Verification Test	94
Required Tools	94
Performing the System Functional Verification Test	95
If you encounter a problem	101

4 Servicing the System

To troubleshoot the system	104
To remove or replace a system component	105
To order replacement parts	106
To receive additional assistance	107
Table 19. Contacting Agilent Technologies	107
To package the system for transport	108

A Enhancing Measurement Accuracy

To enhance measurement accuracy	112
Understanding System Measurement Calibration	114
Required Tools	114
Performing a Coaxial System Measurement Calibration	115
If you encounter a problem	116
Periodic System Component Calibration	117

B DC Subsystem Functional Verification Test

Understanding the DC Subsystem Functional Verification Test	120
Required Tools	120
Performing the DC Subsystem Functional Verification Test	121
If you encounter a problem	121

If you encounter a problem 122

C RF Subsystem Functional Verification Test

Understanding the RF Subsystem Functional Verification Test 124

Required Tools 124

Performing the RF Subsystem Functional Verification Test 125

If you encounter a problem 127

D CV Subsystem Functional Verification Test

Understanding the CV Subsystem Functional Verification Test 130

Required Tools 130

Performing the CV Subsystem Functional Verification Test 131

If you encounter a problem 132

E 1/f Noise Subsystem Functional Verification Test

Understanding the 1/f Noise Subsystem Functional Verification Test 134

Required Tools 134

Performing the 1/f Noise Subsystem Functional Verification Test 135

If you encounter a problem 136

F Understanding the Bias Networks

Features 138

Characteristics 139

Table 20. 11612V Option K11/K21 Bias Network Characteristics 139

Operation 140

Figure 24. Bias Network Schematic 140

G Network Analyzer Performance Specification Summary

Network Analyzer System Performance 142

Maximum Output Power 142

Dynamic Range 142

Measurement Port Characteristics 143

Measurement Uncertainty 143

Index

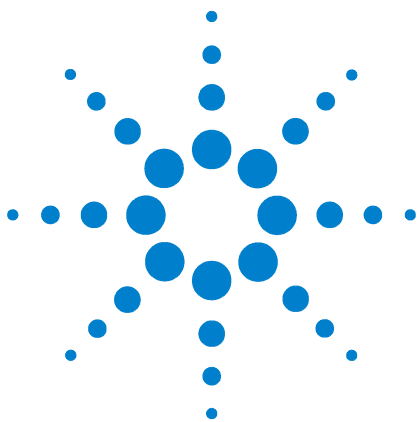

1 Introducing the Agilent 85225F Performance Modeling System

Performance Modeling System Configuration Overview	18
RF and DC Measurement System Configuration	19
CV, RF, and DC Measurement System Configuration	33
1/f Noise, CV, RF, and DC Measurement System Configuration	45
The System Controller	59
Performance Characteristics and Specifications	61

Related Topics

- ["Installing the System"](#) on page 63
- ["Network Analyzer Performance Specification Summary"](#) on page 141
- ["Understanding the Bias Networks"](#) on page 137

Use this chapter to familiarize yourself with the measurement configurations of the performance modeling system. This chapter introduces the system by describing its operational theory, integration, and performance.

Performance Modeling System Configuration Overview

The standard Agilent 85225F performance modeling system measures the DC and RF performance of active and passive devices. You may configure the Agilent 85225F performance modeling system to measure CV and 1/f noise with the addition of optional instrumentation and IC-CAP 1/f noise measurement modules.

For RF and DC performance measurement system configurations, see [“RF and DC Measurement System Configuration”](#) on page 19.

For CV, RF, and DC performance measurement system configurations, see [“CV, RF, and DC Measurement System Configuration”](#) on page 29.

For 1/f noise, CV, RF, and DC performance measurement system configurations, see [“1/f Noise, CV, RF, and DC Measurement System Configuration”](#) on page 45.

RF and DC Measurement System Configuration

In conjunction with a compatible controller running 85190-Series IC-CAP software, the Agilent 85225F performance modeling system measures the DC and RF performance of active and passive devices. The IC-CAP software then extracts the device parameters and displays the results.

The Agilent 85225F performance modeling system is the integration of rack-mounted RF and DC subsystems, bias networks, and a system controller*, as shown in [Figure 1](#)†.

Figure 1 System Block Diagram

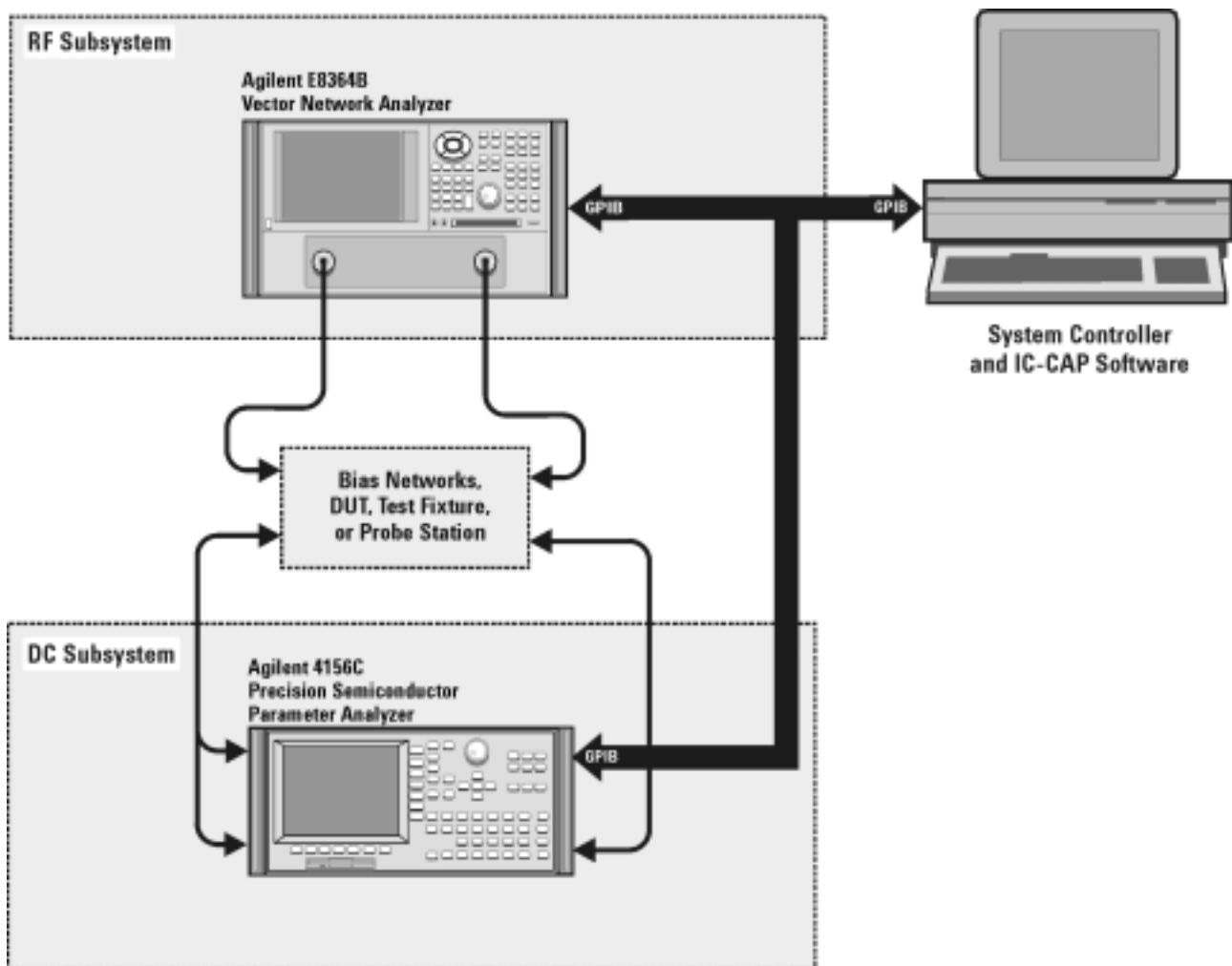

* The system controller is not included and must be provided.

† This block diagram shows a system with an Agilent 4156C as the DC subsystem. Other instrumentation may be used. See ["The DC Subsystem"](#) on page 20.

The RF Subsystem

S-parameter device characterization is provided by the RF subsystem.

The RF subsystem contains the Agilent E8364B PNA Series vector network analyzer.

Its integrated synthesizer supplies a swept or CW RF source signal from 10 MHz* to 50 GHz.

The integrated test set separates the RF source signal into reference and test signals, and provides RF connection via cables and adapters to the external bias networks.

The DC Subsystem

Precision DC characterization and bias for the S-parameter measurements are provided by one of the following three DC subsystems.

The DC subsystem may contain one of the following three instruments.

Agilent 4156C Precision Semiconductor Parameter Analyzer

The Agilent 4156C precision semiconductor parameter analyzer provides DC force (supply) and sense (measure) capability from its HRSMUs (high resolution source/monitor units).

Optionally, the Agilent 4156C may be configured with a 41501B SMU PGU expander is connected to and controlled by the 4156C via the expander box interface. The 41501B provides a GNDU (active ground unit) and, depending on option configuration, an HPSMU (high-power source/monitor unit), two MPSMUs (medium-power source monitor units), and/or two PGUs (pulse generator units).

The DC signals are routed through feedthrough panels via triaxial cables to the bias networks.

Agilent E5260A 8-Slot High Speed Parametric Measurement Mainframe

The Agilent E5260A provides DC force (supply) and sense (measure) capability from its plug-in source/monitor units.

The Agilent E5290A plug-in high speed high power source/monitor unit provides up to 200 volts of potential and 1 amp of current to the device under test.

The Agilent E5291A plug-in high speed medium power source/monitor unit provides up to 100 volts of potential and 200 milliamps of current to the device under test.

* Due to the minimum operating frequency of the bias networks, the performance modeling system low end frequency range is 45 MHz.

Agilent E5270B 8-Slot Precision Parametric Measurement Mainframe

The Agilent E5270B provides DC force (supply) and sense (measure) capability from its plug-in source/monitor units.

The Agilent E5280A plug-in high power source/monitor unit provides up to 200 volts of potential and 1 amp of current to the device under test.

The Agilent E5281A plug-in medium power source/monitor unit provides up to 100 volts of potential and 200 milliamps of current to the device under test.

CAUTION

Exposing the bias networks to currents greater than 500 milliamps or voltages greater than 40 volts will result in severe damage. Do not exceed these values while using the bias networks. Remove the bias networks from the circuit if greater voltages or currents are required.

The Bias Networks

The Agilent 11612V Option K11 and K21 bias networks combine the DC and RF signals and apply them simultaneously to the device under test (DUT). The bias networks are configured with 2.4 mm DC/RF output connectors for connection to a DUT, a test fixture, or probe station, as shown in [Figure 21](#) on page 54.

Component Integration

System component integration is performed at the Agilent Technologies factory. The individual components are placed into the rack, and the required cabling is connected between the instruments.

After factory integration, the system is tested to verify functional performance.

The Agilent 85225F performance modeling system includes the following components, as shown in [Figure 2](#) on page 23:

- Agilent E8364B PNA Series vector network analyzer
- Agilent 4156C precision semiconductor parameter analyzer (or optionally Agilent E5260A or E5270B)
- Agilent 11612V Option K11 bias network (port 1)
- Agilent 11612V Option K21 bias network (port 2)
- Agilent 85133F flexible test port cable set
- Agilent E3661B 1.6 meter rack cabinet
- filler panels, feedthrough panels, work surface, cables, and adapters

For systems with Agilent 4156C, front panel connections are listed in [Table 3](#) on page 24 and illustrated in [Figure 3](#) on page 25.

For systems with Agilent 4156C, rear panel connections are listed in [Table 5](#) on page 28 and illustrated in [Figure 5](#) on page 29.

For systems with Agilent E5260A or E5270B, front panel connections are listed in [Table 4](#) on page 26 and illustrated in [Figure 4](#) on page 27.

For systems with Agilent E5260A or E5270B, rear panel connections are listed in [Table 6](#) on page 30 and illustrated in [Figure 6](#) on page 31.

Figure 2 System Components

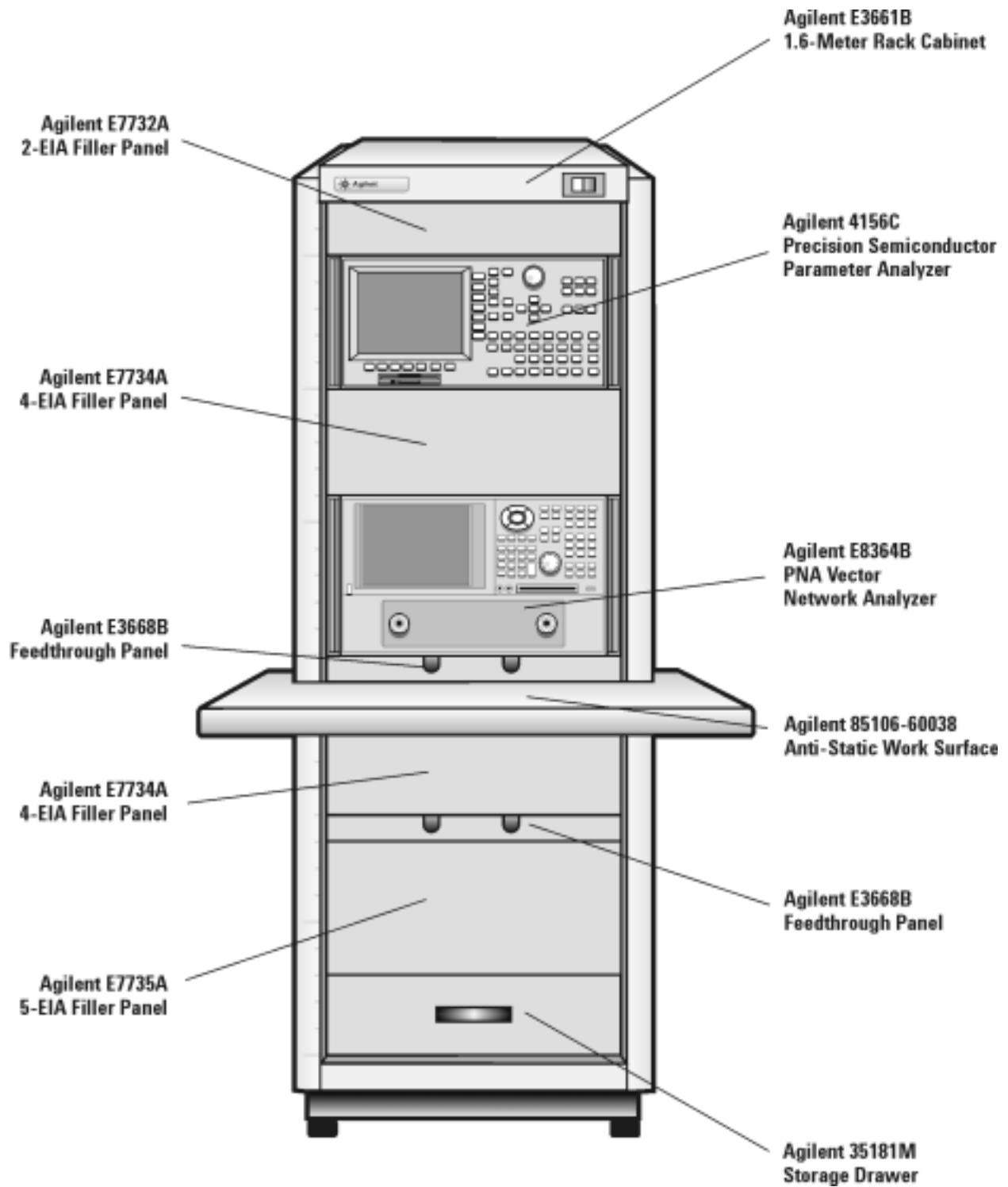

Table 3 Front Panel System Connections, with Agilent 4156C

Component Information				Connection Information			
Designator	Model Number	Description	Connector Type	From Instrument	Connector Labeled	To Connector Labeled	On Instrument
1	16494A Option 002	Triaxial cable	Triax BNC	4156C HRSMU1	SENSE	DC SENSE	11612V K11
2	16494A Option 002	Triaxial cable	Triax BNC	4156C HRSMU1	FORCE	DC FORCE	11612V K11
3	16494A Option 002	Triaxial cable	Triax BNC	4156C HRSMU2	SENSE	DC SENSE	11612V K21
4	16494A Option 002	Triaxial cable	Triax BNC	4156C HRSMU2	FORCE	DC FORCE	11612V K21
5	16494A Option 002	Triaxial cable	Triax BNC	4156C HRSMU3	FORCE	GNDU	11612V K21
6	85133F	Flexible test port cable	2.4 mm	E8364B	PORT 1	RF IN	11612V K11
7	85133F	Flexible test port cable	2.4 mm	E8364B	PORT 2	RF IN	11612V K21

Figure 3 Front Panel Connections with Agilent 4156C

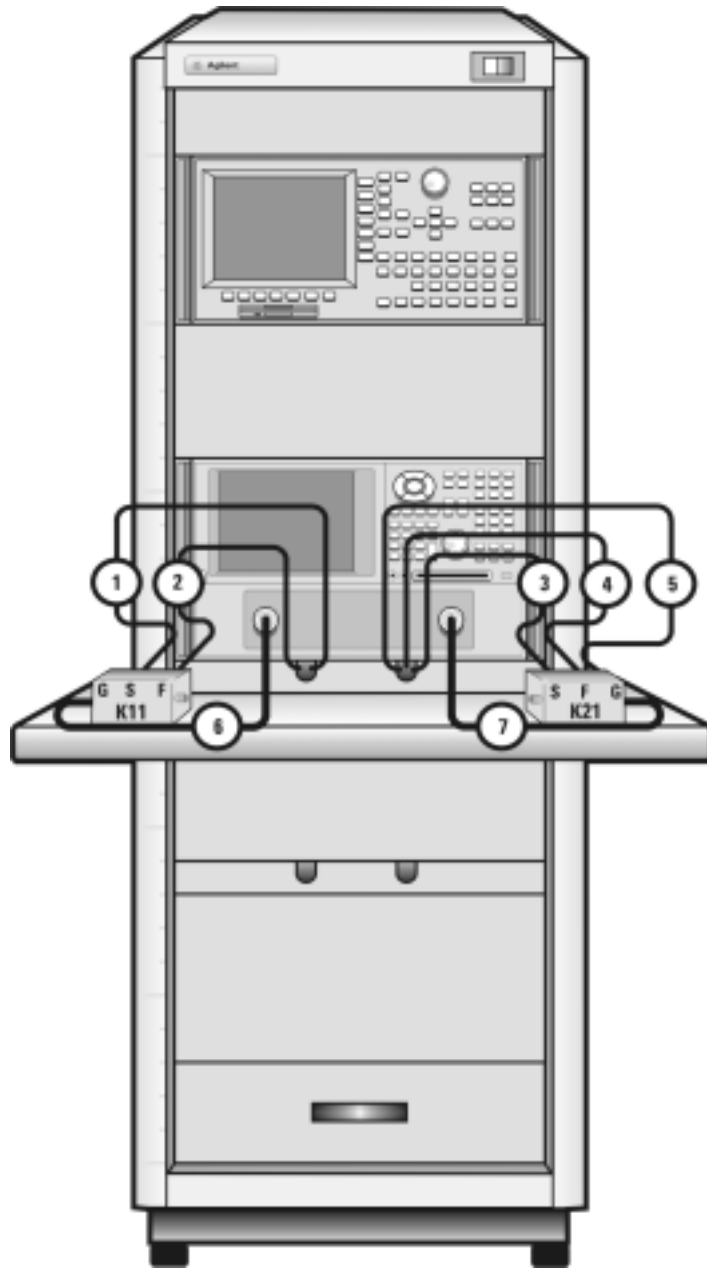

Table 4 Front Panel System Connections, with Agilent E5260A or E5270B

Component Information				Connection Information			
Designator	Model Number	Description	Connector Type	From Instrument	Connector Labeled	To Connector Labeled	On Instrument
1	16494A Option 002	Triaxial cable	Triax BNC	E5260A/70B HPSMU1	SENSE	DC SENSE	11612V K21
2	16494A Option 002	Triaxial cable	Triax BNC	E5260A/70B HPSMU1	FORCE	DC FORCE	11612V K21
3	16494A Option 002	Triaxial cable	Triax BNC	E5260A/70B MPSMU3	FORCE	DC FORCE	11612V K11
4	16494A Option 002	Triaxial cable	Triax BNC	E5260A/70B MPSMU3	SENSE	DC SENSE	11612V K11
5	16493L Option 002	Triaxial GNDU cable	Triax BNC	E5260A/70B GNDU	GNDU	GNDU	11612V K21
6	85133F	Flexible test port cable	2.4 mm	E8364B	PORT 1	RF IN	11612V K11
7	85133F	Flexible test port cable	2.4 mm	E8364B	PORT 2	RF IN	11612V K21

Figure 4 Front Panel Wiring Diagram with Agilent E5260A or E5270B

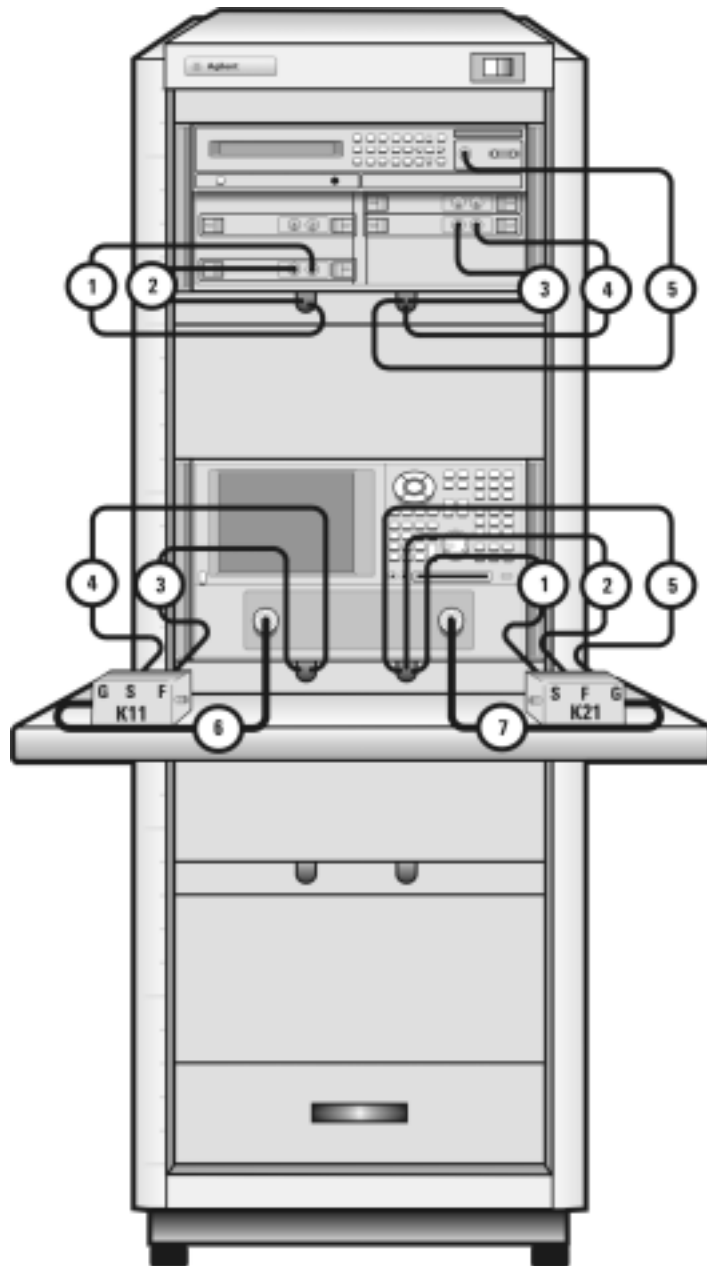

Table 5 Rear Panel System Connections with Agilent 4156C

Component Information				Connection Information			
Designator	Model Number	Description	Connector Type	From Instrument	Connector Labeled	To Connector Labeled	On Instrument
1	16494A Option 002	Triaxial cable	Triax BNC	4156C HRSMU2	FORCE	DC FORCE	11612V K21
2	16494A Option 002	Triaxial cable	Triax BNC	4156C HRSMU2	SENSE	DC SENSE	11612V K21
3	16494A Option 002	Triaxial cable	Triax BNC	4156C HRSMU1	FORCE	DC FORCE	11612V K11
4	16494A Option 002	Triaxial cable	Triax BNC	4156C HRSMU1	SENSE	DC SENSE	11612V K11
5	16494A Option 002	Triaxial cable	Triax BNC	4156C HRSMU3	FORCE	GNDU	11612V K21
6	10833D	GPIB cable	GPIB	4156C	GPIB	GPIB	E8364B
7	10833C	GPIB cable	GPIB	E8364B	GPIB	GPIB	Controller

NOTE

If the system does not include an Agilent 41501B SMU/PGU expander, use the Agilent 4156C HRSMU3 FORCE as the GND (ground unit).

Figure 5 Rear Panel Wiring Diagram with Agilent 4156C

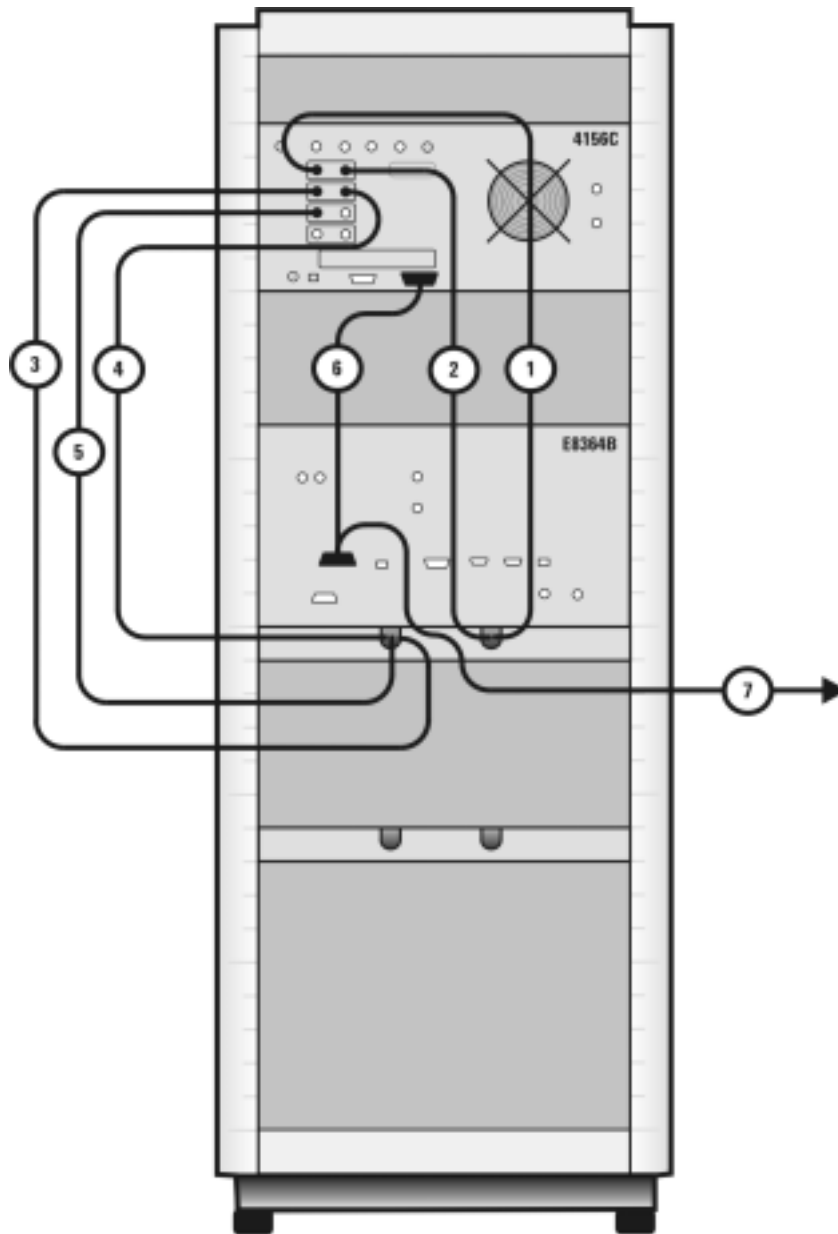

Table 6 Rear Panel System Connections with Agilent E5260A or E5270B

Component Information				Connection Information			
Designator	Model Number	Description	Connector Type	From Instrument	Connector Labeled	To Connector Labeled	On Instrument
1	10833A	GPIB cable	GPIB	4156C	GPIB	GPIB	E8364B
2	10833C	GPIB cable	GPIB	E8364B	GPIB	GPIB	Controller

Figure 6 Rear Panel Wiring with Agilent E5260A or E5270B

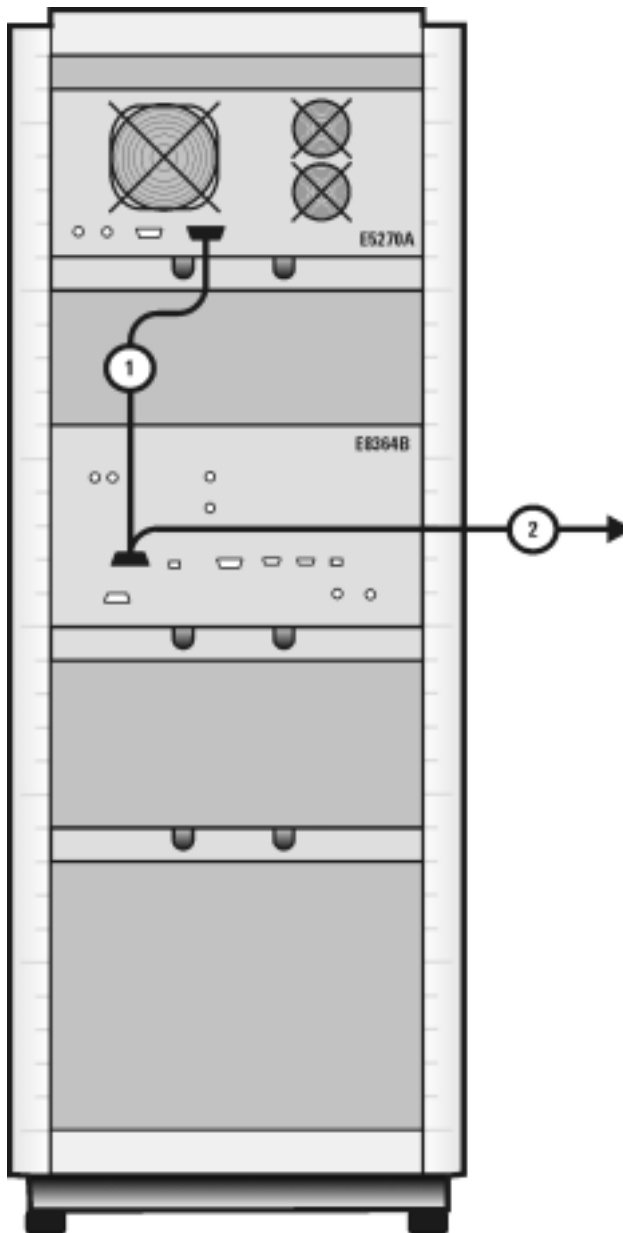
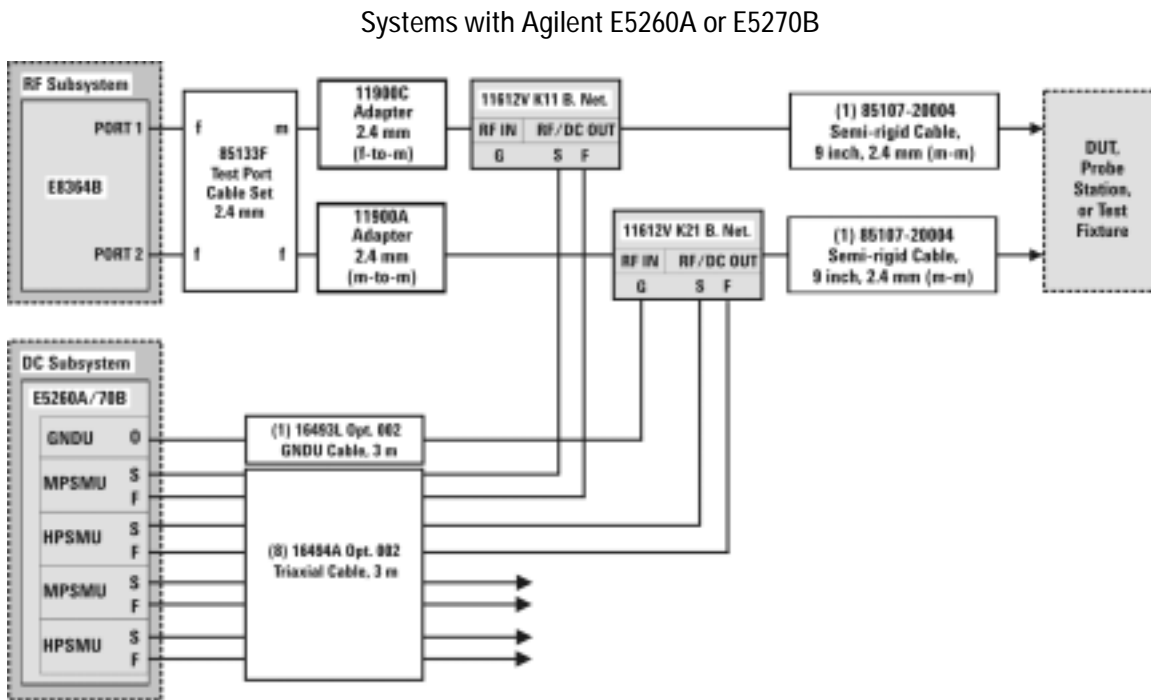
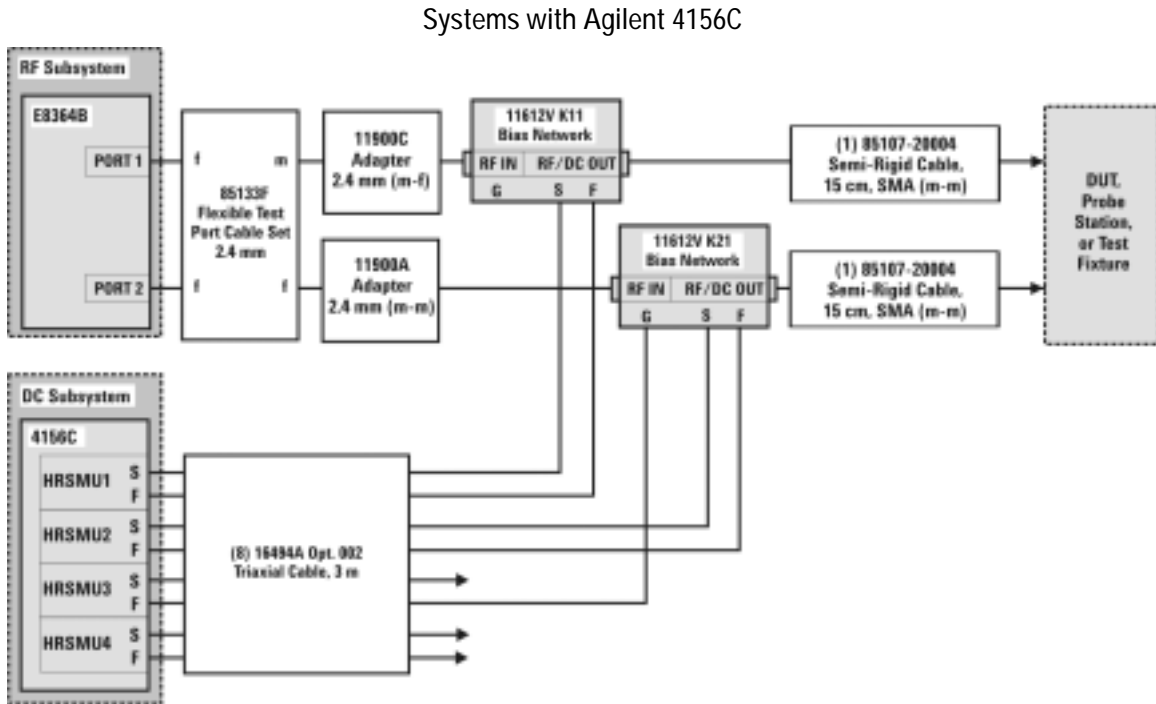

Figure 7 DC/RF Cabling Diagram - DC and RF Configuration



CV, RF, and DC Measurement System Configuration

With the addition of a precision LCR meter, the Agilent 85225F performance modeling system measures the DC, RF, and CV performance of active and passive devices. The IC-CAP software then extracts the device parameters and displays the results.

The Agilent 85225F performance modeling system for CV, RF, and DC measurement is the integration of rack-mounted RF, DC, and CV subsystems, bias networks, and a system controller, as shown in [Figure 8](#).

Figure 8 System Block Diagram

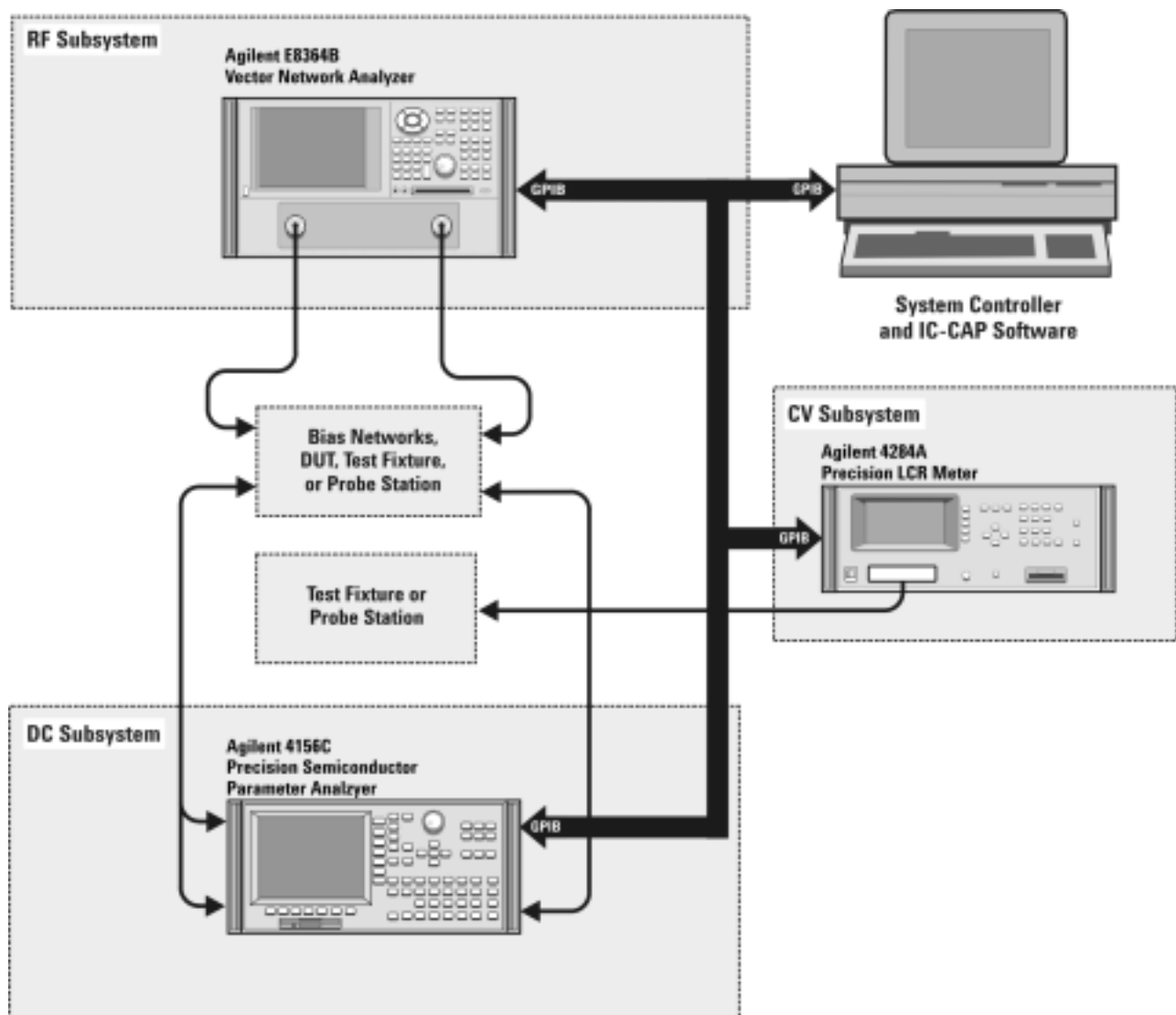

The CV Subsystem

The Agilent 4284A precision LCR meter provides a wide 20 Hz to 1 MHz test frequency range and superior test-signal performance, allowing CV testing to the most commonly-used test standards, such as IEC/MIL, and under conditions that simulate the intended application.

Optionally, the system can be configured with the Agilent E5250A low leakage switch mainframe. The Agilent E5250A is used for precise parametric test. It improves measurement efficiency by eliminating the need to manually change the probe positions on a manual probe station. The E5250A is used to route signals from the DC and CV subsystems to the probe card cable, and on to the probe card and probe station.

Component Integration

System component integration is performed at the Agilent Technologies factory. The individual components are placed into the rack, and the required cabling is connected between the instruments.

After factory integration, the system is tested to verify functional performance.

The Agilent 85225F performance modeling system includes the following components, as shown in [Figure 18](#) on page 49:

- Agilent E8364B PNA Series vector network analyzer
- Agilent 4156C precision semiconductor parameter analyzer (or optionally Agilent E5260A or E5270B)
- Agilent 11612V Option K11 bias network (port 1)
- Agilent 11612V Option K21 bias network (port 2)
- Agilent 4284A precision LCR meter
- Agilent 85133F flexible test port cable set
- Agilent E3661B 1.6 meter rack cabinet
- filler panels, feedthrough panels, work surface, cables, and adapters

System front panel connections are listed in [Table 10](#) on page 50 and illustrated in [Figure 19](#) on page 51.

System rear panel connections are listed in [Table 11](#) on page 52 and illustrated in [Figure 20](#) on page 53.

Figure 9 System Components

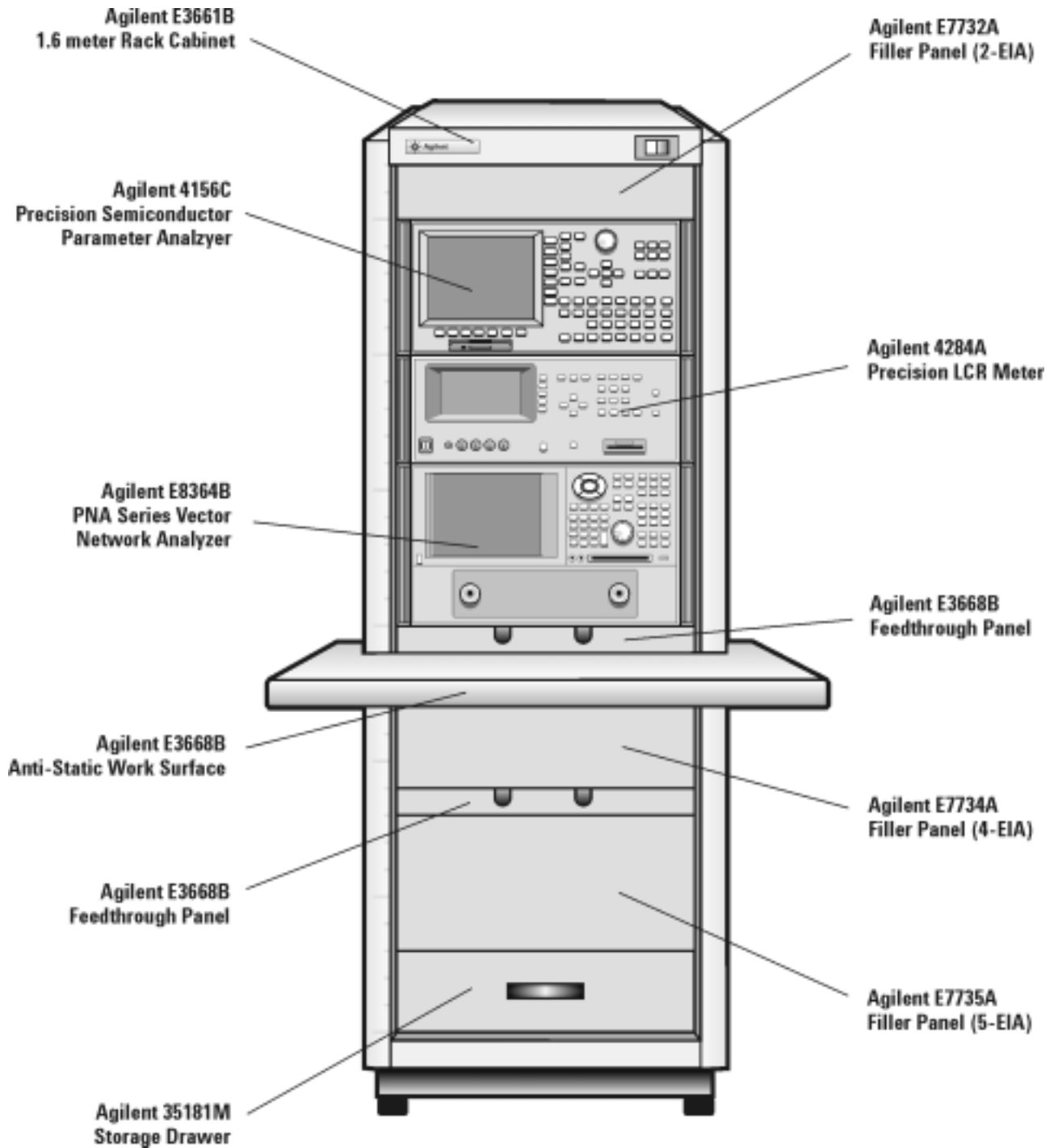

Table 7 Front Panel System Connections

Component Information				Connection Information			
Designator	Model Number	Description	Connector Type	From Instrument	Connector Labeled	To Connector Labeled	On Instrument
1	16494A Option 002	Triaxial cable	Triax BNC	4156C HRSMU1	FORCE	DC FORCE	11612V K11
2	16494A Option 002	Triaxial cable	Triax BNC	4156C HRSMU1	SENSE	DC SENSE	11612V K11
3	16494A Option 002	Triaxial cable	Triax BNC	4156C HRSMU2	FORCE	DC FORCE	11612V K21
4	16494A Option 002	Triaxial cable	Triax BNC	4156C HRSMU2	SENSE	DC SENSE	11612V K21
5	16494A Option 002	Triaxial GNDU cable	Triax BNC	4156C HRSMU3	FORCE	GNDU	11612V K21
6	85133F	Flexible test port cable	2.4 mm	E8364B	PORT 1	RF IN	11612V K11
7	85133F	Flexible test port cable	2.4 mm	E8364B	PORT 2	RF IN	11612V K21
8	16048D	LCR meter test cable	BNC	4284A	UNKNOWN		Test fixture or probe station

Figure 10 Front Panel Wiring Diagram

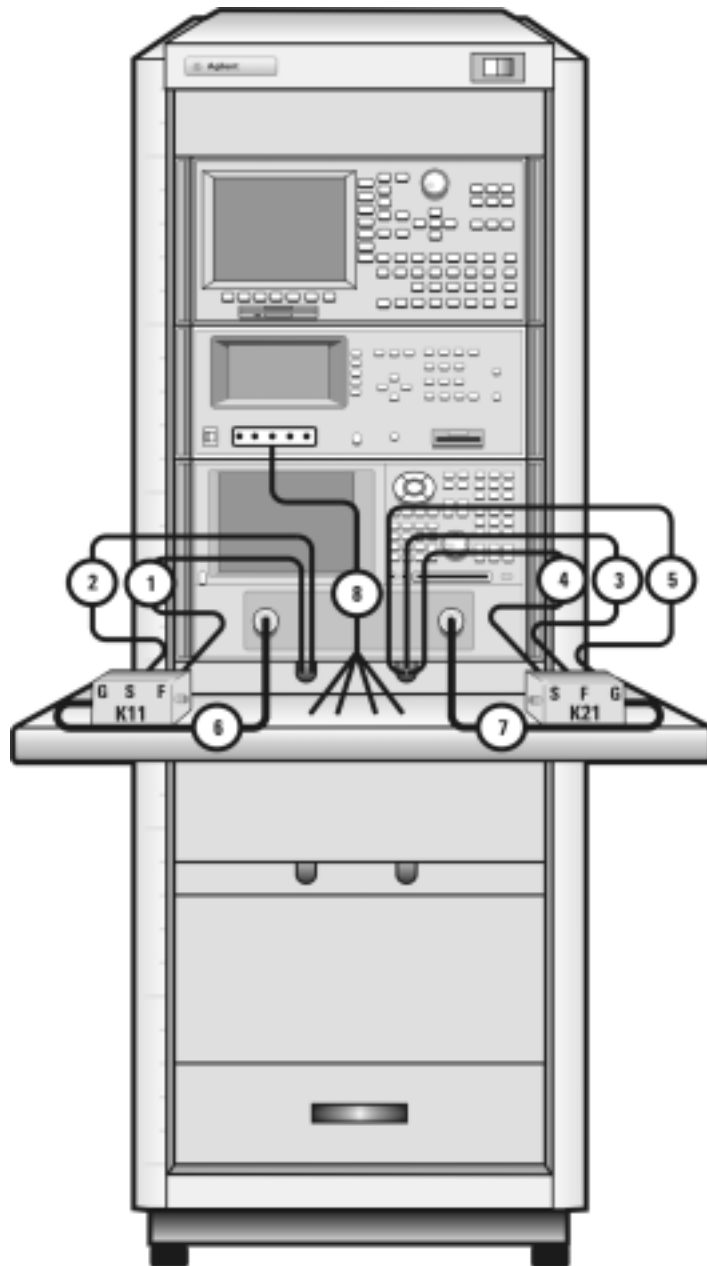

Table 8 Rear Panel System Connections

Component Information				Connection Information			
Designator	Model Number	Description	Connector Type	From Instrument	Connector Labeled	To Connector Labeled	On Instrument
1	16494A Option 002	Triaxial cable	Triax BNC	4156C HRSMU1	FORCE	DC FORCE	11612V K11
2	16494A Option 002	Triaxial cable	Triax BNC	4156C HRSMU1	SENSE	DC SENSE	11612V K11
3	16494A Option 002	Triaxial cable	Triax BNC	4156C HRSMU2	FORCE	DC FORCE	11612V K21
4	16494A Option 002	Triaxial cable	Triax BNC	4156C HRSMU2	SENSE	DC SENSE	11612V K21
5	16494A Option 002	Triaxial cable	Triax BNC	4156C HRSMU3	FORCE	GNDU	11612V K21
6	10833D	GPIB cable	GPIB	4156C	GPIB	GPIB	4284A
7	10833D	GPIB cable	GPIB	4284A	GPIB	GPIB	E8364B
8	10833C	GPIB cable	GPIB	E8364B	GPIB	GPIB	Controller

Figure 11 Rear Panel Wiring Diagram

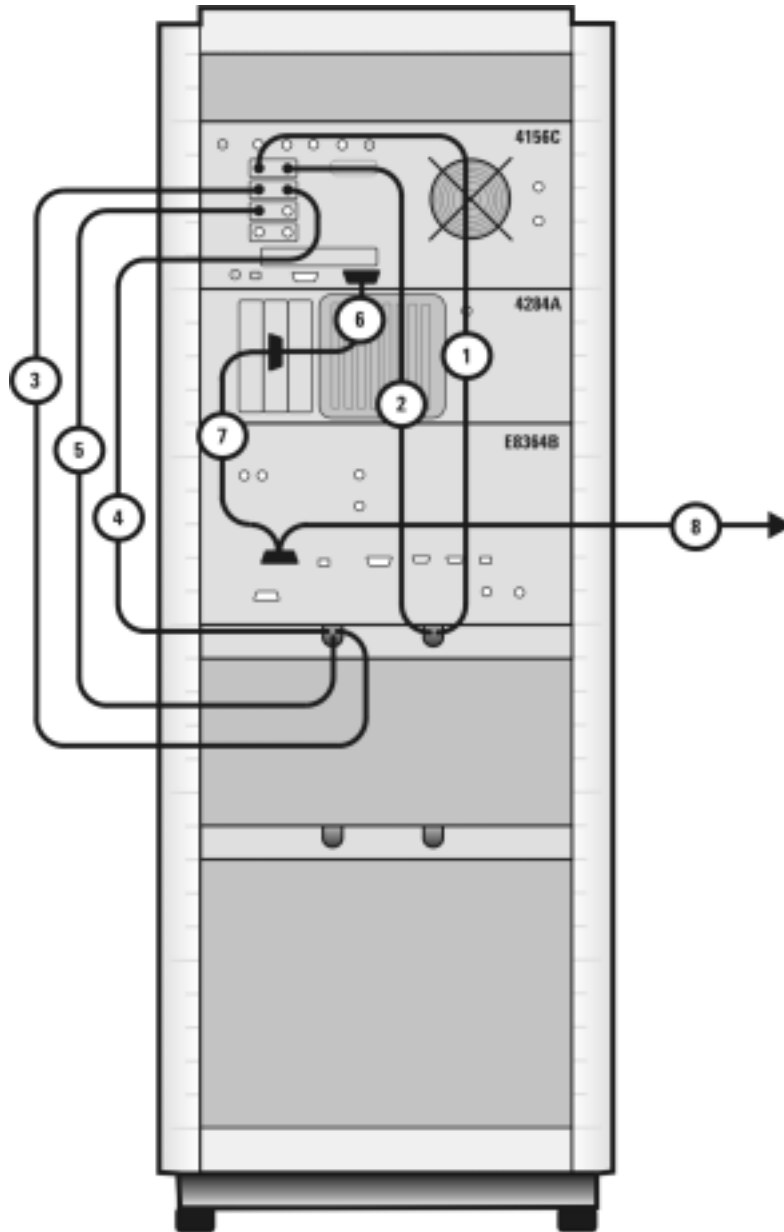

Figure 12 DC/RF Cabling Diagram - DC and RF Configuration

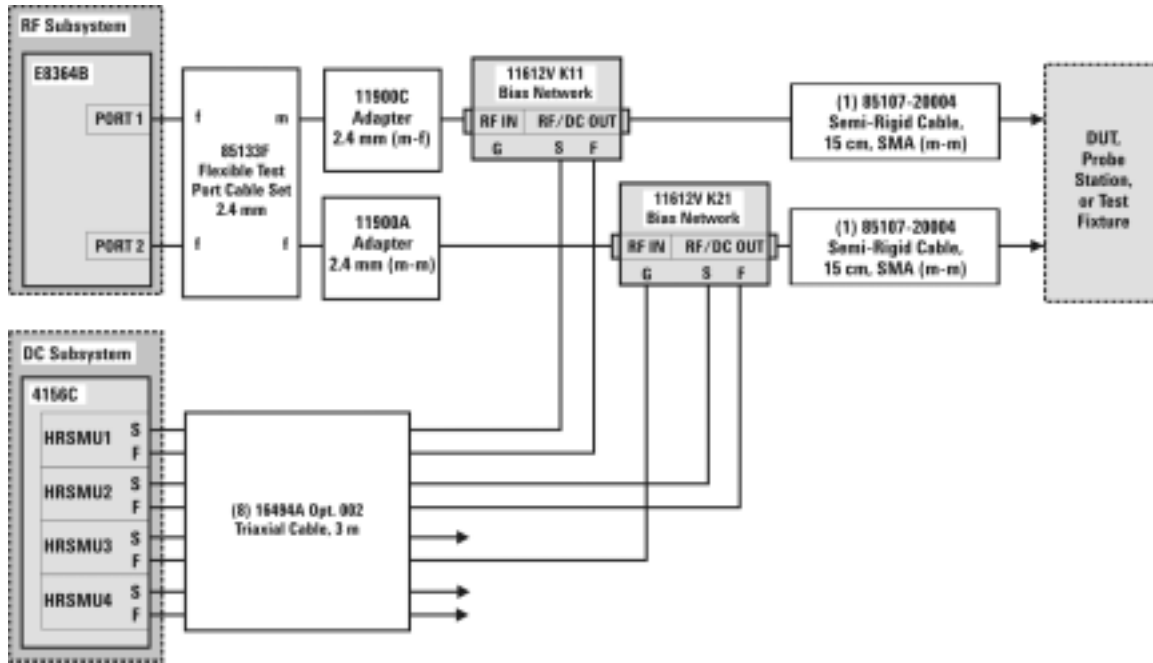
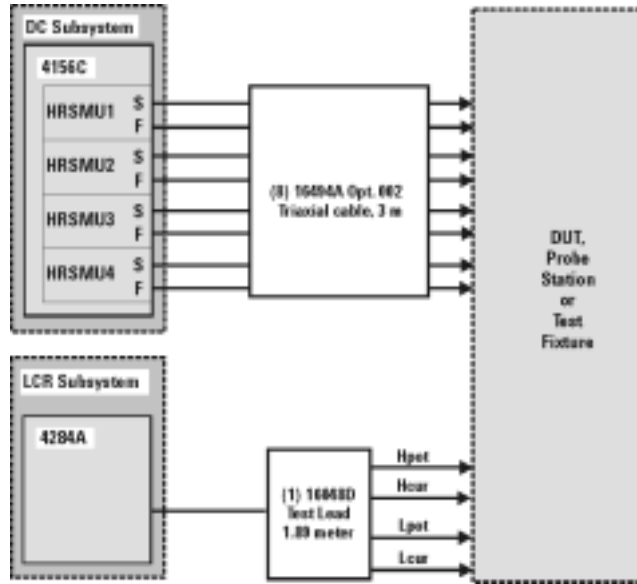

Figure 13 DC/RF Cabling Diagram - Parametric Configuration



The Low Leakage Switch Mainframe

The Agilent E5250A is used for precise parametric test. It improves measurement efficiency by eliminating the need to manually change the probe positions on a manual probe station. The E5250A is used to route signals from the 4156C and the 4284A to the probe card cable, and on to probe card and probe station.

Table 9 Rear Panel Connections, including Low Leakage Switch Mainframe

Component Information				Connection Information			
Designator	Model Number	Description	Connector Type	From Instrument	Connector Labeled	To Connector Labeled	On Instrument
1	16494A Option 002	Triaxial cable	Triax BNC	4156C HRSMU1	SENSE	SMU INPUT 2	E5250A
2	16494A Option 002	Triaxial cable	Triax BNC	4156C HRSMU1	FORCE	SMU INPUT 1	E5250A
3	16494A Option 002	Triaxial cable	Triax BNC	4156C HRSMU2	FORCE	SMU INPUT 3	E5250A
4	16494A Option 002	Triaxial cable	Triax BNC	4156C HRSMU2	SENSE	SMU INPUT 4	E5250A
5	16048D	LCR meter test cable	BNC	4284A	UNKNOWN	T1 & T2 (CV1 & CV2)	E5250A
6	10833D	GPIB cable	GPIB	4156C	GPIB	GPIB	4284A
7	10833D	GPIB cable	GPIB	4284A	GPIB	GPIB	E8364B
8	10833D	GPIB cable	GPIB	E8364B	GPIB	GPIB	E5250A
9	10833C	GPIB cable	GPIB	E5250A	GPIB	GPIB	Controller
T1	1250-2405	BNC tee	BNC	4284A	HIpot/HIcur	CV1	E5250A
T2	1250-2405	BNC tee	BNC	4284A	LOpot/LOcur	CV2	E5250A

Figure 14 Rear Panel Wiring Diagram including Low Leakage Switch Mainframe

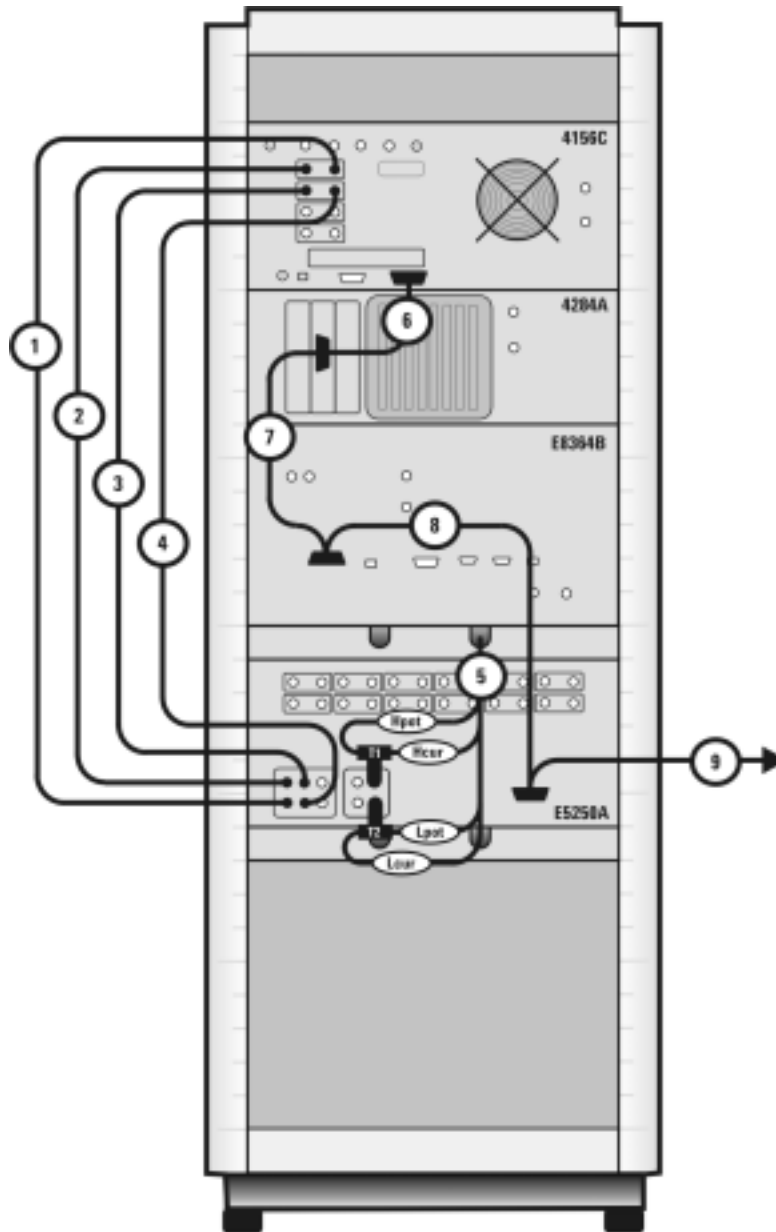
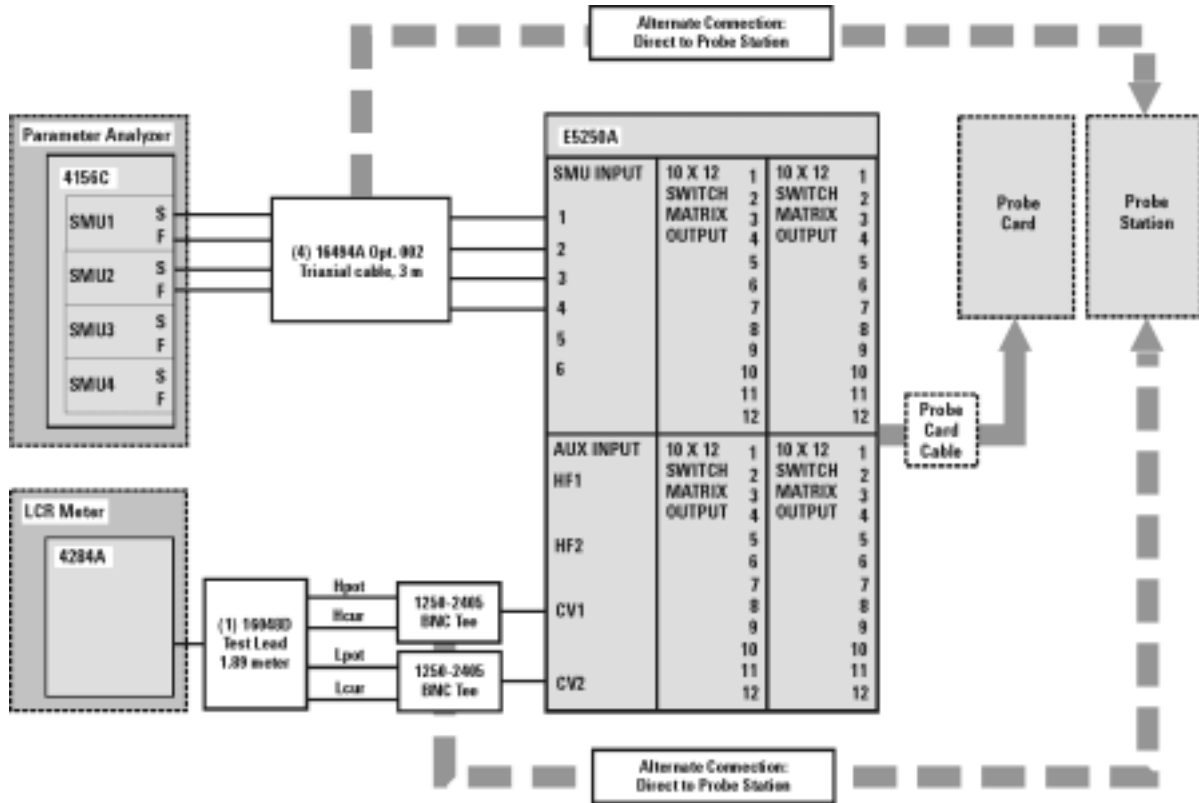

Figure 15 DC/RF Cabling Diagram - Parametric Configuration with Low Leakage Switch Mainframe



1/f Noise, CV, RF, and DC Measurement System Configuration

With the addition of a dynamic signal analyzer and a precision LCR meter, the Agilent 85225F performance modeling system measures the DC, RF, CV, and 1/f noise performance of active and passive devices. The IC-CAP software then extracts the device parameters and displays the results.

The Agilent 85225F performance modeling system is the integration of rack-mounted RF and DC subsystems, a precision LCR meter, a dynamic signal analyzer, bias networks, and a system controller, as shown in [Figure 16](#).

Figure 16 System Block Diagram

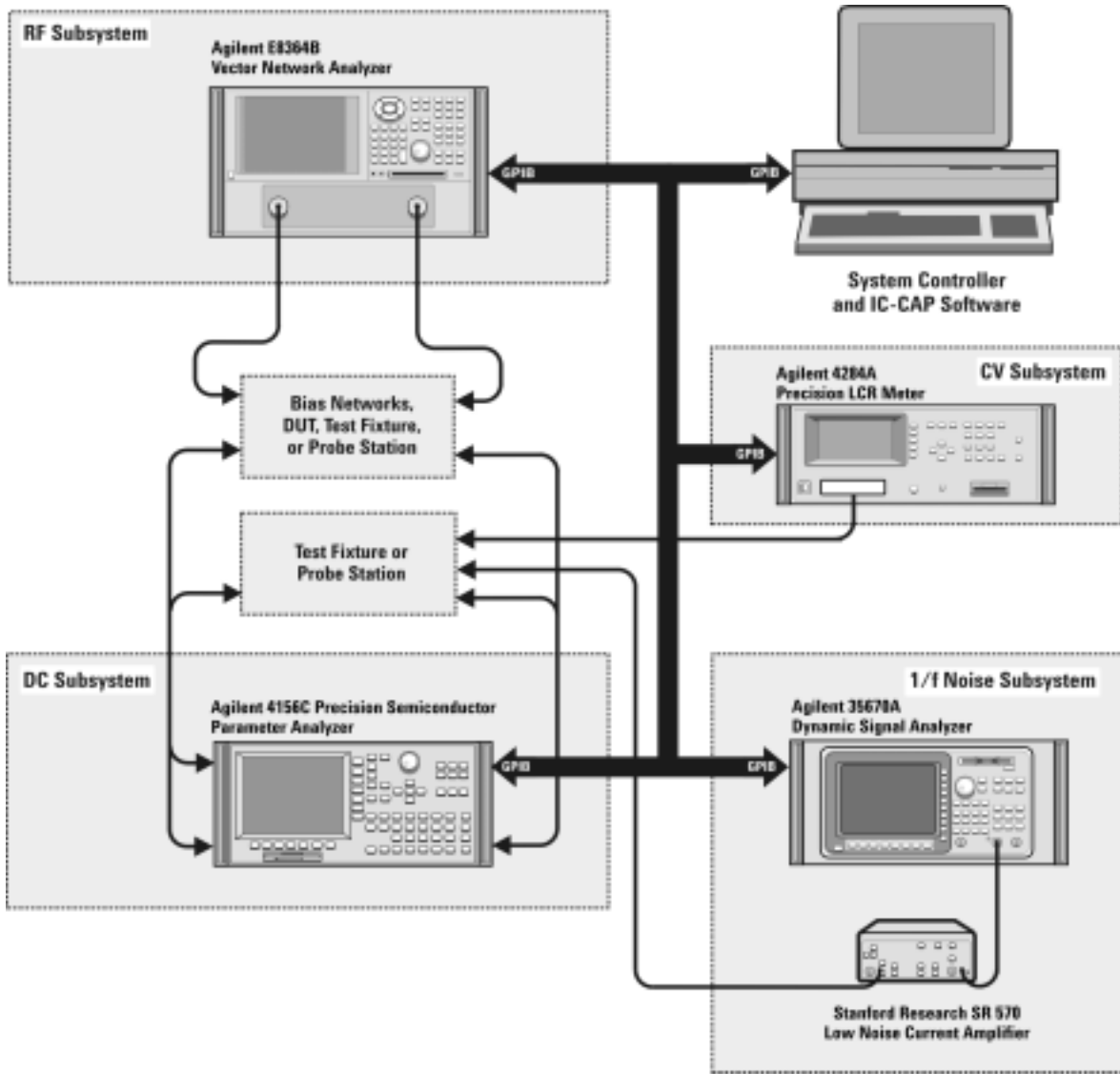

The 1/f Noise Subsystem

The Agilent 35670A dynamic signal analyzer (in conjunction with a customer-furnished Stanford Model SR570 low noise amplifier) measures the flicker noise (1/f noise) of active devices. Controlled by IC-CAP device modeling software, the dynamic signal analyzer generates reliable 1/f noise measurement data, which are analyzed and extracted in IC-CAP. Figure 17 shows the system configuration for 1/f noise measurements.

Figure 17 1/f Noise Measurement Block Diagram

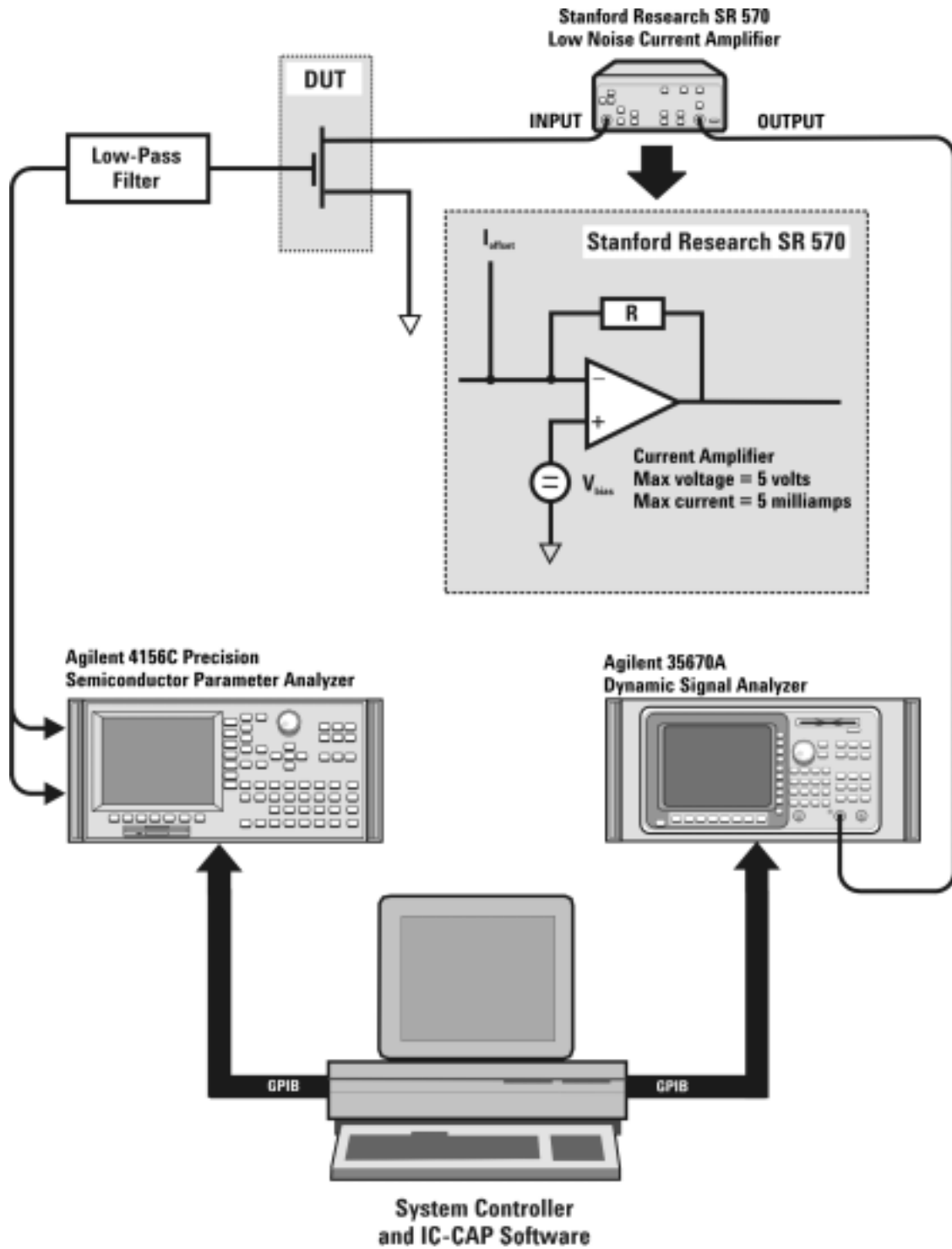

Component Integration

System component integration is performed at the Agilent Technologies factory. The individual components are placed into the rack, and the required cabling is connected between the instruments.

After factory integration, the system is tested to verify functional performance.

The Agilent 85225F performance modeling system includes the following components, as shown in [Figure 18](#) on page 49:

- Agilent E8364B PNA Series vector network analyzer
- Agilent 4156C precision semiconductor parameter analyzer with optional Agilent 41501B SMU/PGU expander (or optionally Agilent E5260A or E5270B)
- Agilent 11612V Option K11 bias network (port 1)
- Agilent 11612V Option K21 bias network (port 2)
- Agilent 4284A precision LCR meter
- Agilent 35670A dynamic signal analyzer
- Stanford Research SR 570 low noise current amplifier*
- Agilent 85133F flexible test port cable set
- Agilent E3661B 1.6 meter rack cabinet
- filler panels, feedthrough panels, work surface, cables, and adapters

System front panel connections are listed in [Table 10](#) on page 50 and illustrated in [Figure 19](#) on page 51.

System rear panel connections are listed in [Table 11](#) on page 52 and illustrated in [Figure 20](#) on page 53.

* Customer supplied, not included with system.

Figure 18 System Components

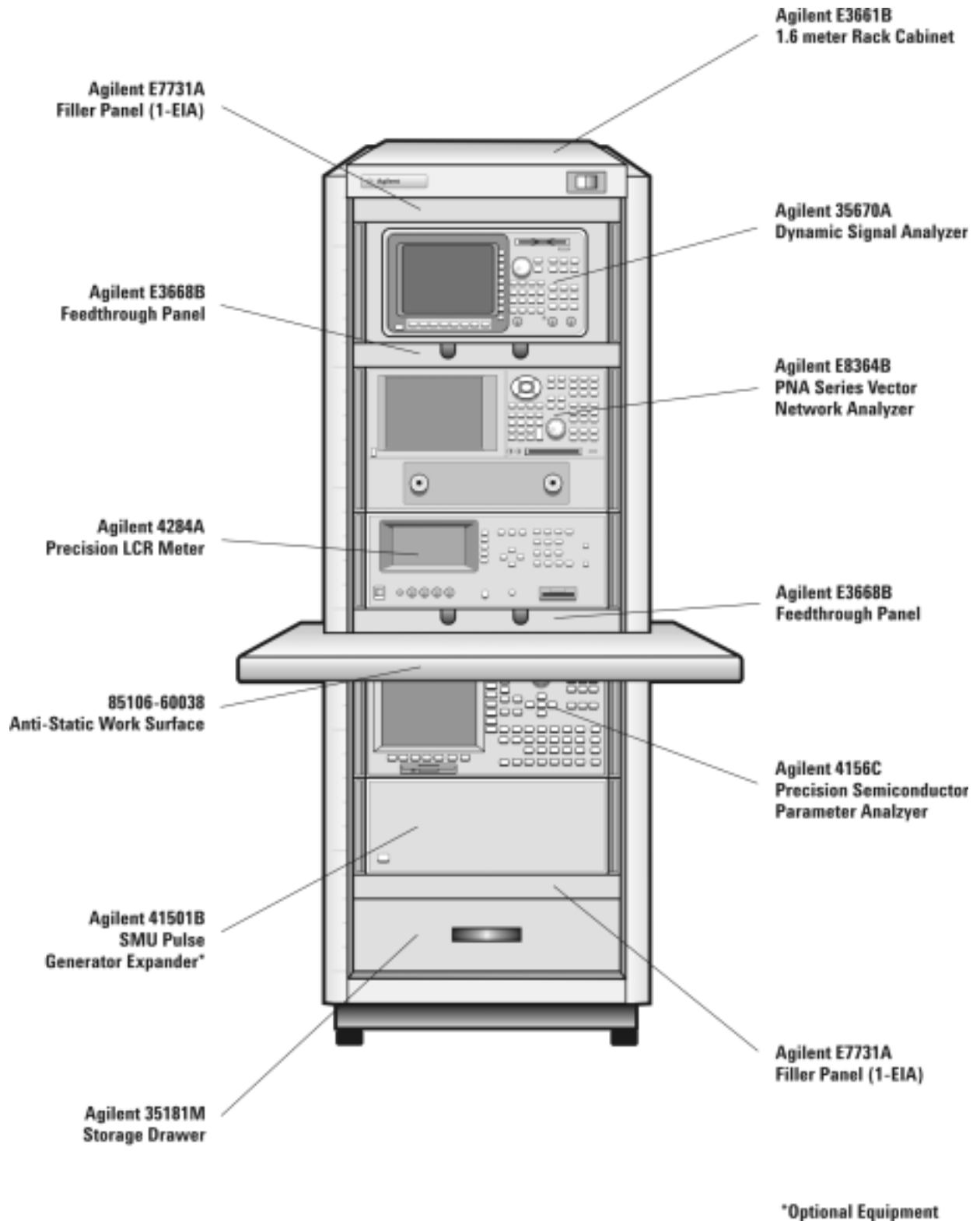

Table 10 Front Panel System Connections

Component Information				Connection Information			
Designator	Model Number	Description	Connector Type	From Instrument	Connector Labeled	To Connector Labeled	On Instrument
1	16494A Option 002	Triaxial cable	Triax BNC	41501B HPSMU	FORCE	DC FORCE	11612V K11
2	16494A Option 002	Triaxial cable	Triax BNC	41501B HPSMU	SENSE	DC SENSE	11612V K11
3	16494A Option 002	Triaxial cable	Triax BNC	4156C HRSMU1	FORCE	DC FORCE	11612V K21
4	16494A Option 002	Triaxial cable	Triax BNC	4156C HRSMU1	SENSE	DC SENSE	11612V K21
5	16493L Option 002	Triaxial GNDU cable	Triax BNC	41501B	GNDU	GNDU	11612V K21
6	85133F	Flexible test port cable	2.4 mm	E8364B	PORT 1	RF IN	11612V K11
7	85133F	Flexible test port cable	2.4 mm	E8364B	PORT 2	RF IN	11612V K21
8	16048D	LCR meter test cable	BNC	4284A	UNKNOWN		Test fixture or probe station
9	8120-1839	Coaxial cable	BNC	35670A	CH1		Test fixture or probe station

Figure 19 Front Panel Wiring Diagram

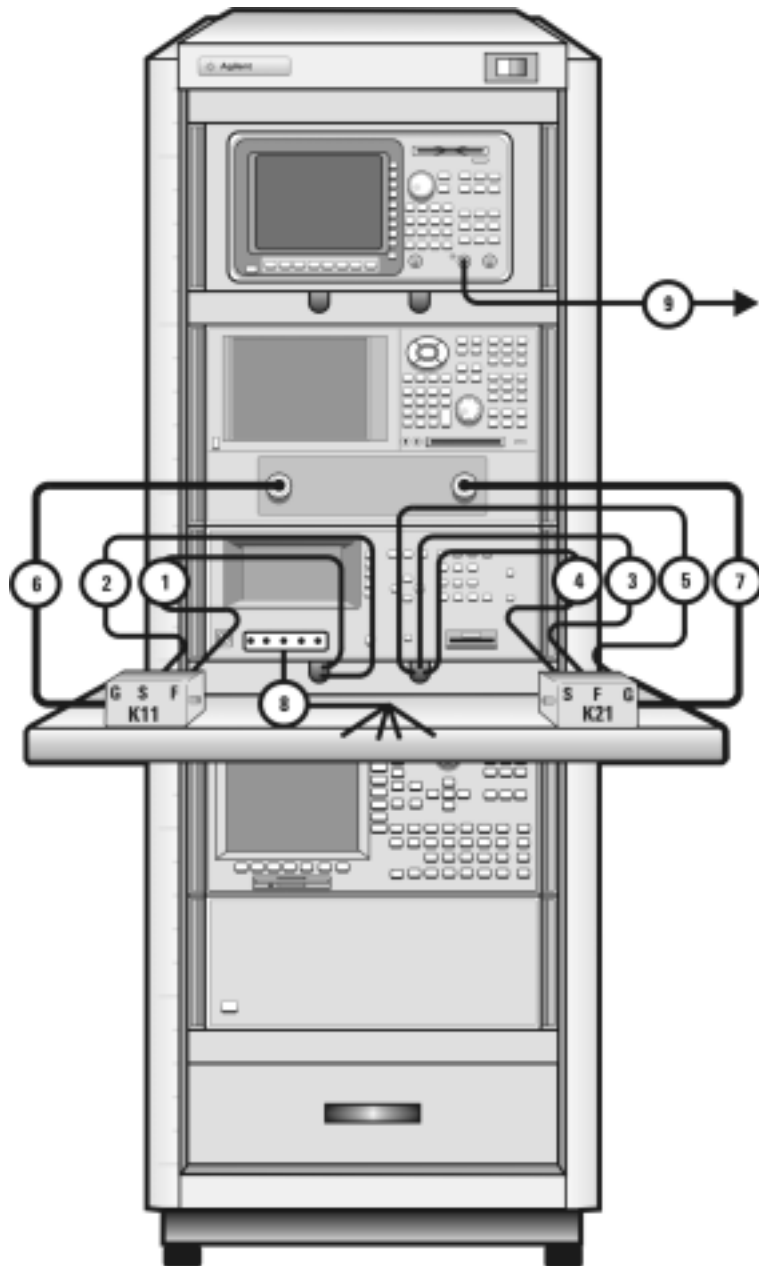

Table 11 Rear Panel System Connections

Component Information				Connection Information			
Designator	Model Number	Description	Connector Type	From Instrument	Connector Labeled	To Connector Labeled	On Instrument
1	16494A Option 002	Triaxial cable	Triax BNC	4156C HRSMU1	FORCE	DC FORCE	11612V K11
2	16494A Option 002	Triaxial cable	Triax BNC	4156C HRSMU1	SENSE	DC SENSE	11612V K11
3	16494A Option 002	Triaxial cable	Triax BNC	41501B HPSMU	FORCE	DC FORCE	11612V K21
4	16494A Option 002	Triaxial cable	Triax BNC	41501B HPSMU	SENSE	DC SENSE	11612V K21
5	16493L Option 002	GNDU cable	Triax BNC	41501B	GNDU	GNDU	11612V K21
6	10833A	GPIB cable	GPIB	4156C	GPIB	GPIB	4284A
7	10833A	GPIB cable	GPIB	4284A	GPIB	GPIB	E8364B
8	10833A	GPIB cable	GPIB	E8364B	GPIB	GPIB	35670A
9	10833C	GPIB cable	GPIB	4156C	GPIB	GPIB	Controller

Figure 20 Rear Panel Wiring Diagram

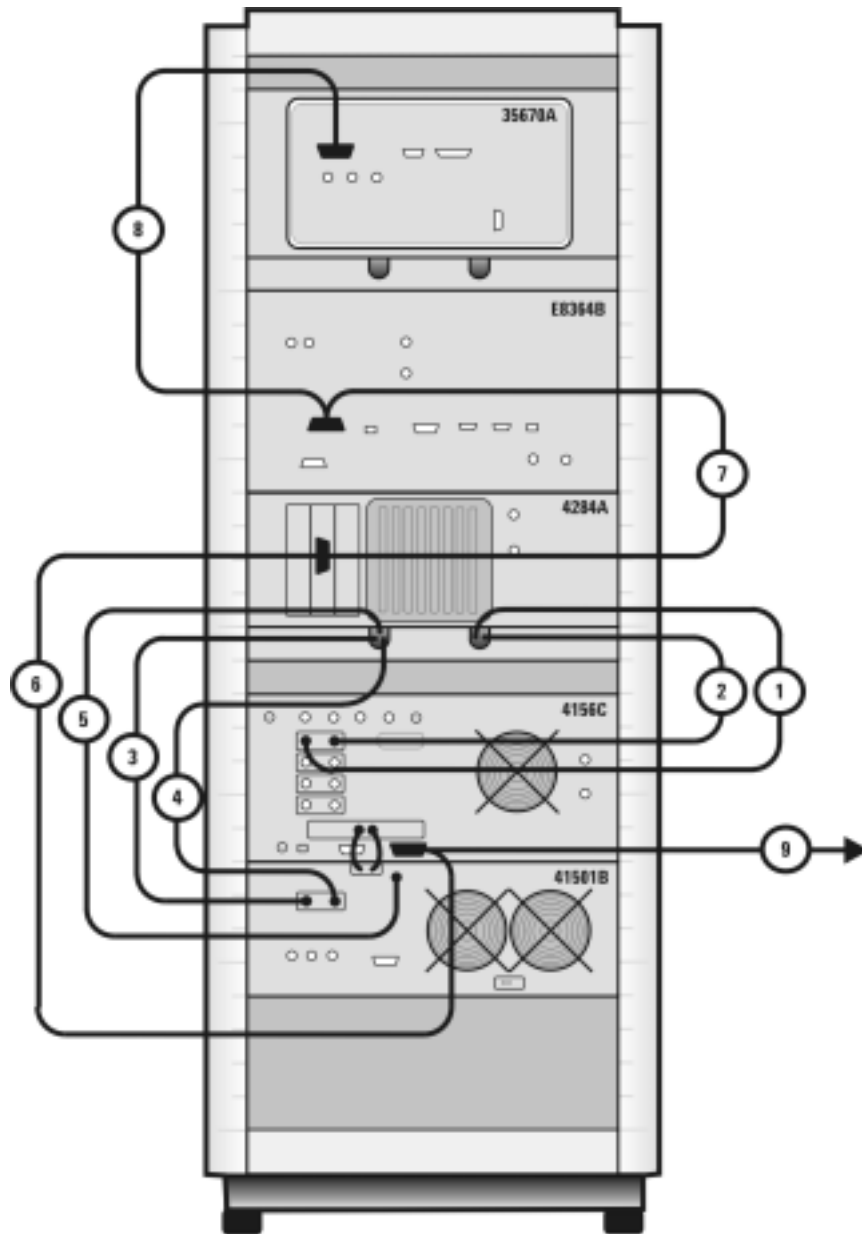

Figure 21 DC/RF Cabling Diagram - DC and RF Configuration

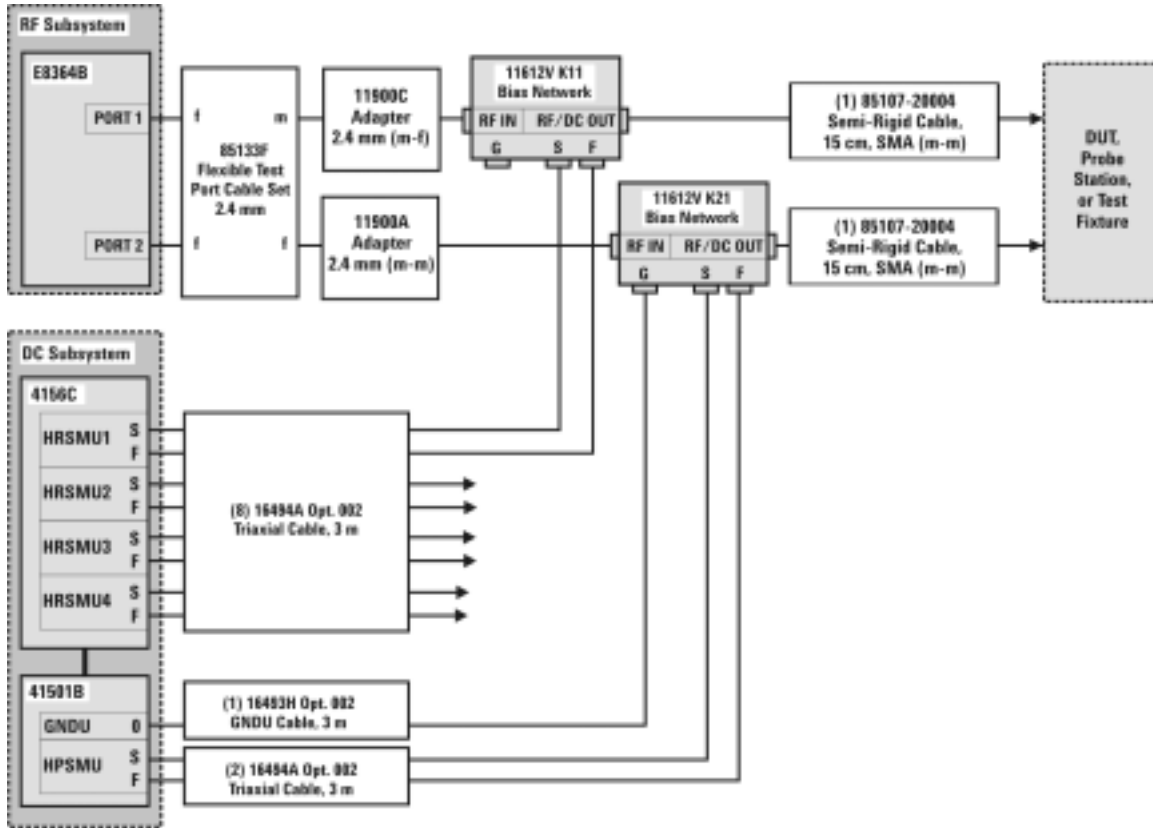
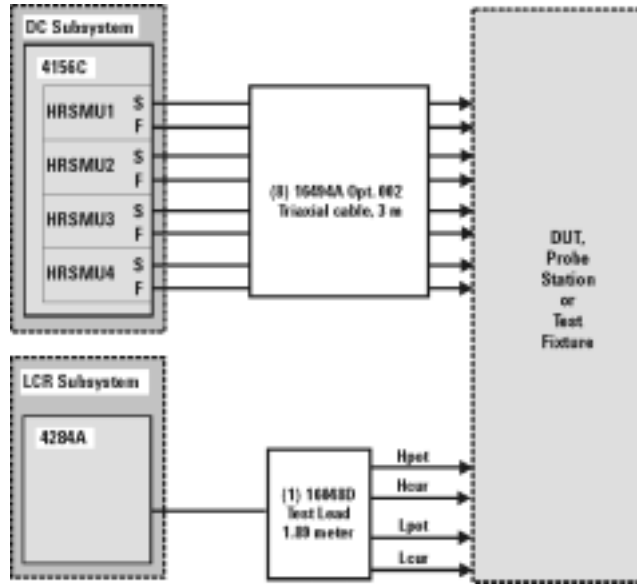

Figure 22 DC/RF Cabling Diagram - Parametric Configuration



Instrument Control Interface

Instrument control interface is provided by a General Purpose Interface Bus (GPIB) or LAN/GPIB gateway. GPIB addresses for programmable system components are listed in [Table 12](#).

Table 12 GPIB Addresses

Component	GPIB Address
Agilent 34401A digital multimeter	9
Agilent 35670A dynamic signal analyzer	10
Agilent 4156C precision semiconductor parameter analyzer	19*
Agilent 4284A precision LCR meter	24
Agilent E5810A LAN/GPIB gateway	21
Agilent E8364B PNA Series vector network analyzer	16
Agilent E5250A low leakage switch mainframe	22
Agilent E5260A 8-slot high speed parametric measurement mainframe	19
Agilent E5270B 8-slot precision parametric measurement mainframe	19

* The 4156C default GPIB address 17 is sometimes used by other devices with a GPIB address at 16 (for example, an external display (set to 17) to display the results generated by an instrument at address 16). Change the 4156C GPIB address to 19 using the procedure described in [step 13](#) of "To switch on power to the system" on page 87 to ensure that IC-CAP can recognize the 4156C.

The LAN/GPIB Gateway

The Agilent E5810A LAN/GPIB gateway provides access to the system's GPIB instrumentation over an existing local area network. It allows the use of SICL- or VISA-based applications designed for GPIB over the LAN without modifying the application beyond a simple address change.

The gateway is a combination of hardware and SICL/VISA software. It uses client/server technology to extend the standard remotely over the LAN, allowing remote control from an alternative, more convenient, or safer location.

Figure 23 Rear Panel Wiring Diagram for LAN/GPIB Gateway

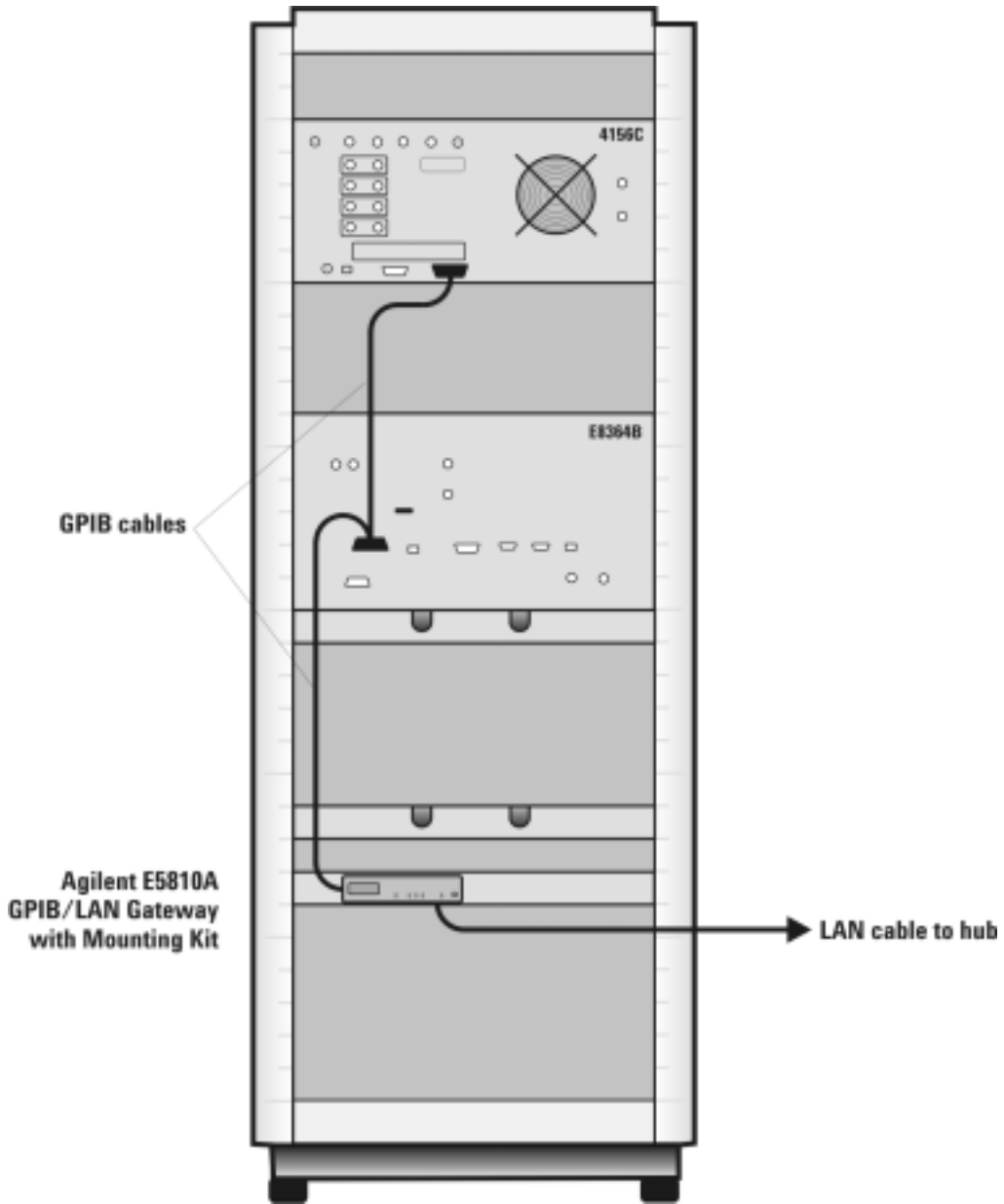

The System Controller

A customer-furnished UNIX workstation or personal computer running Agilent IC-CAP software controls the hardware via GPIB while making device measurements, then stores, simulates, and optimizes device parameters, using predefined or user-defined device models. [Table 13](#) on page 59 lists the personal computer requirements. [Table 14](#) on page 59 lists the UNIX workstation requirements.

Table 13 Personal Computer Requirements

Parameter	Requirement
Operating system	Microsoft Windows NT® 4.0-SP6a or Windows 2000 Professional-SP3.*
CPU	Intel Pentium® class 200 MHz CPU or higher
Display	Super VGA 800×600, 15 inch monitor (1024×728 recommended)
Hard disk space	370 MB. It is recommended that you install IC-CAP software on your local drive. Recommended file systems are FAT32 and NTFS. Novell file servers are not supported. <i>VFAT/FAT systems are not recommended for full installations.</i>
RAM	128 megabytes (additional RAM will improve software performance)
Virtual memory	300 megabytes† (Increased virtual memory may be required)

* Windows 95, 98, and ME are *not* supported.

† For NT 4.0 only: to avoid potential memory problems, ensure your virtual memory space is always greater than your RAM space.

Table 14 UNIX Workstation Requirements

Parameter	Requirement	
	HP UNIX Workstation	SunOS Workstation
Operating system	HP-UX 11.i with the following patches: PHSS_24627 HP aC++, AA Runtime Libraries (aCC A.03.33), PHSS_25718 LIBCL	SunOS 5.7, 5.8, and 5.9 (Solaris 7.0, 8.0, 9.0)
Window manager	HP VUE or CDE/X-Windows V.X11R5	Motif V.1.1/1.2 Open Windows 3.0, or CDE
RAM	128 megabytes (additional RAM will improve software performance)	
Swap space	200 megabytes (additional swap space will improve software performance)	
Hard disk	300 megabytes for minimum installation 500 megabytes for complete installation including online documentation and application examples	
Display	High resolution color only	

The Rack Cabinet

The system is housed in a 1.6 meter rack cabinet. The cabinet provides line power access, ventilation, mobility, and protection to the system instrumentation.

A rack-mounted work surface is included for maximum flexibility and convenience in making in-fixture or coaxial measurements. The work surface can be removed to facilitate on-wafer measurements using a probe station. The work surface is coated with antistatic material and connected to chassis ground. Therefore, an antistatic mat is not required. For installation instructions, see ["To install the work surface"](#) on page 74.

Performance Characteristics and Specifications

Supplemental characteristics are not specifications, but are provided in [Table 15](#) for your convenience.

Table 15 Supplemental System Characteristics

Characteristic	Value
Line voltage	115 volts nominal (90 volts to 132 volts) or 220 volts nominal (210 volts to 250 volts)
Line frequency	48 Hz to 66 Hz
Circuit breaker amperage rating	6 amps (115 volts), 3.5 amps (220 volts)
Rack weight capacity	818 kilograms (1800 pounds) maximum loaded
Rack external dimensions	1620 mm high × 600 mm wide × 905 mm deep

Rack footprint (top view)

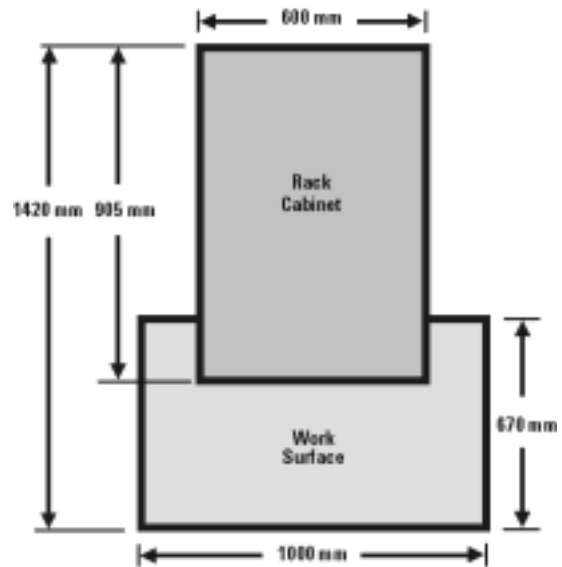

Interference Standards

The IEC/EN 61326-1 and CISPR Publication 11 standards define the RFI and EMI susceptibility of the performance modeling system.

Performance Modeling System Performance Specifications

The Agilent 85225F performance modeling system adheres to the performance specifications of an Agilent E8364B PNA Series vector network analyzer. Refer to [Appendix G](#), “Network Analyzer Performance Specification Summary,” starting on page 141.

RF Subsystem Performance Specifications

The overall performance of a network analyzer is dependent on the individual instruments, system configuration, user-defined operating conditions, measurement calibration, and cables.

For a specification summary, refer to [Appendix G](#), “Network Analyzer Performance Specification Summary,” starting on page 141.

In any high-frequency measurement, residual errors contribute uncertainties to the results.

NOTE

When the system is configured with a probe station, microwave probes, on-wafer calibration standards, or test fixtures, additional uncertainties are contributed to the measurement results. Refer to the manufacturer’s documentation for information on probe station or test fixture characteristics.

DC Subsystem Specifications

Specifications for the Agilent 4156C precision semiconductor parameter analyzer are listed in its user’s guide, chapter 7 of Volume 1, “General Information.”

Specifications for the Agilent E5260A 8-slot high speed measurement mainframe and Agilent E5270B 8-slot precision parametric measurement mainframe are listed in its user’s guide, Chapter 2, “Introduction.”

Bias Network Characteristics

[Table 20](#), “11612V Option K11/K21 Bias Network Characteristics,” on page 139 lists the operational characteristics of the bias networks. For detailed information, refer to [Appendix F](#), “Understanding the Bias Networks,” starting on page 137.



2 Installing the System

- To prepare the installation site [64](#)
- Environmental Requirements [64](#)
- Electrical Requirements [64](#)
- To receive the system [65](#)
- To unpack the shipment crate containing the rack cabinet [66](#)
- To verify the shipment [68](#)
- To install the work surface [74](#)
- To ensure your safety while using the system [76](#)
- Precautions for Performing Floating-Ground Measurements [78](#)
- Precautions for Avoiding Electrostatic Discharge [79](#)
- To connect the bias networks [80](#)
- To switch on power to the system [87](#)
- This completes the installation process. To confirm the functionality of the system, continue to Chapter 3, "Verifying System Functionality," starting on page 91. [89](#)

Related Topics

["Introducing the Agilent 85225F Performance Modeling System"](#) on page 17

Use this chapter to learn how to first prepare the installation site, and then receive, unpack, install, and configure the system. This chapter includes important information on operational safety, as well as instruction on preparing the installation site, unpacking the system, ensuring the completeness of the system shipment, installing the work surface, performing final system configuration, and powering-on the system.

To prepare the installation site

CAUTION

This product is designed for indoor use in Installation Category II and Pollution Degree 2 per IEC 61010-1 and 664 respectively.

Follow these steps to prepare the site for system installation.

To prepare the installation site

Step	Notes
1 Ensure that your installation site meets the environmental requirements.	<ul style="list-style-type: none"> Environmental requirements (temperature, relative humidity, altitude, and clearance) are listed in Table 16.
2 Ensure that your installation site meets the electrical requirements.	<ul style="list-style-type: none"> Electrical requirements are listed in Table 17.

Table 16 Environmental Requirements

Environmental Parameter	System Requirement
Temperature	+0°C to +45°C (+32°F to +113°F) ^{*†}
Relative humidity	Maximum 80% for temperatures up to 31°C decreasing linearly to 50% at 40°C
Altitude	Up to 3000 meters (approximately 10000 feet)
Clearance (behind and above rack) [‡]	15 centimeters (6 inches) minimum

* Install air conditioning and heating as needed to achieve the required ambient temperature range.

† Accuracy-enhanced measurement performance is specified at an ambient temperature range of +25°C ±5°C. After calibration, hold the ambient temperature of the measurement environment to ±1°C of the ambient temperature at the time of calibration.

‡ Required to ensure the extractor fans can properly ventilate the system.

Table 17 Electrical Requirements

Electrical Parameter	System Requirement
Supply capability	100/120 volts, 2000 VA 200/240 volts, 2000 VA
Circuit sharing	Do not connect air conditioning or motor-operated equipment to the same ac circuit supplying line voltage to the system.

To receive the system

Follow these steps to store, inspect, and confirm the system shipment.

To receive the system

Step	Action	Notes
1 Store and inspect the shipment.	<p>a Keep the shipping containers together, unopened, located in one area.</p> <p>b Inspect the shipping containers for damage.</p> <ul style="list-style-type: none"> • If the shipment is damaged, continue to step 2. • If the shipment is verified undamaged, continue to the next section, "To unpack the shipment crate containing the rack cabinet" on page 66. 	<ul style="list-style-type: none"> • Keep all cartons and packaging material until the entire shipment has been verified undamaged and complete, and the system has passed visual inspection and functional verification.
2 If the system is damaged, notify appropriate parties.	<p>a Report the shipment damage to your Agilent Technologies sales representative.</p> <p>b Report the shipment damage to the shipping carrier.</p> <p>c Provide all cartons and packaging material for inspection by the shipping carrier.</p>	<ul style="list-style-type: none"> • Agilent Technologies will repair or replace damaged equipment without waiting for a claim settlement from the shipping carrier.

To unpack the shipment crate containing the rack cabinet

The racked system is shipped upright secured to a pallet. Other system components are shipped separately. Follow these instructions to unpack and inspect the rack cabinet and the racked system components.

Required Tools

- 9/16 inch wrench or adjustable end wrench
- Prying tool to remove packaging clamps

WARNING

Always wear safety glasses when removing the clamps and other packing materials from the crate.

CAUTION

Be careful not to bend the clamps while removing them from the shipping crate. You may reuse the clamps when the system is repacked.

To unpack the shipment crate containing the rack cabinet

Step	Action	Notes
1 Remove the outer packing crate.	<p>a Remove the clamps holding the packing crate top cover in place.</p> <p>b Remove the top cover and set it aside.</p> <p>c Remove the clamps holding the first packing crate wall in place.</p> <p>d Insure that two other people are available to hold the last two walls in place as the last set of clamps is removed.</p> <p>e Remove the other walls.</p> <p>f Set the loading ramp panel aside for now.</p>	<ul style="list-style-type: none"> • Which wall is removed first does not matter. • In double-rack crates, the heaviest wall is the loading ramp. In single-rack crates, the loading ramp is shipped inside the crate, placed on top of the rack (it is a hinged assembly, shipped in the folded position).
2 Remove the packaging materials.	<p>a Remove the foam top cover.</p> <p>b Remove the plastic wrapping from the system.</p>	

To unpack the shipment crate containing the rack cabinet (continued)

Step	Action	Notes
3	<p>Unload the system</p> <ul style="list-style-type: none"> a Remove the two brace bolts attaching the side brace assembly to the bottom pallet. b Remove the side brace assembly. c Lift the hinged slat and remove the ramp anchor bolt. d Place one end of the ramp on the pallet ramp ledge. e Insert the ramp anchor bolt and fold down the hinged slat. f Fold down the ramp's end flap. 	<ul style="list-style-type: none"> • To secure the ramp, you may place long wood screws through the ramp and into the ramp ledge.

WARNING

A racked system is tall and top-heavy. It is easy to tip the rack over while moving it, which could result in injury or death. Unloading the system safely requires the participation of four persons exercising care so as not to topple the rack cabinet. Do not stand in front of the rack as it rolls down the ramp.

-
- g Ensure that the rack cabinet leveling feet are retracted and that the cabinet casters are rolling freely.
 - h Roll the system down the ramp using extreme care.
 - i Carefully roll the rack toward its prepared place within the measurement environment.
- In case the system must be moved in the future, retain and reuse these packing materials. You can also purchase replacement packing materials from Agilent Technologies.

To verify the shipment

Use [Table 18](#) “System Receiving Checklist and Replaceable Parts” to:

- confirm the completeness of the shipment
- provide component part and model numbers required to order replacement parts

All replacement items are available from Agilent Technologies. Part numbers for replacement instrument subassemblies are listed in their individual service manuals.

The majority of the system components are shipped preconfigured in the system rack cabinet.

The PGUs (pulse generator units) and GNDU (active ground unit) are factory-installed in the 41501B PGU expander.

With the exception of the bias networks, semi-rigid and SMU triaxial cables, all other cables are connected at the factory.

NOTE

Other cables and accessories are shipped inside the rack-mounted storage drawer.

To verify the shipment

Step	Action	Notes
1	Verify that the serial numbers on the rear panel of the system instruments match the serial numbers listed in the shipping documentation.	<p>Compare the serial numbers listed in the shipping documents with the serial numbers on the instrument’s rear panel serial number labels.</p> <ul style="list-style-type: none"> • If an instrument serial number does not match the shipping document, report mismatched serial number to your Agilent Technologies sales representative. • If all instrument serial numbers match the shipping documents, continue to step 2.

To verify the shipment (continued)

Step	Action	Notes
2	<p>Complete the receiving checklist.</p> <p>a Compare the Bill of Materials to the system components received in the shipment.</p> <p>b Verify the shipment is complete.</p> <ul style="list-style-type: none"> • If the shipment is confirmed incomplete, go to step 3. • If you have confirmed the presence of all system components, the receiving process is complete. Proceed to the next section "To ensure your safety while using the system" on page 76. 	<ul style="list-style-type: none"> • Refer to the Bill of Materials included with the shipment.
3	<p>If the system is incomplete, report missing items to your Agilent Technologies sales representative.</p>	<ul style="list-style-type: none"> • For a list of support contacts, see "To receive additional assistance" on page 107.

Table 18 Replaceable Parts

Part or Model Number	Description
10833A	GPIB cable, 1 meter
10833B	GPIB cable, 2 meter
10833C	GPIB cable, 4 meters
10833D	GPIB cable, 0.5 meter
11612T Option K33	Mounting plates, bias networks to probe station
11612V Option K11	Bias network, port 1, 45 MHz to 50 GHz, 0.5 A
11612V Option K21	Bias network, port 2, 45 MHz to 50 GHz, 0.5 A
11900A	Adapter, 2.4 mm (male-to-male)
11900B	Adapter, 2.4 mm (female-to-female)
11900C	Adapter, 2.4 mm (male-to-female)
1250-0080	Adapter, BNC, 50 ohm (female-female)
1250-1700	Adapter, coax
1250-2405C	Adapter, BNC coaxial tee
1250-3231	Adapter, triaxial BNC (female to male)
16048D	Test leads, 4 terminal pair, 1.98 meter
16493J Option 001	Interlock cable, 1.5 meter
16493L Option 001	GNDU cable, 1.5 meter

Table 18 Replaceable Parts (continued)

Part or Model Number	Description
16494A Option 001	Triaxial cable, 1.5 meter
16494A Option 002	Triaxial cable, 3 meter
16494B Option 001	Kelvin triaxial cable, 1.5 meter
16494B Option 002	Kelvin triaxial cable, 3 meter
34401A	Digital multimeter
35181M	Storage drawer
35670A	Dynamic signal analyzer
35670A Option AX4	Rack flange kit
35670A Option AY2	Two-input channel configuration
35670A Option AY6	Four-input channel configuration
35670A Option 1D4	Arbitrary source
41501B	SMU/PGU expander with GNDU and cable
41501B Option 410	Add 41501B with high power SMU and cables
41501B Option 412	Add high power SMU, 2 PGUs, and cables
41501B Option 420	Add 2 medium power SMUs and cables
41501B Option 422	Add 2 medium power SMUs, 2 PGUs, and cables
41501B Option 902	Cable, power, Europe
41501B Option 903	Cable, power, US and Canada
4156C	Precision semiconductor parameter analyzer
4156C Option 010	Delete all 4156C cables
4156C Option 020	Delete Windows controller for parameter analysis and characterization
4156C Option 200	1.5 meter interlock, 4 coaxial, 4 triaxial cables
4156C Option 230	3.0 meter interlock, 4 coaxial, 4 triaxial cables
4284A	Precision LCR meter
4284A Option 001	Add DC amplifier
4284A Option 006	Add 2 meter/4 meter cable operation
4284A Option 909	Rack mount kit
4284A Option ABA	English documentation
4284A Option ABJ	Japanese documentation
5063-9220	Rack mount kit with handles, 2-EIA

Table 18 Replaceable Parts (continued)

Part or Model Number	Description
5063-9221	Rack mount kit with handles, 3-EIA
5063-9222	Rack mount kit with handles, 4-EIA
5063-9223	Rack mount kit with handles, 5-EIA
5063-9224	Rack mount and handle kit, 6-EIA
5063-9225	Rack mount and handle kit, 7-EIA
8120-1396	Line power cord, 220V
8120-1839	Cable, BNC, 50 ohm, 24 inch
8120-1405	Line power cord, 120V
8120-1840	Cable, BNC, 48 inch
8120-2582	Cable
8120-5068	Cable
8490D Option 010	Attenuator, 2.4 mm coaxial, fixed 10 dB, DC to 50 GHz
85043-20001	Ground stud
85043-20002	Shoulder screw
85043-80013	Anti-static mat kit
85056A	Precision calibration kit, 2.4 mm
85056D	Economy calibration kit, 2.4 mm
85106-60038	Work surface, 1 meter
85107-20004	Semi-rigid cable, 9 inch, 2.4 mm (m-m)
85133F	2.4 mm flexible test port cable set
85225-90023	<i>Agilent 85225F Performance Modeling System Installation and User's Guide</i>
C2790AC	Ballast, 30 pounds
E3661B	Rack cabinet, 1.6 meter
E3661B Option AW3	Power distribution unit, 100/120 volts
E3661B Option AW5	Power distribution unit, 220/240 volts
E3663AC	Rail kit (2 rails per)
E3668B	Feedthrough panel
E4470AZ	Extractor fan, 100 to 120 volts
E4471AZ	Extractor fan, 200 to 240 volts
E5250A	Low leakage switch mainframe

Table 18 Replaceable Parts (continued)

Part or Model Number	Description
E5252A	10 x 12 switch matrix
E5260A	8-slot high speed parametric measurement mainframe
E5260A Option 050	50 Hz line power frequency
E5260A Option 060	60 Hz line power frequency
E5260A Option ABA	English documentation
E5260A Option ABJ	Japanese documentation
E5290A	High speed high power source monitor unit
E5291A	High speed medium power source monitor unit
E5270B	8-slot parametric measurement solution
E5270B Option 050	50 Hz line power frequency
E5270B Option 060	60 Hz line power frequency
E5270B Option ABA	English localization
E5270B Option ABJ	Japanese localization
E5280A	Precision high power source monitor unit
E5281A	Precision medium power source monitor unit
E5286A	High resolution source monitor unit
E5810A	LAN/GPIB gateway
E5810A Option 100	Rack mount kit
E5810A Option AG6	I/O libraries client software for MS Windows
E5810A Option ABJ	Japanese documentation
E7731A	Filler panel, 1-EIA unit
E7732A	Filler panel, 2-EIA unit
E7733A	Filler panel, 3-EIA unit
E7734A	Filler panel, 4-EIA unit
E7735A	Filler panel, 5-EIA unit
E7736A	Filler panel, 6-EIA unit
E7737A	Filler panel, 7-EIA unit
E8364B	PNA Series vector network analyzer, 10 MHz to 50 GHz
E8364B Option 010	Time domain analysis capability
E8364B Option 014	Configurable test set
E8364B Option 016	Receiver attenuators

Table 18 Replaceable Parts (continued)

Part or Model Number	Description
E8364B Option 022	Extended memory
E8364B Option 080	Frequency offset
E8364B Option 081	Reference receiver switch
E8364B Option 083	Frequency converter measurement application
E8364B Option 1CP	Rack mount kit with handles
E8364B Option H08	Pulsed RF measurement capability
E8364B Option H11	IF access
E8364B Option UNL	Extended power range

To install the work surface

If the system will not be used with a probe station, install the work surface to facilitate in-fixture or coaxial measurements.

The work surface is designed to fit onto the rack below the network analyzer. When the following procedure is performed properly, the work surface maintains a path to chassis ground through the support rails and the rack cabinet.

Follow these instructions to install the work surface.

Required Tools

- Medium Pozidriv screwdriver
- Small flat-blade screwdriver

To install the work surface

Step	Action	Notes
1 Prepare to install the work surface.	<p>a Fully extend the four lock feet at the bottom of the rack cabinet.</p> <p>b Unpack the work surface and the work surface support rails.</p> <p>c Lay the rails down so that:</p> <ul style="list-style-type: none"> • the ends with the single pemmed hole are facing the front, • the ends with the keyhole-shaped cutout are facing the rear, • and the rails are facing inward toward each other. 	<ul style="list-style-type: none"> • The lock feet prevent the cabinet from moving on the casters. • These are the positions of the support rails when installed in the rack.
2 Attach the support rails to the rack cabinet.	<p>a Pass the large end of the keyhole-shaped cutout in each rail over the shoulder screw already mounted inside the rack.</p> <p>b Slide the rails to the rear of the rack.</p> <p>c Use one 1/2 inch long 10-32 Pozidriv screw, one split lock washer, and one flat washer to secure each rail.</p> <p>d Before tightening the screws, ensure that the rails are level.</p> <p>e Tighten the screws.</p>	<ul style="list-style-type: none"> • You may need to hold the rails in place as you tightened the screws.

To install the work surface (continued)

Step	Action	Notes
3 Attach the work surface to the support rails.	<ul style="list-style-type: none"><li data-bbox="493 373 964 436">a Slide the work surface onto the support rails.<li data-bbox="493 443 964 527">b Slide the work surface all the way back on the rails until it comes to rest against the front of the rack cabinet.<li data-bbox="493 533 964 632">c Use 1/2 inch long 10-32 screws to secure the work surface to the rails from the beneath.	

To ensure your safety while using the system

This product has been designed and tested in accordance with international standards. Bias current and voltage are supplied to the DUT from the DC subsystem. This instrument can force dangerous voltages to the FORCE, SENSE, and GUARD connectors. DC subsystem is connected to the device through the bias networks and test fixture or probe station.

WARNING

Failure to comply with the following precautionary safety instructions prior to operating the system could result in serious injury or death.

With some installed options, the Agilent 4156C or Agilent E5260A/70B used in this system can supply voltages up to ± 200 volts DC. Depending on operating conditions, hazardous voltages can be present at points in the system that could potentially come in contact with the system operator.

Before operating the system, follow these steps to ensure your safety.

To ensure your safety while using the system

Step	Action	Notes
1	<p>Never operate the system without a safety earth ground.</p> <p>a Ensure that a safety earth ground is connected between the system power distribution unit and the line power source.</p> <p>b If it is likely that the safety earth ground has been impaired, the system must be rendered inoperative and secured against unintended operation.</p>	<ul style="list-style-type: none"> Capacitors within the system components can remain charged even after the system is disconnected from its line power source.
2	<p>Never attempt to service the system.</p> <p>a Contact Agilent Technologies if service is required.</p>	<ul style="list-style-type: none"> The system may only be serviced, adjusted, maintained, or repaired by qualified personnel.
3	<p>Open the DC subsystem interlock connection whenever possible.</p> <p>a Close the DC subsystem INTLK (Interlock) connection only when voltages greater than ± 42 volts DC are required.</p>	<ul style="list-style-type: none"> Depending on installed options, the SMU output can be as high as ± 200 volts DC. As long as the INTLK connection is open, the voltage is clamped to ± 42 volts DC maximum. For instruction on installing an interlock switch on a shielding box, see "To Make an Interlock Connection" in the 4156C user's guide (volume 1) or "Connecting the Interlock Terminal" in chapter 3 of the E5270 user's guide.

To ensure your safety while using the system (continued)

Step	Action	Notes
4 Be aware of potential shock hazards during floating-ground measurements.	<p>a Do not touch any of the DC subsystem output connectors when the shorting bar is disconnected and a floating-ground measurement is in progress.</p> <p>b Warn others working in the system's vicinity of the potential shock hazards.</p>	<ul style="list-style-type: none"> For additional information, see the following section “Precautions for Performing Floating-Ground Measurements.”
5 Before touching the FORCE, SENSE, or GUARD connectors, ensure your safety.	<p>a Switch off the DC subsystem and discharge the capacitors.</p> <p>b If you do not switch off the instruments, complete ALL of the following precautionary steps:</p> <ul style="list-style-type: none"> Terminate the DC subsystem measurement by pressing the Stop key and confirming that the MEASUREMENT indicator is not lit. Deactivate the standby mode (if used) by pressing the Standby key and confirming that the Standby indicator is not lit. Confirm that the HIGH VOLTAGE indicator is not lit. Open the interlock connection. 	
6 Never use replacement fuses with incorrect ratings.	<p>a After finding the cause of failure, replace component fuses with fuses of the same current rating and of the type specified in the instrument's product documentation.</p>	<ul style="list-style-type: none"> Failure to use correctly rated fuses could result in a fire hazard and damage to the equipment.
7 Install the instrument so that the ON/OFF switch is readily identifiable and easily reached by the operator.		<ul style="list-style-type: none"> The ON/OFF switch is the system disconnecting device. It disconnects the mains circuit from the mains supply before other parts of the instrument. Alternately, an externally installed switch or circuit breaker (readily identifiable and easily reached by the operator) may be used as a disconnection device.

Precautions for Performing Floating-Ground Measurements

IC-CAP measurements can be performed with the device in a floating-ground configuration. This prevents ground-loop noise and, in the case of a bipolar junction transistor, damage to the device under test.

A floating-ground configuration is created by removing the shorting bar that connects the CIRCUIT COMMON and CHASSIS GROUND terminals.

WARNING

A potential shock hazard exists when the shorting bar is disconnected for floating-ground measurements. Do not touch any of the DC subsystem rear panel connectors while a floating ground measurement is in progress.

If you are making measurements in a floating-ground configuration, *ensure that the shorting bar is disconnected* between the CIRCUIT COMMON and CHASSIS GROUND terminals.

To perform floating-ground measurements

When floating ground measurements are necessary, remove the rear front panel shorting bar connecting the CIRCUIT COMMON and CHASSIS GROUND terminals.

When the shorting bar is removed, you must drive the DUT circuit common with either an SMU, GNDU, or by connecting directly to the DC subsystem circuit common. The circuit common can be found at the DUT ends of the SMU and GNDU cables.

NOTE

The circuit common is not connected through the bias networks.

Read [“Precautions for Performing Floating-Ground Measurements”](#) on page 78, then follow these steps to connect the CIRCUIT COMMON to an external ground.

To connect an external ground to the circuit common

Step

- 1 Remove the shorting bar connecting the CIRCUIT COMMON and CHASSIS GROUND terminals.
 - 2 Connect the external ground to the CIRCUIT COMMON of the DC subsystem.
-

Precautions for Avoiding Electrostatic Discharge

Never operate the system without taking precautions to avoid electrostatic discharge that could damage the system or the device under test.

CAUTION

Even relatively small currents resulting from electrostatic discharge undetectable to the system operator can damage current-sensitive devices and system components.

To take precautions against electrostatic discharge

Step

- 1 Wear an antistatic wrist strap.
 - 2 Connect the wrist strap to chassis ground.
-

To connect the bias networks

Follow these steps to connect the bias networks to the system, and the device under test to the bias networks.

Agilent 4156C Systems

To connect the bias networks

Step	Action	Notes
1	For Agilent 4156C systems, refer to the following figure.	<p>The diagram illustrates the connection of a Network Analyzer to two bias networks. The Network Analyzer is connected to PORT 1 and PORT 2. The bias networks are connected to the Network Analyzer via 11900C and 11900A adapters. The bias networks are connected to the Network Analyzer via 11612V K11 and 11612V K21 bias networks. The bias networks are connected to the Network Analyzer via 11900C and 11900A adapters. The bias networks are connected to the Network Analyzer via 11612V K11 and 11612V K21 bias networks.</p>
2	Connect the triaxial cables from the 4156C to the bias networks.	<p>a Connect the triaxial cables from the 4156C HRSMU1 FORCE and SENSE connectors to the DC FORCE and DC SENSE connectors on the port 1 bias network.</p> <p>b Connect the triaxial cables from the 4156C HRSMU2 FORCE and SENSE connectors to the DC FORCE and DC SENSE connectors on the port 2 bias network.</p> <ul style="list-style-type: none"> From the rear of the system, route the cable through the feedthrough panel. The port 1 bias network is the 11612V K11. The port 2 bias network is the 11612V K21. Refer to Figure 5 on page 29.

To connect the bias networks (continued)

Step	Action	Notes
3	<p>Connect and route the triaxial cable from 4156C HRSMU3 FORCE connector to the port 2 bias network.</p> <p>a From the rear of the system, connect one end of the triaxial cable to the HRSMU3 FORCE connector on the 4156C rear panel.</p> <p>b From the rear of the system, route the cable through the upper feedthrough panel.</p> <p>c Connect the triaxial cable to the port 2 bias network GNDU connector.</p>	<ul style="list-style-type: none"> The triaxial cable model number is 16494A Option 002. Leave the GNDU connector on the port 1 bias network open.
4	<p>Connect the Agilent E8364B test ports to the bias networks.</p> <p>a Connect one end of the port 1 test port cable to the Agilent E8364B test port 1.</p> <p>b Connect the other end of the test port 1 test port cable to the 2.4 mm female-to-male adapter.</p> <p>c Connect the 2.4 mm female-to-male adapter to the RF IN connector on the 11612V Option K11 bias network.</p> <p>d Connect one end of the port 2 test port cable to the Agilent E8364B test port 2.</p> <p>e Connect the other end of the test port 2 test port cable to the 2.4 mm male-to-male adapter.</p> <p>f Connect the other end of the 2.4 mm male-to-male adapter to the RF IN connector of the 11612V K21 bias network.</p>	<ul style="list-style-type: none"> The test port cables model number is 85133F. The 2.4 mm female-to-male adapter model number is 11900C. Without this adapter, the test port cable will not properly mate with the bias network RF IN connector. The 2.4 mm male-to-male adapter model number is 11900A.
5	<p>Connect the bias networks to the device under test.</p> <p>a Connect one semi-rigid cable to the RF/DC OUT connector of the port 1 bias network.</p> <p>b Connect the other semi-rigid cable to the RF/DC OUT connector of the port 2 bias network.</p> <p>c Connect the device under test to the semi-rigid cable attached to the port 1 bias network.</p> <p>d Connect the device under test to the semi-rigid cable attached to the port 2 bias network.</p>	<ul style="list-style-type: none"> The semi-rigid cables part number is 85107-20004.

Agilent 4156C Systems with Agilent 41501B Expander Box

To connect the bias networks

Step	Action	Notes
------	--------	-------

1 For Agilent 4156C with 41501B expander box systems, refer to the following figure.

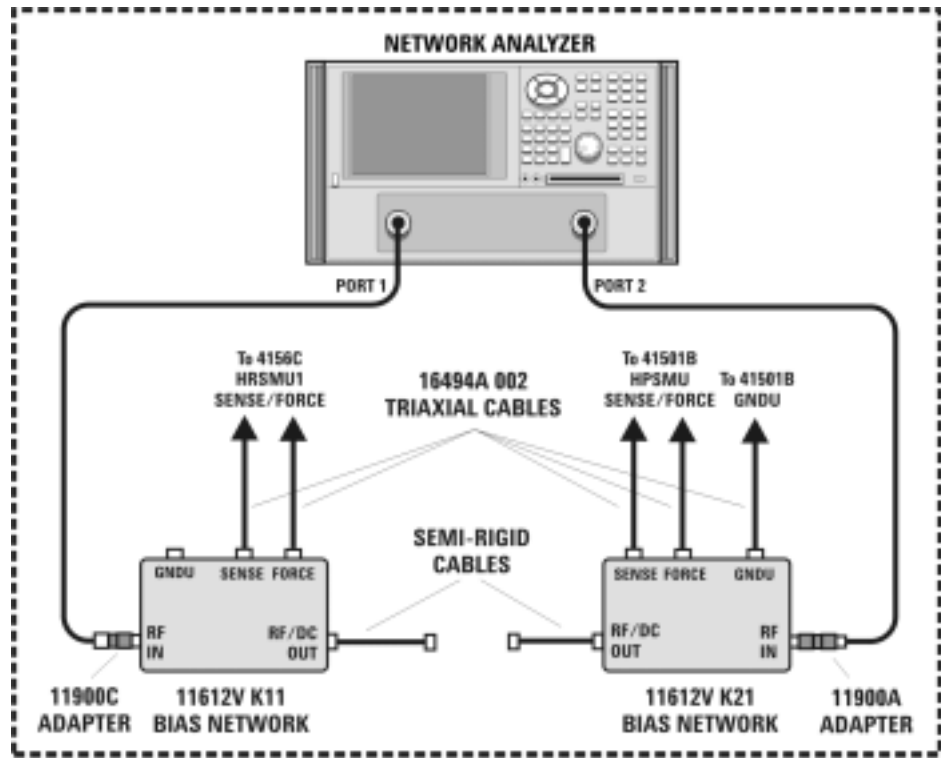

<p>2 Connect the triaxial cables from the 4156C to the bias networks.</p>	<p>a Connect the triaxial cables from the 4156C HRSMU1 FORCE and SENSE connectors to the DC FORCE and DC SENSE connectors on the port 1 bias network.</p> <p>b Connect the triaxial cables from the 41501B HPSMU FORCE and SENSE connectors to the DC FORCE and DC SENSE connectors on the port 2 bias network.</p>	<ul style="list-style-type: none"> From the rear of the system, route the cable through the feedthrough panel. The port 1 bias network is the 11612V K11. The port 2 bias network is the 11612V K21. Refer to Figure 20, "Rear Panel Wiring Diagram," on page 53.
<p>3 Connect and route the triaxial cable from 4156C HRSMU3 FORCE connector to the port 2 bias network.</p>	<p>a From the rear of the system, connect one end of the triaxial cable to the GNDU connector on the 41501B rear panel.</p> <p>b From the rear of the system, route the cable through the upper feedthrough panel.</p> <p>c Connect the triaxial cable to the port 2 bias network GNDU connector.</p>	<ul style="list-style-type: none"> The triaxial cable model number is 16494A Option 002. Leave the GNDU connector on the port 1 bias network open. Refer to Figure 3, "Front Panel Connections with Agilent 4156C," on page 25.

To connect the bias networks (continued)

Step	Action	Notes
4 Connect the Agilent E8364B test ports to the bias networks.	<p>a Connect one end of the port 1 test port cable to the Agilent E8364B test port 1.</p> <p>b Connect the other end of the test port 1 test port cable to the 2.4 mm female-to-male adapter.</p> <p>c Connect the 2.4 mm female-to-male adapter to the RF IN connector on the 11612V Option K11 bias network.</p> <p>d Connect one end of the port 2 test port cable to the Agilent E8364B test port 2.</p> <p>e Connect the other end of the test port 2 test port cable to the 2.4 mm male-to-male adapter.</p> <p>f Connect the other end of the 2.4 mm male-to-male adapter to the RF IN connector of the 11612V K21 bias network.</p>	<ul style="list-style-type: none"> • The test port cables model number is 85133F. • The 2.4 mm female-to-male adapter model number is 11900C. Without this adapter, the test port cable will not properly mate with the bias network RF IN connector. • The 2.4 mm male-to-male adapter model number is 11900A.
5 Connect the bias networks to the device under test.	<p>a Connect one semi-rigid cable to the RF/DC OUT connector of the port 1 bias network.</p> <p>b Connect the other semi-rigid cable to the RF/DC OUT connector of the port 2 bias network.</p> <p>c Connect the device under test to the semi-rigid cable attached to the port 1 bias network.</p> <p>d Connect the device under test to the semi-rigid cable attached to the port 2 bias network.</p>	<ul style="list-style-type: none"> • The semi-rigid cables part number is 85107-20004.

Agilent E5260A/70B Systems

To connect the bias networks

Step	Action	Notes
------	--------	-------

1 For Agilent E5260A/70B systems, refer to the following figure.

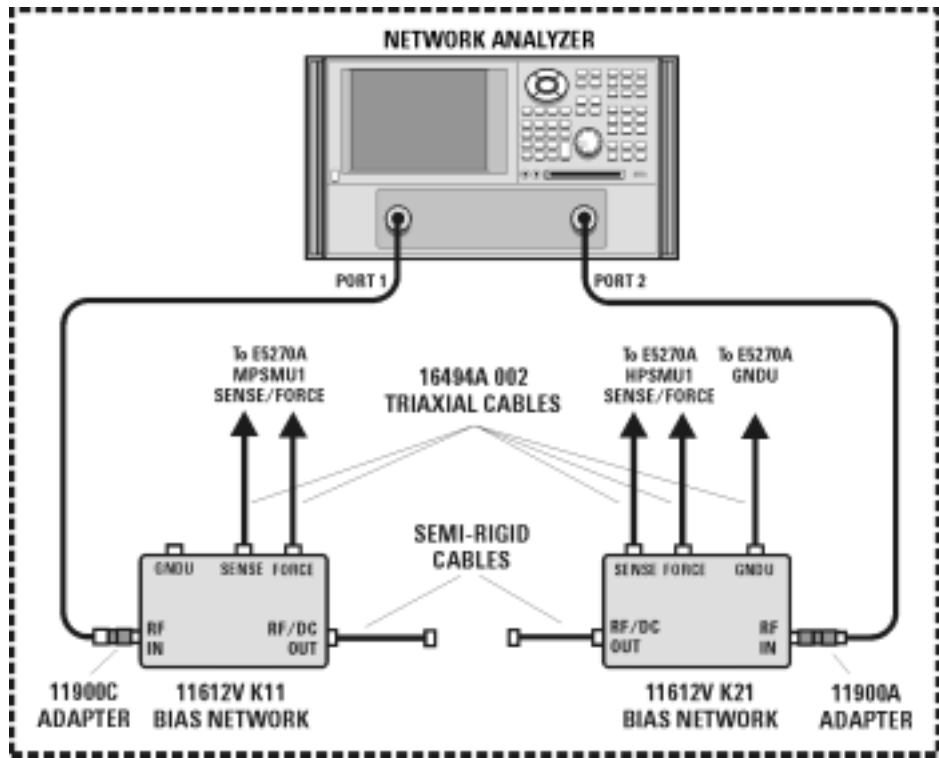

2 Connect the triaxial cables to the E5260A/70B SMUs.*

- From the front of the system rack, connect triaxial cables to the front panel high power SMU FORCE and SENSE outputs on the E5260A/70B.
 - Connect a triaxial cable to the front panel medium power SMU FORCE and SENSE outputs on the E5260A/70B.
 - From the front of the system, route the cable through the upper feedthrough panel.
 - From the rear of the system, route the HPSMU cable through the port 2 hole in the lower feedthrough panel.
 - From the rear of the system, route the MPSMU cable through the port 1 hole in the lower feedthrough panel.
- The triaxial cable model number is 16494A Option 002.
 - The high speed high power SMU is the Agilent E5290A.
 - The high speed medium power SMU is the Agilent E5291A.
 - The high power SMU is the Agilent E5280A.
 - The medium power SMU is the Agilent E5281A.
 - Refer to [Figure 4](#) on page 27

To connect the bias networks (continued)

Step	Action	Notes
3	<p>Connect the triaxial cables from the E5260A/70B SMUs to the bias networks.</p> <p>a Connect the triaxial cable from the E5260A/70B medium power SMU to the DC FORCE and DC SENSE connectors on the port 1 bias network.</p> <p>b Connect the triaxial cable from the E5260A/70B high power SMU to the DC FORCE and DC SENSE connectors on the port 2 bias network.</p>	<ul style="list-style-type: none"> The medium power SMU is the Agilent E5281A. The high power SMU is the Agilent E5280A. The port 1 bias network is the 11612V K11. The port 2 bias network is the 11612V K21.
4	<p>Connect and route the ground cable from E5260A/70B GNDU to the port 2 bias network.</p> <p>a From the front of the system, connect one end of the ground triaxial cable to the GNDU connector on the E5260A/70B front panel.</p> <p>b From the front of the system, route the cable through the upper feedthrough panel.</p> <p>c From the rear of the system, route the ground triaxial cable through the port 2 hole in the lower feedthrough panel.</p> <p>d Connect the ground triaxial cable to the port 2 bias network GNDU connector.</p>	<ul style="list-style-type: none"> The ground triaxial cable model number is 16493L Option 002. Leave the GNDU connector on the port 1 bias network open.
5	<p>Connect the Agilent E8364B test ports to the bias networks.</p> <p>a Connect one end of the port 1 test port cable to the Agilent E8364B test port 1.</p> <p>b Connect the other end of the test port 1 test port cable to the 2.4 mm female-to-male adapter.</p> <p>c Connect the 2.4 mm female-to-male adapter to the RF IN connector on the 11612V Option K11 bias network.</p> <p>d Connect one end of the port 2 test port cable to the Agilent E8364B test port 2.</p> <p>e Connect the other end of the test port 2 test port cable to the 2.4 mm male-to-male adapter.</p> <p>f Connect the other end of the 2.4 mm male-to-male adapter to the RF IN connector of the 11612V K21 bias network.</p>	<ul style="list-style-type: none"> The test port cables model number is 85133F. The 2.4 mm female-to-male adapter model number is 11900C. Without this adapter, the test port cable will not properly mate with the bias network RF IN connector. The 2.4 mm male-to-male adapter model number is 11900A.

2 Installing the System

To connect the bias networks (continued)

Step	Action	Notes
6	Connect the bias networks to the device under test. a Connect one semi-rigid cable to the RF/DC OUT connector of the port 1 bias network. b Connect the other semi-rigid cable to the RF/DC OUT connector of the port 2 bias network. c Connect the device under test to the semi-rigid cable attached to the port 1 bias network. d Connect the device under test to the semi-rigid cable attached to the port 2 bias network.	<ul style="list-style-type: none">• The semi-rigid cables part number is 85107-20004.



* Refer to [Figure 4](#), "Front Panel Wiring Diagram with Agilent E5260A or E5270B," on page 27.

To switch on power to the system

NOTE

Proper system operation is dependent on the sequence in which the system components are switched on.

To switch on power to the system

Step	Notes
1 Ensure that the individual instruments are configured to match the available line power source.*	<ul style="list-style-type: none"> For information regarding line power settings, refer to the individual instrument manuals.
2 Ensure that all component line power switches are set to the OFF position.	
3 Connect the system to line power.	
4 Switch the rack cabinet ~ Line switch from  to  (from standby to energized).	
5 Switch on the low leakage switch mainframe line power.	
6 Switch on the precision LCR meter line power.	
7 If present, on the 4284A SYSTEM CONFIG page, highlight the value in the GPIB ADDRESS field, and press 24 > Enter.	<ul style="list-style-type: none"> This sets the correct system GPIB address (24) for the 4284A.
8 If present, on the 35670A front panel, press Local/GPIB > ANALYZER ADDRESS > 22 > ENTER.	<ul style="list-style-type: none"> This sets the correct system GPIB address (22) for the 35670A.
9 If present, switch on the Agilent 4156C precision semiconductor parameter analyzer line power.	
10 If present, switch on the 41501B expander line power.	<ul style="list-style-type: none"> The expander must be switched on before the 4156C.
11 Switch on the Agilent 4156C precision semiconductor parameter analyzer line power.	<ul style="list-style-type: none"> Ensure that the 41501B has already been switched on prior to activating the 4156C.
12 On the 4156C, press System > [MISCELLANEOUS], move the pointer to the POWER LINE FREQUENCY field, and press [50 Hz] or [60 Hz].	<ul style="list-style-type: none"> This ensures that the 4156C is configured to match the available line power frequency. The value is set to 60 Hz at the factory. Use the front panel arrow keys to move the cursor.

2 Installing the System

To switch on power to the system

Step	Notes
13 On the 4156C, press System > [MISCELLANEOUS], highlight the 4156C value in the GPIB ADDRESS field, and press 19 > Enter.	<ul style="list-style-type: none">• This sets the correct system GPIB address (19) for the 4156C.
14 On the E5260A/70B, move the cursor to CONFIG, press Enter, move the cursor to ADDRESS, press Enter. Use the arrow keys to set the address to 19 and press Enter.	<ul style="list-style-type: none">• This sets the correct system GPIB address (19) for the E5260A/70B.
15 Switch on the Agilent E8364B PNA Series vector network analyzer line power.	
16 On the Agilent E8364B PNA Series vector network analyzer, from the Main dialog, select System > Configure > SICL/GPIB. In the SICL/GPIB dialog GPIB group box, select the Talker/Listener radio button and select 16 in the Address scroll list.	<ul style="list-style-type: none">• This sets the correct system GPIB address (16) for the E8364B.
17 If present, switch on the LAN/GPIB gateway line power.	Refer to the LAN/GPIB gateway documentation for instruction on installation and configuration.
18 Switch on the computer line power.	
19 Allow the system to warm up for one hour.	

* If the system is to be used with an autotransformer, ensure that the common terminal is connected to the neutral (grounded) side of the power source.

To configure the LAN/GPIB gateway for functional verification

If your system includes an Agilent E5810A LAN/GPIB gateway, follow these steps to configure the LAN/GPIB gateway in order to verify the functionality of the performance modeling system.

NOTE

This procedure explains how to configure IC-CAP to use the default LAN/GPIB gateway server IP address in order to verify the functionality of the performance modeling system.

After functional verification, contact your corporate IT professional and ask for a permanent server IP address assignment for the LAN/GPIB gateway. For instructions on changing the server IP address, see the LAN/GPIB gateway installation and configuration guide.

To configure the LAN/GPIB gateway

Step	Action	Notes
20 Start the IC-CAP software.*	<p>PC version:</p> <p>a Select Start > Programs > IC-CAP 2004 > IC-CAP.</p> <p>UNIX version:</p> <p>a Open a UNIX terminal window.</p> <p>b At the prompt, type <code>iccap</code>.</p> <p>c Press Enter.</p>	<ul style="list-style-type: none"> This starts IC-CAP and opens the IC-CAP/Status and IC-CAP/Main windows.
21 Add the interface to the IC-CAP Hardware Setup.	<p>a From the IC-CAP/Main window menu bar, choose Tools > Hardware Setup...[†]</p> <p>b Below the HP-IB Interface group box, click Add Interface.</p> <p>c In the Add HP-IB Interface dialog box, enter <code>lan[192.0.0.192]:hpib</code>.</p> <p>d Click OK.</p>	<ul style="list-style-type: none"> This opens the IC-CAP/Hardware Setup window. This opens the Add HP-IB dialog box. This configures the LAN/GPIB gateway (with its default server address) as the performance modeling system GPIB interface.

* To familiarize yourself with the IC-CAP software, refer to the first three chapters of the *Agilent IC-CAP 2004 User's Guide*, model number 85190D.

† If there is an existing IC-CAP interface (for example, **HP-IB**), select the existing interface and click **Delete Interface** before continuing to the next action.

This completes the installation process. To confirm the functionality of the system, continue to [Chapter 3](#), “Verifying System Functionality,” starting on page 91.

2 Installing the System



3 Verifying System Functionality

To choose a verification process 92

Understanding the System Functional Verification Test 94

Performing the System Functional Verification Test 95

Related Topics

["To enhance measurement accuracy"](#) on page 112

["Performing a Coaxial System Measurement Calibration"](#) on page 115

["Performing the DC Subsystem Functional Verification Test"](#) on page 121

["Performing the RF Subsystem Functional Verification Test"](#) on page 125

Use the procedures in this chapter to verify the functionality of the Agilent 85225F performance modeling system. This chapter includes procedures for choosing varying degrees of functional verification and performing the required post-installation system functional verification test.

To choose a verification process

System functionality can be verified using several different processes, depending on the level (system or subsystem) of functional verification required and the available tools.

The procedure provided in [“Performing the System Functional Verification Test”](#) on page 95 verifies that all of the system instruments interface correctly, and that the system can make software-driven measurements using a controller running the IC-CAP software.

Manual functional verification procedures for DC, RF, CV, and 1/f noise subsystem components can be found in:

- [Appendix B](#), “DC Subsystem Functional Verification Test,” starting on page 119
- [Appendix C](#), “RF Subsystem Functional Verification Test,” starting on page 123
- [Appendix D](#), “CV Subsystem Functional Verification Test,” starting on page 129
- [Appendix E](#), “1/f Noise Subsystem Functional Verification Test,” starting on page 133

NOTE

These tests do NOT verify that the system instrumentation conform to their individual performance specifications.

To verify the performance of the individual system components, complete the appropriate performance tests listed in their individual product documentation.

Follow these steps to choose a system functional verification process based upon your current situation.

To choose a system verification process

Situation	Action	Note
1 If the system has recently been installed or one of the DC or RF subsystem instruments has been replaced, and you have IC-CAP software...	Complete the steps listed in “Performing the System Functional Verification Test” on page 95.	<ul style="list-style-type: none"> • Completion of the System Functional Verification Test is required after system installation, or whenever an RF or DC subsystem component has been serviced or replaced. • The System Functional Verification Test verifies the functionality of instruments in the RF and DC subsystems. To verify the functionality of other system components, continue to the appropriate situation listed in this table.

To choose a system verification process (continued)

Situation	Action	Note
2 If you would like to manually check the functionality of the Agilent E8364B PNA Series vector network analyzer without using the GPIB interface...	Complete the steps listed in "Performing the RF Subsystem Functional Verification Test" on page 125.	
3 If you would like to manually check the functionality of the Agilent 4156C precision semiconductor parameter analyzer without using the GPIB interface...	Complete the steps listed in "Performing the DC Subsystem Functional Verification Test" on page 121.	
4 If you would like to manually check the functionality of the Agilent E5260A/70B without using the GPIB interface...	Complete the steps listed in "Performing the DC Subsystem Functional Verification Test" on page 121.	
5 If you would like to manually check the functionality of the Agilent 4284A without using the GPIB interface...	Complete the steps listed in "Performing the CV Subsystem Functional Verification Test" on page 131.	
6 If you would like to manually check the functionality of the Agilent 35670A without using the GPIB interface...	Complete the steps listed in "Performing the 1/f Noise Subsystem Functional Verification Test" on page 135.	
7 If you would like to manually check the functionality of the Agilent E5250 low leakage switch mainframe without using the GPIB interface...	Complete the Agilent E5250A self-test found in Chapter 3 of the low leakage switch mainframe user's guide.	

Understanding the System Functional Verification Test

The system functional verification test is a standard IC-CAP measurement and simulation procedure. The system performs DC and S-parameter extraction, optimization, and simulation using a fixed 10 dB attenuator as the device under test (DUT).

The procedure provided in [“Performing the System Functional Verification Test”](#) confirms:

- the IC-CAP software can communicate with and control the system instrumentation via GPIB (through the LAN/GPIB gateway, if so configured)
- the system can make measurements and display the results
- the IC-CAP software can simulate data
- the IC-CAP software can converge the simulated data with the extracted (measured) data

The system applies forward and reverse current to the attenuator and monitors voltage at the attenuator’s input and output. IC-CAP then uses the measured data to model the device-intrinsic resistances and transmission line delay.

Required Tools

- Agilent 85225F performance modeling system
- A system controller^{*}
- Agilent 85190A IC-CAP software
- Test port cables
- Agilent 8490D 10 dB fixed RF attenuator[†]
- BNC tee (2)[‡]
- Agilent 11900A, 2.4 mm male-to-male adapter
- Agilent 11900B, 2.4 mm female-to-female adapter
- Agilent 11900C, 2.4 mm female-to-male adapter
- Agilent 85056A 2.4 mm precision calibration kit, or
- Agilent 85056D 2.4 mm economy calibration kit

^{*} For requirements, see [“The System Controller”](#) on page 59.

[†] These components are supplied as part of the system.

[‡] For CV subsystem verification only

Performing the System Functional Verification Test

Complete the following steps to verify system functionality using the supplied Agilent 8490D 10 dB fixed RF attenuator as the device under test.

To perform the system functional verification test

Step	Action	Notes
1	Switch on power to the system.	<p>a Complete the steps listed in "To switch on power to the system" on page 87.</p> <ul style="list-style-type: none"> Proper system function is dependent upon the order in which the system components are switched on.

- 2 Connect the device under test to the bias networks.
- a Refer to the following figure.

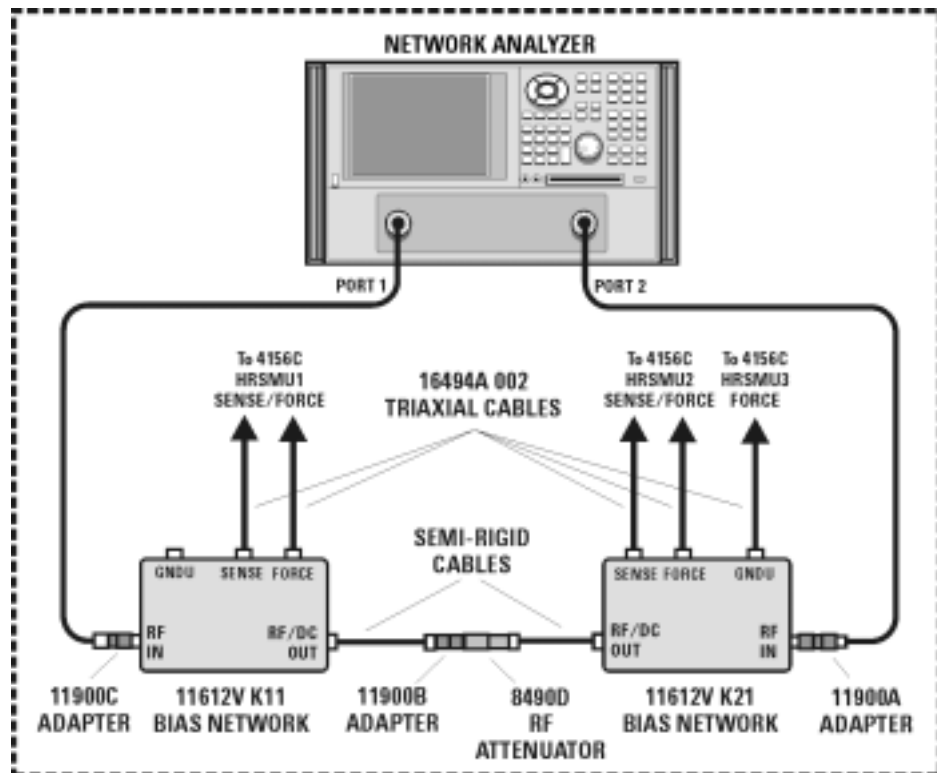

- b Connect one end of the 2.4 mm female-to-female adapter to the semi-rigid cable attached to the RF/DC OUT connector of the port 1 bias network.
- c Connect male end of the attenuator to the other end of the 2.4 mm female-to-female adapter.
- d Connect the female end of the attenuator to the semi-rigid cable attached to the RF/DC OUT connector of the port 2 bias network.
- The 2.4 mm female-to-female adapter is a 11900B. Use the 11900B provided in the calibration kit.
 - The port 1 bias network is a 11612V K11.
 - The port 2 bias network is a 11612V K21.

3 Verifying System Functionality

To perform the system functional verification test (continued)

Step	Action	Notes
3 Start the IC-CAP software.*	<p>PC version:</p> <p>a Select Start > Programs > IC-CAP 2004 > IC-CAP.</p> <p>UNIX version:</p> <p>a Open a UNIX terminal window.</p> <p>b At the prompt, type <code>iccap</code>.</p> <p>c Press Enter.</p>	<ul style="list-style-type: none"> This starts IC-CAP and opens the IC-CAP/Status and IC-CAP/Main windows.
4 Add the system interface and components to the IC-CAP Hardware Setup.	<p>a From the IC-CAP/Main window menu bar, choose Tools > Hardware Setup...</p> <p>b If you have not added an interface, click Add Interface, enter the system interface (<code>hpib</code> or other), and click OK.</p> <p>c In the Instrument List, click Rebuild.</p> <p>d Verify that all system components appear in the Instrument List.</p>	<ul style="list-style-type: none"> This opens the IC-CAP/Hardware Setup window. This polls the GPIB and adds all connected and activated system instruments to the Instrument List. Disregard error messages on the system instrument displays. The errors are a by-product of the GPIB polling process.
5 For 4156C systems, change the Agilent 4156C precision semiconductor parameter analyzer HRSMU names in IC-CAP.	<p>a In the Instrument List, select HP4156 (hpib, 19) and click Configure...</p> <p>b In the Configuration of HP4156 window Unit Table group box, highlight the characters in the HRSMU1 entry box and type <code>VG</code>.</p> <p>c In the Unit Table group box, highlight the characters in the HPSMU entry box and type <code>VD</code>.</p> <p>d Click OK.[†]</p> <p>e Close the Hardware Setup window.</p>	<ul style="list-style-type: none"> This opens the Configuration of HP4156 window where the Unit Table dialog box is used to change the names of the HRSMUs. Actions <i>b</i>, <i>c</i>, and <i>d</i> change the name of HRSMU1 to VG and HPSMU to VD. Renaming the SMUs is necessary for proper execution of the example model file.
6 For E5260A/70B systems, change the Agilent 4156C precision semiconductor parameter analyzer SMU names in IC-CAP.	<p>a In the Instrument List, select Agilent E5270 (hpib, 19) and click Configure...</p> <p>b In the Configuration of E5270 window Unit Table group box, highlight the characters in the MPSMU<slot number> entry box and type <code>VG</code>.</p> <p>c In the Unit Table group box, highlight the characters in the HPSMU<slot number> entry box and type <code>VD</code>.</p> <p>d Click OK.[‡]</p> <p>e Close the Hardware Setup window.</p>	<ul style="list-style-type: none"> This opens the Configuration of E5270 window where the Unit Table dialog box is used to change the names of the SMUs. Actions <i>b</i>, <i>c</i>, and <i>d</i> change the name of MPSMU<slot number> to VG and HPSMU<slot number> to VD. Renaming the SMUs is necessary for proper execution of the example model file.

To perform the system functional verification test (continued)

Step	Action	Notes
7	<p>Open the attenuator test model in IC-CAP.</p> <p>a From the IC-CAP/Main window menu bar, choose File > Examples...</p> <p>b In the Directories list of the File Open dialog box, double-click on the directory .../examples/model_files.</p> <p>c In the Directories list of the File Open dialog box, double-click on the directory .../model_files/misc.</p> <p>d In the Files list of the File Open dialog, double-click on sys_testrf.mdl.</p>	<ul style="list-style-type: none"> This opens the File Open dialog box. This opens a list of model files. (Scroll the list, if needed.) This displays a list of modeling files in the Files list of the File Open dialog. This opens the Atten model window. The Atten model window contains tab folders used to interact with the model data.
8	<p>Set the model variables for the measurement in IC-CAP.</p> <p>a Click the Model Variables tab folder.</p> <p>b Highlight the freq_start variable and enter 4.5E+07.</p> <p>c Highlight the freq_stop variable and enter 50E+09.</p> <p>d Highlight the imax variable and enter 90m.</p>	<ul style="list-style-type: none"> This opens the Model Variables tab folder. This sets the start frequency of the model to 45 MHz. This sets the stop frequency of the model to 50 GHz. This sets the maximum current to 90 milliamps.
9	<p>Set the network analyzer instrument options for the attenuator test model in IC-CAP.</p> <p>a In the DUTs-Setups tab folder, click S_vs_freq in the Select DUT/Setup list.</p> <p>b Click the Instrument Options tab folder.</p> <p>c Highlight the Cal Type value and enter H.</p> <p>d Highlight the Cal File Name value and enter TEST.CST.</p>	<ul style="list-style-type: none"> This opens the 5 tab folders used for the S_vs_freq setup. This opens the Instrument Options tab folder. Adjustable instrument parameters are listed in group boxes titled as <i>instrument model number.bus address.instrument address</i> (for example, <i>AgilentPNA.7.16</i> for the network analyzer group box). Terminate your value entries by pressing Enter on the controller keyboard.

3 Verifying System Functionality

To perform the system functional verification test (continued)

Step	Action	Notes
10	<p>Configure the instrument state for calibration.</p> <p>a Disconnect the attenuator from the semi-rigid cables.</p> <p>b In the Utility key group on the network analyzer front panel, press Macro/Local > Preset.</p> <p>c In the Channel menu, click Power...</p> <p>d In the Power dialog box, scroll the Test Port Power value to -20 dBm, then click OK.</p> <p>e In the Sweep menu, point to Number of Points and click 101.</p> <p>f In the Sweep menu, select IF Bandwidth...</p> <p>g In the IF Bandwidth dialog box, scroll to 1.000 kHz, then click OK.</p> <p>h In the Sweep menu, select Sweep Setup...</p> <p>i In the Sweep Setup dialog box, select the Stepped Sweep check box and click OK.</p>	<ul style="list-style-type: none"> This removes the instrument from GPIB control, activates the front panel interface, and returns the instrument to its factory preset condition. Actions <i>c</i> through <i>h</i> prepare the network analyzer for a full range 2-port calibration using the same instrument state settings used by the IC-CAP functional verification test macro.
11	<p>Calibrate the network analyzer.</p> <p>a In the network analyzer's Calibration menu, select Calibration Wizard...</p> <p>b In the Calibration Wizard: Begin Calibration dialog box, select SmartCal (GUIDED Calibration): Use Mechanical Standards radio button and click Next.</p> <p>c Follow the displayed prompts to calibrate the network analyzer.</p>	<ul style="list-style-type: none"> For detailed instructions, see "Performing a Coaxial System Measurement Calibration" on page 115. This begins a modified full 2-port calibration. When prompted to connect a standard to either Port 1 or Port 2, connect the standard to the semi-rigid cable attached to the Port 1 or Port 2 bias network. An isolation calibration is not needed for this measurement.
12	<p>Save the calibration and instrument state data to the <i>C:/Program Files/Agilent/Network Analyzer/Documents</i> folder.</p> <p>a In the File menu, select Save As...</p> <p>b In the Save As dialog box, using the keyboard or by clicking Edit File Name, enter <code>TEST.CST</code> then click OK.</p>	<ul style="list-style-type: none"> This saves the calibration and instrument state data in the network analyzer's operating system <i>C:/Program Files/Agilent/Network Analyzer/Documents</i> folder.

To perform the system functional verification test (continued)

Step	Action	Notes
13 Make the DC and RF measurements in IC-CAP.	<p>a Reconnect the attenuator.</p> <p>b In the Atten model window, click the Macros tab.</p> <p>c In the Select Macro: list, select Test_atten and click Execute.</p> <p>d When prompted to ensure you have calibrated the network analyzer, enter Y and click OK.</p> <p>e When prompted to enter a cal set number use the default (1) and click OK.</p> <p>f As IC-CAP performs an optimization, observe the simulated data trace converge with the measured data trace.</p>	<ul style="list-style-type: none"> • This opens the Atten model window's Macros tab folder. • This starts a sequence of prompts and responses. • IC-CAP performs measurements of the attenuator's DC and RF parameters. • When complete, IC-CAP displays plots of the forward and reverse DC voltage transfer through the attenuator. The solid line is the measured data, the dashed line is the simulated data. • IC-CAP begins the optimization process using default simulated data. These values are optimized to converge with the measured data.
14 Interpret the results.	<p>a Observe the displayed plots.</p> <p>b In the IC-CAP/Status window, observe the final DC/RF values parameter and the Final RMS error.</p>	<ul style="list-style-type: none"> • When the S-parameter measurement is complete, IC-CAP displays plots of the S12/21, $20 \times \log_{10}$ of the S21 magnitude, and S21 phase.** • IC-CAP also lists the attenuator's resistance values. The error between measured and simulated data should be less than 2%. • The error between the measured and simulated S21 phase data should be less than 2%. • The value for T1.TD is the transmission time through the attenuator, modeled as transmission line delay. This value (typically in the femtosecond to nanosecond range) depends on the length of the attenuator. • The S21 magnitude and the S12/S21 plots, of less significance, are included for your interest. • The S21 simulated trace is determined from the measured DC resistances, and therefore is not expected to converge with the measured data over the full frequency range. However, the measured S21 data will show a normal frequency response variation. • The S12/S21 plot (also displayed on the network analyzer) confirms that the system is capable of making forward and reverse transmission measurements.

3 Verifying System Functionality

To perform the system functional verification test (continued)

Step	Action	Notes
15 For systems with the Agilent 4284A precision LCR meter, open the junction capacitance model (juncap.mdl) in IC-CAP.	<p>a From the IC-CAP/Main window menu bar, choose File > Examples...</p> <p>b In the Directories list of the File Open dialog box, double-click on the directory .../examples/model_files.</p> <p>c In the Directories list of the File Open dialog box, double-click on the directory .../model_files/diode.</p> <p>d In the Files list of the File Open dialog, double-click on juncap.mdl.</p>	<ul style="list-style-type: none"> • This opens the File Open dialog box. • This opens a list of model files. • (Scroll the list, if needed.) This displays a list of modeling files in the Files list of the File Open dialog. • This opens the juncap model window. • The juncap model window contains tab folders used to interact with the model data.
16 Select the DUT/Setup.	<p>a Select the DUTs-Setups tab.</p> <p>b Click the area > cv setup.</p>	<ul style="list-style-type: none"> • This opens the capacitance vs. voltage setup.
17 Set the LCR meter instrument options.	<p>a Select the Instrument Options tab.</p> <p>b Highlight the Cable Length variable and enter 2.</p>	<ul style="list-style-type: none"> • This sets the cable length in the LCR meter instrument options.
18 Calibrate the LCR meter.	<p>a On the 16048D test leads, connect one tee between the H_{pot} and H_{cur} connectors.</p> <p>b Connect the other tee between the L_{pot} and L_{cur} connectors. Select the Measure/Simulate tab.</p> <p>c Select Calibrate.</p> <p>d Follow the IC-CAP prompts.</p>	<ul style="list-style-type: none"> • This performs a calibration on the LCR meter. • The BNC tee part number is 1250-2405.
19 Measure the open circuit capacitance.	<p>a Select Measure.</p>	<ul style="list-style-type: none"> • This measures the open circuit capacitance.
20 Observe the results	<p>a After the calibration is complete, observe the plot.</p> <p>b Rescale the measured result (displayed in red) cap.m.</p>	<ul style="list-style-type: none"> • The measured result should be less than $\pm 10E-15$ farads.

* To familiarize yourself with the IC-CAP software, refer to the first three chapters of the *Agilent IC-CAP 2004 User's Guide*, model number 85190D.

† To save this hardware configuration: on the IC-CAP main menu bar, choose **File > Save As** and enter a filename, for example `config1.hwd` (the file suffix must be `.hwd`).

‡ To save this hardware configuration: on the IC-CAP main menu bar, choose **File > Save As** and enter a filename, for example `config1.hwd` (the file suffix must be `.hwd`).

**S12 is identical to S21 because the attenuator is assumed to be symmetrical.

This completes the functional verification procedure.

If you encounter a problem

- ✓ Check the system connections and settings:
 - 1 system connections to the DUT
 - 2 system interconnections
 - 3 GPIB cabling
 - 4 GPIB address settings
- ✓ Perform the DC subsystem self-test in [Appendix B](#), “DC Subsystem Functional Verification Test,” starting on page 119.
- ✓ Perform the Agilent E8364B PNA Series vector network analyzer operator’s check in [Appendix C](#), “RF Subsystem Functional Verification Test,” starting on page 123.
- ✓ Perform the Agilent 4284A precision LCR meter self-test in [Appendix D](#), “CV Subsystem Functional Verification Test,” starting on page 129.
- ✓ Perform the Agilent 35670A dynamic signal generator self-test in [Appendix E](#), “1/f Noise Subsystem Functional Verification Test,” starting on page 133.

3 Verifying System Functionality



4 Servicing the System

- To troubleshoot the system [104](#)
- To remove or replace a system component [105](#)
- To order replacement parts [106](#)
- To receive additional assistance [107](#)
- Contacting Agilent Technologies [107](#)
- To package the system for transport [108](#)

Related Topics

- ["Performing the System Functional Verification Test"](#) on page 95
- ["Component Integration"](#) on page 48

Use this chapter to solve problems. This chapter includes a checklist for troubleshooting the system, a procedure for removing a system component from the rack cabinet, information on ordering replacement parts and acquiring additional assistance to solve your measurement problem.

To troubleshoot the system

Most system problems are caused by faulty cabling or switch configurations.

Refer to [Figure 20](#) on page 53 and [Figure 19](#) on page 51 and do the following:

- ✓ Check system connections and settings:
 - 1 system connections to the DUT
 - 2 system interconnections
 - 3 GPIB cabling
 - 4 GPIB address settings

If the cabling and switch configurations are verified correct, do the following:

- ✓ Complete the Agilent E8364B PNA Series vector network analyzer operator's check in "[Performing the RF Subsystem Functional Verification Test](#)" on page 125.
- ✓ Complete the Agilent 4156C precision semiconductor parameter analyzer self-test in "[Performing the DC Subsystem Functional Verification Test](#)" on page 121.
- ✓ Complete the Agilent 4284A self-test by cycling the instrument's line power. If errors occur, refer to Appendix B in the precision LCR meter operation manual. The operation manual is included in with the Agilent 85225F performance modeling system.
- ✓ If you suspect trouble with the E2050B, see "Chapter 4 Troubleshooting" in the E5810A LAN/GPIB gateway installation and configuration guide.
- ✓ Complete the Agilent E5250A self-test and leak test found in Chapter 3 of the low leakage switch mainframe user's guide. The user's guide is included with the Agilent 85225F performance modeling system.

If a problem with one of the system components is found, refer to the troubleshooting and repair information in the individual instrument's product documentation.

For more information, see "[To receive additional assistance](#)" on page 107.

To remove or replace a system component

Follow these steps to remove a system component for periodic component calibration, service, or repair.

WARNING

These servicing instructions are provided for use by qualified personnel only. To avoid electrical shock, do not perform any servicing unless you are qualified to do so.

WARNING

The opening of covers or removal of parts is likely to expose dangerous voltages. Disconnect the product from all voltage sources before opening covers or removing parts.

To remove a system component

Step	Note
1 Turn off all components.	
2 Disconnect the system from line power.	
3 Disconnect all cables from the instrument to be removed.	
4 Prepare a surface near the rack cabinet to place the removed system component.	
5 Lower the stabilizing legs on the rack cabinet.	
6 From the front of the rack cabinet, remove the four screws (2 screws on each rack mount) attaching the instrument's rack mount and handle kit to the rack cabinet.	
7 As another person steadies the rack cabinet, hold the instrument by the rack mount handles and slowly pull forward.	<ul style="list-style-type: none"> Some components may weigh more than 50 pounds and may require more than one person to remove safely.
8 Save the rack mount screws by reinserting them in the rack cabinet frame nuts.	

Follow the steps in reverse order to replace a system component.

Following the replacement of a system component, complete the procedure in “[Performing the System Functional Verification Test](#)” on page 95.

To order replacement parts

To find the part or model number of a replaceable system component, refer to [Table 18](#), “Replaceable Parts,” on page 69.

To order, contact Agilent Technologies by calling the telephone number listed in [Table 19](#) on page 107 appropriate to the location of the modeling system.

To receive additional assistance

If you would like assistance, visit the online assistance web site, or call the telephone number listed in [Table 19](#) appropriate to the location of modeling system.

Table 19 Contacting Agilent Technologies

Online assistance: <http://eesof.tm.agilent.com/support/>

Australia (tel) 1 800 629 485 (fax) (+61) 3 9210 5947	Canada (tel) 1 877 894 4414 (fax) (905) 282-6495	Europe (tel) (+31) 20 547 2323 (fax) (+31) 20 547 2390	Hong Kong (tel) 800 930 871 (fax) (852) 2506 9233
India (tel) 1 600 11 2929 (fax) 000 800 650 1101	Japan (tel) (+81) 426 56 7832 (fax) (+81) 426 56 7840	Latin America (tel) (305) 269 7500 (fax) (305) 269 7599	Malaysia (tel) 1 800 828 848 (fax) 1 800 801
New Zealand (tel) 0 800 738 378 (fax) (+64) 4 495 8950	People's Republic of China (tel) 800 810 0189 (preferred) (tel) 10800 650 0021 (fax) 110800 650 0121	Philippines (tel) (632) 8426802 (fax) (632) 8426809	Philippines (PLDT Subscriber Only) (tel) 1 800 16510170 (fax) 1 800 16510288
Singapore (tel) 1 800 375 8100 (fax) (65) 836 0252	Taiwan (tel) 0800 047 866 (fax) (886) 2 25456723	Thailand (tel) (088) 226 008 (outside Bangkok) (tel) (662) 661 3999 (within Bangkok) (fax) 1 661 3714	United States (tel) 1 800 829 4444

To package the system for transport

Follow these instruction to package the system in a shipping crate.

To package the system for transport

Step	Note
1	Place the packaging base in an unobstructed work area.
2	Remove the lag bolt from one side of the retaining piece.
3	Swing unbolted end of retaining piece outward.
4	Attach loading ramp.
5	Roll rack cabinet up ramp face first until it is fully seated on base.
6	Remove ramp.
7	Swing retaining piece back to original position.
8	Secure retaining piece with bolt.
9	Secure rack cabinet to base using retaining brackets inserted in the slot located on each side of the packaging base.
10	Secure retaining brackets with bolt and tighten.
11	Place antistatic bag over rack cabinet.
12	Place cardboard/foam top cap on top of rack cabinet.
13	Place folded ramp on top cap.
14	Place crate side panel and crate front panel on to base (the side panel, with wooden cleat, goes on the outside of the front panel).
15	Connect both panels by hammering klimps approximately every two feet along the vertex.
16	Place the lid in position and attach to all side panels and front panel using klimps.

To package the system for transport (continued)

Step	Note
17 Add tip indicators and appropriate labeling	
18 Secure crate to packaging base using band straps	

4 Servicing the System



A Enhancing Measurement Accuracy

- To enhance measurement accuracy [112](#)
- Understanding System Measurement Calibration [114](#)
- Performing a Coaxial System Measurement Calibration [115](#)
- If you encounter a problem [116](#)
- Periodic System Component Calibration [117](#)

Related Topics

- ["Performing the System Functional Verification Test"](#) on page 95
- ["Performing the RF Subsystem Functional Verification Test"](#) on page 125

Use the procedures in this appendix to enhance the accuracy of your measurements.

To enhance measurement accuracy

Follow these instructions to enhance the accuracy of your measurements.

To enhance measurement accuracy

Step	Action	Notes
1 Inspect device connections for foreign materials or connector damage.	<p>a Prior to connecting the DUT, inspect the bias network and semi-rigid RF cable connectors for foreign materials or damage.</p> <p>b Replace any damaged connectors.</p>	<ul style="list-style-type: none"> • Before using connectors for a critical measurement, inspect the connector interfaces with a microscope (~20X). Look for dirt, contaminants, dented or scratched outer conductor mating surfaces, and damaged center conductors.
2 Clean the connectors.	<p>a Remove the systems power cord from the power supply or place the supply breaker in the tripped position.</p> <p>b Move the connectors to a well ventilated area.</p> <p>c Use a swab dipped in clean isopropyl alcohol to cleanse the outer conductor mating surfaces and the ends of the center conductors.</p> <p>d Blow off the remaining alcohol with clean compressed air.</p> <p>e Allow adequate time for the alcohol fumes to disperse before activating the system.</p>	<ul style="list-style-type: none"> • Be careful not to let the alcohol get on the insulator bead, as this may damage the bead. • Be careful not to exert too much force on the center conductors, as they may be damaged. • Compressed air can reduce the temperature of connectors dramatically, and this can have a significant effect upon the performance of calibration and verification components. • If the connector components being cleaned are to be used in a critical measurement application, allow the temperature of these components to stabilize prior to use.
3 Ensure proper system warm-up time.	<p>a Switch on line power to all of the system components.</p> <p>b Allow at least 1 hour warm-up prior to making measurements.</p>	<ul style="list-style-type: none"> • Follow the procedure in "To switch on power to the system" on page 87. • Do not switch off line power to the system unless the system will not be used for an extended period of time.
4 Ensure a proper and constant temperature in the measurement environment.	<p>a Operate the system within an ambient temperature range of 25°C, ±5°C.</p> <p>b After system measurement calibration, hold the ambient temperature of the measurement environment to ±1°C of the ambient temperature at the time of calibration.</p>	<ul style="list-style-type: none"> • Install heating and cooling systems as necessary to maintain proper ambient temperature in the measurement environment.

To enhance measurement accuracy (continued)

Step	Action	Notes
5 Always perform a measurement calibration on the network analyzer prior to making device measurements.	<p>a Prior to making device measurements, complete the steps listed in “Performing a Coaxial System Measurement Calibration” on page 115.</p> <p>b Ensure that the calibration kit elements are seated correctly and firmly in the test set cable connectors.</p>	<ul style="list-style-type: none"> • See “Understanding System Measurement Calibration” on page 114 for more information. • Use the Agilent 85056A 2.4 mm precision calibration kit. • Use the Agilent 85056D 2.4 mm economy calibration kit. • Use the Agilent 85033E 3.5 mm economy calibration kit. • Use the Agilent 85052D 3.5 mm economy calibration kit. • Torque measurement connections using the torque wrench provided in the calibration kit.
6 Calibrate the system components at regular intervals.	<p>a Every 6 to 12 months:</p> <ul style="list-style-type: none"> • Perform the required Agilent E8364B PNA Series vector network analyzer performance verification tests. • Perform the required Agilent 4156C precision semiconductor parameter analyzer performance verification tests. • Perform the required Agilent 4248A precision LCR meter performance verification tests. • Perform the required Agilent E5250A low leakage switch mainframe performance verification tests. 	

Understanding System Measurement Calibration

Measurement accuracy is degraded by the effects of three different types of measurement errors: *systemic*, *drift*, and *random*.

Systemic errors are caused by imperfection in the test equipment and test setup.

Drift errors occur when a test system's performance changes after a calibration has been performed. Drift errors are caused primarily by variations in the ambient temperature of the measurement environment.

Random errors are caused by instrument noise (sampler noise, IF noise floor, etc.), switch repeatability and connector repeatability. These errors vary randomly as a function of time.

You can compensate for systemic and drift errors by performing a system measurement calibration prior to measuring a device. (Performing a measurement calibration has no effect upon random errors.)

To increase the accuracy of your measurements, perform a system measurement calibration before performing device measurements. Repeat the measurement calibration if the ambient temperature of the measurement environment has deviated $\pm 1^{\circ}\text{C}$ since the last measurement calibration.

This procedure performs a modified full 2-port measurement calibration to remove the following errors:

- Directivity
- Source-load match
- Reflection tracking
- Transmission tracking

The isolation calibration (crosstalk correction) has been omitted. Isolation calibration is only required when measuring high-isolation devices such as a switch in the open position or high-dynamic range devices such as filters with a high level of rejection.

Required Tools

- Agilent 85225F performance modeling system
- Agilent 85056A 2.4 mm calibration kit, or
- Agilent 85056D 2.4 mm calibration kit

Performing a Coaxial System Measurement Calibration

Complete the following steps to perform a coaxial system measurement calibration and increase the accuracy of your device measurements. Modify these instructions as necessary to perform an in-fixture or on wafer measurement calibration.

To perform the system measurement calibration

Step	Action	Note
1	Preset the network analyzer.	On the network analyzer, press Preset.
2	Open the Calibration Wizard and choose a guided calibration.	<p>a In the network analyzer's Calibration menu, select Calibration Wizard...</p> <p>b In the Calibration Wizard dialog box, select Use Mechanical Stds... in the Guided Calibrations group box.</p>
3	Choose the DUT connector types.	<p>a In the Guided Calibration: Select DUT Connectors dialog box, select the appropriate DUT connector type for the connections the Port 1 and Port 2 bias networks.</p> <p>b Click Next.</p>
4	Choose the calibration kit.	<p>a In the Guided Calibration: Select Version 2 Cal Kits dialog box, select the appropriate calibration kit (for example 85056D) for the Port 1 and Port 2 bias network.</p> <p>b Click Next.</p>

A Enhancing Measurement Accuracy

To perform the system measurement calibration (continued)

Step	Action	Note
5	<p>Calibrate the network analyzer through the bias networks, cables, and adapters using the standard open, short, load, and through.</p> <p>a Follow the prompts to connect the standard open to the Port 1 bias network RF/DC OUTPUT.</p> <p>b Click Measure.</p> <p>c Follow the prompts to connect the standard short to the Port 1 bias network RF/DC OUTPUT.</p> <p>d Click Measure.</p> <p>e Follow the prompts to connect the standard broadband load to the Port 1 bias network RF/DC OUTPUT.</p> <p>f Click Measure.</p> <p>g Repeat actions <i>a</i> through <i>f</i> for the Port 2 calibration measurements.</p> <p>h Follow the prompts to connect the standard through between the Port 1 and Port 2 bias networks RF/DC OUTPUT. connectors.</p> <p>i Click Measure.</p> <p>j When the measurements are done, in the Standards Measured dialog box, click Next.</p> <p>k In the Guided Calibration Completed dialog box, choose the No, Finish Now radio button and click Finish.</p>	
6	<p>Save the calibration and instrument state data to the <i>C:/Program Files/Agilent/Network Analyzer/Documents</i> folder.</p> <p>a In the File menu, select Save As...</p> <p>b In the Save As dialog box, using the keyboard or by clicking Edit File Name, enter a file name (for instance, <i>MY_CAL.CST</i>), then click OK.</p>	<ul style="list-style-type: none"> This saves the calibration and instrument state data as a file (named for instance, <i>MY_CAL.CST</i>) in the network analyzer's operating system <i>C:/Program Files/Agilent/Network Analyzer/Documents</i> folder.

If you encounter a problem

- ✓ Inspect the connectors on the load, open, short, and through standards and the connectors on the bias networks and the semi-rigid cables.
- ✓ Clean the connectors if necessary. See step 2 in the section titled “[To enhance measurement accuracy](#)” on page 112.
- ✓ If connectors are damaged, replace the standard or cable.
- ✓ Ensure that the standards meet their published specifications.

Periodic System Component Calibration

A complete calibration verifies that the system components meet their individual performance specifications.

The calibration interval depends on the level of system use. Agilent Technologies recommends an initial cycle of 6 to 12 months. Thereafter, adjust the cycle based on the recalibration results.

A complete system calibration consists of the following tests:

- Agilent E8364B PNA Series vector network analyzer performance tests^{*}
- Agilent 4156C precision semiconductor parameter analyzer performance verification[†]
- Agilent E5260A/70B precision parametric measurement solution performance verification
- Agilent 4284A precision LCR meter performance tests
- Agilent 35670A dynamic signal analyzer performance verification
- Agilent E5250A low leakage switch mainframe performance tests

See the individual instrument documentation for instructions on performing the required instrument verification tests.

^{*} Refer to the Agilent E8364B PNA Series vector network analyzer service guide for required performance tests. The service guide (part number E8364-90026) is available at www.agilent.com in PDF format.

[†] Refer to the chapter titled "Performance Verification" in the Agilent 4156C precision semiconductor parameter analyzer service guide, included with the Agilent 4156C documentation.

A Enhancing Measurement Accuracy



B DC Subsystem Functional Verification Test

Understanding the DC Subsystem Functional Verification Test 120

Performing the DC Subsystem Functional Verification Test 121

If you encounter a problem 121

Related Topics

["Performing the System Functional Verification Test" on page 95](#)

["Performing the RF Subsystem Functional Verification Test" on page 125](#)

["Performing the CV Subsystem Functional Verification Test" on page 131](#)

["Performing the 1/f Noise Subsystem Functional Verification Test" on page 135](#)

Use this appendix to perform a DC subsystem functional verification test using the Agilent 4156C precision semiconductor parameter analyzer's front panel interface.

Understanding the DC Subsystem Functional Verification Test

Use this procedure to manually confirm the functionality of the DC subsystem. The procedure provided in [“Performing the DC Subsystem Functional Verification Test”](#) confirms:

For Agilent 4156C subsystems:

- the internal operation of the Agilent 4156C precision semiconductor parameter analyzer

For Agilent E5260A/70B DC subsystems:

- the operation of the Agilent E5260A/70B parametric measurement mainframe
- the operation of the plug-in source monitor units

This procedure runs a self-test initiated from the instrument’s front panel. The test includes a self-calibration routine to improve short-term accuracy.

Required Tools

- Agilent 4156C precision semiconductor parameter analyzer,
- Agilent E5260A/70B parametric measurement mainframe

Performing the DC Subsystem Functional Verification Test

Complete these steps to run the self-test and verify the operation the DC subsystem.

For Agilent 4156C subsystems:

To perform the Agilent 4156C precision semiconductor parameter analyzer self-test

Step	Notes
1	Disconnect all cables from the measurement terminals on the 4156C rear panel.
2	Connect the 4156C to line power.
3	Switch on the instrument line power switch.
4	Wait 1 hour before continuing to step 5 .
5	Press System > [CALIB/DIAG]. <ul style="list-style-type: none"> The analyzer displays the SYSTEM: SELF-CALIBRATION/DIAGNOSTICS screen.
6	Press [DIAG SELFTST ALL]. <ul style="list-style-type: none"> This begins the calibration and self-test process. PASS, FAIL, or DONE appear in the STATUS column. If a failure occurs, an error code is displayed in the ERROR column. See "If you encounter a problem." If no errors occur, DIAG SELF-TEST ALL: PASS appears in the lower left-hand corner of the display.

If you encounter a problem

- ✓ Refer to the Agilent 4156C precision semiconductor parameter analyzer manual titled, "If You Have a Problem" for an explanation of the error codes. See the chapter titled, "If Errors Occur When You Perform Self-Calibration or Diagnostics."
- ✓ Refer to the troubleshooting information in the service manual for the Agilent 4156C precision semiconductor parameter analyzer.

For Agilent E5260A/70B DC subsystems:

To perform the Agilent E5260A/70B precision parametric measurement solution self-test

Step	Notes
1	Disconnect all cables from the measurement terminals on the E5260A/70B front panel.
2	Connect the E5260A/70B to line power.
3	Switch on the instrument line power switch.
4	Wait 1 hour before continuing to step 5 .
5	Press Shift > Menu.
6	Move the cursor to SELFTEST and press Enter. Move the cursor to EXECUTE and press Enter.
7	Use the arrow keys to select ALL and press Enter. At the completion of the test, press Exit three times to exit the setup menu.
8	To display the results, move the cursor to SELFTEST and press Enter. Move the cursor to RESULT and press Enter.
9	Use the arrow keys to select FRAME or Slot n. The test result is displayed for each item.

If you encounter a problem

- ✓ Refer to the Agilent E5260A/70B precision parametric measurement solution user’s guide for an explanation of the error codes. See the section titled “Error Codes” in the chapter titled, “If You Have a Problem.”
- ✓ Refer to the troubleshooting information in the Agilent E5260A/70B precision parametric measurement solution service manual.

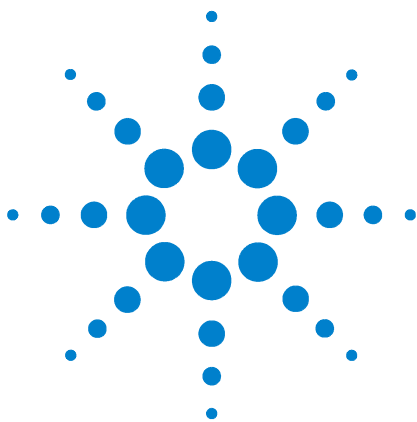

C RF Subsystem Functional Verification Test

Understanding the RF Subsystem Functional Verification Test [124](#)

Performing the RF Subsystem Functional Verification Test [125](#)

If you encounter a problem [127](#)

Related Topics

["Performing the System Functional Verification Test"](#) on page 95

["Performing the DC Subsystem Functional Verification Test"](#) on page 121

["Performing the CV Subsystem Functional Verification Test"](#) on page 131

["Performing the 1/f Noise Subsystem Functional Verification Test"](#) on page 135

Use the instructions in this appendix to perform a manual RF subsystem functional verification test.

Understanding the RF Subsystem Functional Verification Test

Use the procedure provided in “[Performing the RF Subsystem Functional Verification Test](#)” to manually confirm the functionality of the Agilent E8364B PNA Series vector network analyzer system. This procedure does not verify performance to specification. This procedure confirms that the network analyzer is ready for performance verification and/or operation by confirming the following hardware functionality:

- the repeatability of the RF switch in the test set
- the attenuation range of the test port attenuators

Required Tools

- Agilent E8364B PNA Series vector network analyzer
- Test port cable
- a standard short from the network analyzer calibration kit

Performing the RF Subsystem Functional Verification Test

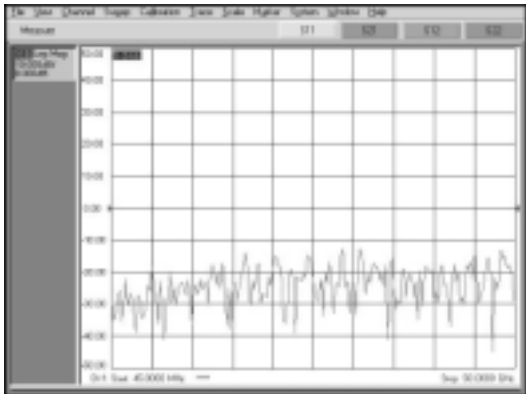

If the performance of the Agilent E8364B PNA Series vector network analyzer is in question, complete the following steps to verify operation.

To perform the RF subsystem functional verification test

Step	Action	Notes
1	<p>Activate the network analyzer.</p> <p>a Connect the network analyzer to line power.</p> <p>b Switch on the line power.</p>	
2	<p>Warm-up the network analyzer for 1 hour.</p> <p>a Wait 1 hour before continuing to step 3.</p>	
3	<p>Run the Operator's Check.</p> <p>a In the network analyzer System menu, point to Service and click Operator's Check.</p> <p>b Click Configure.</p> <p>c On the pull down menu, select Automatic.</p> <p>d Click Start-Port 1.</p> <p>e Follow the program prompts.</p> <p>f When prompted, place a short on Port 1 and click OK.</p> <p>g Check PASS/FAIL status.</p> <p>h Continue to follow the prompts for the Attenuator Range tests.</p> <p>i Check PASS/FAIL status for each attenuator range.</p> <p>j Click Start-Port 2.</p> <p>k Repeat actions e through i for Port 2.</p> <p>l Click Exit to end the Operator's Check.</p>	<ul style="list-style-type: none"> • This opens the Operator's Check window. • This selects automatic program execution. To enable a prompted test sequence, choose Prompted to place a prompt before the execution of each range test for each attenuator. • When the Port 1 test is complete, the Operator's Check window reappears showing the test results for Port 1. • When the Port 2 test is complete, the Operator's Check window reappears showing the test results for Port 2.
4	<p>Test the forward reflection mode for channel 1.</p> <p>a Connect the test port cable between the PORT 1 and PORT 2 connectors.</p> <p>b Press Preset. (By default, the instrument measures channel 1 forward reflection after instrument preset.</p> <p>c Inspect the trace shown on the display. It should be similar to the trace shown to the right.</p>	

C RF Subsystem Functional Verification Test

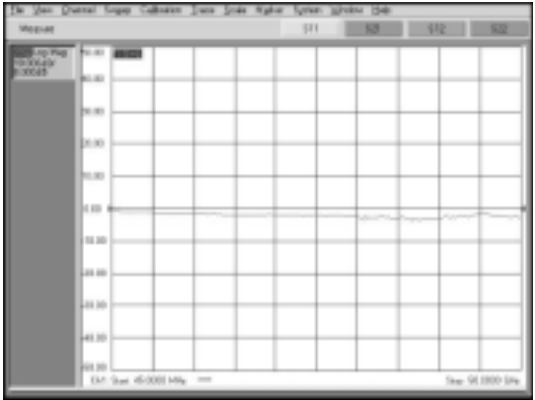
To perform the RF subsystem functional verification test (continued)

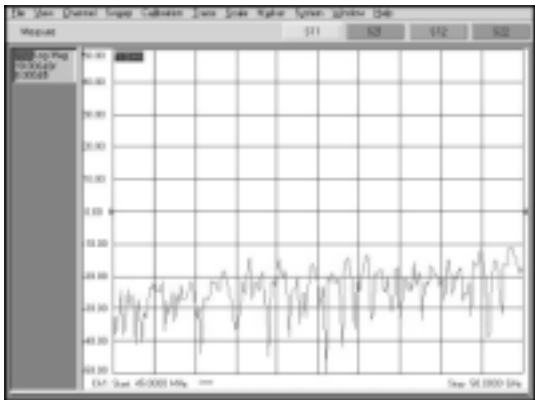
Step	Action	Notes
5 Test the forward transmission mode for channel 1.	<ul style="list-style-type: none"> a From the Trace drop down menu, point to Measure and click S21. b Inspect the trace shown on the display. It should be similar to the trace shown to the right. 	
6 Test the reverse transmission mode for channel 1.	<ul style="list-style-type: none"> a From the Trace drop down menu, point to Measure and click S12. b Inspect the trace shown on the display. It should be similar to the trace shown to the right. 	
7 Test the reverse reflection mode for channel 1.	<ul style="list-style-type: none"> a From the Trace drop down menu, point to Measure and click S22. b Inspect the trace shown on the display. It should be similar to the trace shown to the right. 	

If you encounter a problem

- ✓ Check the GPIB cable and connection.
- ✓ Check the GPIB address.
- ✓ Consult the “Troubleshooting” chapter of the Agilent E8364B PNA Series vector network analyzer service guide for troubleshooting information.

C RF Subsystem Functional Verification Test

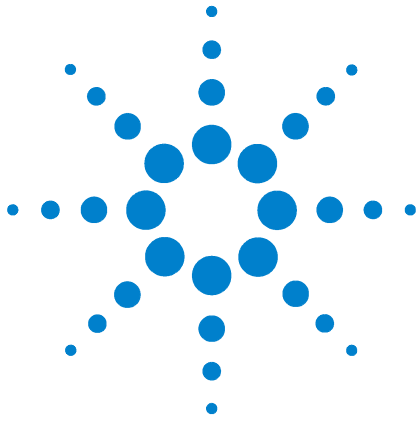

D CV Subsystem Functional Verification Test

Understanding the CV Subsystem Functional Verification Test [130](#)

Performing the CV Subsystem Functional Verification Test [131](#)

If you encounter a problem [132](#)

Related Topics

["Performing the System Functional Verification Test"](#) on page 95

["Performing the RF Subsystem Functional Verification Test"](#) on page 125

["Performing the DC Subsystem Functional Verification Test"](#) on page 121

Use the instructions in this appendix to perform a manual CV subsystem functional verification test.

Understanding the CV Subsystem Functional Verification Test

Use the procedure provided in “[Performing the CV Subsystem Functional Verification Test](#)” to manually confirm the functionality of the Agilent 4284A precision LCR meter. This procedure does not verify performance to specification. This procedure confirms that the precision LCR meter is ready for performance verification and/or operation by confirming the following hardware functionality:

- memory card read/write test
- LED display test
- LCD display test
- handler I/F test
- scanner I/F EEPROM read/write test
- scanner I/F I/O test
- bias current I/F I/O test

Required Tools

See Chapter 10 of the Agilent 4284A precision LCR meter operation manual.

Performing the CV Subsystem Functional Verification Test

If the performance of the Agilent 4284A precision LCR meter is in question, complete the following steps to verify operation.

To perform the RF subsystem functional verification test

Step	Action	Notes
1	Activate the precision LCR meter. <ol style="list-style-type: none"> a Connect the precision LCR meter to line power. b Switch on the line power. 	
2	Warm-up the network analyzer for 1 hour. <ol style="list-style-type: none"> a Wait 1 hour before continuing to step 3. 	
3	Run the required self tests. <ol style="list-style-type: none"> a On the precision LCR meter front panel, press CATALOG/SYSTEM > SELF TEST. b Enter the number corresponding to the required self test and press SELF TEST. 	<ul style="list-style-type: none"> • This opens the SELF TEST page. • For more information, see chapter 5 “Catalog/System Configuration” in the Agilent 4284A precision LCR meter operation manual.

If you encounter a problem

- ✓ Check the GPIB cable and connection.
- ✓ Check the GPIB address.
- ✓ Consult the Agilent 4284A precision LCR meter service guide for troubleshooting information.

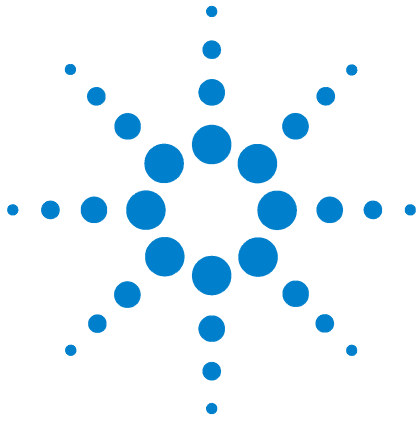

E 1/f Noise Subsystem Functional Verification Test

Understanding the 1/f Noise Subsystem Functional Verification Test [134](#)

Performing the 1/f Noise Subsystem Functional Verification Test [135](#)

If you encounter a problem [136](#)

Related Topics

["Performing the System Functional Verification Test"](#) on page 95

["Performing the DC Subsystem Functional Verification Test"](#) on page 121

["Performing the RF Subsystem Functional Verification Test"](#) on page 125

["Performing the CV Subsystem Functional Verification Test"](#) on page 131

Use the instructions in this appendix to perform a manual 1/f noise subsystem functional verification test.

Understanding the 1/f Noise Subsystem Functional Verification Test

Use the procedure provided in [“Performing the 1/f Noise Subsystem Functional Verification Test”](#) to manually confirm the functionality of the Agilent system. This procedure does not verify performance to specification. This procedure confirms that the network analyzer is ready for performance verification and/or operation.

Required Tools

- Agilent 35670A dynamic signal analyzer

Performing the 1/f Noise Subsystem Functional Verification Test

If the performance of the Agilent 35670A dynamic signal analyzer is in question, complete the following steps to verify operation.

To perform the RF subsystem functional verification test

Step	Action	Notes
1 Activate the dynamic signal analyzer.	<ul style="list-style-type: none"> a Connect the dynamic signal analyzer to line power. b Switch on the line power. 	The instrument performs the self test during power-up.
2 View the results.	<ul style="list-style-type: none"> a Observe the results on the analyzer display. 	If the instrument self test fails, consult "Chapter 4. Troubleshooting the Analyzer," in the Agilent 35670A dynamic signal analyzer service guide.

If you encounter a problem

- ✓ Check the GPIB cable and connection.
- ✓ Check the GPIB address.
- ✓ Consult the “Chapter 4. Troubleshooting the Analyzer” in the Agilent 35670A dynamic signal analyzer service guide for troubleshooting information.

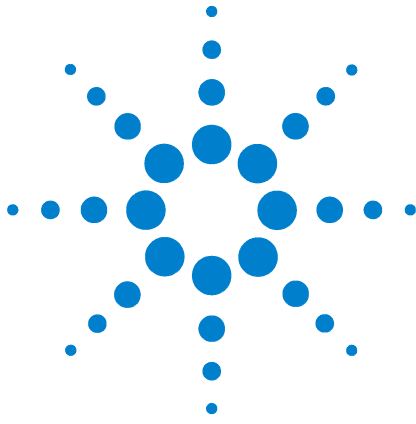

F Understanding the Bias Networks

Features	138
Characteristics	139
Operation	140
Bias Network Schematic	140

Related Topics

["To connect the bias networks"](#) on page 80

["Performing a Coaxial System Measurement Calibration"](#) on page 115

Use this appendix to learn more about the bias networks. This appendix includes a list of features, connections, a table of device characteristics, information on internal operation, and a schematic diagram of the bias networks.

Features

Using the Agilent 11612V K11 and K21 bias networks, you can simultaneously supply DC bias and RF energy to the device under test (without the need to use patch cables or adapters) to make convenient and accurate DC and S-parameter measurements.

Each bias network provides:

- floating triaxial FORCE connection to *input* current or voltage
- floating triaxial SENSE connection to *monitor* voltage or current
- floating triaxial GNDU connection to implement an active ground
- 2.4 mm coaxial RF input
- 2.4 mm coaxial combined RF/DC output
- device bias oscillation suppression

Characteristics

Table 20 11612V Option K11/K21 Bias Network Characteristics

Parameter	11612V Option K11	11612V Option K21
Test port	Port 1	Port 2
Frequency range	45 MHz to 50 GHz	45 MHz to 50 GHz
Test port connector	2.4 mm	2.4 mm
Maximum current	0.5 amps	0.5 amps
Maximum voltage	40 volts	40 volts
Maximum RF power	2 watts (+33 dBm)	2 watts (+33 dBm)
Height	50 mm (2 inches)	50 mm (2 inches)
Width	105 mm (3.5 inches)	105 mm (3.5 inches)
Depth	70 mm (2.75 inches)	70 mm (2.75 inches)
Net weight	370 grams (0.8 pounds)	370 grams (0.8 pounds)

CAUTION

Do not exceed the maximum ratings of the bias networks. Failure to comply can result in severe damage.

Operation

Each bias network includes two bias tees, one for force and one for sense. The force bias tee includes a capacitor in the RF signal path that functions as a high-pass filter and DC block. The sense bias tee provides a through path for DC. Both force and sense tees include resistive-capacitive oscillation suppression circuitry to help prevent low frequency bias oscillation of the device under test. Refer to [Figure 24](#).

Figure 24 Bias Network Schematic

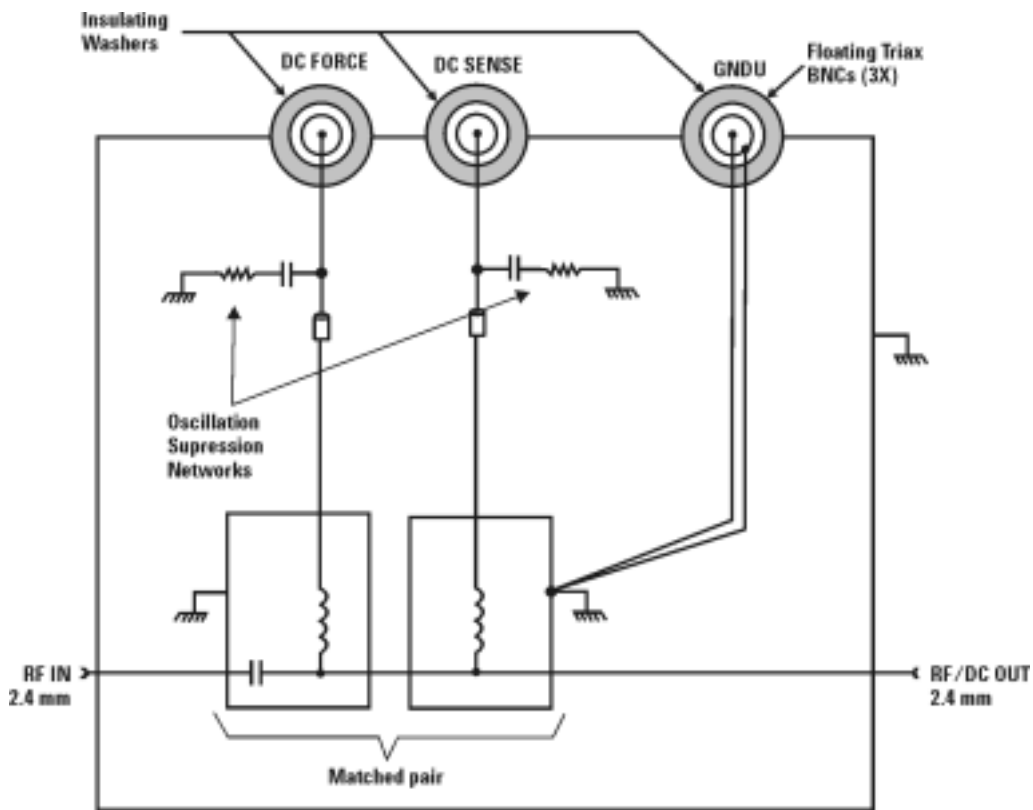



G Network Analyzer Performance Specification Summary

Network Analyzer System Performance 142

Dynamic Range 142

Measurement Uncertainty 143

Related Topics

["RF and DC Measurement System Configuration"](#) on page 19

["Performance Characteristics and Specifications"](#) on page 61

Use this appendix to reference a summary of the network analyzer performance specifications.

Network Analyzer System Performance

The following specifications describe the system performance of the Agilent E8364B PNA Series vector network analyzer Option 014 and UNL configuration for measurements between 45 MHz and 50 GHz.

Calibration Kit	Agilent 85056A, 2.4 mm precision, with sliding loads
Cables	Agilent 85133F, 2.4 mm flexible test port cable set
Calibration Type	Full 2-port with sliding loads
Temperature Range	25°C ±5°C
Warm-up Time	≥ 0.5 hour

Maximum Output Power

	Frequency Range (GHz)					
	0.045 to 10.0	10.0 to 20.0	20.0 to 30.0	30.0 to 40.0	40.0 to 45.0	45.0 to 50.0
Maximum output power	+3 dBm	0 dBm	-4 dBm	-8 dBm	-11 dBm	-17 dBm

Dynamic Range

System dynamic range is calculated as the difference between the noise floor and the source maximum output power. Reflection measurements are limited by directivity. Therefore, system dynamic range only applies to transmission measurements.

	Frequency Range (GHz)							
	0.045 to 0.5	0.5 to 2.0	2.0 to 10.0	10.0 to 20.0	20.0 to 30.0	30.0 to 40.0	40.0 to 45.0	45.0 to 50.0
System dynamic range	92 dB	117 dB	120 dB	119 dB	109 dB	105 dB	102 dB	95 dB

Measurement Port Characteristics

Residual	Frequency Range (GHz)			
	0.045 to 2.0	2.0 to 20.0	20.0 to 40.0	40.0 to 50.0
Directivity	42 dB	42 dB	38 dB	36 dB
Source match	41 dB	38 dB	33 dB	31 dB
Load match	42 dB	42 dB	37 dB	35 dB
Reflection tracking	$\pm(0.001 + 0.2 \text{ dB}/^\circ\text{C})$	$\pm(0.008 + 0.2 \text{ dB}/^\circ\text{C})$	$\pm(0.020 + 0.3 \text{ dB}/^\circ\text{C})$	$\pm(0.027 + 0.4 \text{ dB}/^\circ\text{C})$
Transmission tracking	$\pm(0.019 + 0.2 \text{ dB}/^\circ\text{C})$	$\pm(0.053 + 0.2 \text{ dB}/^\circ\text{C})$	$\pm(0.114 + 0.3 \text{ dB}/^\circ\text{C})$	$\pm(0.215 + 0.4 \text{ dB}/^\circ\text{C})$

Measurement Uncertainty

Measurement uncertainty curves utilize an RSS (Root Sum Square) model for the contribution of random errors such as noise and typical connector and test set switch repeatabilities. These are combined with a worst-case model for the contributions of dynamic accuracy and residual systemic errors.

Curves show the worst-case magnitude and phase uncertainty for reflection and transmission measurements, using the specified cal kit, with 10 Hz IF bandwidth, and no averaging during the measurement.

Reflection Measurements

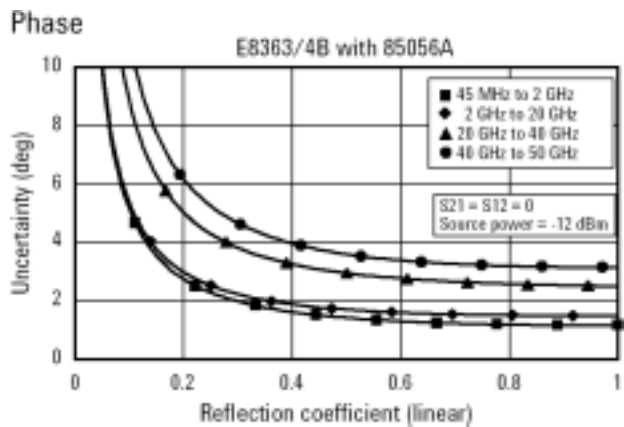
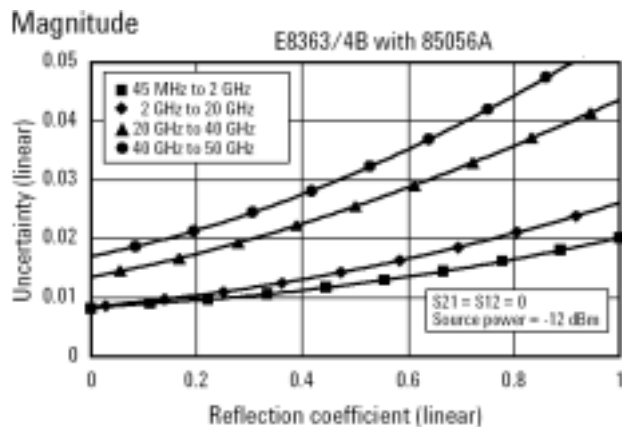

Transmission Measurements

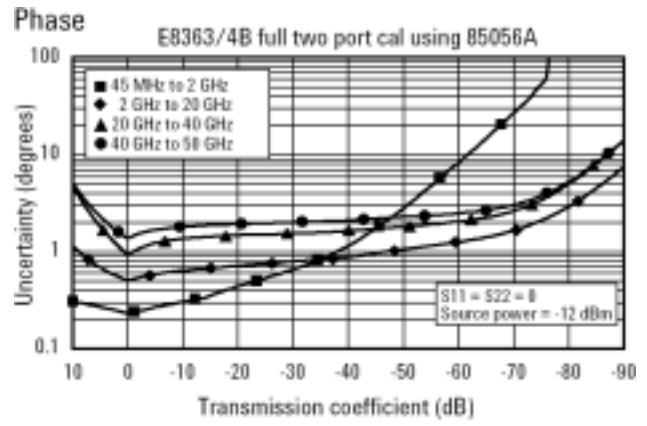
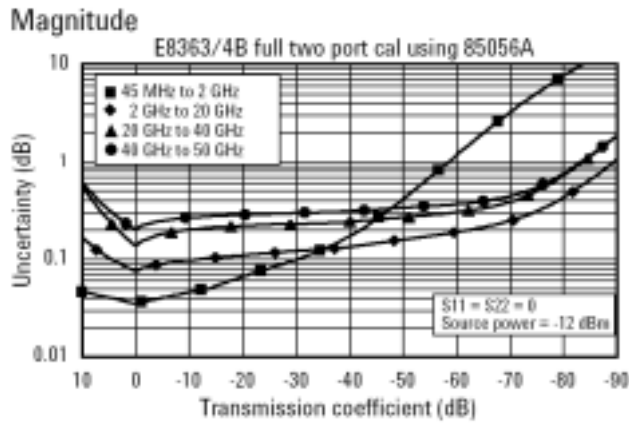

Index

Numerics

11612V. *See* bias networks
2.4 mm (f-to-f) adapter, [69, 94](#)
2.4 mm (f-to-m) adapter, [69, 81, 83, 85, 94](#)
2.4 mm (m-to-f) adapter, [69](#)
2.4 mm (m-to-m) adapter, [69, 81, 83, 85, 94](#)
35670A. *See* dynamic signal analyzer
41501B. *See* expander, SMU PGU
4156C. *See* parameter analyzer
4284A. *See* LCR meter

A

accuracy, enhancing measurement, [112](#)
activation procedure, system, [87](#)
adapter, 2.4 mm (f-to-f), [69, 94](#)
adapter, 2.4 mm (f-to-m), [69, 81, 83, 85, 94](#)
adapter, 2.4 mm (m-to-f), [69](#)
adapter, 2.4 mm (m-to-m), [69, 81, 83, 85, 94](#)
altitude requirements, [64](#)
assistance, to receive additional, [107](#)
attenuator
 fixed, 10 dB, [71](#)
 test model, IC-CAP, [97](#)

B

ballast, [71](#)
bias networks
 characteristics, [139](#)
 connection procedure, [80](#)
 connections, system, [80](#)
 features, [138](#)
 operational theory, [140](#)
 overview, [21](#)
block diagram, 1/f noise measurement, [47](#)
block diagram, CV system, [33](#)
block diagram, system, [19](#)

C

cable set, test port, [71](#)
cable(s)
 GPIB, [69](#)
 line power, [71](#)
 semi-rigid, [71](#)
 SMU triaxial, [69, 70](#)
 test set, [71](#)
cabling diagram, DC/RF, [32, 40, 41, 54, 55](#)
calibration
 component, [113, 117](#)

isolation, [114](#)
 kit, [71](#)
 measurement, [113, 115](#)
cautions
 bending packing clamps, [66](#)
 bias network voltage/current rating, [21, 139](#)
 circuit breaker protection, [7](#)
 definition of caution label, [3](#)
 electrostatic discharge, [79](#)
 front panel line switch, [8](#)
 line power disconnection, [7](#)
 line power settings, [7](#)
 mains cable connection, [7](#)
 overcurrent protection, [8](#)
characteristics
 bias networks, [139](#)
 measurement port, [143](#)
 supplemental system, [61](#)
checklist, receiving, [69](#)
cleaning, connector, [112](#)
clearance requirements, rack, [64](#)
compliance with
 electrostatic discharge immunity test, [9](#)
 EMC requirements, [9](#)
 noise requirements, [9](#)
 surge immunity test, [9](#)
compliance, CSA 1010, [8](#)
compliance, statement of, [8](#)
conformity, declaration of, [8](#)
connections, system, [28, 36, 50, 52](#)
controller, system
 overview, [59](#)
CPU requirements, controller, [59](#)
crate, shipment
 packing procedure, [108](#)
 unpacking procedure, [66](#)
CSA 1010 compliance, [8](#)
customer support, Agilent Technologies, [107](#)

D

DC subsystem. *See* parameter analyzer or parametric measurement solution
declaration of conformity, [8](#)
diagrams
 block, 1/f noise measurement, [47](#)
 block, CV system, [33](#)
 block, system, [19](#)
 cabling, DC/RF, [32, 40, 41, 54, 55](#)
 integration, system component, [35, 49](#)
 reflection uncertainty, network analyzer, [143](#)
 test setup, verification, [95](#)

transmission uncertainty, network analyzer, [144](#)
 wiring, system, [27, 29, 37, 39, 51, 53](#)
digital multimeter, GPIB address, [56](#)
display requirements, controller, [59](#)
drift measurement errors, [114](#)
dynamic range, [114, 142](#)
dynamic signal analyzer
 calibration cycle, [117](#)
 functional verification procedure, manual, [134](#)
 GPIB address, [56](#)
 overview, [46](#)

E

E5250A. *See* switch mainframe
E5260A/70B. *See* parametric measurement solution
E5810A. *See* LAN/GPIB gateway
E8364B. *See* network analyzer
electrical requirements, [64](#)
electrostatic discharge
 immunity test, compliance with, [9](#)
 precautions against, [79](#)
EMC requirements, compliance with, [9](#)
environmental requirements, [64](#)
errors, measurement, correcting, [114](#)
expander, SMU PGU
 overview, [20](#)
extractor fan, [71](#)

F

fan, extractor, [71](#)
feedthrough panels, [71](#)
floating-ground measurements
 procedure, [78](#)
 safety precautions, [78](#)
functional verification procedure
 dynamic signal analyzer, manual, [135](#)
 LCR meter, manual, [131](#)
 network analyzer, manual, [125](#)
 system, remote, [95](#)

G

GPIB
 addresses, [56](#)
 cables, [69](#)
 connections, [29, 39, 53](#)

H

handle kit, rack mount and, 70, 71, 105
 hard disk requirements, controller, 59
 hardware setup, IC-CAP, 89, 96

I

IC-CAP software
 adding components, 89, 96
 adding interface, 96
 changing SMU names, 96
 configuring the interface, 89
 DC characterization, 99
 opening attenuator test model, 97
 saving the hardware configuration, 100
 setting network analyzer options, 97
 starting the program, 89, 96
 user's guide, 89, 100
 inspection
 connector surfaces, 112
 incoming shipment, 65, 68
 installation procedure, 64
 instrument markings, 5
 integration
 description, 22, 34, 48
 diagram, system, 35, 49
 interface setup, IC-CAP, 89
 interference standards, 61
 isolation calibration, 114

L

LAN/GPIB gateway
 configuration procedure, 89
 default server address, 89
 GPIB address, 56
 overview, 57
 LCR meter
 functional verification, 100
 functional verification procedure,
 manual, 130
 GPIB address, 56
 options, setting in IC-CAP, 100
 overview, 34
 troubleshooting, 104
 line power
 activating system, 87
 cables, 71
 requirements
 circuit sharing, 64
 supply capability, 64

M

maintenance, connector, 112
 manual part number, 71
 markings, instrument, 5
 measurement
 accuracy, enhancing, 112
 calibration, 115

description, 114
 procedure, 115
 DC characterization, using IC-CAP, 99
 errors, correcting, 114
 uncertainties
 correcting, 115
 reflection, 143
 transmission, 144
 model/part numbers, 69
 mounting plates, probe station, 69

N

network analyzer
 calibration
 cycle, 117
 procedure, 98, 116
 connections, system, 28, 36, 50, 52
 functional verification procedure,
 manual, 124
 GPIB address, 56
 options, setting IC-CAP, 97
 overview, 20
 specification summary, performance, 142
 noise requirements, compliance with, 9

O

operating system requirements, controller, 59
 output power, maximum, 142

P

panels
 feedthrough, 71
 filler, 72
 parameter analyzer
 calibration cycle, 117
 functional verification procedure,
 manual, 121
 GPIB address, 56
 parametric measurement solution
 calibration cycle, 117
 connections, system, 28, 36, 50, 52
 GPIB address, 56
 specifications, 62
 parts, replaceable
 list of, 69
 ordering, 106
 power, maximum output, 142
 precision parametric measurement solution
 GPIB address, 56
 procedures
 activating system line power, 87
 bias network connection, 80
 calibration, measurement, 115
 floating ground measurement, 78
 functional verification
 dynamic signal analyzer, 134

full system, 95
 LCR meter, 130
 network analyzer, 124
 parameter analyzer, 121
 installation, 64
 LAN/GPIB interface configuration in
 IC-CAP, 89
 removal and replacement, component, 105
 safety precautions, 76
 shipment reception, 65
 site preparation, 64
 troubleshooting, system, 104
 unpacking shipment crate, 66
 work surface installation, 74

R

rack
 cabinet, 60, 71
 mount kit, 70, 71, 105
 rail kits, 71
 RAM requirements, controller, 59
 random measurement errors, 114
 receiving checklist, 69
 reflection uncertainty, network analyzer, 143
 relative humidity requirements, 64
 removal and replacement, component, 105
 replaceable parts
 list of, 69
 ordering, 106
 required tools
 crate, unpacking shipment, 66
 DC source/monitor functional
 verification, 120
 measurement calibration, 114
 modeling system functional verification, 94
 network analyzer functional verification, 124,
 130, 134
 work surface installation, 74
 requirements
 controller
 pc, 59
 UNIX, 59
 system
 electrical, 64
 environmental, 64
 requirements, safety, 5
 results, interpreting, 99
 RF subsystem. *See* network analyzer

S

safety
 precautions
 floating-ground measurements, 78
 general, 76
 procedure, 76
 requirements, 5
 symbols, descriptions, 4

- schematic diagrams
 - DC/RF signal flow, [32, 40, 41, 54, 55](#)
- semi-rigid cables, [71](#)
- shipment reception procedure, [65](#)
- site preparation procedure, [64](#)
- SMU names, IC-CAP, [96](#)
- SMU triaxial cables, [69, 70](#)
- specifications, performance
 - E8364B network analyzer, [142](#)
 - parametric measurement solution, [62](#)
- standards, interference, [61](#)
- statement of compliance, [8](#)
- support, customer, [107](#)
- surge immunity test, compliance with, [9](#)
- swap space requirements, controller, [59](#)
- switch mainframe
 - GPIO address, [56](#)
 - overview, [42](#)
 - troubleshooting, [104](#)
- symbols, safety, [4](#)
- systemic measurement errors, [114](#)

T

- temperature requirements, [64](#)
- test setup diagram, verification, [95](#)
- tools, required. *See* required tools
- transmission uncertainty, network analyzer, [144](#)
- troubleshooting
 - calibration, measurement, [116](#)
 - LAN/GPIB gateway, [104](#)
 - modeling system, [104](#)
 - network analyzer manual verification, [127, 132, 136](#)
 - parameter analyzer manual verification, [121](#)

U

- uncertainties, measurement
 - correcting, [115](#)
 - reflection, [143](#)
 - transmission, [144](#)

V

- verification, functional
 - description of choices, [92](#)
 - dynamic signal analyzer
 - procedure, manual, [135](#)
 - LCR meter, [100](#)
 - procedure, manual, [131](#)
 - modeling system
 - description, [94](#)
 - procedure, remote, [95](#)
 - network analyzer
 - description, [124, 130, 134](#)
 - procedure, manual, [125](#)
 - parameter analyzer
 - description, [120](#)
 - procedure, manual, [121](#)

- parametric measurement solution
 - description, [120](#)
- virtual memory requirements, controller, [59](#)

W

- warnings
 - cover removal, [105](#)
 - dangerous voltages present, [76, 78](#)
 - definition of warning label, [3](#)
 - eye protection during unpacking, [66](#)
 - moving the rack cabinet, [67](#)
 - precautions for cleaning, [8](#)
 - protective earth contact interruption, [6](#)
 - protective earth ground connection, [8](#)
 - Safety Class 1 product, [6](#)
 - service with qualified personnel only, [6](#)
 - servicing by qualified personnel only, [105](#)
 - unspecified use, [6](#)
 - use in explosive atmosphere, [6](#)
- window manager requirements, controller, [59](#)
- wiring diagram, system, [27, 29, 37, 39, 51, 53](#)
- work surface
 - installation procedure, [74](#)
 - part number, [71](#)

