



opus

USER MANUAL

Opus 1

Opus 2

Opus 3

Tri-centre

Tri-surround

Wharfedale

CONTENTS

- User Warnings
- Quick Start Guide
- About Your Loudspeaker
- Specifications
- Quality Assurance

WITHIN THIS PACK

- Certificate of Quality Assurance
- Systems and Driver Unit Test Reports
- 4 x White Cotton Gloves
- Accessories

USER WARNINGS

Please read the following notes carefully. They will help you to install your loudspeakers correctly and safely.

- Switch off the amplifier and all sources before making connections to your sound system. When you switch on the system or change sources, set the volume control to minimum and turn up the level gradually.
- The position of your Volume Control is NOT a reliable guide as to the maximum capabilities of your system. Playing the system with extreme settings of volume and tone controls may damage the amplifier and loudspeakers.
- Do not connect loudspeaker terminals to the mains supply.
- Ensure that your loudspeakers are correctly wired and are in phase.
- Do not subject your loudspeakers to excessive cold, heat or sunlight.
- **WARNING:** To reduce the risk of fire or electrical shock do not expose this product to rain or moisture. The product must not be exposed to dripping and splashing and no object filled with liquids – such as a vase of flowers – should be placed on the product.
- No naked flame sources – such as candles – must be placed on the product.
- Do not place heavy objects on top of loudspeaker cabinets. If you play them with the grilles removed be careful to protect the drive units from children and pets.
- Do not use makeshift stands. Always fit a manufacturer' approved stand using the instructions and the fixings provided. Your dealer will advise you.
- Do not attempt to dismantle the loudspeaker. There are no user serviceable parts inside and you will invalidate the warranty.
- Site your loudspeaker at least 0.5m away from TV sets and magnetic storage media.

QUICK SETUP GUIDE
(Opus Series)

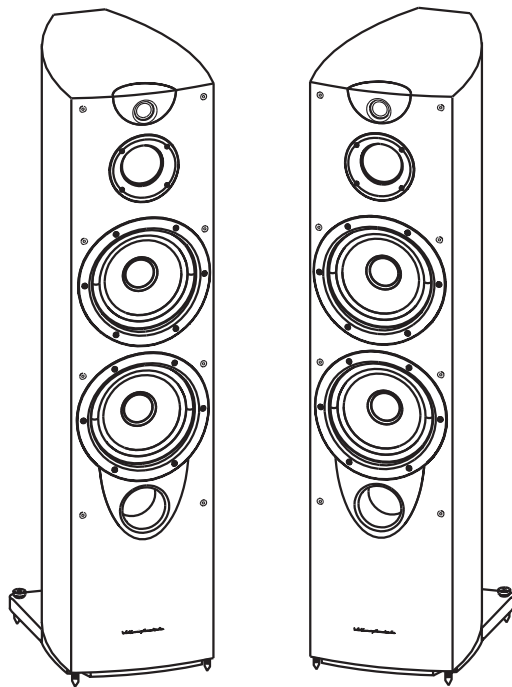

Wharfedale

Wharfedale

Setting Up the Opus Series

- Safely unpacking
- Check you have
- Loudspeaker preparation
- Positioning stereo Hi-fi speakers
- Connecting stereo Hi-fi speakers
- Positioning AV speakers
- Connecting AV speakers
- Setting up AV systems
- Looking after your loudspeakers

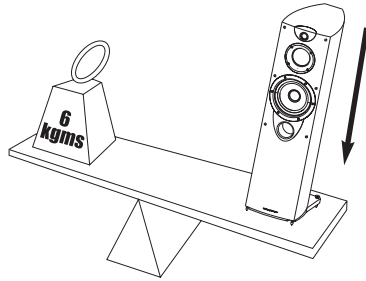

Your Opus speakers are heavy. Take care when removing them from their packaging.

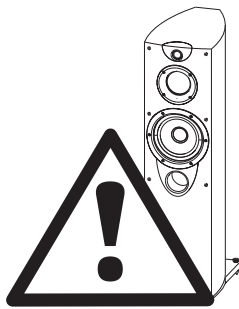

Always take care when lifting heavy objects.
Lift the speakers out by their sides.

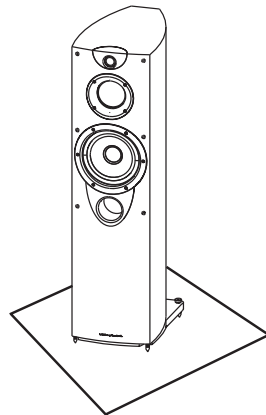

Carefully remove each loudspeaker from its packing carton. Be especially careful when removing the polythene bag. The speakers come with the plinth complete and already fitted. The carton top says, "Open other end". So you,

- Open the bottom
- Remove polystyrene
- Open bag containing speaker
- Tape the carton flaps back
- Turn over carton with loudspeaker still inside
- Lift carton off, leaving loudspeaker standing on the floor
- Be careful not to damage soft floor surfaces with spikes

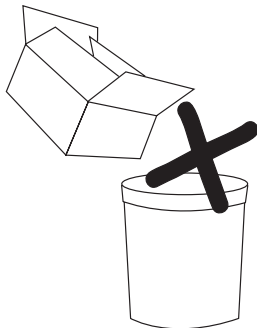

If possible, keep the packaging in case you need to move or return your speakers.

CHECK YOU HAVE

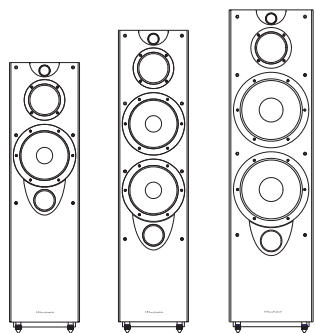

Opus 1, 2, 3

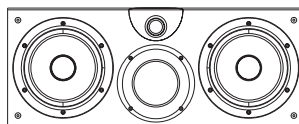

Opus Tri-Centre

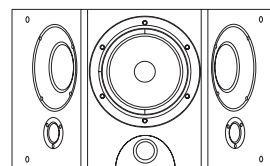

Opus Tri-Surround

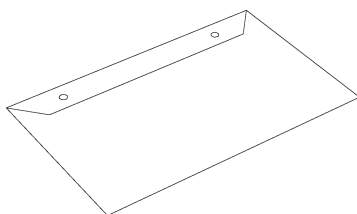

User Pack

Accessories:

- 4 Gloves
- Long spike set (4)
- Soft floor spike seats
- Foam pad (4)
- Bi-wire Links (4)

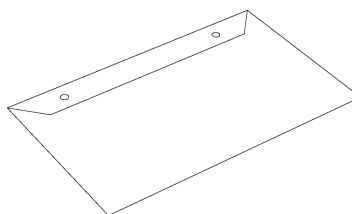

User Pack

Accessories:

- 2 Gloves
- Rubber Feet
- Bi-wire Links

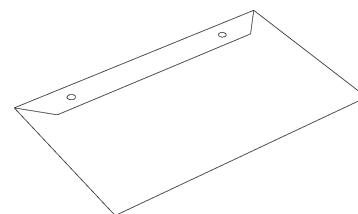

User Pack

Accessories:

- 2 Gloves
- Rubber Feet

OPUS 1, 2 & 3 SPIKES

Your floor standing Opus speakers are delivered with the plinth and spikes already fitted. Levelling/seating the speaker is best achieved by adjusting either of the rear spikes until the speaker is stable without rocking. Release the top knob, on the underside. Turn spike out and down to level. Re-lock top knob. For wood or soft floors 8 metal spike seats and self-adhesive pads are provided for use as required. A set of extra long spikes for deep carpets are provided and may be used as required.

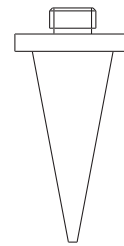

WARNING: Opus speakers are heavy and the spikes can penetrate softer floors materials over extended periods.

CONNECTIONS AND TERMINALS

Choosing and Preparing Cables

Specialist audio cable usually offers better performance than general purpose 'bell' or 'zip' wire.

Choose a cable of suitable diameter – cable that is too thin will limit the dynamics of the sound and may impair the bass response. Audio cable is polarised, with two cores of different colours, or often a raised rib of coloured tracer in the case of twin cable.

Split the twin cores to a depth of about 40mm. Carefully strip the insulation from each end, leaving about 10mm of bare wire. If the cable is stranded, lightly twist to gather any loose strands.

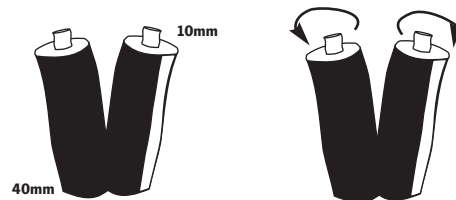

Crossover Networks

OPUS front and centre loudspeakers use a specially designed bi-wireable crossover panel with six terminal binding posts. Please follow the drawing carefully to see the correct orientation of the loudspeaker terminals. The upper terminals connect to the treble unit, the middle pair to the mid-range and the lower pair to the bass units. As supplied, the treble terminal pair is connected to the mid-range pair and bass terminal pair via removable metal straps. These should be left in place for standard single cable installations. The OPUS surround uses a conventional twin terminal crossover panel.

Connecting Loudspeaker Terminals

Unscrew the terminal. Thread the bored end of each cable through the hole in the bottom of the terminal post. Ensure that there are no loose strands which may touch adjacent terminals. Retighten the terminal securely.

NOTE: When connecting loudspeakers, the cables to left and right channels should be of equal length, regardless of the distance of the speakers from the amplifier. This applies to front and rear channels.

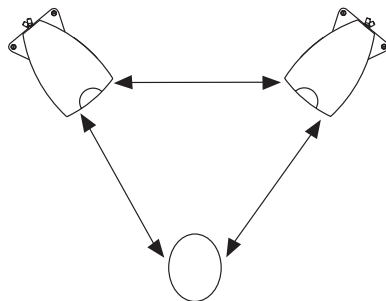

Positioning the speakers. Place the speakers so that you are the same distance from each. The distance between the speakers should be the same as between you and the speakers.

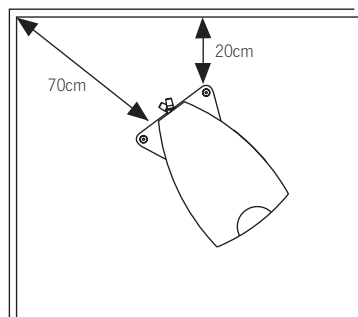

For best results the speakers should be at best 10 inches (20cm) in front of a wall and at least 30 inches (70cm) from any corner.

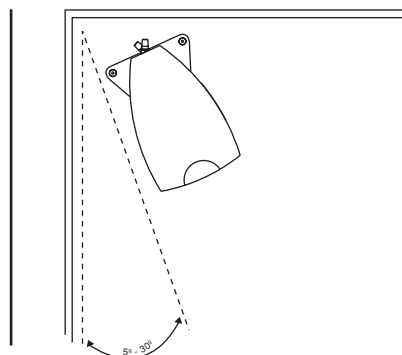

Angle speakers inward by 5° to 30° for a clearer, more tuneful mid range.

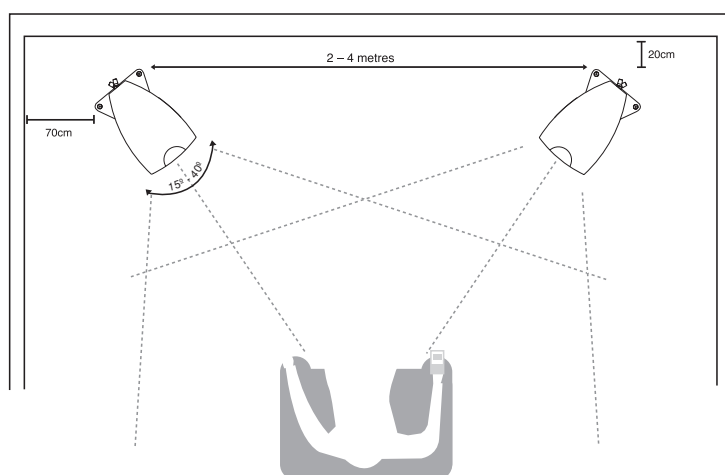

If the loudspeakers are placed too close to the walls the bass will increase but may be boomy and indistinct. If the loudspeakers are placed further away from the walls, the inward angle may be increased by upto 40%, although this may restrict the width of the optimum listening position. As personal taste plays a large role, experiment with different configurations and play a wide range of programme before finalising the position of your speakers.

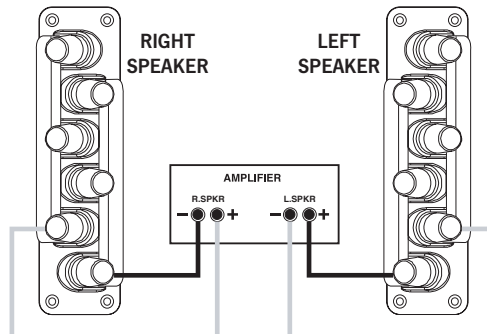

Single wired a single amplifier, tri-link bar is fitted

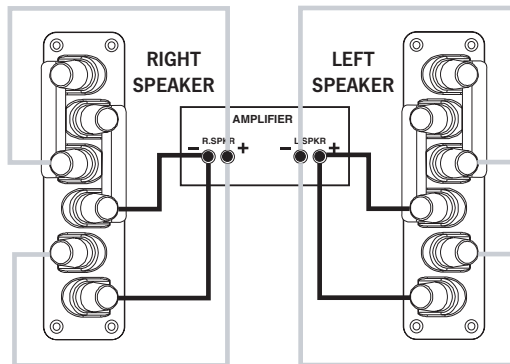

Tri or Bi-wired - a single amplifier, with separate wires to drive the bass/mid unit and the treble unit. Additional links are supplied to allow Bi-wiring.

Using separate cables for treble, mid and bass units in Tri or Bi-wiring configuration reduces intermodulation effects and improves headroom and clarity. To Bi-wire, you will need to install two lengths of twin core cable between the amplifier and each loudspeaker. Unscrew each terminal a few turns and remove the metal tri-link straps. Use the bi-link straps (supplied in accessories) to connect the treble and mid-range terminals. Connect the cables between the amplifier and the loudspeakers as indicated and re-tighten all the terminals securely.

Note: Some amplifiers have two pairs of output terminals to facilitate bi-wiring but this is not essential. The advantages of bi-wiring are fully retained if your amplifier has only one pair of output terminals per channel (as in the illustration).

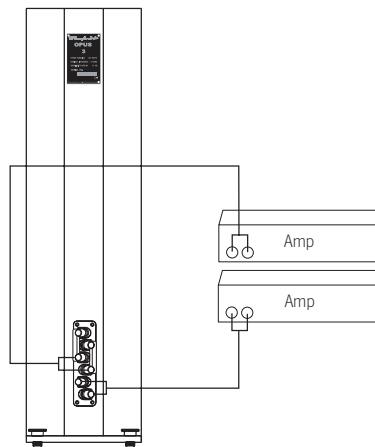

Tri or Bi-amplified - two or three amplifiers. One drives each section or 2 sections with Bi-wire link e.g mid/hf. (Remove all link sections when Tri-Amping)

Important Note, please make sure that heavy multi-standard cables are well connected and clamped. Single loose strands arcing can cause noise in the woofers like a faulty speaker.

THE HOME THEATRE ENVIRONMENT

Front and Effects Channels

The front loudspeakers are placed on either side of the television screen, 2 to 3 metres apart. The speakers should be angled slightly so they are aimed towards the listeners.

As the rear surround channels are the 'effects' channels the reproduced sound should be as room filling as possible. We recommend placing the speakers in a high position, behind the listeners head. If the rear wall is more than 1 metre behind the listening seat, position the units on the side walls. If the walls are a long way from the listening seat, consider stand mounting the loudspeakers.

Most of the dialogue comes from the centre loudspeaker. Speech should appear to originate from the actors mouths. Operating height is important. Ideally the front and centre channel speakers should be at the same height. For this reason the centre channel speaker is best operated above the television monitor.

The OPUS Tri-Centre Loudspeaker

The loudspeaker should be positioned centrally between the loudspeakers close to the television and mounted either above or below the screen.

The loudspeaker should be located on a stable flat surface to avoid any danger of the cabinet moving when it is vibrated by high sound levels. If you mount the unit on top of the television, move it forward so that the front grilles are level with or slightly in front of the screen. This will reduce reflections from the screen and the top of the cabinet.

Although you can place the centre channel loudspeaker under the TV monitor, this should be regarded as a second best. The preferred position is always above the monitor.

The OPUS Tri-Surround Loudspeaker

Connect the cable to the speaker. The speaker should ideally be sited 600mm - 1.5 metres above the listening position and 2.5 - 3.5 metres apart, central to the listener and behind the listening position, preferably on a rear wall. If the listening position is some distance from a rear wall, the loudspeakers may be mounted on opposite side walls but always behind the listening position.

Ensure that the wall is strong and can support the product. Drill two 5mm holes in the wall 160mm apart and horizontally aligned. Fix a suitable No 8 round head screw firmly into each hole using appropriate wall plugs.

Leave a stub of 5mm protruding from the wall. Align the holes in the mounting brackets over the screw heads and carefully lower the unit onto the screws. The speaker can now be securely attached with the spacers resting against the wall. Now connect the speakers to the amplifier before final mounting of the surrounds.

System with Rear Mounted Tri Surrounds

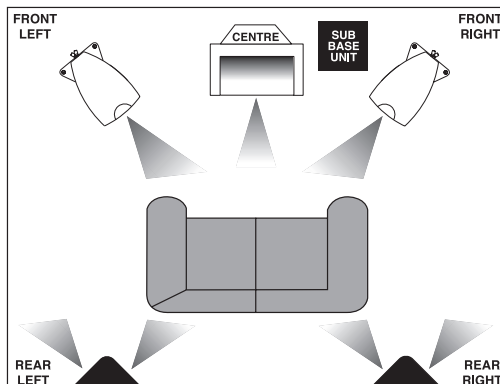

System with Side Mounted Tri Surrounds

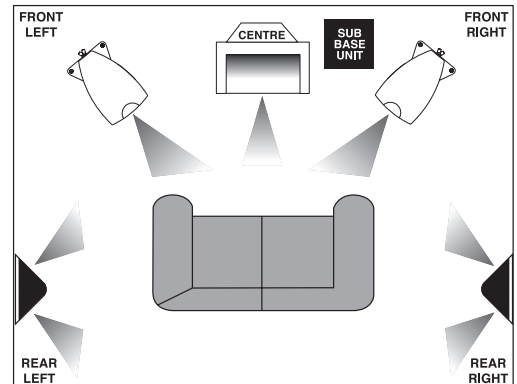

Subwoofer

As the ear is unable to detect the direction from which deep bass originates, this allows you freedom to position a subwoofer according to the level of bass required. Placing the subwoofer near a corner or particularly close to a wall will boost the bass but may impair clarity. The performance of Home Theatre systems can often be enhanced by using a pair of subwoofers.

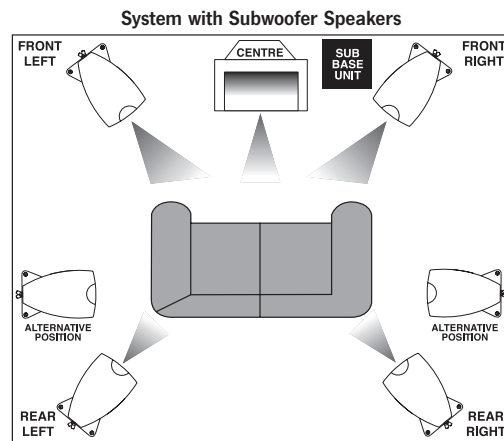

OPUS Centre Loudspeaker

A set of self adhesive pads is provided. Peel off the backing material and fix a pad close to each corner of the bottom surface of the loudspeaker.

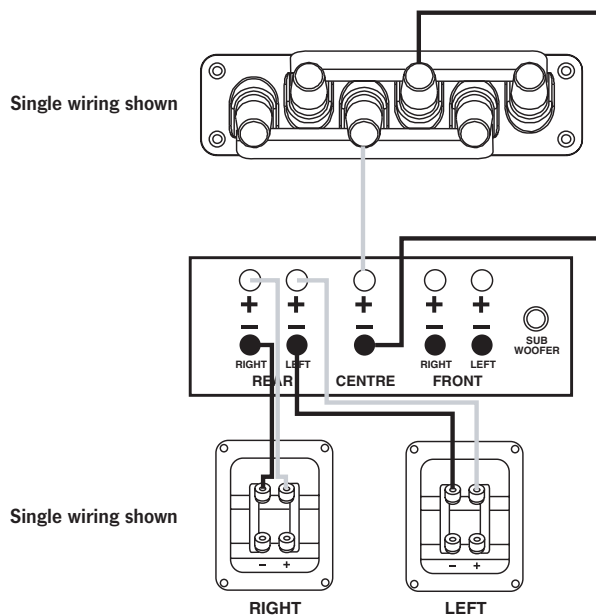

OPUS Surround Loudspeaker

Four self adhesive spaces are provided with each unit. Attach one close to each rear corner of the cabinet. This speaker is designed primarily for wall mounting – please see separate section for this topic.

Setting Loudspeaker Sizes

Many digital AV Processors require you to specify the size of speakers in all channels. These are usually 'Large or small'. For Opus set the front speakers to 'large', set the centre to 'large' and the surrounds to small. The subwoofer then will reproduce only the LFE bass signals.

If you are not using a subwoofer: Set the front speakers to set the subwoofer option on the processor to 'Off' or 'No'. The front channels will now receive all the system bass.

(If you are using a subwoofer: When front speakers are set to small the bass for these channels will pass into the subwoofer. If you choose large for the front channels, bass will be reproduced from the front speakers and the sub will just control the LFE channel).

Setting Levels

Once the loudspeaker settings have been finalised, put the AV amplifier into its "test" mode (see instructions supplied with your processor). Adjust the level of each channel in turn until all channels are reproduced at equal loudness.

On some programme material the surround channel may seem lower than the front. Do not readjust this level. You may, however, need to adjust the subwoofer output level. Avoid setting too high a level or you will swamp the sound with bass. This can be tiring to listen to, and may limit the subwoofer's ability to respond to large bass transients. You should also set a sensible level going into the subwoofer from the AV processor.

Delay Settings

Many AV processors feature delay settings. The purpose of delay is to enable surround and dialogue information to arrive at the listener's ears at the same time as the front channels, even when the listening seat is in a non-ideal position. On some processors, this can be achieved by setting the distance from the listening position to each speaker in turn, but other systems allow only a time delay setting.

Rear Delay: If the listening position is equidistant from the front and rear speakers, a low delay setting should be set. The closer the listener is to the rear speakers the higher the delay setting used should be.

Centre Delay: If the centre speaker is level with (or slightly behind) the front speakers, set the delay to zero. If the centre speaker is forward of the front speakers, increase the delay.

LFE

In the cinema the low frequency effects channel is an extra bass channel with its own subwoofer and not a regular subwoofer channel. In domestic systems the LFE channel typically feeds into the subwoofer. Where no subwoofer is used, the LFE signal is combined with front channel information and sent to the front speakers. When you set the LFE level at your AV processor, use care as the powerful low frequencies can overload domestic loudspeakers.

If you hear popping or thumping noises coming from the front loudspeakers or subwoofer, immediately turn the AV Processor's volume level down and then lower the LFE level. This should cure the problem. If it does not, lower the volume level at the subwoofer (if you are using one) until the problem disappears. Please read the relevant sections of your AV amplifier manual and familiarise yourself with the various issues. If you are unsure, consult your dealer for help.

Phase

A home theatre system should have a precise front stage, a diffuse rear stage and good localisation of dialogue. If the colours on the loudspeaker terminals do not correspond with those on the amplifier, the sound will appear poorly focussed or 'Out of phase'. For this reason it is essential that the speakers are connected accordingly to the wiring diagrams in this manual.

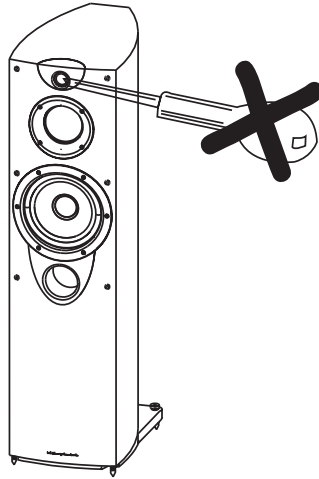

Do not open the speakers; there are no user serviceable parts inside.

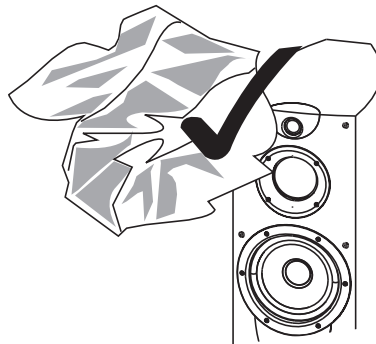

Remove marks from the cabinet and polish it with a soft, slightly damp cloth.

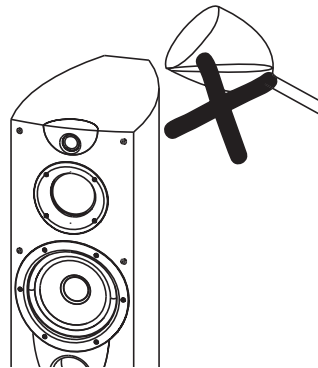

Avoid getting any liquid behind the grille.

TECHNICAL SUPPORT AND INFORMATION

For technical support, servicing or product queries and information please contact either your local retailer or the offices below.

UK

Wharfedale International Ltd.
IAG House, Sovereign Court,
Ermine Business Park,
Huntingdon. PE29 6XU
England
Tel : +44 (0) 1480 447700
Fax : +44 (0) 1480 431767
www.wharfedale.co.uk

USA

IAG America, Inc.
15 Walpole Park South,
Walpole,
MA 02081
USA
Tel: +1 (0) 508 8503950
Fax: +1 (0) 508 8503905
www.iagamerica.com

ASIA

Room 2310 - 2311 Press Building,
Shennan Road C,
Shenzhen,
China
Tel: +86-755-82091200
Fax: +86-755-82091205

..... ABOUT YOUR LOUDSPEAKER

'THE OPUS SERIES'

The OPUS is a new series of loudspeakers. They are large format loudspeakers, utilising multiple drive units.

The loudspeaker meets the demands of the most discerning audiophile.

These 3 way loudspeakers exhibit exceptional performance characteristics based upon the following concepts.

- Very low distortion across the entire audio band.
- Low excursion requirement of the cone drivers.
- High flux magnet systems enabling good dynamic response and impulse control.
- Broadband dispersion for excellent stereo image and staging.
- Careful attention to component design, operation, integration and acoustics.

THE CABINET

The enclosure of your speaker is finished to a high-quality furniture standard. Real wood veneers have been selected and carefully patterned matched by hand. Over a period of several days a high gloss 'Piano' finish has been achieved. This involves several coatings of lacquers being applied, each being cut and polished before the next coat is applied. Only through this time-consuming and skilled technique, can we achieve the necessary depth and lustre of gloss.

Instead of the usual cuboid shape of speaker cabinet, Opus is built with a beautiful curvaceous design, with a special purpose:- to reduce to negligible levels any internal cabinet standing waves and reflections. Parallel-sided tall boxes promote the creation of acoustic wave formation within the box by reflection up and down the length, these can add and subtract creating anomalies in the forward response. The multiple curved and braced interior of the Opus cabinet prevents this and results in a much clearer, more precise sound.

Skilfull engineering in 'MDF' or Medium Density Fibre Board, universally known to be one of the best enclosures materials, has resulted in an ideally shaped, very strong, internally multiple braced, low resonance structure.

THE DRIVE UNITS

THE BASS DRIVERS

The bass driver(s) incorporates a new design of cone utilising our own new bi-carbon weave process. Carbon fibre has immense longitudinal strength and is used in many structures where high strength and light weight are key attributes. Carbon fibre can be found liberally used in Formula 1 Racing Cars, Aeroplanes, Boats, Spacecraft and even Golf Clubs.

These bundles are woven and impregnated with special bonding resins that are subsequently pressure formed and heat cured. The resulting material is stiff, rigid and exhibits very low levels of internal resonance. Consequently, energy losses in the cone transfer mechanism are very low.

Similarly, lateral voice coil strength is very high. We use a combination of half hard aluminium and resin bonded glass fibre. This, in turn, contributes towards some of the lowest distortion figures ever seen in conventional drivers. The dust cap/cover is of the same material as the cone.

The bass drivers operate only over the low frequency range. They are only used over their true piston range. The cone is terminated with a conventional large half roll of synthetic butyl rubber with excellent inherent damping qualities.

A high performance traditional ferrite magnet system is used. Motional noise can be a problem with high output bass systems. We address this by moving air through vents in the voice coil. The magnet systems is also fully vented throughout.

THE 75mm 3" SOFT DOME MIDRANGE

A studio monitor quality large dome mid-range is used to cover the crucial midband frequencies. The key feature of this driver is exceptionally low distortion over its entire working range, typically less than 1% when producing 100dB at 1 metre. It is mounted in a custom matched fascia plate to provide partial horn loading and giving a broad angle of dispersion to its upper crossover point. The fascia plate is constructed from die cast aluminium, designed to place the units as close as possible for optimum integration and to create a point source effect. It has a large 75mm 3" voice coil again based on a rigid half hard aluminium former. The dome is pressure equalised by an underside baffle and chamber.

THE 25mm 1" SOFT DOME TWEETER

The highest frequencies are also handled by a soft dome driver. Our extensive research has proven these are a better choice than the metallic based domes that typically add their own character to the treble. A feature of the tweeters, as with the mids, is wide dispersion and very low distortion, again typically less than 1% at 100dB at 1 metre. The unit features a high flux neodymium magnet structure, producing a typical efficiency of 93dB 1W@1m. This unit has a frequency response extending far beyond audible frequencies to around 45kHz.

THE CROSSOVER AND WIRING

Monster Cable XP is used throughout the internal wiring (USA only - other countries use alternative brands of high-quality OFC cable). High quality printed circuit boards are used, and all connections are made to audiophile standards. All inductors used are air-cored and use large gauge wire for very low insertion loss. All capacitors used are either, low loss, low ERC polypropylene or high quality audio grade reversible electrolytics.

SPECIFICATIONS



	OPUS 1	OPUS 2
Transducer Complement	3 Way	3 Way
Cone Bass driver	8" 200mm	8" 200mm x 2
Soft Dome Mid-Range	3" 75mm	3" 75mm
Soft Dome Tweeter	1" 25mm	1" 25mm
Nominal impedance	6Ω	6Ω
Impedance variation (ohms)	4.2-40	4.5-37
Frequency response +/- 3dB	37Hz-44kHz	33Hz-44kHz
Low frequency limit -10dB	26Hz	24Hz
Upper frequency limit -10dB	45Hz	45Hz
SPL 1W @ 1m	89dB	90dB
Distortion 20 - 600Hz 100dB@1m	>3%	>3%
600 - 50kHz	>1%	>1%
Power Handling		
Continuous Programme	150 Watts	250 Watts
Recommended Amplifier Power	60-300W	100-500W
Max Peak SPL	109dB	115dB
Nominal coverage horizontal	90 to 14kHz	90 to 14kHz
Nominal coverage vertical	70 to 12kHz	70 to 12kHz
Enclosure type bass/mid	ported / sealed	ported / sealed
Volumes bass/mid	44 / 10 litres	54 / 10 litres
System Fb	40Hz	38Hz
Crossover frequencies	700Hz, 4kHz	700Hz, 4kHz
Construction material	18 & 33mm MDF	18 & 33mm MDF
Finish	Real wood veneers of Birds Eye Maple, Rosewood, Black, all in deep gloss piano finish	
Component part numbers		
Bass driver	2096	2097
Midrange speaker	0723	0723
Tweeter	0326	0334
Product dimensions H x W x D	995 x 260 x 410	1120 x 260 x 410
Net weight	25.5kg	29.5kg
Crate dimensions H x W x D	1120 x 380 x 550	1240 x 380 x 550
Gross weight	30.8kg	35.3kg



OPUS 3

TRI-CENTRE

TRI-SURROUND

3 Way
10" 250mm x 2
3" 75mm
1" 25mm
6Ω
4.0-28
30Hz-44kHz
23Hz
45Hz
91dB
>3%
>1%

3 Way
6.5" 170mm x 2
3" 75mm
1" 25mm
6Ω
4.5-24
75Hz-44kHz
70Hz
45Hz
89dB
20-200 >5%
200-45k >1%

3 Way
6.5" 170mm
3" 75mm x 2
1" 25mm x 2
6Ω
-
60Hz-44kHz
50Hz
45Hz
89dB
>3%
>1%

300 Watts
100-600W
116dB
90 to 14kHz
70 to 12kHz
ported / sealed
71 / 13 litres
35Hz
700Hz, 4kHz
18 & 34mm MDF

200 Watts
70-400W
113dB
80 to 12kHz
30 to 12kHz
sealed
25 litres
75Hz
900Hz, 4kHz
15 & 25mm MDF

100 Watts
40-200W
110dB
180 to 10kHz
90 to 12kHz
ported
12 litres
60Hz
700Hz, 3.5kHz
15mm MDF

2542
0723
0334

17104 x 2
0719
0334

17105
0723 x 2
0326 x 2

1195 x 315 x 440
34.4kg
1310 x 510 x 600
42.2kg

232 x 575 x 320
13.3kg
730 x 370 x 480
16.2kg

280 x 460 x 180
9.2kg
445 x 560 x 581
22.2kg (pair)

Wharfedale



	250mm 10"	200mm 8"	170mm 6.5"
Frame material	Aluminium/Steel	Aluminium/Steel	Aluminium/Steel
Cone & dome material	Woven carbon fibres	Woven carbon fibres	Woven carbon fibres
Surround	s r b p Single roll	s r b p Single roll	s r b p Single roll
Spiders	Single	Single	Single
Coil size & type	38mm Aluminium	38mm Aluminium	25mm Aluminium
Winding spec	2 layer round cu x 15mm	2 layer round cu x 10mm	2 layer round cu x 11mm
Magnet (D1 x D2 x H)	115 x 56 x 20 ferrite	115 x 56 x 20 ferrite	80 x 32 x 15 ferrite
Magnet weight	760gm	760gm	300gm
Gap flux density	1.1T	1.1 T	0.77 T
Top plate thickness	6mm	6mm	6mm
Optimum working range	25Hz - 500Hz	25Hz-800Hz	40Hz-1000Hz
Venting	Coil, pole	Coil, pole	Coil, pole
Thiele Small parameters			
Effective cone diameter	200mm	165mm	140mm
Re	8Ω	4.5Ω	15.5Ω
Fs	39Hz	39Hz	54Hz
Qms	3.12	2.31	3.33
Qes	1.08	0.57	1.35
Qts	0.8	0.45	0.96
Mms	38gm	29gm	17gm
Cms	0.43mm/N	0.55mm/N	0.49mm/N
Vas	59L	34L	16L
BL	8.38f/m	7.64t/m	8.26

MIDRANGE SPECIFICATIONS

Part number	0719 & 0723
Dome material & size	75mm textile
Coil size & type	75mm aluminium
Magnet d1 x d2 x h	70 x 32 x 15
Magnet weight	248gm
SPL 1w @ 1m	93dB
Fs	500Hz
Frequency range -3dB	400Hz-5kHz
Distortion at 100dB @ 1m	typically < 1%

TWEETER SPECIFICATIONS

Part number	0326 & 0334
Dome material & size	25mm textile
Coil size & type	25mm aluminium
Magnet d1 x h	25.4 x 4mm Neodymium
Magnet weight	14gm
SPL 1w @ 1m	92dB & 94dB
Fs	1 kHz
Frequency range -3dB	800Hz-40kHz
Upper frequency limit -10dB	45kHz
Distortion at 100dB @ 1m	typically < 1%

CROSSOVER SPECIFICATIONS

Crossover sections	3 way
Type	Butterworth
Wiring	Monster cable XP (USA only)
Connections	Amp/solder
Crossover points at -6dB	
Bass	400 & 900Hz
mid low	1000-1400Hz
mid high	3300-4000Hz
Tweeter	3300-4000Hz

opus-1

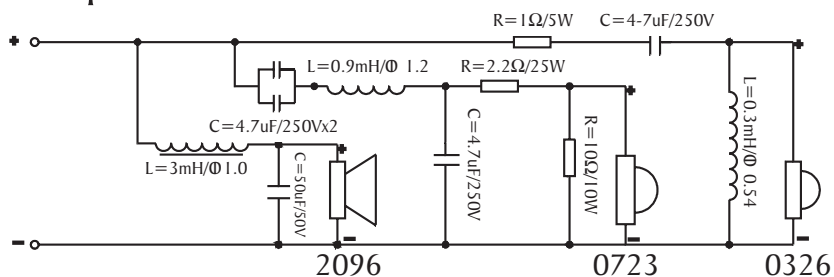

opus-2

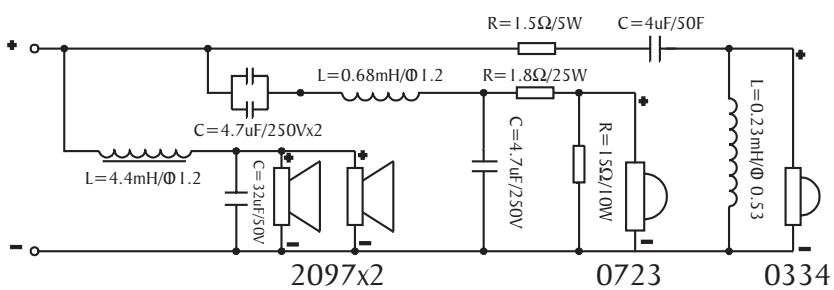

opus-3

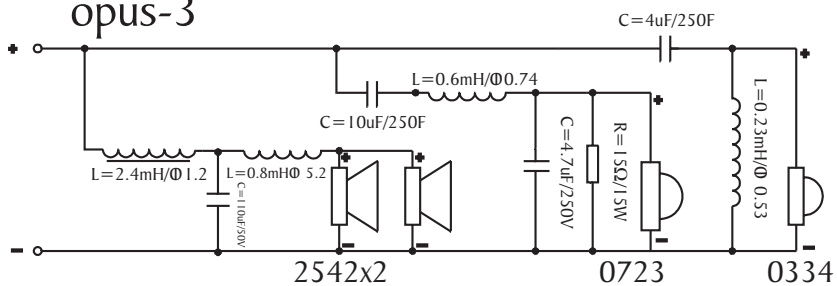

opus tri-centre

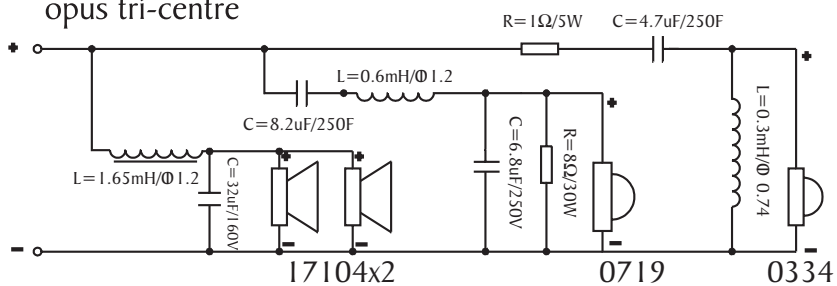

opus tri-surround

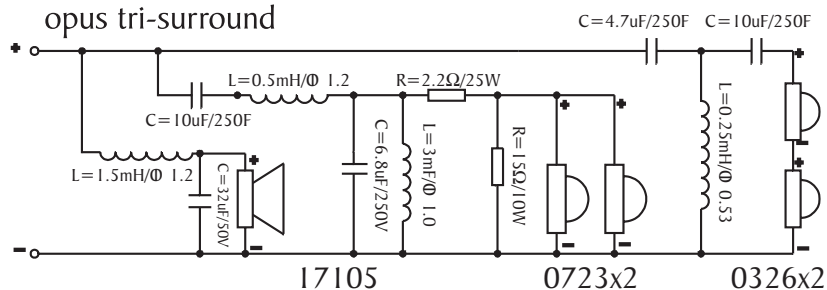

QUALITY MANAGEMENT

Your Opus loudspeakers have been constructed to the highest standards of quality throughout.

The acoustic components and the whole system have been manufactured to very tight tolerances of +/- 1 decibel of sound pressure level for each driver throughout the operation range of the unit.

All drive unit components are serially numbered and the original test record set for your loudspeakers is retained on file in our factory quality control department. This enables us to give an extended guarantee of identical replacement parts should they ever be required.

A copy of these test reports is included in the back of this manual. These should be retained for future reference.

A certificate of conformance to the original prototype specification, confirmed by the Opus designer and engineering director is included in this pack.



Wharfedale

Wharfedale International Ltd.

IAG House, Sovereign Court, Ermine Business Park, Huntingdon. PE29 6XU. England.

Tel : 0845 458 0011 / +44 (0) 1480 447700 Fax : +44 (0) 1480 431767

www.wharfedale.co.uk