

Proprietary Notice and Liability Disclaimer

The information disclosed in this document, including all designs and related materials, is the valuable property of NEC Computer Systems Division (hereinafter "NEC CSD") and/or its licensors. NEC CSD and/or its licensors, as appropriate, reserve all patent, copyright and other proprietary rights to this document, including all design, manufacturing, reproduction, use, and sales rights thereto, except to the extent said rights are expressly granted to others.

The NEC CSD product(s) discussed in this document are warranted in accordance with the terms of the Warranty Statement accompanying each product. However, actual performance of each such product is dependent upon factors such as system configuration, customer data, and operator control. Since implementation by customers of each product may vary, the suitability of specific product configurations and applications must be determined by the customer and is not warranted by NEC CSD.

To allow for design and specification improvements, the information in this document is subject to change at any time, without notice. Reproduction of this document or portions thereof without prior written approval of NEC CSD is prohibited.

Trademarks

INTEL is a registered trademark of Intel Corporation.

MS-DOS is a registered trademark of Microsoft Corporation.

Pentium is a registered trademark of Intel Corporation.

All other product, brand, or trade names used in this publication are the trademarks or registered trademarks of their respective trademark owners.

PN: 102173-02

November 1999
Copyright 1998, 1999
NEC Computer Systems Division
All Rights Reserved

Contents

| | |
|--|------------|
| Using This Guide | ix |
| Text Conventions..... | x |
| Related Documents..... | xi |
| Safety Notices..... | xii |
| Safety Notices for Users Outside of the U.S.A. and Canada..... | xiii |
| Care and Handling..... | xiv |
| | |
| System Overview | 1-1 |
| Overview | 1-2 |
| System Chassis | 1-5 |
| Power Supply..... | 1-7 |
| Peripheral Bays..... | 1-7 |
| SAF-TE Board..... | 1-7 |
| System Board Features | 1-8 |
| Pentium Processor | 1-9 |
| System Memory | 1-9 |
| I/O Expansion Slots..... | 1-10 |
| Real-Time Clock/Calendar..... | 1-11 |
| BIOS..... | 1-11 |
| IDE Controller..... | 1-11 |
| Network Controller..... | 1-11 |
| SCSI Controller | 1-12 |
| Video Controller..... | 1-12 |
| Peripheral Controller..... | 1-13 |
| Serial Ports..... | 1-13 |
| Parallel Port | 1-13 |
| External Device Connectors..... | 1-13 |
| System Board Management Controller (BMC)..... | 1-13 |
| System Security | 1-14 |
| Security with Mechanical Locks and Monitoring | 1-14 |
| Software Locks via the System Setup Utility..... | 1-14 |
| | |
| Setting Up the System | 2-1 |
| Overview | 2-2 |
| Selecting a Site | 2-2 |
| Unpacking the System..... | 2-3 |
| Rack-Mount Subsystem Assembly..... | 2-4 |
| Before You Begin..... | 2-4 |
| Static Precautions | 2-4 |
| Assembly | 2-5 |
| Getting Familiar with the System | 2-8 |
| Front View with Front Door Closed..... | 2-8 |
| Front View with Front Door Opened | 2-9 |
| Rear View..... | 2-11 |
| Status Indicator LED Descriptions..... | 2-12 |
| Making Connections..... | 2-14 |
| Setting the Line Voltage..... | 2-15 |
| Connecting the Power Cord(s) | 2-17 |

| | |
|-------------------------------|------|
| Powering On Your System | 2-17 |
|-------------------------------|------|

Configuring Your System.....3-1

| | |
|---|------|
| Configuring Your System | 3-2 |
| BIOS Setup Utility | 3-3 |
| Using the BIOS Setup Utility | 3-3 |
| BIOS Setup Configuration Settings | 3-4 |
| Main Menu..... | 3-5 |
| Primary IDE Master and Slave Submenu | 3-6 |
| Secondary IDE Master and Slave Submenu | 3-7 |
| Keyboard Submenu..... | 3-8 |
| Processor Settings Submenu | 3-8 |
| Advanced Menu..... | 3-9 |
| PCI Configuration Submenus | 3-10 |
| PCI Device, Slot 1 - Slot 4 Submenus | 3-10 |
| Integrated Peripheral Configuration Submenu | 3-11 |
| Advanced Chipset Control..... | 3-12 |
| Security Menu..... | 3-12 |
| Security menu (Continued)..... | 3-13 |
| Security menu (Continued)..... | 3-14 |
| Server Menu..... | 3-14 |
| System Management Submenu | 3-15 |
| Server Management Information Submenu | 3-16 |
| Console Redirection Submenu..... | 3-17 |
| Boot Menu | 3-17 |
| Boot Device Priority Submenu | 3-18 |
| Hard Drive Submenu | 3-18 |
| Removable Devices | 3-18 |
| Exit Menu | 3-19 |
| Symbios Configuration Utility..... | 3-20 |
| Running the Symbios Configuration Utility | 3-20 |
| Changing the Adapter and Device Configurations | 3-21 |
| Optional RAID Controllers..... | 3-24 |
| Factory Installed Controllers | 3-24 |
| Add-on Controller..... | 3-25 |
| DACCF Configuration Utility | 3-25 |
| Configuring System Board Jumpers | 3-26 |
| Before You Begin | 3-26 |
| Moving System Board Jumpers..... | 3-28 |
| Resetting the CMOS NVRAM | 3-29 |
| Clearing and Changing the Passwords..... | 3-29 |
| Recovering the BIOS | 3-29 |
| Boot Block Write Protect..... | 3-29 |
| Fault Resilient Booting (FRB) Timer Enable Jumper | 3-30 |
| Chassis Intrusion Detection Jumper | 3-31 |
| BMC Forced Update Mode | 3-31 |

| | |
|--|------------|
| Upgrading Your System | 1 |
| General Information | 2 |
| Static Precautions | 2 |
| Preparing Your System for Upgrade | 3 |
| Equipment Log | 3 |
| Opening the Front Door..... | 3 |
| Removing a Side Panel..... | 4 |
| Installing a Side Panel | 5 |
| Modifying the System Board..... | 6 |
| Replacing the Real-time Clock Battery..... | 6 |
| Replacing a Pentium Processor | 8 |
| Removing the Pentium II Processor (S.E.C. Version)..... | 9 |
| Installing the Pentium II Processor (S.E.C. Version) | 10 |
| Replacing the Pentium III Processor (SECC2 Version)..... | 12 |
| Removing and Installing the Cooling Baffle..... | 14 |
| DIMMs | 15 |
| Memory DIMM Configurations | 16 |
| Installing DIMMs | 17 |
| Removing DIMMs..... | 18 |
| Option Boards..... | 19 |
| Installation Considerations | 19 |
| Installing an Option Board | 20 |
| Removing an Option Board..... | 23 |
| Installing a RAID Controller Board | 23 |
| Hard Disk Drives..... | 24 |
| Installing or Swapping a Hard Disk Drive in a Hot-swap Bay | 25 |
| Installing or Swapping a Hard Disk Drive | 26 |
| Removable Media Devices..... | 29 |
| Installing a 5.25-Inch Media Device | 30 |
| Removing a 5.25-Inch Device..... | 35 |
| | |
| Problem Solving..... | 5-1 |
| Problem Solving | 5-2 |
| Static Precautions | 5-2 |
| Troubleshooting Checklists | 5-3 |
| Initial System Startup..... | 5-3 |
| Running New Application Software | 5-4 |
| After System Has Been Running Correctly..... | 5-5 |
| Additional Troubleshooting Procedures..... | 5-6 |
| Preparing the System for Diagnostic Testing..... | 5-6 |
| Monitoring POST | 5-7 |
| Verifying Proper Operation of Key System Indicators | 5-8 |
| Confirming Loading of the Operating System | 5-8 |
| Specific Problems and Corrective Actions | 5-9 |
| Power LED Does Not Light | 5-9 |
| Incorrect or No Beep Code..... | 5-10 |
| No Characters Appear on Screen | 5-10 |
| Characters are Distorted or Incorrect | 5-11 |
| System Cooling Fans Do Not Rotate | 5-11 |
| Diskette Drive Activity LED Does Not Light..... | 5-11 |
| CD-ROM Drive Activity Light Does Not Light | 5-12 |

| | |
|---|------|
| Problems with Application Software..... | 5-12 |
| Press F2 Key to Enter Setup: Prompt Does Not Display..... | 5-12 |
| Enable F2 Prompt by Using SSU..... | 5-13 |
| Enable F2 Prompt by Changing a Jumper and Using SSU..... | 5-14 |
| Bootable CD-ROM Is Not Detected..... | 5-14 |
| Problems with the Network..... | 5-15 |
| PNP Installation Tips..... | 5-16 |
| BIOS User's Information..... | 5-16 |
| Error and Status Messages..... | 5-16 |
| POST Error Codes and Messages..... | 5-20 |
| How to Identify BIOS and BMC Revision Levels..... | 5-22 |
| BIOS Revision Level Identification..... | 5-22 |
| BMC Revision Level Identification..... | 5-22 |

System Cabling..... A-1

| | |
|-----------------------------|-----|
| System Cabling..... | A-2 |
| Before You Begin..... | A-2 |
| Static Precautions..... | A-2 |
| Standard Configuration..... | A-3 |
| RAID Configuration..... | A-6 |

System Setup Utility..... B-1

| | |
|---|------|
| System Setup Utility (SSU)..... | B-2 |
| Creating SSU Diskettes..... | B-3 |
| Running the SSU..... | B-4 |
| Customizing the SSU..... | B-5 |
| Launching a Task..... | B-6 |
| Resource Configuration Add-in (RCA) Window..... | B-7 |
| Defining an ISA Card..... | B-8 |
| Adding and Removing ISA Cards..... | B-9 |
| Modifying Resources..... | B-10 |
| Recommended Resource Settings..... | B-11 |
| System Resource Usage..... | B-12 |
| Multiboot Add-in (MBA) Window..... | B-13 |
| Password Administration (PWA) Window..... | B-13 |
| System Event Log (SEL) Window..... | B-14 |
| Exiting the SSU..... | B-15 |

Emergency Management Port..... C-1

| | |
|--|------|
| Emergency Management Port..... | C-2 |
| How the EMP Works..... | C-3 |
| EMP Requirements and Configurations..... | C-5 |
| Setting Up the Server for the EMP..... | C-6 |
| System Management Submenu..... | C-6 |
| Console Redirection Submenu..... | C-7 |
| Main EMP Window..... | C-7 |
| Toolbar..... | C-7 |
| Status Bar..... | C-8 |
| EMP Main Menu..... | C-8 |
| Server Control Operations..... | C-9 |
| Connect..... | C-9 |
| Power On/Off..... | C-10 |

| | |
|--|------|
| Reset | C-11 |
| Phonebook | C-12 |
| Management Plug-ins | C-13 |
| SEL Viewer | C-13 |
| SEL Viewer Menu Options | C-14 |
| Sensor Type Codes | C-15 |
| Using the Sensor Type Code Table | C-15 |
| SDR Viewer | C-17 |
| SDR Viewer Menu Options..... | C-18 |
| FRU Viewer | C-18 |
| FRU Viewer Menu Options..... | C-19 |

System Status Hardware Support Information.....D-1

| | |
|--|-----|
| System Status Hardware Support Information | D-2 |
|--|-----|

Glossary

Equipment Log

Index

Using This Guide

The MC2400 User's Guide provides a quick reference to information about your system. Its goal is to familiarize you with your system and the tasks necessary for system configuring and upgrading.

This guide contains the following information:

- Chapter 1, “System Overview” provides an overview of your system and describes your system's major system components. See this chapter to familiarize yourself with your system.
- Chapter 2, “Setting Up Your System” tells you how to select a site, unpack the system, assemble the rack-mount subsystem, make cable connections, and power on your system.
- Chapter 3, “Configuring Your System” tells you how to configure the system and provides instructions for running the BIOS Setup Utility and the Symbios Configuration Utility, which is used to configure SCSI devices in your system. This chapter also provides information on system board jumper settings.
- Chapter 4, “Upgrades and Options” provides you with instructions for upgrading your system with an additional processor, optional memory, options cards, and peripheral devices.
- Chapter 5, “Problem Solving” contains helpful information for solving problems that might occur with your system.
- Appendix A, “System Cabling” includes cabling information for the two onboard SCSI controllers, the onboard IDE controllers, and the optional RAID controllers.
- Appendix B, “System Setup Utility” provides information for configuring onboard resources and add-in boards. It also provides information on viewing the system event log.
- Appendix C, “Emergency Management Port” provides information on a feature that provides an interface to the Emergency Management Port (EMP) Console Manager. This interface allows remote server management via a modem or direct connection.
- Appendix D, “System Status Hardware Support Information” helps you identify a system status hardware item indicated by one of several software monitoring components.
- “Glossary” defines the standard acronyms and technical terms used in this manual.
- “Equipment Log” provides you with a sample equipment log for documenting the system configuration and future updates you may make to your system.

Text Conventions

This guide uses the following text conventions.

Warnings, cautions, and notes have the following meanings:

WARNING

Warnings alert you to situations that could result in serious personal injury or loss of life.

CAUTION

Cautions indicate situations that can damage the system hardware or software.

 **Note:** Notes give important information about the material being described.

- Names of keyboard keys are printed as they appear on the keyboard. For example, **Ctrl**, **Alt**, or **Enter**.
- Text or keystrokes that you enter appear as boldface type. For example, type **abc123** and press **ENTER**.
- File names are printed in uppercase letters. For example, **AUTOEXEC.BAT**.

Related Documents

In addition to this guide, the following system documentation is included with your server either as electronic files on EXPRESSBUILDER or as paper copy shipped with your server.

- *System Release Notes*

Release Notes provide you with the latest information about your system. This information was not available to be included in your user's guide at the time it was developed and released.

- *Getting Started Sheet*

The Getting Started Sheet provides several easy-to-follow steps to become familiar with your server documentation and to complete your installation successfully.

- *Network Operating System Configuration Guide*

This guide contains supplemental instructions needed to install and configure your server Windows NT v4.0, Novell NetWare v3.12, Novell NetWare v4.11, Santa Cruz Operation (SCO) OpenServer Release 5.04, and UNIXWare 7.0 Network Operating Systems. This document is intended to complement the more detailed procedural documents available from the vendor of the network operating system.

Safety Notices



- **Caution:** To reduce the risk of electric shock which could cause personal injury, follow all safety notices. The symbols shown are used in your documentation and on your equipment to indicate safety hazards.
- **Warning:** Lithium batteries can be dangerous. Improper handling of lithium batteries may result in an explosion. Dispose of lithium batteries as required by local ordinance or as normal waste if no local ordinance exists.
- **Warning:** The detachable power supply cords are intended to serve as the disconnect devices.
- **Warning:** This equipment has a 3-wire, grounded power cords. To prevent electrical hazards, do not remove or defeat the ground prong on the power cords. Replace a power cord if it gets damaged. Contact your dealer for an exact replacement.
- **Warning:** The DC push-button on/off switch on the front panel does not turn off the system AC power. Also, +5vdc is present on the system board whenever the AC power cords are connected between the system and an AC outlet. Before doing the procedures in this manual, make sure that your system is powered off and unplug the AC power cords from the back of the chassis. Failure to disconnect power before opening your system can result in personal injury and equipment damage.

In the U.S.A. and Canada, the power cord must be a UL-listed detachable power cord (in Canada, CSA-certified), type ST or SJT, 16 AWG, 3-conductor, provided with a molded-on NEMA type 5-15 P plug cap at one end and a molded-on cord connector body at the other end. The cord length must not exceed 9 feet (2.7 meters).

Outside the U.S.A. and Canada, the plug must be rated for 250 VAC, 10 amp minimum, and must display an international agency approval marking. The cord must be suitable for use in the end-user country. Consult your dealer or the local electrical authorities if you are unsure of the type of power cord to use in your country. The voltage change occurs via a switch in the power supply.

- **Warning:** Under no circumstances should the user attempt to disassemble the power supply. The power supply has no user-replaceable parts. Inside the power supply are hazardous voltages that can cause serious personal injury. A defective power supply must be returned to your dealer.

Safety Notices for Users Outside of the U.S.A. and Canada

- **PELV (Protected Extra-Low Voltage) Integrity:** To ensure the extra-low voltage integrity of the equipment, connect only equipment with mains-protected electrically-compatible circuits to the external ports.
- **Remote Earths:** To prevent electrical shock, connect all local (individual office) computers and computer support equipment to the same electrical circuit of the building wiring. If you are unsure, check the building wiring to avoid remote earth conditions.
- **Earth Bonding:** For safe operation, only connect the equipment to a building supply that is in accordance with current wiring regulations in your country. In the U.K., those regulations are the IEE.

Care and Handling

Use the following guidelines to properly handle and care for your system.

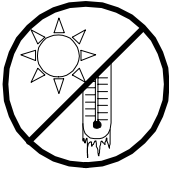

Protect the system from extremely low or high temperatures. Let the system warm (or cool) to room temperature before using it.



Keep the system away from magnetic forces.



Keep the system dry. Do not wash the system with a wet cloth or pour fluid into it.

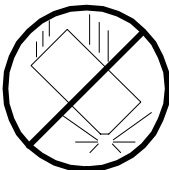

Protect the system from being bumped or dropped.



Check the system for condensation. If condensation exists, allow it to evaporate before powering on the system.



Keep the system away from dust, sand, and dirt.

1

System Overview

- Overview
- System Chassis
- Power Supply
- Peripheral Bays
- SAF-TE (SCSI Accessed Fault Tolerant Enclosure) Board
- System Board Features
- System Security

Overview

This server is a modular, multiprocessing server based on the Intel® Pentium® chip set. The combination of compute performance, memory capacity, and integrated I/O provides a high performance environment for many server market applications. These range from large corporations supporting remote offices to small companies looking to obtain basic connectivity capability such as file and print services, e-mail, web access, web site server, etc.

This server is also conveniently housed and available as a tower-based system or as a rack-mount system (fits into a standard IAE 19-inch rack assembly).

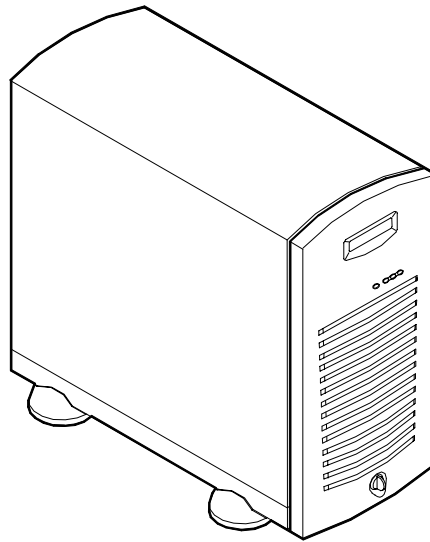

Tower-Based System Front View

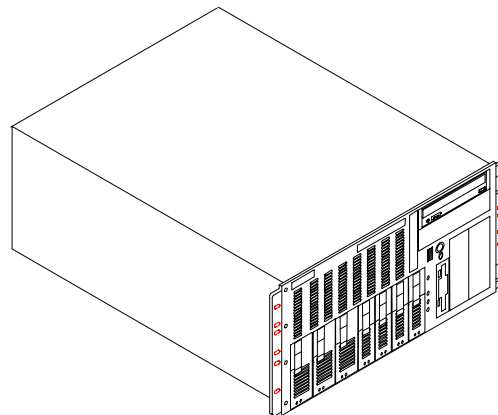

Rack-Mount System Front View

This server system is designed for minimum downtime. To this end, the server includes or has the options to include the following:

- Optional power system redundancy; in a system configured with two power supplies, the system will continue to operate with a single power supply failure.
- Self-contained power supply units that can be easily installed or removed from the back of the chassis.
- SCSI drive bays accessible from the front of the chassis.
- Hot-swap SCSI disk drive backplane; a failed drive can be removed and a new drive installed without system power being turned off, if an optional Redundant Array of Independent Disks (RAID) controller is installed.
- High degree of SCSI disk fault tolerance and advanced disk array management features through the use of RAID technology, if an optional RAID controller is installed.
- Chassis that supports up to two power supplies. The second power supply can be added to provide redundant power.

As application requirements increase, you can expand your server with an additional processor, additional memory, add-in boards and peripheral devices: tape devices, CD-ROM, diskette drives and hard disk drives.

Your server features the following major components:

- Single or dual high-performance Pentium processors packaged in Single Edge Connector (SEC) cartridges.
- 32 MB to 1 GB of memory, using up to four DIMMs.
- Four PCI expansion slots for add-in boards (one slot shared with an ISA slot). 1x32 bit PCI bus.
- Two ISA expansion slots for add-in boards (one slot shared with a PCI slot). Embedded PC-compatible support (serial, parallel, mouse, keyboard, diskette, and Plug and Play features).
- Integrated onboard Cirrus Logic CL-GD5480 Super Video Graphics Array (SVGA) controller with 2 MB of video memory.
- Dual Symbios SYM53C875 SCSI controllers providing ultra wide and legacy narrow SCSI interfaces.
- Integrated onboard Network Interface Controller (NIC), an Intel 82558 PCI LAN controller for 10 or 100 Mbps TX Fast Ethernet networks. RJ-45 Ethernet connector.
- Dual Channel enhanced IDE controller.
- Chassis that holds up to 12 drives: seven hot-swap bays for ultra-2 (LVD) SCSI hard drives; five removable media expansion bays with a CD-ROM reader already installed in one bay; and a half-height bay with a diskette drive already installed in the bay.
- Seven hot-swap SCSI hard disk drive bays accessible from the front of the chassis. The bays are secured behind a lockable front door where the drives can be swapped in or out of the system without powering it down, if RAID is configured in the system.
- SCSI backplane is Ultra-2 (LVD) ready.
- Integrated dual Universal Serial Bus (USB) ports.
- One standard power supply module with a slot available for an additional redundant power supply module. When an additional power supply module is installed, both the standard and additional redundant power supply module slots become hot swappable.
- Hardware monitors (temperature, fans, and voltage) and software monitors to indicate failures.

- Mechanical: Keylock at the front of the chassis and two metal padlocks loops (one at the back of each side panel). Three intrusion sensor switches for the front, left and right side of the chassis. Two of the three intrusion sensor switches (left and right side intrusion sensor switches only) become power inter-lock switches when two power supplies are installed.

System Chassis

The system chassis is an easy-to-expand, fabricated metal structure. The major system components are shown in the following illustrations.

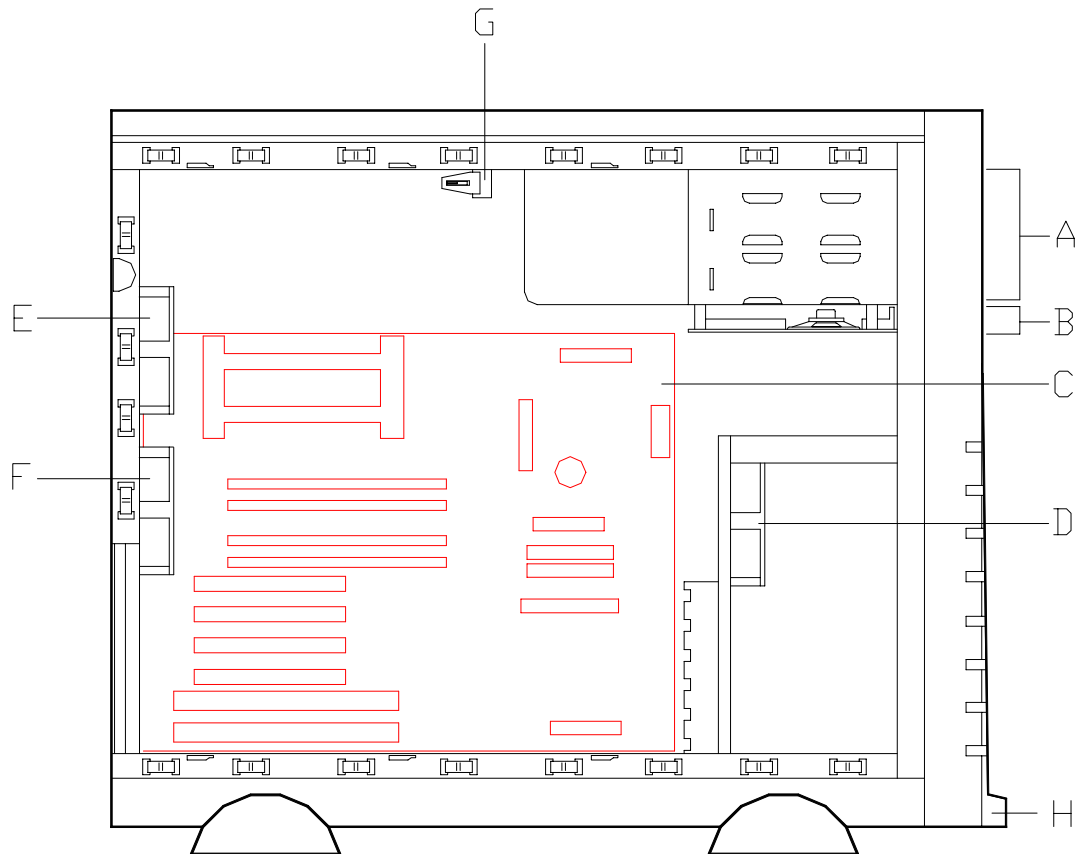

System Chassis (Left Side View)

- A. Removable media bays (2)
- B. Speaker/Switch assembly
- C. System board
- D. Front input fan
- E. Rear exhaust fan
- F. Second rear exhaust fan (Optional)
- G. Intrusion/Interlock switch - Side Covers
- H. Intrusion switch - Front Cover

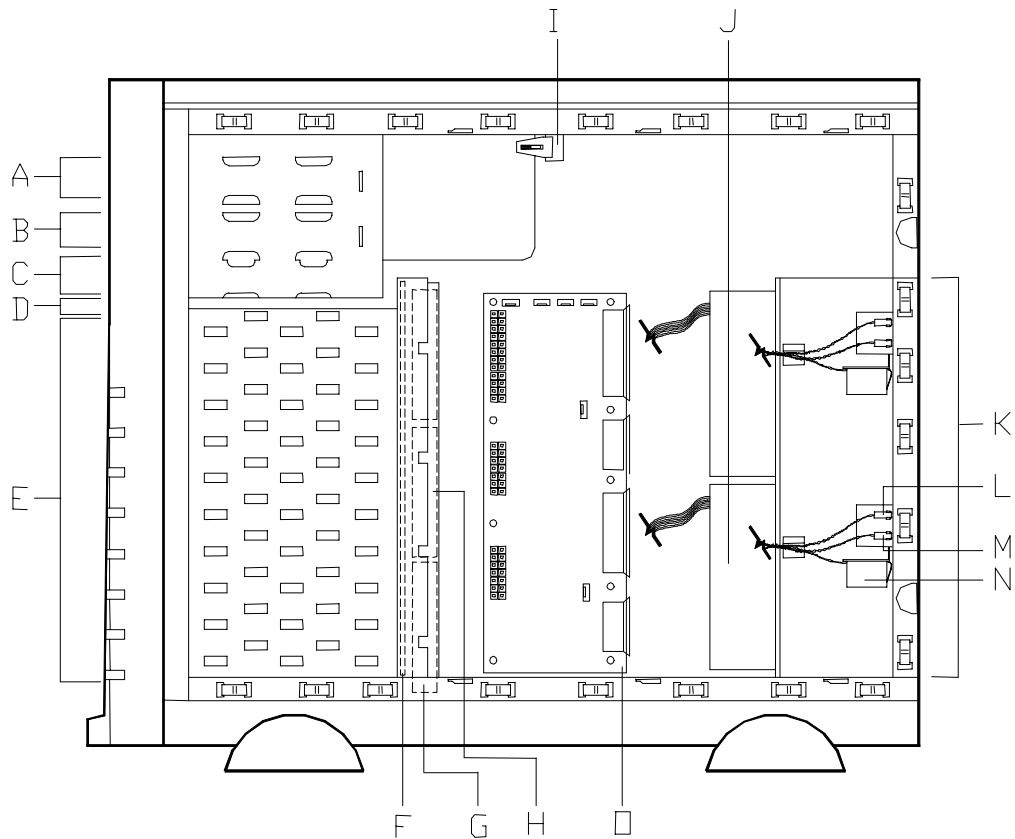

System Chassis (Right Side View)

- A. CD-ROM drive
- B. Removable media bay
- C. 1.44 MB 3.5" diskette drive
- D. SAF-TE board
- E. SCSI disk drive bays (7)
- F. SCSI backplane board
- G. Fans, behind SCSI disk drive bays (2 standard plus 1 optional)
- H. Optional fan*
- I. Intrusion/Interlock switch
- J. Standard power supply
- K. Power supply module slots (one standard power supply slot and one optional power supply slot)
- L. Power supply status LED*
- M. DC power LED*
- N. Power available switch*
- O. Power supply distribution board*

*Part provided with optional power supply kit.

Power Supply

The ATX300 watt power supply is switch-selectable for 115 or 230 Vac at an operating frequency of 50/60 Hz. It is designed to comply with existing emission standards and provides sufficient power for a fully loaded system configuration. The power supply voltage selection switch is factory set to 115Vac for systems used in the United States; it is set to 230Vac for systems used in Europe.

Peripheral Bays

The system supports a variety of standard PC AT-compatible peripheral devices. The chassis includes these peripheral bays:

- A 3.5-inch front panel bay for mounting the standard 3.5" diskette drive (supports 720 KB and 1.44 MB diskette media)
- Four 5.25-inch removable media front panel bays for mounting half-height 5.25-inch peripheral devices: standard CD ROM drive and optional tape drives, etc.
- Seven hot-swap SCSI hard disk drive bays for mounting up to seven SCSI hard disk drives in easily removable drive carriers.

 **Note:** The SCSI hard disk drive bays contain a hot-swap back plane that require an 80-pin single connector attachment (SCA) connector on the drives that you install.

SAF-TE Board

The system has a SAF-TE (SCSI Accessed Fault Tolerant Enclosure) board that provides an interface for the disk subsystem to automatically integrate with peripheral packaging that supports status signals, hot swapping drives, and enclosure monitoring.

The transport mechanism for the standardized alert detection and status reporting is the SCSI bus. Disk drives, power supplies, cooling fans, and temperature are continually monitored and the conditions then reported over the SCSI bus to the system. When used with RAID management software the user can be alerted of impending or imminent disk conditions requiring attention. This allows the user to react to conditions that could normally go unnoticed until data loss.

System Board Features

The system board offers a “flat” design with the processor and memory subsystems residing on the board. This figure shows the major components on the system board. The following subsections describe the system board major components.

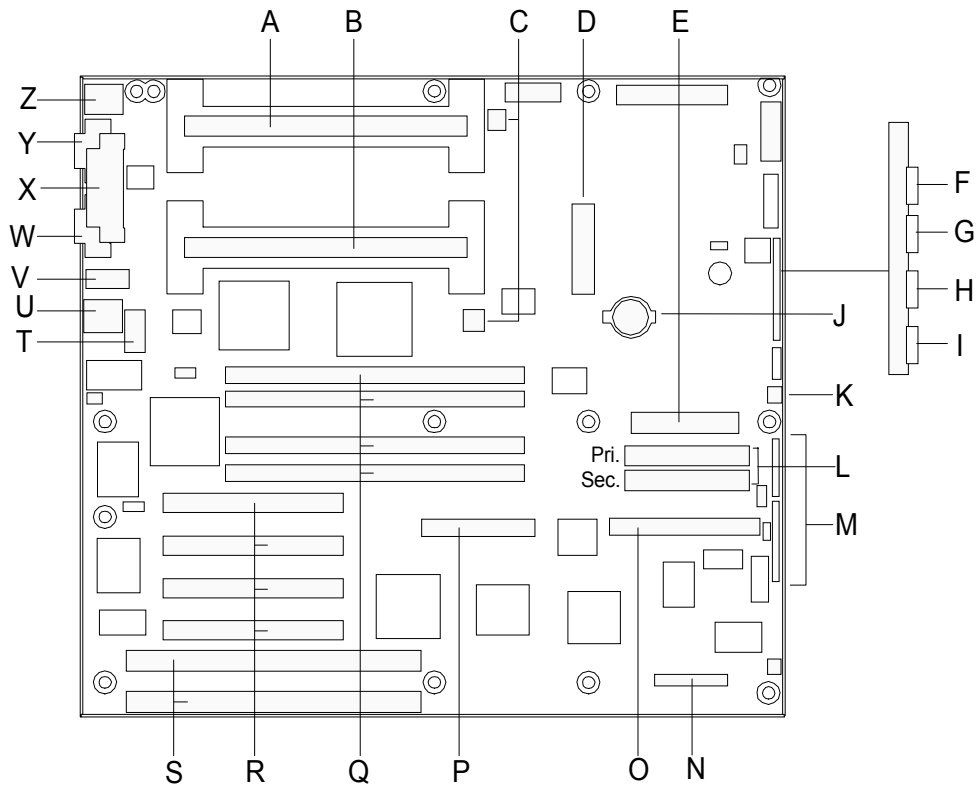

System Board

- | | |
|--|--|
| A. Secondary processor connector | N. Server management connector |
| B. Primary processor connector | O. Narrow SCSI connector |
| C. Fan connectors | P. Wide SCSI connector |
| D. Main power connector | Q. Memory DIMM sockets |
| E. Diskette drive connector | R. PCI slots for add-in boards |
| F. Front panel reset connector | S. ISA slots for add-in boards |
| G. Speaker connector | T. USB connector |
| H. Not used | U. RJ-45 network controller connector |
| I. Front panel power switch connector | V. Serial port B (COM 2) connector |
| J. Lithium backup battery | W. VGA monitor port connector |
| K. System fan connector | X. Parallel port connector |
| L. IDE connectors, primary and secondary | Y. Serial A (COM 1) connector |
| M. Configuration jumper blocks | Z. Keyboard and Mouse PS/2 compatible connectors |

Pentium Processor

Depending on system configuration, each system includes one or two Pentium processors. Each Pentium processor is packaged in a Single Edge Contact (S.E.C.) cartridge, or Single Edge Contact Cartridge Version 2 (SECC2). The cartridge includes the processor core with an integrated 16 KB primary (L1) cache; the secondary (L2) cache; a thermal plate (not included in the SECC2); and a back cover. The processor implements the MMX™ technology and the processor's numeric coprocessor significantly increases the speed of floating-point operations.

The processor external interface operates at a maximum of 100 MHz. The second-level cache is located on the substrate of the processor cartridge. The cache includes burst pipelined synchronous static RAM (BSRAM). The L2 cache is offered in 512 KB configurations only, with error correcting code (ECC).

System Memory

The system board contains four 168-pin DIMM sockets. Memory is partitioned as four banks of SDRAM DIMMs, each providing 72 bits of noninterleaved memory (64-bit main memory plus ECC). Your system may include from 32 MB to 1 GB of memory, using up to four DIMMs.

System memory begins at address 0 and is continuous (flat addressing) up to the maximum amount of DRAM installed (exception: system memory is noncontiguous in the ranges defined as memory holes using configuration registers). The system supports both base (conventional) and extended memory.

I/O Expansion Slots

The server's expansion capabilities meet the needs of file and application servers for high performance I/O by providing a combination of PCI local bus and ISA connectors.

The system board has two full-length ISA bus connectors. One of the connectors shares a chassis expansion slot with a PCI connector. ISA features:

- Bus speed up to 8.33 MHz
- 16-bit memory addressing
- 8- or 16-bit data transfers
- Plug and Play ready.

The system board has four full-length PCI connectors. One of the connectors shares a chassis expansion slot with an ISA connector. PCI features:

- Bus speed up to 33 MHz
- 32-bit memory addressing
- 5 V signaling environment
- Burst transfers up to a peak of 264 MB/s
- 8-, 16-, or 32-bit data transfers
- Plug and Play ready
- Parity enabled.

Real-Time Clock/Calendar

The real-time clock provides system clock/calendar information stored in a non-volatile memory (NVRAM). The real-time clock battery provides power backup for the real-time clock.

BIOS

A BIOS and Setup Utility are located in the Flash EPROM on the system board and include support for system setup and PCI/ISA Plug-and-Play auto-configuration. A number of security, reliability, and management features also have been incorporated to meet vital server needs.

IDE Controller

The system includes a dual channel enhanced IDE interface controller. The controller has a primary and secondary connector located on the system board, each connector supporting a master and a slave device. The IDE controller provides support for the internally mounted CD-ROM and an optional tape device.

Network Controller

The system board includes a 10BASE-T/100BASE-TX network controller based on the Intel 82558 Fast Ethernet PCI Bus Controller. As a PCI bus master, the controller can burst data at up to 132 MB/sec. The controller contains two receive and transmit FIFO buffers that prevent data overruns or underruns while waiting for access to the PCI bus. The controller has the following:

- 32-bit PCI bus master interface (direct drive of bus), compatible with *PCI Bus Specification, Revision 2.1*
- Chained memory structure with improved dynamic transmit chaining for enhanced performance
- Programmable transmit threshold for improved bus utilization
- Early receive interrupt for concurrent processing of receive data
- On-chip counters for network management
- Autodetect and autoswitching for 10 or 100 Mbps network speeds
- Support for both 10 Mbps and 100 Mbps networks, capable of full or half duplex, with back-to-back transmit at 100 Mbps.

The network status LEDs on the system board indicate:

- Transmit/receive activity on the LAN
- Valid link to the LAN
- 10/100 Mbps transfer mode.

SCSI Controller

The system board includes an embedded dual Symbios Logic SYM53C875, PCI SCSI host adapter. The SYM53C875 contains two independent SCSI controllers that share a single PCI bus master interface. Internally, each controller is identical, capable of operations using either 8- or 16-bit SCSI providing 10 MB/s (Fast-10) or 20 MB/s (Fast-20) throughput, or 20 MB/s (Ultra) or 40 MB/s (Ultra-wide) throughput. As implemented on the system board, controller A attaches to an Ultra-2 SCSI backplane that supports up to seven Ultra-2 SCA drives. Controller B may be used to support SCSI devices in the removable media bays.

Video Controller

The system has a high-performance SVGA subsystem that supports the following:

- BIOS compatibility with VGA, EGA, CGA, Hercules Graphics, and MDA
- 2 MB of Video Random Access Memory (VRAM) video buffer
- 16-bit bus for high-speed display memory access
- Hardware accelerated bit block transfers (BITBLT)
- Display power management system
- Supports 72Hz refresh, non-interlaced at: 640x480, 800x600, 1024x768, or 1280x1024 resolutions
- Displays of up to 16M colors at 640x480 and 800x600 resolutions, 64K colors at 1024x768 resolutions and 256 colors at 1280x1024 resolutions.

Peripheral Controller

The advanced integrated peripheral controller supports two serial ports, one parallel port, diskette drive, PS/2-compatible keyboard and mouse, and integrated Real Time Clock (RTC). The system provides the connector interface for each port.

Serial Ports

Both serial ports are relocatable. Each serial port can be set to one of four different COM ports and can be enabled separately. When disabled, serial port interrupts are available to add-in boards.

Parallel Port

One IEEE 1284-compatible 25-pin bidirectional EPP (supporting levels 1.7 and 1.9) parallel port is provided. BIOS programming enables the parallel port and determines the port address and interrupt. When disabled, the interrupt is available to add-in boards.

External Device Connectors

The external I/O connectors provide support for a PS/2 compatible mouse and a keyboard, connectors for VGA monitor, 2 serial port connectors, a parallel port connector and two USB connections.

System Board Management Controller (BMC)

Server management is concentrated in the System Board Management Controller (BMC). The BMC and associated circuitry are powered from a 5Vdc standby voltage, which remains active when system power is switched off, but the ac power source is still on and connected.

The BMC supports the Emergency Management Port (EMP) Console, which allows remote server management via a modem or direct connection to a manager system. Events monitored by the manager system include over-temperature and over-voltage conditions, fan failure, or chassis intrusion.

Information on the Emergency Management Port (EMP) Console may be found in Appendix C of this User's Guide.

System Security

To help prevent unauthorized entry or use of the system, the system includes a full lockable front panel and Server Management software that monitors the system intrusion switches.

Security with Mechanical Locks and Monitoring

The front panel of the tower-based system contains a mechanical lock to prevent access to the front of the computer chassis. In addition, each side cover contains a padlock loop (padlock not provided) located on the rear of the chassis to prevent removal of the side covers and access to the inside of the computer chassis

The computer chassis includes an intrusion switch for the front cover and intrusion/interlock switches for both the left side and the right-side covers (as viewed from the front). When any these covers are opened, the switch transmits an alarm signal to the system board, where server management software processes the signal. The side cover switches also operate as interlock switches. That is if only one power supply module is installed the switches operate as intrusion switches or if two power supply modules are installed the switches operate as inter-lock switches controlling power shut down to the system for safety reasons.

Security with the rack-mount system is identical to the tower-based system stated above, except that there is no front cover associated with the rack-mount system.

Software Locks via the System Setup Utility

The BIOS Setup Utility and the System Setup Utility (SSU) provide a number of security features to prevent unauthorized or accidental access to the system. Once the security measures are enabled, access to the system is allowed only after the user enters the correct password(s). For example:

- Enable the keyboard lockout timer so that the server requires a password to reactivate the keyboard and mouse after a specified time-out period—1 to 120 minutes.
- Set and enable an administrative password.
- Set and enable a user password
- Set secure mode to prevent keyboard or mouse input and to prevent use of the front panel reset and power switches.
- Activate a hot-key combination to enter secure mode quickly.
- Disable writing to the diskette drive when secure mode is set.

2

Setting Up the System

- Overview
- Selecting a Site
- Unpacking the System
- Rack-Mount Subsystem Assembly
- Getting Familiar with the System
- Making Connections
- Setting the Line Voltage
- Connecting the Power Cord(s)
- Powering On Your System

Overview

This chapter describes how to select a site, unpack the system, make cable connections, and power on the tower-based or rack-mount system units. Also, provided are the instructions for assembling the rack-mount system unit.

Selecting a Site

The system operates reliably in a typical office environment. Choose a site that is:

- Near grounded, three-pronged power outlets.

 **Note:** For the United States and Canada, this means a NEMA 5-15R outlets for 100-120 VAC or NEMA 6-15R outlets for 200-240 VAC. For other international sites, this means three-pronged power outlets applicable for the electrical code of the region.

WARNING

Be sure the power service connection is through a properly grounded outlet.

CAUTION

When two power supplies are installed in the system the power plug from each of the power supplies must be plugged into the same common ground power outlets.

- Clean, dust-free, and well ventilated. Front and rear ventilating openings kept free of obstructions. Away from sources of heat, vibration or physical shock.
- Isolated from strong electromagnetic fields and electrical noise produced by electrical devices (such as air conditioners, large fans, large electric motors, radio and TV transmitters, and high-frequency security devices)
- Spacious enough to provide at least five inches (13 centimeters) behind the system and three inches (eight centimeters) on each side of the system for proper cooling, airflow, and cable clearance.
- Easily accessible for system maintenance and installation of system upgrades.

Unpacking the System

WARNING

Your system weighs approximately 65 pounds (29.25 kg). If your system contains numerous optional boards and peripheral devices, it will weigh more. To avoid personal injury, make sure you have someone help you lift or move the system.

When you receive your system, inspect the shipping containers prior to unpacking. If the shipping boxes are damaged, note the damage, and if possible, photograph it for reference. After removing the contents of the containers, keep the cartons and the packing materials. If the contents appear damaged when you unpack the boxes, file a damage claim with the carrier immediately.

Rack-Mount Subsystem Assembly

This section provides the instructions for assembling the rack-mount server unit into a standard IAE 19 inch rack cabinet.

Before You Begin

Before you begin, please review the following cautions, warnings, and general guidelines.

WARNING

Be sure that power to the system is turned off and unplugged. All voltage is removed only when the power cords are unplugged.

- Avoid excessive vibration and shock. Dropping an electronic component can cause serious damage.
- Do not disconnect or remove parts other than those specified in the procedure.
- Do not touch I/O connector pins.
- All screws are phillips-head, unless otherwise specified.
- On completion of any assembly or reassembly, perform a power-on test. If a fault occurs, verify that the assembly or reassembly was performed correctly. If the problem persists, see "Problem Solving" in Chapter 5.

Static Precautions

An electrostatic discharge (ESD) can damage disk drives, option boards, and other components. You can provide some ESD protection by wearing an antistatic wrist strap attached to chassis ground when handling system components.

Electronic devices can be easily damaged by static electricity. To prevent damage, keep them in their protective packaging when they are not installed in your system.

Assembly

This section describes how to assemble your rack-mount server unit into a standard IAE 19 inch rack cabinet.

 **CAUTION**

Ensure that the location of the rack-mount server unit does not create an unstable condition when installed in the rack cabinet.

1. Select an appropriate location in your rack cabinet for the rack-mount server unit. To improve rack stability, mount heavier items towards the bottom of the rack cabinet.

 **Note:** When planning your system configuration for the rack cabinet you should consider the length of the cables that interconnect system components.

2. Locate the two support brackets (D). Using four self tapping screws (E) supplied with the rack cabinet for each support bracket, attach the two support brackets to the vertical mounting rails (A and B) of the rack cabinet.
3. Install the four caged nuts (C) that secure the front of the rack-mount server unit to the rack cabinet. Position the caged nuts to align with the screw holes in the front bezel of the rack-mount server unit.

 **Note:** The caged nuts are secured into the vertical mounting rails of the rack cabinet by inserting one side of the nut into the slot and squeeze while pressing the opposite side until it snaps into place.

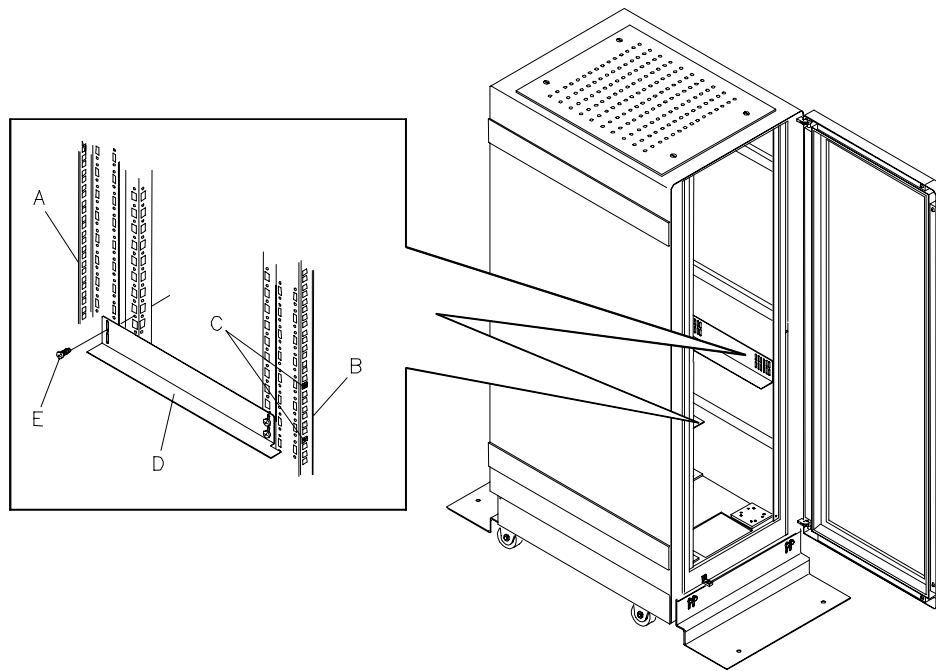

Assembling the Support Brackets in the Rack Cabinet

- A. Rear vertical mounting rail
- B. Front vertical mounting rail
- C. Four caged nuts
- D. Two support brackets
- E. Eight self-tapping screws

-
4. Lift the rack-mount server unit (C) onto the two support brackets and slide it toward the rear of the rack cabinet.

⚠ WARNING

It is strongly recommended that two people are present when lifting and assembling the rack-mount server unit into a rack cabinet.

5. Secure the front bezel to the rack cabinet's front vertical mounting rails (B) using the four screws (E) and plastic washers (D) provided.

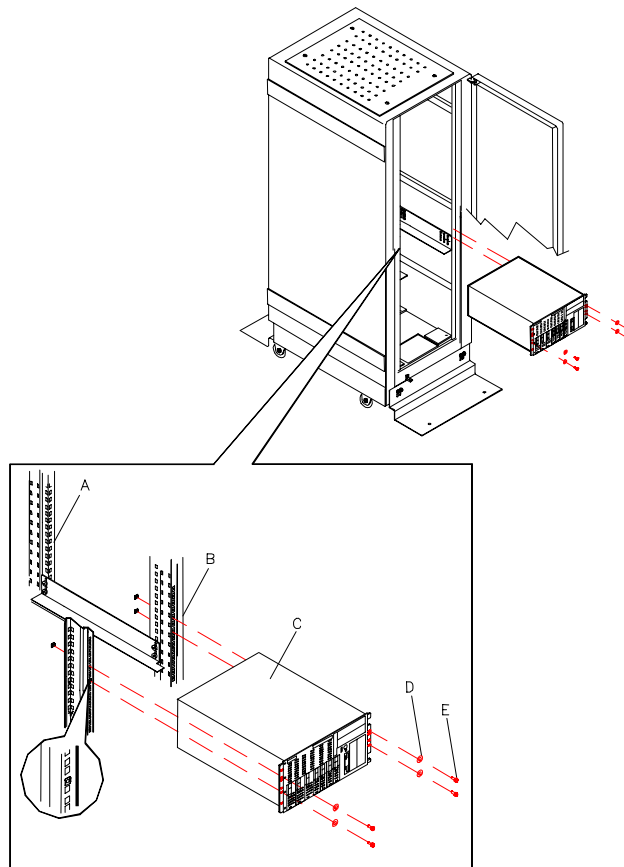

Installing the Rack-Mount Server Unit into the Rack Cabinet

- A. Rear vertical mounting rail
- B. Front vertical mounting rail
- C. Rack-mount server unit
- D. Four plastic washers
- E. Four screws

Getting Familiar with the System

Before setting up your system, you should become familiar with the system's features, such as the location of your system's front and rear panel switches, indicators and connectors, etc. Note that this section describes the tower-based system controls (switches and indicators) and connectors, which are identical for the rack-mount system.

Front View with Front Door Closed

This figure shows the location of the front system features (tower-based system only).

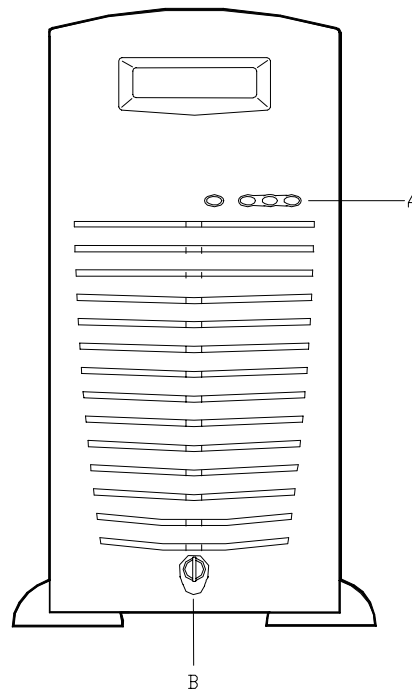

Front Features

- | | | |
|----|-------------------|---|
| A. | System indicators | (See "Front View with Front Door Opened" later in this chapter). |
| B. | Keylock | When locked, secures the front door not allowing access to the front system controls. |

Front View with Front Door Opened

Refer to the following figure and open the front door of the cabinet as follows (tower-based system only).

- 1.** If door is locked, unlock the front door.
- 2.** Pull the bottom of the front door out and tilt up until it is aligned level with the top of the cabinet, then push the door back directly over the top of the cabinet as far as it will go.

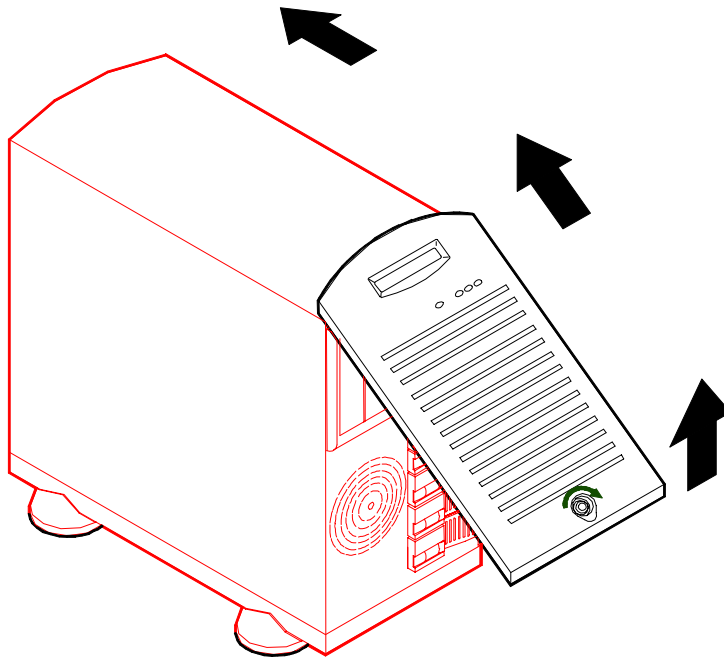

Opening the Front Door

This figure shows the location of the front system controls and indicators.

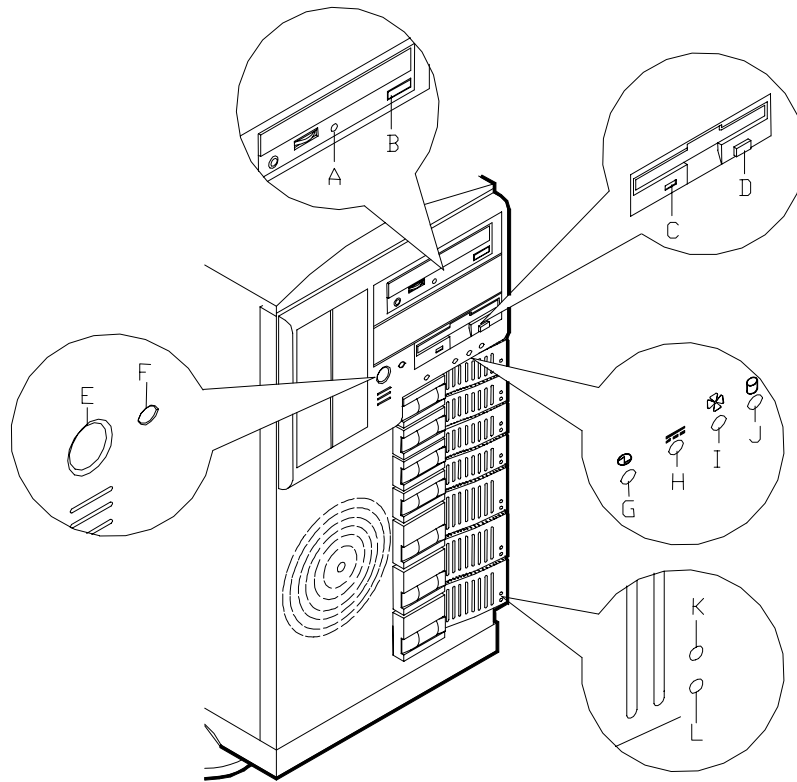

Front System Features and Controls

| | | |
|----|---|---|
| A. | Activity light, CD-ROM reader | When lit, CD-ROM reader is in use. |
| B. | Load/eject button, CD-ROM reader | Press to load CD and eject CD. |
| C. | Activity light, 3 1/2-inch diskette drive | When lit, diskette is in use. |
| D. | Eject button, 3 1/2-inch diskette drive | Press to eject diskette. |
| E. | DC power ON/OFF switch | Press to turn system DC power on or off. |
| F. | Reset switch | Press to reinitialize system. |
| G. | DC power ON/OFF | See table "Front System Status Indicator LEDs" that follow. |
| H. | Power alarm | See table "Front System Status Indicator LEDs" that follow. |
| I. | Fan alarm | See table "Front System Status Indicator LEDs" that follow. |
| J. | Array alarm | See table "Front System Status Indicator LEDs" that follow. |
| K. | Disk drive activity LED | See table "Disk Drive Status Indicator LEDs" that follow. |
| L. | Disk drive status LED | See table "Disk Drive Status Indicator LEDs" that follow. |

Rear View

This figure shows the location of the following rear system features and controls.

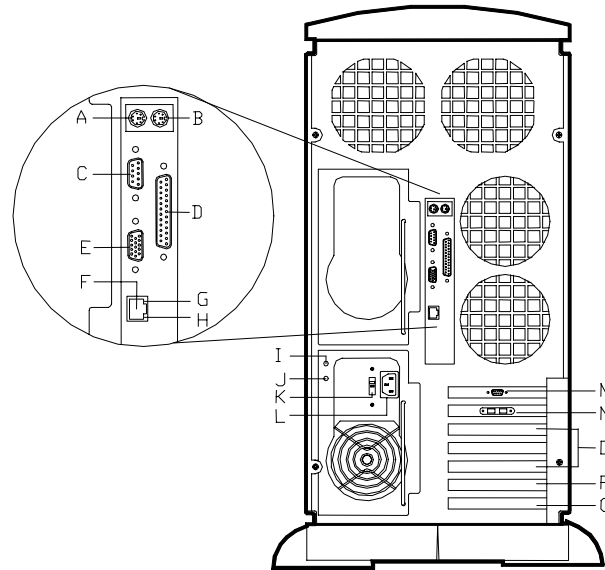

Rear Features and Controls

| | | |
|----|--------------------------------------|---|
| A. | Keyboard | PS/2-compatible 6-pin mini-DIN connector. |
| B. | Mouse | PS/2-compatible 6-pin mini-DIN connector. |
| C. | COM1 | COM1 serial port 9-pin connector. |
| D. | Printer | 25-pin parallel port connector. |
| E. | VGA | VGA monitor 15-pin connector. |
| F. | LAN connector | RJ-45 connector. |
| G. | Green LAN status light | See Table "LAN Status Indicator LEDs (I/O Panel)" that follows. |
| H. | Orange LAN status light | See Table "LAN Status Indicator LEDs (I/O Panel)" that follows. |
| I. | Power supply status (green light) | See Table "Power Supply Status Indicator LEDs (Rear Panel)" that follows. |
| J. | DC power status (amber light) | See Table "Power Supply Status Indicator LEDs (Rear Panel)" that follows. |
| K. | Line voltage selector switch | Selects AC input power of 115 VAC or 230 VAC. |
| L. | AC input power connector | Supplies AC power to the power supply. |
| M. | COM2 | COM2 serial port 9-pin connector. |
| N. | USB connectors | Two USB Connectors. |
| O. | PCI slots | Three PCI add-in board slot locations. |
| P. | Combo PCI/ISA slot | One PCI or ISA slot location. |
| Q. | ISA slot | One ISA add-in board slot locations. |

Status Indicator LED Descriptions

The following tables list the System Status Indicator LEDs, the Disk Drive Status Indicator LEDs, the Disk Drive Status Abnormal Conditions, the Power Supply Status Indicator LEDs, and the LAN Status Indicator LEDs along with a description of each LED indicator.

Front System Status Indicator LEDs

| LED | Status | Description | Response |
|--------------------------|------------|---|--|
| DC Power ON/OFF | Off | DC power OFF | None required (normal) |
| | ON (Green) | DC power ON | None required (normal) |
| Power Alarm ¹ | Off | Not active | None required (normal) |
| | ON (Amber) | Failure has occurred in one or more power supplies (see the "Power Supply Status Indicators" table DC Power Status "Amber" that follows.) | |
| Fan Alarm | Off | All fans operating normally | None required (normal) |
| | ON (Amber) | Fan failure | Replace fan in chassis or replace power supply |
| Array Alarm | Off | Always OFF unless RAID is installed | None required (normal) |
| | ON (Amber) | RAID Array failure | Replace disk drive with amber light lite |

¹Valid only when a second power supply is installed.

 **Note:** The Power Supply Status Indicator LEDs are present only when a second power supply is installed.

Power Supply Status Indicator LEDs (Rear Panel)

| LED | Status | Description | Response |
|---------------------|------------|--|---|
| Power Supply Status | Off | AC Power not available | None required (normal) |
| | ON (Green) | AC Power supplied to power supply | None required (normal) |
| DC Power Status* | Off | No alarms | None required (normal) |
| | (Amber) | AC Power disconnected or power supply failed | Verify AC power is ON, reconnect AC power, or replace power supply, |

*Connects to the Power Alarm light.

 **Note:** The Disk Drive Status Indicator LEDs are active only when a RAID board is installed.

Front Disk Drive Status Indicator LEDs

| LED | Status | Description | Response |
|---------------------|---------------|--|------------------------|
| Disk Drive Activity | Off | Not accessing disk drive | None required (normal) |
| | ON (Green) | Accessing disk drive | None required (normal) |
| Disk Drive Status | Off | No alarms | None required (normal) |
| | ON (Amber) | (See the "Disk Drive Status Conditions" table that follows.) | |

Disk Drive Status Conditions

| Condition | LED |
|---------------------------|--|
| No Error | Off |
| Faulty or Rebuild Stopped | Steady ON |
| Rebuild | Slow Blink for approximately one second |
| Identify | Fast Blink for approximately three seconds |
| Predicted Fault | Four fast blinks, pause (repeats) |
| Hot Spare | Two fast blinks, pause (repeats) |

LAN Status Indicator LEDs (I/O Panel)

| LED | Status | When On | When Blinking | When Off |
|------------------|---------------|-----------------------------|--|----------------------------|
| LAN Link Status | Green | N/A | Linked to network, sending or receiving data | N/A |
| LAN Speed Status | Orange | 100 Mbps network connection | None | 10 Mbps network connection |

Making Connections

If your system normally operates without a video display or keyboard (for example, as a network server), you must install a video display and keyboard to configure the system. You may remove them after running the System Setup Utility (SSU). For information on running the SSU, refer to Appendix B of this User's Guide.

Refer to the previous figure (Rear Features and Controls) and connect your keyboard, monitor, and mouse. Connect any external peripheral devices such as a printer or modem by following the instructions included with these devices.



CAUTION

Damage to the system may result if the keyboard/mouse cable is inserted or removed when power is applied to the system.

Inserting a telephone line connector into a LAN board RJ-45 port may result in personal injury and equipment damage.

Setting the Line Voltage

The system contains an ATX300 watt power supply that is switch-selectable for 115 or 230 VAC at an operating frequency of 50/60Hz. The power supply voltage selection switch is factory set to 115Vac for systems shipped to North America; it is set to 230Vac for systems shipped in Europe. Line source voltages between 200 and 240 VAC are acceptable when the power supply input voltage is set to 230 VAC.



CAUTION

Before you plug the system power cord into an AC outlet, ensure the input line voltage setting for the power supply is correct.

To use the system with line source voltages between 200 and 240 VAC, the line voltage selector switch on the power supply must be set to 230. If you set the switch to the 115 VAC position, the power supply will be damaged when you plug in your system.

When two power supplies are installed in the system both power supplies must have their line voltage selector switch set to the same voltage.

If you need to change the line voltage setting, perform the following steps.

 **Note:** If you are setting up your system for the first time, the power cord will not be connected to the rear panel of your system.

1. Unplug the AC power cord from the back of the chassis.
2. Insert the tip of a small screwdriver or ballpoint pen into the depression on the line voltage selector.
3. Slide the selector switch to the left for 115 VAC or to the right for 230 VAC (line source voltage range: 220 to 240 VAC).

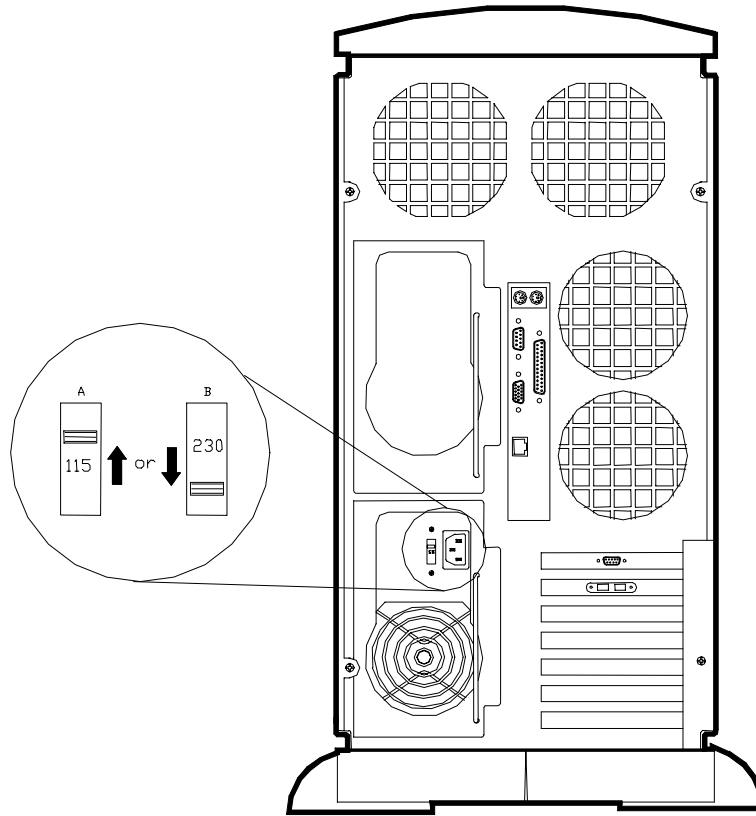

Setting the Line Voltage

- A. Voltage selector switch set to 115 VAC
- B. Voltage selector switch set to 230 VAC

Connecting the Power Cord(s)

Plug the female end of the AC power cord into the input receptacle on the rear of the power supply cage. Plug the male end of the power cord into NEMA 5-15R outlet for 100-120 VAC or NEMA 6-15R outlet for 200-240 VAC.

If the power cord(s) supplied with the system are not compatible with the AC wall outlet in your region, obtain a suitable power cord that meets the following criteria.

- The power cord must be rated for the available AC voltage and have a current rating that is at least 125% of the current rating of the system.
- The power cord connector that plugs into the wall outlet must be terminated in a grounding-type male plug designed for use in your region. It must have certification marks showing certification by an agency acceptable in your region.
- The power cord connector that plugs into the system must be an IEC-type CEE-22 female connector.
- The power cord must be less than 1.8 meters (6.0 feet) long.

WARNING

Your system shipped with a power cord for each power supply. Do not attempt to modify or use the supplied AC power cord if it is not the exact type required.

CAUTION

When two power supplies are installed in the system the power plug from each of the power supplies must be plugged into the same common ground power outlets.

Powering On Your System

Power on your system as follows.

1. Make sure all external devices, such as a video display, keyboard, and mouse (optional) have been connected, and the power cords are connected.
2. Power on the video display and any other external devices.
3. Press the push-button power on/off switch on the front panel. Verify that the system power-on LED is lit. If it is not lit, ensure the ac power cords are connected to a functional ac power source.

After a few seconds your system begins the internal Power-On Self Tests (POST). POST automatically checks the system board, CPU module, memory, keyboard, and most installed peripheral devices.



CAUTION

Always allow POST to complete before powering down your system.



CAUTION

The server management logic on your system board monitors and logs system voltage changes. When powering down your system you may experience a 1–5 second delay from the time you press the push-button power on/off switch on the front panel and your system powering down. This is normal system operation and is required by the server management logic.

If you have problems powering on your system, refer to *Problem Solving* in Chapter 5 of this User's Guide.

After you have successfully powered on your system, insert the EXPRESSBUILDER CD-ROM into the CD-ROM device, reboot the system and follow the screen prompts to run EXPRESSBUILDER.

3

Configuring Your System

- Configuring Your System
- BIOS Setup Utility
- Symbios Configuration Utility
- Optional RAID Controllers
- Configuring System Board Jumpers

Configuring Your System

Configuration and setup utilities are used to change your system configuration. You can configure your system, as well as option boards you may add to your system, using the BIOS Setup Utility. Several unique system parameters are configured using the BIOS Setup, which is stored in the system FLASH memory.

You can also configure your system, including reserving resources required by the option boards, using the System Setup Utility (SSU). Also, the SSU is used to read stored system event information. Information on the SSU may be found in Appendix B of this User's Guide.

The Symbios Configuration Utility detects the SCSI host adapters on the system board. Use this utility if you need to configure the two SCSI controllers in your system or to perform a SCSI disk format or verify disk operation on the SCSI disk drives. The Symbios Configuration Utility is also used to configure any SCSI removable media devices installed in your system.

If your system has been factory configured, the SSU, BIOS Setup, or Symbios Configuration Utility do not need to be run unless you want to change the password or security features, add certain types of option boards or devices, or upgrade your system board.

This chapter also provides information on several system configuration parameters that are set by jumpers on the system board. However, these parameters do not usually require change.

Use the EXPRESSBUILDER CD-ROM to create the device driver and SSU diskettes.

BIOS Setup Utility

The BIOS Setup Utility is used to change system configuration parameters. This utility has some unique parameters and many parameters that are also configurable with the SSU. The utility is resident in the system FLASH memory and does not require a diskette or an operating system present to run. However, parameters set with the BIOS Setup Utility that can also be set with the SSU, will be overwritten by the SSU the next time the SSU is run.

Using the BIOS Setup Utility

You access the BIOS Setup utility when you turn on or reboot your system. To run the BIOS Setup Utility, perform the following procedure:

1. Power-on or reboot the system. “Press <F2> to enter SETUP” displays.
2. Press **F2**. The BIOS Setup Utility starts and the Main Menu is displayed. The menu bar at the top of the Main Menu lists the following selections:

| Menu | Use |
|----------|--|
| Main | Use this menu for basic system configuration. |
| Advanced | Use this menu for setting the Advanced Features available on your system. |
| Security | Use this menu to set User and Supervisor Passwords and the Backup and Virus-Check reminders. |
| Server | Use this menu for configuring Server Management features. |
| Boot | Use this menu to configure Boot Device priority. |
| Exit | Exits the current menu. |

Use the arrow keys to select a menu or an item on a displayed menu. Press the value keys (listed in the table below) to cycle through the allowable values for the selected field. Use the Exit menu’s “Save Values” selection to save the current values on all the menus.

To display a submenu, position the cursor on a selection that has a submenu and press **ENTER**. An arrow precedes selections with submenus.

Refer to the following table for information on the keys that you use with BIOS Setup. These keys are also listed at the bottom of the Setup menu.

| Key | Function in Setup Menu |
|--------------------------|---|
| F1 or Alt-H | Get Help about an item. |
| ESC | Exit the current menu and return to the previous menu. |
| Left or right arrow keys | Move between menus. |
| Up or down arrow keys | Move cursor up and down. The cursor moves only to the settings that you can change. |
| HOME or END | Move cursor to top or bottom of window. |
| PAGE UP or PAGE DOWN | Move cursor to next or previous page. |
| F5 or - | Select the previous value for the field. |
| F6 or + or SPACE | Select the next value for the field. |
| F9 | Load default configuration values for this menu. |
| F10 | Save configuration values and exit. |
| ENTER | Execute command or Select submenu. |

BIOS Setup Configuration Settings

The BIOS Setup Configurations tables show the default settings for the BIOS Setup Utility and provides a place for you to record any changes you make to these settings. Recommended values are bold in the following tables.

Main Menu

| Feature | Choices | Description | Your Setting |
|----------------------|--|---|--------------|
| System Time | HH:MM:SS | Sets the system time. | |
| System Date | MM/DD/YYYY | Sets the system date. | |
| Legacy Diskette A: | Disabled 360KB 1.2 MB 720KB 1.44/1.25 MB 2.88 MB | Selects the diskette type. The 1.25 MB diskette requires a 3-mode diskette drive. | |
| Legacy Diskette B: | Disabled 360KB 1.2 MB 720KB 1.44/1.25 MB 2.88 MB | Selects the diskette type. | |
| Primary IDE Master | Press ENTER | Refer to "Primary IDE Master and Slave Submenu." | |
| Primary IDE Slave | Press ENTER | Refer to "Primary IDE Master and Slave Submenu." | |
| Secondary IDE Master | Press ENTER | Refer to "Secondary IDE Master and Slave Submenu." | |
| Secondary IDE Slave | Press ENTER | Refer to "Secondary IDE Master and Slave Submenu." | |
| Keyboard Features | Press ENTER | Refer to "Keyboard Submenu." | |
| Processor Settings | Press ENTER | Refer to "Processor Settings Submenu." | |
| Language | English (US) French, Spanish, German, Italian | Selects which language BIOS displays. | |

Primary IDE Master and Slave Submenu

| Feature | Choices | Description | Your Setting |
|-----------------------|--|--|--------------|
| Type | Auto None CD-ROM IDE Removable ATAPI Removable User | Auto allows the system to attempt auto-detection of the drive type. None informs the system to ignore this drive. CD ROM allows the manual entry of fields described below. Determines that a removable IDE drive is installed. IDE allows the manual entry of fields described below. Determines that a removable ATAPI drive is installed. ATAPI allows the manual entry of fields described below. User allows the manual entry of all fields described below. | |
| Multi-Sector Transfer | Disabled 2, 4, 8, or 16 sectors | Determines the number of sectors per block for multi-sector transfers. This field is informational only for Type Auto. | |
| LBA Mode Control | Disabled Enabled | Enabling LBA causes logical block addressing to be used in place of cylinders, heads, and sectors. This field is informational only for Type Auto. | |
| 32 Bit I/O | Disabled Enabled | Enabling allows 32 bit IDE data transfers. | |
| Transfer Mode | Standard Fast PIO 1 Fast PIO 2 Fast PIO 3 Fast PIO 4 FPIO 3/DMA 1 FPIO 4/DMA 2 | Selects the method for moving data to and from the drive. This field is informational only for Type Auto. | |
| Ultra DMA Mode | Disabled Mode 0 Mode 1 Mode 2 | Selects the Ultra DMA Mode for moving data to and from the drive. Autotype the drive to select the optimum transfer mode. | |

Secondary IDE Master and Slave Submenu

| Feature | Choices | Description | Your Setting |
|-----------------------|--|---|--------------|
| Type | Auto None CD-ROM IDE Removable ATAPI User | Auto allows the system to attempt auto-detection of the drive type. None informs the system to ignore this drive. CD ROM allows the manual entry of fields described below. Determines that a removable IDE drive is installed. IDE allows the manual entry of fields described below. Determines that a removable ATAPI drive is installed. ATAPI allows the manual entry of fields described below. User allows the manual entry of all fields described below. | |
| Multi-Sector Transfer | Disabled 2, 4, 8, or 16 sectors | Determines the number of sectors per block for multi-sector transfers. This field is informational only for Type Auto. | |
| LBA Mode Control | Disabled Enabled | Enabling LBA causes logical block addressing to be used in place of cylinders, heads, and sectors. This field is informational only for Type Auto. | |
| 32 Bit I/O | Disabled Enabled | Enabling allows 32 bit IDE data transfers. | |
| Transfer Mode | Standard Fast PIO 1 Fast PIO 2 Fast PIO 3 Fast PIO 4 FPIO 3/DMA 1 FPIO 4/DMA 2 | Selects the method for moving data to and from the drive. This field is informational only for Type Auto. | |
| Ultra DMA Mode | Disabled Mode 0 Mode 1 Mode 2 | Selects the Ultra DMA Mode for moving data to and from the drive. Autotype the drive to select the optimum transfer mode. | |

Keyboard Submenu

| Feature | Choices | Description | Your Setting |
|----------------------------|---|--------------------------------------|--------------|
| NumLock | On Off | Selects power-on state for Num Lock. | |
| Key Click | Disabled Enabled | Enables or disables key click. | |
| Keyboard auto-repeat rate | 13.3/sec 10/sec 6/sec 2/sec 30/sec 26.7/sec 21.8/sec 18.5/sec | Selects key repeat rate. | |
| Keyboard auto-repeat delay | 1/4 sec 1/2 sec 3/4 sec 1 sec | Selects delay before key repeat. | |

Processor Settings Submenu

| Feature | Choices | Description | Your Settings |
|-------------------------|----------------------------|--|---------------|
| CPU Speed Settings | Processor Speed List | Processor speed list is determined by the speed of the processor(s) installed. Select speed to match speed of installed processor(s). Caution: DO NOT select a speed above the speed of the installed processor(s). | |
| Processor Retest | No Yes | Select Yes if you want the BIOS to clear old processor status and retest all processors on next boot. | |
| Processor Serial Number | Disabled Enabled | Controls detection of processor serial number. Note: displays only when Pentium III is installed. | |
| Memory Cache | Enabled Disabled | Enables processor cache. | |

Advanced Menu

| Feature | Choices | Description | Your Setting |
|--------------------------------------|----------------------------|---|--------------|
| Installed OS | Other Win95 | Select the operating system installed in your system. | |
| Reset Configuration Data | No Yes | Select Yes if you want to clear the extended system configuration (ESCD) area during next boot. System automatically resets to No in next boot. | |
| PCI Configuration | Press ENTER | Refer to "PCI Configuration Submenu." | |
| Integrated Peripherals Configuration | Press ENTER | Refer to "Integrated Peripherals Configuration Submenu." | |
| Advanced Chipset Control | Press ENTER | Refer to Advanced Chipset Control Submenu." | |
| Use Multiprocessor Specification | 1.1 1.4 | Selects the version of multiprocessor specification to use. Some operating systems require version 1.1. | |
| Large Disk Access Mode | LBA CHS | Select LBA for IDE drives. This only effects IDE drives with partitions greater than 512 Mbytes. | |
| Delay on Option ROMs | Disabled Enabled | Forces a short delay at the end of each Option ROM scan. | |

PCI Configuration Submenus

This submenu should only be changed by qualified technical personnel.



CAUTION

Leave PCI Configuration Submenu at factory-default settings. This submenu should only be changed by a technically qualified person.

PCI Configuration Submenu

| Feature | Choices | Description | Your Setting |
|-----------------------------------|---|--|--------------|
| PCI Device, Embedded SCSI Devices | Press ENTER . | N/A | |
| Option ROM Scan | Enabled Disabled | Enables option ROM scan of the selected device. | |
| Enable Master | Enabled Disabled | Enabled selects the device as a PCI bus master. | |
| Latency Timer | Default 0020h 0040h 0060h 0080h 00A0h 00C0h 00E0h | Minimum guaranteed time, in units of PCI bus clocks, that a device may be master on a PCI bus. | |

PCI Device, Slot 1 - Slot 4 Submenus

This submenu should only be changed by qualified technical personnel.



CAUTION

Leave PCI Device Submenu at factory-default settings. This submenu should only be changed by a technically qualified person.

PCI Device Submenu

| Feature | Choices | Description | Your Setting |
|---------------|---|--|--------------|
| Enable Master | Enabled Disabled | Enables selected device as a PCI bus master. | |
| Latency Timer | Default 020h 040h 060h 080h 0A0h 0C0h 0E0h | Minimum guaranteed time, in units of PCI bus clocks, that a device may be master on a PCI bus. | |

Integrated Peripheral Configuration Submenu

| Feature | Choices | Description | Your Setting |
|---------------------------|---|--|--------------|
| COM 1: (Serial Port A) | Disabled Enabled Auto OS Controlled | Auto forces BIOS to configure the port. OS Controlled forces OS to configure the port. If this COM port is used for Console Redirection make sure I/O and IRQ are identical to the values in the server Setup Menu. | |
| Base I/O Address | 3F8 2F8 3E8 2E8 | Selects the base I/O address for COM port A. | |
| Interrupt | IRQ 4 IRQ 3 | Selects the IRQ for COM port A. | |
| COM 2: (Serial Port B) | Disabled Enabled Auto OS Controlled | Auto forces BIOS to configure the port. OS Controlled forces OS to configure the port. If this COM port is used for Console Redirection make sure I/O and IRQ are identical to the values in the server Setup Menu. | |
| Base I/O Address | 3F8 2F8 3E8 2E8 | Selects the base I/O address for COM port B. | |
| Interrupt | IRQ 4 IRQ 3 | Selects the IRQ for COM port B | |
| Parallel Port | Disabled Enabled Auto OS Controlled | Auto forces BIOS to configure the port. OS Controlled forces OS to configure the port. | |
| Mode | Output only Bi-directional EPP ECP | Selects parallel port mode. | |
| Base I/O Address | 378 278 | Selects the base I/O address for LPT port. | |
| Interrupt | IRQ 5 IRQ 7 | Selects the IRQ for LPT port. | |
| DMA channel | DMA 1 DMA 3 | Selects the DMA for LPT port. | |
| Floppy disk controller | Disabled Enabled | Enables onboard diskette controller. | |

Advanced Chipset Control

| Feature | Choices | Description | Your Setting |
|---------------------|----------------------------|---|--------------|
| 640 – 768K | Disabled Enabled | If enabled, ISA Master and DMA cycles are forwarded to PCI. | |
| Delayed Transaction | Disabled Enabled | Enable the delayed transaction mechanism when PIIX4 is target of a PCI transaction. | |
| Passive Release | Disabled Enabled | Enable the Passive Release mechanism on PHOLD# signal when PIIX4 is a PCI MASTER. | |

Security Menu

 **Note:** Enabling the Administrator Password field requires a password for entering Setup. The passwords are not case sensitive.

| Feature | Choices | Description | Your Setting |
|---------------------------|---------------------|--|--------------|
| User Password is | Clear Set | Status only; user cannot modify. Once set, this can be disabled by setting it to a null string, or by clearing password jumper on system board (see System Board Jumpers in Chapter 3). | |
| Administrator Password is | Clear Set | Status only; user cannot modify. | |
| Set User Password | Press ENTER | When the <Enter> key is pressed, the user is prompted for a password; press ESC key to abort. Once set, this can be disabled by setting it to a null string, or by clearing password jumper on system board (refer to System Board Jumpers in this chapter). | |

Security menu (Continued)

| Feature | Choices | Description | Your Setting |
|----------------------------------|--|--|--------------|
| Set Administrator Password | Press ENTER | When the <Enter> key is pressed, the user is prompted for a password; press ESC key to abort. Once set, this can be disabled by setting it to a null string, or by clearing password jumper on system board (refer to System Board Jumpers in this chapter). | |
| Password on Boot | Disabled Enabled | Requires password entry before boot. System will remain in secure mode until password is entered. Password on Boot takes precedence over Secure Mode Boot. | |
| Diskette Access | Administrator User | Controls access to diskette drives. | |
| Fixed Disk Boot Sector | Normal Write Protect | Write-protects boot sector on hard disk to protect against viruses. | |
| Secure Mode Timer | Disabled 1 min 2 min 5 min 10 min 20 min 1 hr 2 hr | Period of key/PS/2 mouse inactivity specified for secure mode to activate. A password is required for secure mode to function. Cannot be enabled unless at least one password is enabled. | |
| Secure Mode Hot Key (Ctrl-Alt-) | [] [A, B, ..., Z] | Key assigned to invoke the Quicklock feature. Cannot be enabled unless at least one password is enabled. | |
| Secure Mode Boot | Disabled Enabled | System will boot in secure mode. The user must enter a password to unlock the system. Cannot be enabled unless at least one password is enabled. | |

Security menu (Continued)

| Feature | Choices | Description | Your Setting |
|----------------------|----------------------------|---|--------------|
| Video Blanking | Disabled Enabled | Blank video when secure mode is activated. The user must enter a password to unlock the system. Cannot be enabled unless at least one password is enabled. | |
| Floppy Write Protect | Disabled Enabled | When secure mode is activated, the diskette drive is write protected. The user must enter a password to disable. Cannot be enabled unless at least one password is enabled. | |

Server Menu

| Feature | Choices | Description | Your Setting |
|-----------------------------|----------------------------|--|--------------|
| System Management | Press ENTER | Refer to "System Management Submenu." | |
| Console Redirection | Press ENTER | Refer to "Console Redirection Submenu." | |
| PCI IRQs to IO-APIC mapping | Disabled Enabled | If enabled, BIOS will describe direct PCI interrupt connections to IO APIC in multiprocessor table. Do not enable if OS does not support this feature. | |
| Processor Retest | No Yes | Select Yes to have BIOS clear all processor status and retest the processor(s) on bootup. | |
| SERR# Reporting | Disabled Enabled | If enabled, system will detect and report SERR on PCI buses. | |

System Management Submenu

| Feature | Choices | Description | Your Setting |
|-------------------------------|--|--|--------------|
| System Event Logging | Disabled Enabled | When enabled, BIOS and BMC will log system events. | |
| Clear Event Log | No Yes | Yes clears the system Event log. | |
| Sever Management Info | Press ENTER | Refer to "System Management Info Submenu." | |
| EMP Password Switch | Disabled Enabled | This field enables or disables EMP Password. | |
| EMP ESC Sequence | Refer to Appendix C. | | |
| EMP Hangup Line String | Refer to your modem documentation. | | |
| Modem Init String | Refer to your modem documentation. | | |
| High Modem Init String | Refer to your modem documentation. | | |
| EMP Access Mode | Disabled Always Active Pre-Boot Only Enabled | | |
| EMP Restricted Mode Access | Disabled Enabled | | |
| EMP Direct Connect/Modem Mode | Direct Connect Modem Mode | | |

Server Management Information Submenu

The user can modify no items on this menu. If items require changes, consult your system administrator.

| Feature | Choices | Description | Your Setting |
|-----------------------|---------|------------------------|--------------|
| Board Part Number | N/A | Information field only | |
| Board Serial Number | N/A | Information field only | |
| System Part Number | N/A | Information field only | |
| System Serial Number | N/A | Information field only | |
| Chassis Part Number | N/A | Information field only | |
| Chassis Serial Number | N/A | Information field only | |
| BMC Revision | N/A | Information field only | |
| Primary HSBP Revision | N/A | Information field only | |

Console Redirection Submenu

| Feature | Choices | Description | Your Setting |
|------------------|--|---|--------------|
| COM Port Address | Disabled 3F8 2F8 3E8 | When enabled, console redirection uses the I/O port specified. Make sure these values are identical to those of serial port A and B in the Peripheral Configuration Setup Menu. | |
| IRQ # | None 3 4 | When console redirection is enabled, this displays the IRQ assigned per the address chosen in the COM Port Address field. | |
| Baud Rate | 9600 19.2k 38.4k 115.2k | Communications line dependent. | |
| Console Type | PC ANSI VT100 | Communications line dependent. | |
| Flow Control | No Flow Control CTS/RTS XON/XOFF CTS/RTS + CD | Communications line dependent. | |

Boot Menu

| Feature | Choices | Description | Your Setting |
|----------------------|----------------------|--|--------------|
| Boot Device Priority | Press ENTER . | Refer to "Boot Device Priority Submenu." | |
| Hard Drive | Press ENTER . | Refer to "hard Drive Submenu." | |
| Removable Devices | Press ENTER . | Refer to "Removable Devices Submenu." | |

Boot Device Priority Submenu

Use the up or down arrow keys to select a device, then press the <+> or <-> keys to move the device higher or lower in the boot priority list.

Boot Device Priority Submenu

| Boot Priority | Device | Description | Your Setting |
|---------------|------------------------|--|--------------|
| 1. | Removable Devices | Attempts to boot from a removable media device. | |
| 2. | ATAPI CD-ROM Drive | Attempts to boot from an ATAPI CD-ROM drive. | |
| 3. | Hard Drive | Attempts to boot from a hard drive device. | |
| 4. | LANDesk® Service Agent | Attempts to boot from diagnostic boot partition of the flash memory. | |

Hard Drive Submenu

For options on this menu, use the up or down arrow keys to select a device, then press the <+> or <-> keys to move the device higher or lower in the boot priority list.

Hard Drive Submenu

| Option | Description |
|---|---|
| 1. Hard Drive #1 (or actual drive string) | <p>IDE drives will have a suffix attached to the drive ID string:</p> <ul style="list-style-type: none">PM - hard drive on Primary Master ChannelPS - hard drive on Primary Slave ChannelSM - hard drive on Secondary Master ChannelSS - hard drive on Secondary Slave Channel <p>SCSI CD-ROMs will be displayed here because the onboard Symbios SCSI bios treats CD-ROMs as hard drives.</p> <p>SCSI removable drives will also appear here.</p> |
| 2. Other Bootable Device | <p>Covers all the boot devices that are not reported to the system BIOS through the BIOS boot specification mechanism. This includes all PCI cards that are not bios boot compliant (legacy) as well as ISA cards that are not PnP compliant. ISA legacy cards will boot first before non-bios boot compliant PCI cards (in scan order from lowest slot to highest).</p> |

Removable Devices

For options on this menu, use the up or down arrow keys to select a device, then press the <+> or <-> keys to move the device higher or lower in the boot priority list.

Removable Devices Submenu

| Option | Description |
|------------------------|--|
| 1. Legacy Floppy Drive | Refers to the onboard 3.5" floppy drive. |

Exit Menu

You can make the following selections on the Exit Menu. Select an option using the up or down arrow keys, then press <Enter> to execute the option. Pressing <Esc> does not exit this menu. You must select one of the items from the menu or menu bar to exit.

Exit Menu

| Choices | Description |
|------------------------------|---|
| Exit Saving Changes | Exits after writing all modified Setup item values to CMOS. |
| Exit Discarding Changes | Exits leaving CMOS unmodified. |
| Load Setup Defaults | Loads default values for all Setup items. |
| Load Custom Defaults [ENTER] | Loads settings from custom defaults. |
| Save Custom Defaults [ENTER] | Saves present Setup values to custom defaults. |
| Discard Changes | Reads the previous value of all Setup items from CMOS. |
| Save Changes | Writes all Setup item values to CMOS. |

Symbios Configuration Utility

The Symbios Configuration Utility detects the two SCSI host adapters located on the system board. Use the utility to:

- Change adapter and SCSI device default values
- Check and/or change SCSI device settings that may conflict with those of other devices in the server.
- Perform low-level formatting or verify operations on SCSI disk drives.

Running the Symbios Configuration Utility

1. Power-on the system. The system boots up.
2. When this message appears on the video monitor:
Press Ctrl-C to start the Symbios Configuration Utility
Press **Ctrl+C** to run this utility.
3. The utility starts and the Main Menu displays.

Symbios Configuration Utility Main Menu

| Adapter | Port Number | IRQ Level | Status | | NVRAM Found |
|-----------|-------------|-----------|---------|-----------|-------------|
| | | | Current | Next Boot | |
| SYM53C875 | F800 | 11 | On | On* | Yes |
| SYM53C875 | F400 | 10 | On | On* | Yes |

Change Adapter Status – Press ENTER twice to change adapter Next Boot Status.

Adapter Boot Order – Press ENTER to select and change boot order of each SCSI adapter.

Additional Adapter Configuration – Not used.

Display Mode-Verbose – Press ENTER to change display mode.

Mono/Color – Press ENTER to change display from black/white to color.

Language – Not used.

Help/Quit

*Next Boot Status for this controller must be turned **OFF** if you install the optional Mylex AcceleRAID™ 150 (SecuRAID 110) or Mylex AcceleRAID™ 250 (SecuRAID 210) Controller board in your system. Refer to “Change Adapter Status” above.

The following keys are active for all SCSI Configuration screens:

| Key | Action |
|--------|---|
| Arrows | Up and down arrows move from one parameter to another within a screen. |
| ENTER | Displays options for a configurable parameter. Selects an option. |
| ESC | Moves back to previous screen or parameter or EXIT if at the Main menu. |

Changing the Adapter and Device Configurations

The SCSI Configuration Utility Main Menu lists the two onboard SCSI adapters and shows their current settings. The first adapter listed controls the operation of the hard disk drives in your system; the second adapter listed controls any SCSI removable media devices installed in your system.

1. Using the down arrow key, select the adapter you want to reconfigure. Press **ENTER**.
2. Select “Adapter Setup” and press **ENTER**. The Adapter Setup screen displays.

Adapter Setup Screen

| Description | Recommended Setting or Display Only | Your Configuration | |
|-------------------------|-------------------------------------|--------------------|----------------|
| | | SYM53C875 1 | SYM53C875 2 |
| SCAM Support | On | | |
| Parity | On | | |
| Host SCSI ID | 7 | | |
| Scan Order | Low to High | | |
| Removable media support | None | | |
| CHS Mapping | SCSI Plug and Play Mapping | | |

3. Highlight the function you want to change and press **ENTER**. You will be prompted to save changes when you exit the configuration utility.

To change device configuration parameters, perform the following steps:

1. At the SCSI Configuration Utility Main Menu, select the adapter which connects to the SCSI device you are reconfiguring. The first adapter listed controls the operation of the hard disk drives; the second adapter controls any SCSI removable media devices installed in your system. Press **ENTER**.
2. Select “Device Selections” and press **ENTER**. The Devices 0 to 7 screen displays.
3. Select the SCSI device you are reconfiguring and press **ENTER**. If you are configuring SCSI Hard Disk Drives, refer to the SYM53C875 Adapter 1 Table below; if you are configuring SCSI Removable Media Devices, refer to the SYM53C875 Adapter 2 Table below for recommended settings.

SYM53C875 Adapter 1 – SCSI Hard Disk Drives

| Description | Recommended Setting or Display Only | Your Configuration | | | |
|-------------------------------|--|--------------------|------|------|------|
| | | Dev0 | Dev1 | Dev2 | Dev3 |
| Device Selections | Press ENTER for menu. Select device and press ENTER. | | | | |
| Sync Rate | 40 | | | | |
| Width (bits) | 16 | | | | |
| Disconnect | On | | | | |
| Read/Write I/O timeout (secs) | 10 | | | | |
| Scan for device at boot time | Yes | | | | |
| Scan for SCSI LUNS | No | | | | |
| Queue Tags | On | | | | |

SYM53C875 Adapter 2 – SCSI Removable Media Devices

| Description | Recommended Setting or Display Only | Your Configuration | | | |
|-------------------------------|---|--------------------|------|------|------|
| Device Selections | Press ENTER for menu. Select device and press ENTER. | Dev0 | Dev1 | Dev2 | Dev3 |
| Sync Rate | 10 | | | | |
| Width (bits) | 8 | | | | |
| Disconnect | On | | | | |
| Read/Write I/O timeout (secs) | 10 | | | | |
| Scan for device at boot time | Yes | | | | |
| Scan for SCSI LUNS | No | | | | |
| Queue Tags | On | | | | |

4. Highlight the function you want to change and press **ENTER**. You will be prompted to save changes when you exit the configuration utility.

 **Note:** If you wish to format a disk or verify disk media, select “Format” or “Verify” from the Device Setup menu.

Optional RAID Controllers

Factory Installed Controllers

The RAID options available for your system are the dual channel Mylex AcceleRAID™ 150 (SecuRAID 110) and Mylex AcceleRAID™ 250 (SecuRAID 210) Controller boards, which gives your system the added security of fault tolerance.

If you order a system with a RAID controller, the system is pre-configured at the factory. Refer to the “RAID Configurations” table below to determine how the RAID controller was configured at the factory. If you want to reconfigure disk arrays and logical drives, you must run the AcceleRAID™ 150 or AcceleRAID™ 250 BIOS Configuration Utility; if you want to change the RAID level, you must run the Mylex Disk Array Controller Utilities (DACCF) software. Refer to the AcceleRAID™ 150 or AcceleRAID™ 250 documentation included with your system for information on running the AcceleRAID™ 150 or AcceleRAID™ 250 BIOS Configuration Utility and the DACCF utility.



CAUTION

Some server systems have network operating systems preloaded at the factory. If a network operating system is preloaded on your server system, then use of the DACCF utility is not required. However, if you do use the DACCF utility you may need to reload the network operating system. Make sure that you have all the pertinent software to perform the reload.

RAID Configurations

| Number of Hard Drives | RAID Level Configured | Hard Drives in Array | Description |
|-----------------------|-----------------------|--------------------------|---|
| 1 | JBOD | 1 | JBOD (RAID 0) JBOD is an acronym for Just a Bunch Of Disks. Each drive can operate independently as with a common host bus adapter; or multiple drives may be spanned and seen as a single very large drive. No redundancy is provided. |
| 2 | 1 | 2 | Mirroring (RAID 1) Drives are paired and mirrored. All data is 100% duplicated on an equivalent drive (fully redundant). |
| 3 | 5 | 3 | Striping with Parity (RAID 5) Data is striped across several physical drives. Parity protection is used for data redundancy. |
| 4 | 5 | 3 plus 1 hot spare drive | Striping with Parity (RAID 5) Data is striped across three physical drives. Parity protection is used for data redundancy. This drive is used as the “Hot Spare.” |
| 5 or more | — | — | The first four disks are as stated above. The remaining disks are not part of the array, but are ready to be configured. |

Add-on Controller

If you are adding a RAID controller to an existing system, the AcceleRAID™ 150 or AcceleRAID™ 250 BIOS Configuration Utility allows you to configure disk arrays and logical drives in your system. Since the utility resides in the AcceleRAID™ 150 or AcceleRAID™ 250 BIOS on the RAID controller, its operation is independent of the operating system in your server. Refer to Chapter 4 in this User's Guide for information on installing an add-in option board. Refer to Chapter 4 of the AcceleRAID™ 150 or AcceleRAID™ 250 Installation Guide for information on running the AcceleRAID™ 150 or AcceleRAID™ 250 BIOS Configuration Utility.

 **Note:** Next Boot Status for the first Symbios SYM53C875 controller must be turned **OFF** if you install the optional Mylex AcceleRAID™ 150 (SecuRAID 110) or Mylex AcceleRAID™ 250 (SecuRAID 210) Controller board in your system. Refer to “Symbios Configuration Utility” found earlier in this chapter.

DACCF Configuration Utility

The DACCF utility is included with the RAID controller. The AcceleRAID™ 150 and the AcceleRAID™ 250 support various versions of RAID technology (referred to as RAID levels). To use any RAID level, you must configure the RAID controller using the DACCF Configuration Utility prior to installing your Network Operating System. For an explanation of this utility, refer to the *Disk Array Controller Configuration Utilities Manual* that was shipped with the controller. Chapter 2 (*Preparing the Array*) covers array hardware preparation, configuration, and initialization. After completing the steps in Chapter 2, you can install your Network Operating System.

Configuring System Board Jumpers

Before You Begin

Only a qualified technical person should perform the procedures in this section.

CAUTION

Electrostatic discharge (ESD) can damage the system board. Modify the system board only at an ESD workstation. Otherwise, wear an antistatic wrist strap attached to chassis ground.

The system board jumpers enable you to set specific operating parameters for your system. A jumper is a small plastic-encased conductor (shorting plug) that slips over two jumper pins.

The “System board Jumpers” illustration shows the location of the system board jumpers. The “System Board Jumper Configurations” table lists the system board jumpers and their factory default settings.

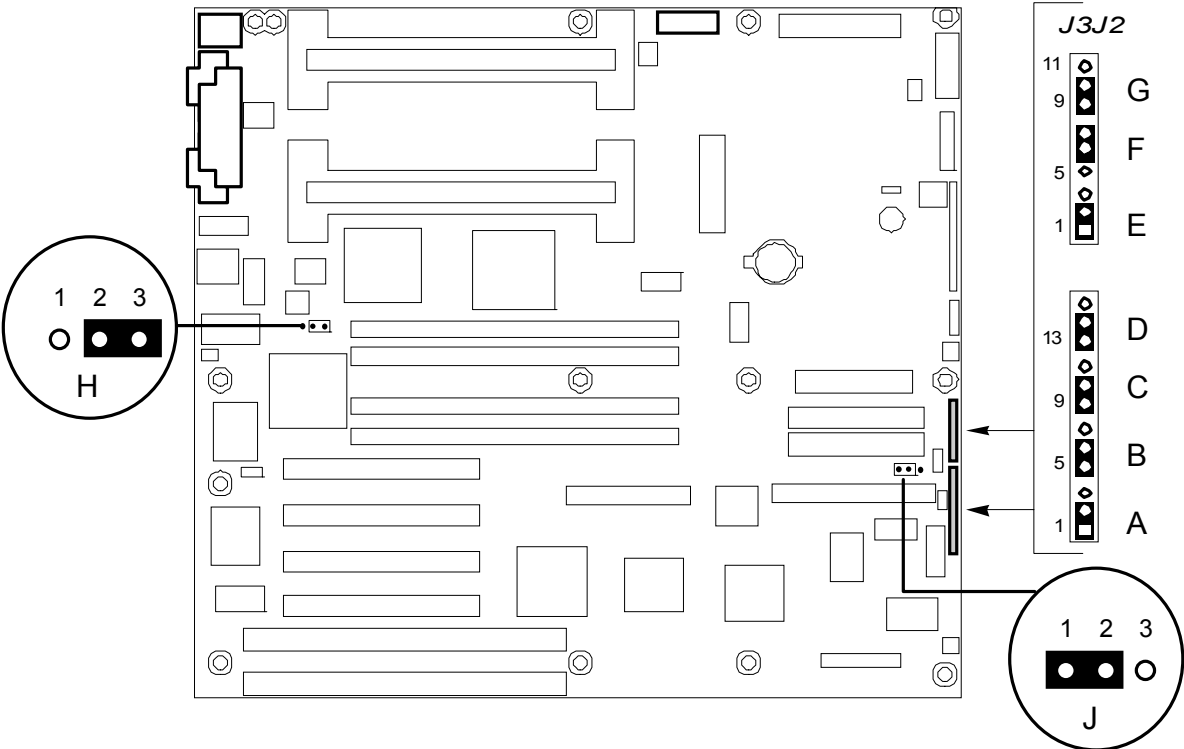

System Board Jumpers

System Board Jumper Summary

| Jumper | Function | Pins (default in bold) | What it does at system reset |
|--------|-----------------------------|------------------------|--|
| A | CMOS clear | 1-2, Protect | Preserves the contents of NVRAM. |
| | | 2-3, Erase | Replaces the contents of NVRAM with the manufacturing default settings. |
| B | Password clear | 5-6, Protect | Maintains the current system password. |
| | | 6-7, Erase | Clears the password. |
| C | Recovery Boot | 9-10, Normal | System attempts to boot using the BIOS stored in flash memory. |
| | | 10-11, Recovery | BIOS attempts a recovery boot, loading BIOS code from a floppy diskette into the flash device. This is typically used when the BIOS code has been corrupted. |
| D | Boot Block Write Protect | 13-14, Protect | BIOS boot block is write-protected. |
| | | 14-15 Erase/Program | BIOS boot block is erasable and programmable. |
| E | FRB Timer Enable | 1-2, Enable | FRB operation is enabled (system boots from processor 1 if processor 0 fails). |
| | | 2-3, Disable | FRB is disabled. |
| F | Chassis Intrusion Detection | 5-6, Enable | Switch installed on chassis indicates when cover has been removed. |
| | | 6-7, Disable | Chassis intrusion switch is bypassed. |
| G | BMC Forced Update Mode | 9-10, 10-11 | System boots normally System tries to boot BMC firmware. |
| H | Reserved | 2-3 | Required. Do Not Change |
| J | Reserved | 1-2 | Required. Do Not Change |

Moving System Board Jumpers



Before doing the procedures in this section, make sure that your system is powered off and unplug the AC power cords from the back of the chassis. Failure to disconnect power before moving the jumpers can result in personal injury and equipment damage.

Observe static precautions. Use an antistatic wrist strap.

To configure the system board options:

- 1.** Power off the system and remove the left panel as described in Chapter 4 of this guide.
- 2.** Check to ensure the system power cord is removed from the back of the system.
- 3.** Locate the position of the jumpers on the system board you are changing. To change a jumper setting, use a pair of needle-nose pliers or your fingers to remove the jumper from its current location. Position the jumper over the two pins for the desired setting and press it onto the pins. Be careful not to bend the pins. Refer the System Board Summary table for system board jumper settings.
- 4.** Install the system cover and power up the system.

Resetting the CMOS NVRAM

Use the clear CMOS memory procedures, which includes the reset CMOS NVRAM process, under "Enable F2 Prompt by Changing a Jumper and Using SSU" in Chapter 5.

Clearing and Changing the Passwords

To clear and change the passwords:

1. Power off the system and remove the left panel as described in chapter 4 of this guide.
2. Move the Password Clear jumper from pins 5-6 to pins 6-7. Refer to "Configuring System Board Jumpers" to see the location of this jumper.
3. Power on the system and wait for POST to complete. This automatically clears the old password.
4. Power off the system.
5. Move the Password Clear jumper back to pins 5-6.
6. Replace the panel and power on the system.
7. To specify a new password run the BIOS Setup Utility as described earlier in this chapter.

Recovering the BIOS

Qualified technical personnel should only perform this procedure.



CAUTION

Leave Recovery Boot jumper at factory-default setting.
A technically qualified person should only move this jumper.

Boot Block Write Protect

The jumper at pins 13, 14, and 15 controls whether the BIOS boot block is protected from being erased and reprogrammed.



CAUTION

Leave boot block jumper at factory-default setting:
Programming the boot block incorrectly will prevent the system from booting. A technically qualified person should only do programming. The procedure requires a special "Boot Block Update Utility." Contact your dealer or sales representative for more information.

Fault Resilient Booting (FRB) Timer Enable Jumper

Fault resilient booting insures the system will not stop from a boot problem. Two sets of timers are implemented that will automatically reset the system if the system should halt for some reason.

- FRB 2 - 5 sec timer. If the primary processor does not come up in 5 seconds the system will automatically reset and switch to the secondary processor secondary (if installed otherwise it will try to boot again off of the primary.)
- FRB 3 - 7 minute timer. If the system does not make it up to the end of POST in 7 minutes, the system will automatically reset and try again. It is assumed that the processor failed regardless of what may have caused the system to hang. The primary processor is taken off line and the system will boot off the secondary (if installed otherwise it will try to boot again off of the primary.) Bad memory or a bad plug in card may cause a FRB 3 failure.

All failures are logged to the system event log.

The system will remember all FRB errors and display them at the end of POST until you select the Processor Retest option from the BIOS Setup utility.



CAUTION

For normal operation leave FRB Timer Enable jumper at factory-default setting.

To disable the FRB Timer Enable:

1. Power off the system and remove the left panel as described in Chapter 4 of this guide.
2. Move the FRB Timer Enable jumper from pins 1-2 to pins 2-3. Refer to “Configuring System Board Jumpers” to see the location of this jumper.
3. Replace the panel and power on the system.
4. Power on the system and wait for POST to complete.
5. Run the SSU to configure the system.

Chassis Intrusion Detection Jumper

The chassis contains an alarm switch that sends a notification signal to the server management software if a cover is removed. The jumper at pins 5, 6, and 7 controls whether this alarm feature is enabled or disabled.



CAUTION

For normal operation leave Chassis Intrusion Detection jumper at factory-default setting.

To disable the chassis intrusion switch:

1. Power off the system and remove the left panel as described in Chapter 4 of this guide.
2. Move the chassis intrusion detection jumper from pins 5-6 to pins 6-7 to disable the alarm switch.
3. Reinstall the side cover for your safety, and connect the power cord to the system.
4. Power on the system on, and wait for POST to complete.
5. Run the SSU to configure the system.

BMC Forced Update Mode



CAUTION

Leave BMC Forced Update Mode jumper at factory-default setting: Setting this jumper incorrectly will prevent the system from booting. A technically qualified person should only do programming. Contact your dealer or sales representative for more information.

4

Upgrading Your System

- General Information
- Static Precautions
- Preparing Your System for Upgrade
- Equipment Log
- Opening the Front Door
- Removing a Side Panel
- Installing a Side Panel
- Modifying the System Board
- Option Boards
- Installing a RAID Controller Board
- Hard Disk Drives
- Removable Media Devices

General Information

WARNING

The DC push-button on/off switch on the front panel does not turn off the system AC power. Also, +5vdc is present on the system board whenever the AC power cords are connected between the system and an AC outlet. Before doing the procedures in this manual, make sure that your system is powered off and unplug the AC power cords from the back of the chassis. Failure to disconnect power before opening your system can result in personal injury and equipment damage.

CAUTION

The server management logic on your system board monitors and logs system voltage changes. When powering down your system you may experience a 1–5 second delay from the time you press the push-button power on/off switch on the front panel and your system powering down. This is normal system operation and is required by the server management logic.

CAUTION

Operating your system with the side panels removed can damage your system components. For proper cooling and airflow, always replace the side panels before powering on your system.

 **Note:** Your system error log will be lost, if your system ac power source is off or disconnected.

Contact your sales representative or dealer for a list of approved optional peripheral devices.

Static Precautions

An electrostatic discharge (ESD) can damage disk drives, option boards, and other components. You can provide some ESD protection by wearing an antistatic wrist strap attached to chassis ground when handling system components.

Electronic devices can be easily damaged by static electricity. To prevent damage, keep them in their protective packaging when they are not installed in your system.

Preparing Your System for Upgrade

Depending on the upgrade, you will need one or more of the following tools:

- Phillips screwdriver (#1 bit and #2 bit)
- Flat-head screwdriver
- Small needle nose pliers
- Pen or pencil
- ESD workstation or antistatic wrist strap (recommended)

Equipment Log

Use the equipment log form located at the end of this manual to record the model and serial number of your system, all installed options, and any other pertinent information specific to your system. You will need this information when configuring your system.

Opening the Front Door

To open the front door (see "Front View with Front Door Opened" in Chapter 2.)

Removing a Side Panel

To install options in your system, you must remove the side panel on the left side of the system (as viewed from the front). The side panel on the right side of the system (as viewed from the front) only has to be removed when adding removable media devices or a second power supply. The right side panel removes in the same manner as the left side panel.

 **CAUTION**

For proper cooling and airflow, do not operate the system with the side panels removed. Always replace the panels before powering on the system.

 **WARNING**

If you are removing the side panel after the system is set up, you must first power off the system and all external devices and then **Unplug** the system power cord

To remove a side panel:

1. Power off the system and ensure it is disconnected from the ac wall outlet.
2. The side panel is secured to the chassis with two screws. Remove the screws securing the side panel. Save the screws for reattaching the side panel.
3. Slide the side panel toward the rear of the chassis. This unlocks the locking fingers behind the side panel.
4. Pull the side panel out and away from the chassis.

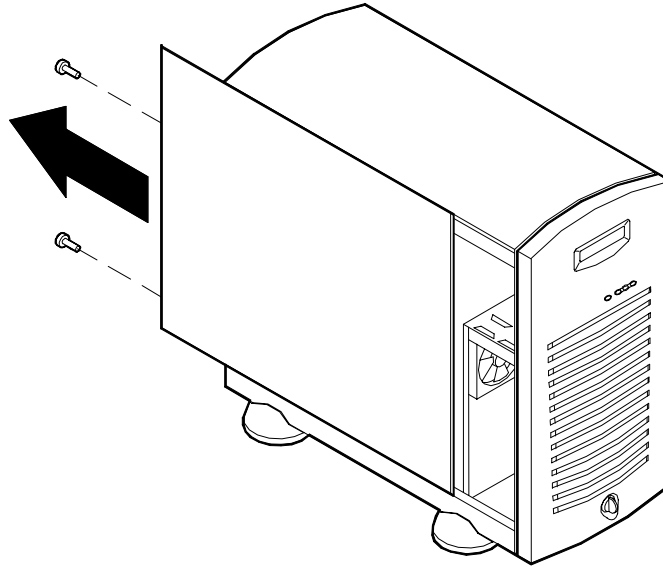

Removing a System Side Panel

Installing a Side Panel

1. Before replacing the side panel, make sure no tools or loose parts have been left inside the system chassis.
2. Make sure all option boards are firmly seated in their respective slots and that all interior cables are properly connected.
3. Insert the metal tabs on the top and bottom of the side panel into their slots on the chassis. Slide the side panel forward as far as it will go.
4. Replace the two side panels retaining screws.

 **Note:** If your system is already set up, plug the system back in, reconnect the peripherals, and power on the peripherals and system.

Modifying the System Board

The following sections provide procedures for upgrading and configuring the system board in your system. Topics covered include:

- Replacing the real-time clock battery
- Replacing a Pentium processor
- Installing or removing DIMMs.

CAUTION

Electrostatic discharge (ESD) can damage add-in boards and other components; place them on an antistatic surface. Modify the system board only at an ESD workstation. Otherwise, wear an antistatic wrist strap attached to chassis ground.

Replacing the Real-time Clock Battery

You may need to replace the real-time clock battery because of its life span. The battery (Vendor Part #CR2032) is a commodity part available through many vendors. Notice the plus (+) sign on the battery. This sign will assist you in correctly positioning the battery on the system board.

CAUTION

Danger of explosion if battery is incorrectly replaced. Replace only with same or equivalent type recommended by manufacturer. Dispose of lithium batteries as required by local ordinance or as normal waste if no local ordinance exists. Do not expose the component to excessive heat or fire. Keep all batteries away from children

CAUTION

Observe static precautions. Use an antistatic wrist strap.

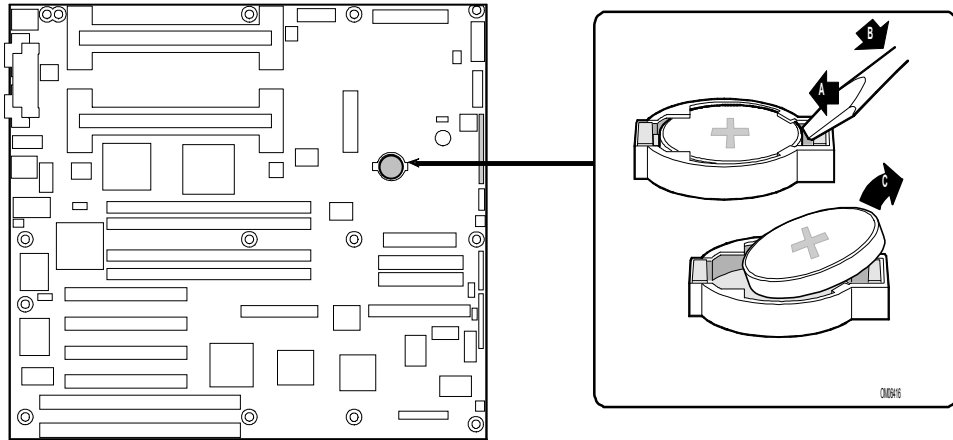

Replacing the Real-Time Clock Battery

- 1.** Power off the system and remove the left side panel as described earlier in this chapter.
- 2.** Insert the tip of a small flat-bladed screwdriver, or equivalent, under the plastic tab on the San-in plastic retainer (A in figure).
- 3.** Gently push down on the screwdriver to lift the battery (B).
- 4.** Remove the battery from its socket (C).
- 5.** Dispose of the battery according to local ordinance.
- 6.** Remove the new lithium battery from its package, and, being careful to observe the correct polarity, insert it in the battery socket.
- 7.** Reinstall the plastic retainer on the lithium battery socket.
- 8.** Replace the side panel, plug in the system power cord, and turn on the system.
- 9.** Run the BIOS Setup to restore the configuration settings to the real-time clock.

Replacing a Pentium Processor

This subsection provides the procedures for replacing (removing/installing) a Pentium II Processor or Pentium III Processor in your system. The procedures cover upgrading and configuring the Pentium II Processor in your system. The system board has sockets for two processors. Each Pentium II processor is packaged in a Single Edge Contact (S.E.C.) Cartridge and each Pentium III processor is packaged in a Single Edge Contact Cartridge Version2 (SECC2). The cartridge includes the processor core with an integrated 16 KB primary (L1) cache; the secondary (L2) cache; a thermal plate, and a back cover. The primary processor connector is shown at (A) in the illustration below. The secondary processor connector is shown at (B).

CAUTION

Electrostatic discharge (ESD) can damage components; place them on an antistatic surface. Modify the system board using an antistatic wrist strap attached to chassis ground.

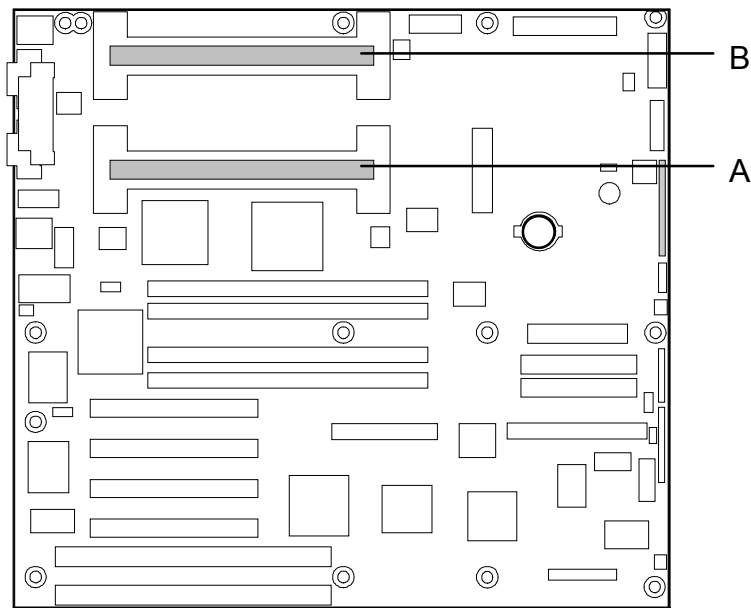

Replacing the Pentium II Processor

Removing the Pentium II Processor (S.E.C. Version)

WARNING

If the system has been running, any processor and heat sink already installed on the board will be hot. To avoid the possibility of a burn, let the components cool for 10 minutes before continuing with the procedures described here

1. Power off the system and remove the left side panel as described earlier in this chapter.

CAUTION

Observe static precautions. Use an antistatic wrist strap. Hold the processor only by its edges.

2. If your system has one processor and you are replacing it, leave the termination board intact in the empty secondary processor connector. Remove the processor you want to replace.
3. If your system has two processors and you are replacing one or both, remove the appropriate one(s).
4. Press the processor latches toward the center of the S.E.C. cartridge to free them from the retention module (see A in figure).
5. Lift the S.E.C. cartridge upward, out of the retention module.

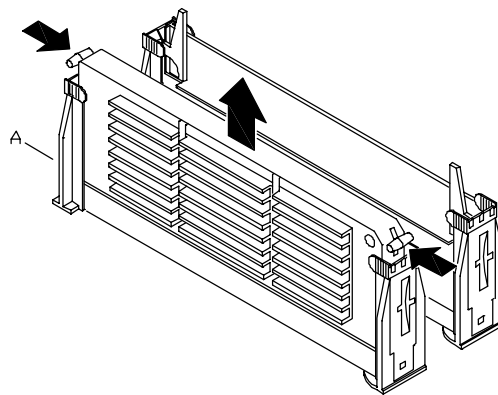

Removing a Processor

6. Put the processor in a piece of conductive foam and store in an antistatic package.
7. Proceed to the next section, “Installing the Pentium II Processor.”

Installing the Pentium II Processor (S.E.C. Version)

1. Power off the system and remove the left side panel as described earlier in this chapter.

CAUTION

Observe static precautions. Use an antistatic wrist strap.
Hold the processor only by its edges.

2. If your system has one processor and you are adding a second processor, then you must remove the termination board in the empty Slot 1 secondary connector. Press the tabs (see A in figure) on the top of the termination board bracket (see B in figure) toward each other to release them from the retention module. Lift the board bracket and the terminator board (C) up and out of the retention module, and store it appropriately.

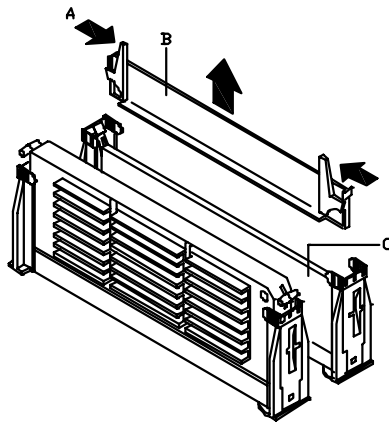

Removing a Termination Board

3. If your system has one processor and you are replacing it, leave the termination board intact in the empty Slot 1 secondary connector. Remove the processor you want to replace. See “Removing the Pentium II Processor.”
4. If your system has two processors and you are replacing one or both, remove the appropriate one(s). See “Removing the Pentium II Processor.”
5. Remove the new processor from its antistatic package and place it on a grounded, static-free surface or conductive foam pad.
6. Place the thermal pad on top of the processor so that the holes in the thermal pad line up with the holes in the processor.
7. Position the heat sink on top of the processor.
8. Install the two clips that secure the heat sink to the processor.

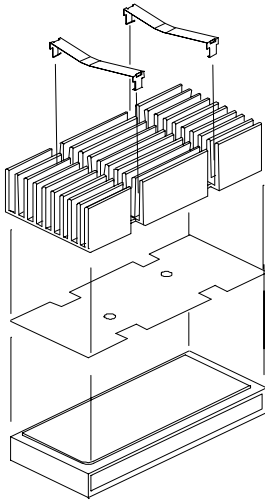

Assembling the Pentium II Processor

- 9.** Position the processor so that the heat sink faces the center of the system board. Slide the processor into the retention module. Ensure that the alignment notch in the S.E.C. cartridge fits over the plug in Slot 1. Push down firmly, with even pressure on both sides of the top, until the S.E.C. cartridge is seated.
- 10.** To lock in the processor, push the latches outward until they click into place in the retention module (see figure, below). The latches must be secured for proper electrical connection of the processor.

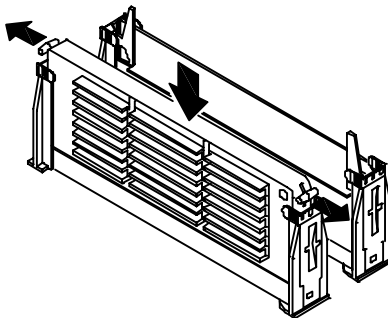

Locking in the Processor

- 11.** After you have installed a new processor, you must run the BIOS Setup Utility (F2) to configure its speed. Refer to Chapter 3, “Configuring Your System.”
- 12.** Replace the left side panel, plug in the system power cords, and power up the system.

! WARNING

If the system has been running, any processor and heat sink already installed on the board will be hot. To avoid the possibility of a burn, let the components cool for 10 minutes before continuing with the procedures described here

1. Power off the system and remove the left side panel as described earlier in this chapter.
-

! CAUTION

Observe static precautions. Use an antistatic wrist strap. Hold the processor only by its edges.

2. If your system has one processor and you are adding a second processor, then you must remove the termination board in the Slot 1 secondary connector and store it appropriately.
3. If your system has one processor and you are replacing it, leave the terminator board intact in the empty secondary processor connector. Remove the processor you want to replace.
4. If your system has two processors and you are replacing one or both, remove the appropriate one(s).
5. Pull the processor latches, Item A in Figure "Removing a Processor" below, out away from the edges of the SECC2 cartridge to free them from the Universal Retention Module (URM).
6. Lift the SECC2 cartridge upward, out of the URM and place it on a grounded, static-free surface or conductive foam pad.
7. Put the old processor in a piece of conductive foam and store in an antistatic package.

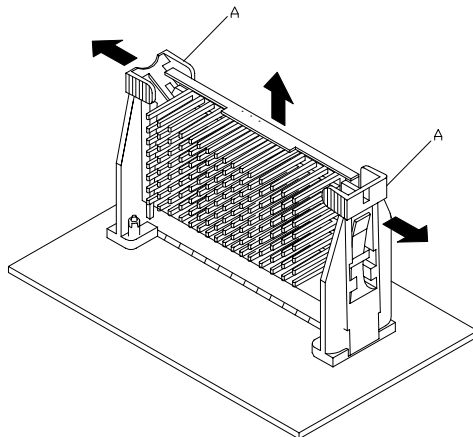

Removing a Processor

-
- 8.** Remove the new processor from its antistatic package and place it on a grounded, static-free surface or conductive foam pad.
 - 9.** Position the processor back into the URM. Ensure that the alignment notch on the bottom of the SECC2 cartridge fits into the connector key in Slot 1. Push down firmly, with even pressure on both sides of the top, until the cartridge is seated.
 - 10.** To lock in the processor, push the latches inward until they secure the SEC cartridge into place in the URM, Item A in Figure "Removing a Processor" above. The latches must be secured for proper electrical connection of the processor.
 - 11.** After you have installed a new processor, you must run the BIOS Setup Utility (F2) to configure its speed. Refer to Chapter 3, "Configuring Your System."
 - 12.** Replace the left side panel, plug in the system power cords, and power up the system.

Removing and Installing the Cooling Baffle

If your system has a cooling baffle, remove and install it as follows.

1. Remove the cooling baffle as follows.
 - Locate the two fans inside the chassis, at the rear of the chassis.
 - Remove four screws (two from each fan) from the fans, as shown in the following figure.
 - Remove the baffle.
2. Install the cooling baffle as follows.
 - Align the baffle mounting holes with the fan mounting holes.
 - Fasten the baffle in place with the four fan mounting screws.
 - Replace the left side panel, plug in the power cords, and power up the system.
 - Run the BIOS Setup utility (press **F2** at the startup screen) to configure your system's speed.

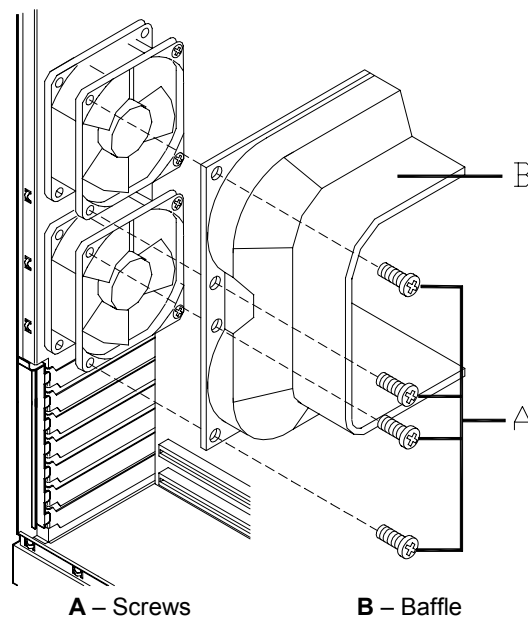

Removing/Installing the Cooling Baffle

 **Note:** The cooling baffle must be removed if you are adding or removing DIMMs or if you are adding or replacing processors.

DIMMs

The system board contains four DIMM sockets labeled 1 through 4. Each socket can hold a single 72-bit DIMM module with 32MB, 64MB, 128MB, or 256MB of memory. When all four sockets are populated, the system board supports a maximum of 1 GB of memory with 256MB DIMMs. A DIMM will always be installed in the bottom socket. When you install additional DIMMs, you must start with the first empty socket above DIMMs already installed. When you remove DIMMs, you must start with the first DIMM socket closest to the top edge of the system board.

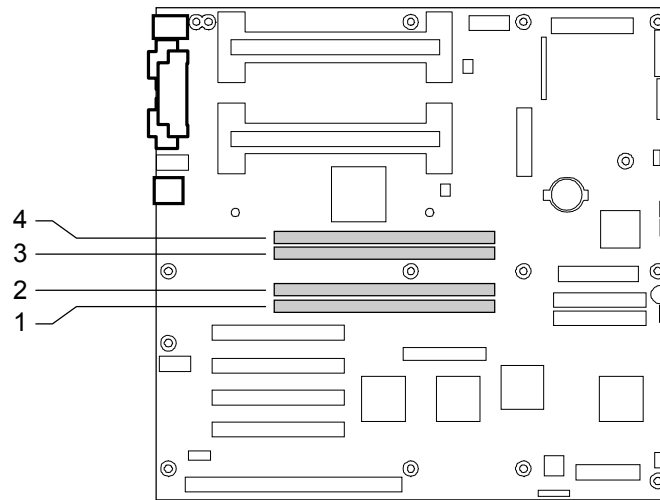

DIMM Locations

Memory DIMM Configurations

This table lists the distribution of DIMMs for specific memory configurations.

| System Capacity (MB) | Capacity per DIMM slot (MB) Any DIMM slot order | | | |
|----------------------|---|--------|--------|--------|
| | Slot 1 | Slot 2 | Slot 3 | Slot 4 |
| 32 | 32 | | | |
| 64 | 32 | 32 | | |
| 64 | 64 | | | |
| 96 | 32 | 32 | 32 | |
| 96 | 64 | 32 | | |
| 128 | 32 | 32 | 32 | 32 |
| 128 | 64 | 32 | 32 | |
| 128 | 64 | 64 | | |
| 128 | 128 | | | |
| 160 | 64 | 64 | 32 | |
| 160 | 64 | 32 | 32 | 32 |
| 160 | 64 | 64 | 32 | 32 |
| 192 | 64 | 64 | 32 | 32 |
| 192 | 64 | 64 | 64 | |
| 192 | 128 | 32 | 32 | |
| 192 | 128 | 64 | | |
| 224 | 64 | 64 | 64 | 32 |
| 224 | 128 | 32 | 32 | 32 |
| 224 | 128 | 64 | 32 | |
| 256 | 64 | 64 | 64 | 64 |
| 256 | 128 | 64 | 32 | 32 |
| 256 | 128 | 64 | 64 | |
| 256 | 128 | 128 | | |
| 256 | 256 | | | |
| 288 | 128 | 64 | 64 | 32 |
| 288 | 128 | 128 | 32 | |
| 320 | 128 | 64 | 64 | 64 |
| 320 | 128 | 128 | 32 | 32 |
| 320 | 128 | 128 | 64 | |
| 352 | 128 | 128 | 64 | 32 |
| 384 | 128 | 128 | 64 | 64 |
| 384 | 128 | 128 | 128 | |
| 384 | 256 | 128 | | |
| 416 | 128 | 128 | 128 | 32 |
| 448 | 128 | 128 | 128 | 64 |
| 512 | 128 | 128 | 128 | 128 |
| 512 | 256 | 256 | | |
| 640 | 256 | 256 | 128 | |
| 768 | 256 | 256 | 128 | 128 |
| 768 | 256 | 256 | 256 | |
| 896 | 256 | 256 | 256 | 128 |
| 1024 | 256 | 256 | 256 | 256 |

Installing DIMMs

1. Power off the system and remove the left side panel as described earlier in this chapter.



CAUTION

Observe static precautions. Use an antistatic wrist strap.
Hold DIMMs only by their edges.

2. Holding the DIMM module only by the edges, remove it from its antistatic package.
3. Position the DIMM so that the two notches in the bottom edge of the DIMM align with the keyed socket.

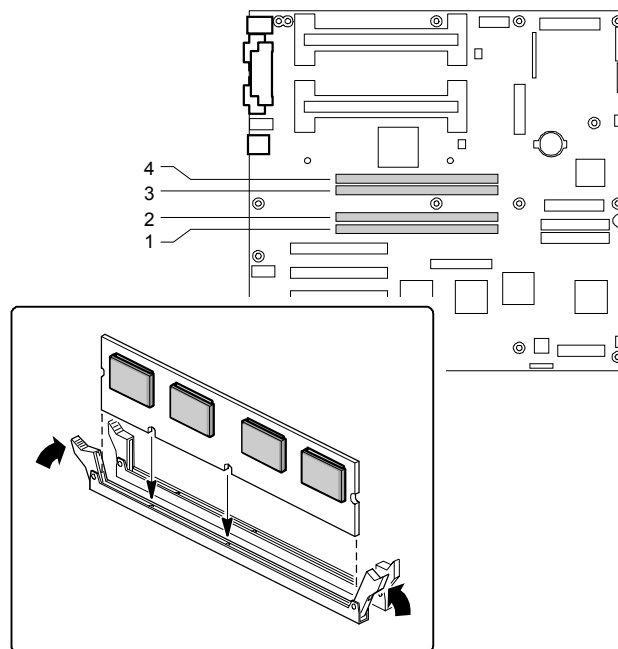

Inserting Memory DIMMs

4. Insert the bottom edge of the DIMM into the socket, and press down firmly on the DIMM until it seats correctly.
5. Gently push the plastic ejector levers on the socket ends to the upright position.
6. Repeat the steps to install each DIMM.
7. Replace the left side panel, plug in the system power cord, and turn on the system.

Removing DIMMs



Use extreme care when removing a DIMM. Too much pressure can damage the socket slot. Apply only enough pressure on the plastic ejector levers to release the DIMM

1. Power off the system and remove the left side panel as described earlier in this chapter.
2. Gently push the plastic ejector levers out and down to eject a DIMM from its socket.
3. Hold the DIMM only by its edges, being careful not to touch its components or gold edge connectors. Carefully lift it away from the socket, and store it in an antistatic package.
4. Repeat the above steps to remove the remaining DIMMs.
5. Replace the side panel, plug in the system power cord, and turn on the system.

Option Boards

This section describes how to install and remove ISA and PCI option boards. The system board has two ISA bus expansion slots and four PCI bus expansion slots. One of the ISA connectors shares a chassis expansion slot with a PCI connector.

The high-performance PCI local bus allows the adoption of newer networking technology, such as 100 Mb/second Ethernet NICs, with a minimum of effort and without concern for I/O bottlenecks. The PCI local bus offers up to 133 Mb/second bandwidth.

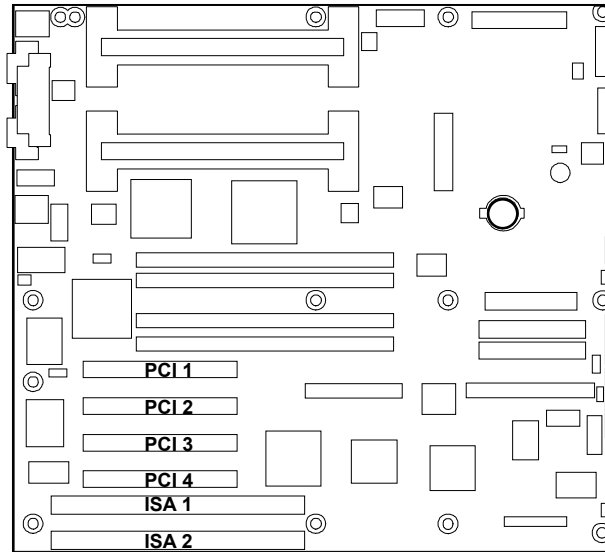

PCI and ISA Slot Locations

Installation Considerations

Newer adapters, designed for Plug-and-Play systems, are automatically configured by the system without any user intervention. Older ISA adapters must be manually configured as detailed below. Once the manual configuration is complete, the Plug-and-Play adapters are configured around the manually configured adapters without causing any resource conflicts.

ISA adapters can be Plug-and-Play. ISA adapters that are not Plug-and-Play must be manually configured following the instructions supplied with the board. The configuration is defined to the system by creating the ISA configuration file when running the SSU. If you are adding a non-Plug and Play ISA option board, run the SSU before installing the board. For details on running the SSU, refer to Appendix B.

Installing an Option Board

1. Power off the system and remove the left side panel as described earlier in this chapter.
2. Remove and save the expansion slot retainer bar by pressing down on its top snap fastener and pulling the bar out.

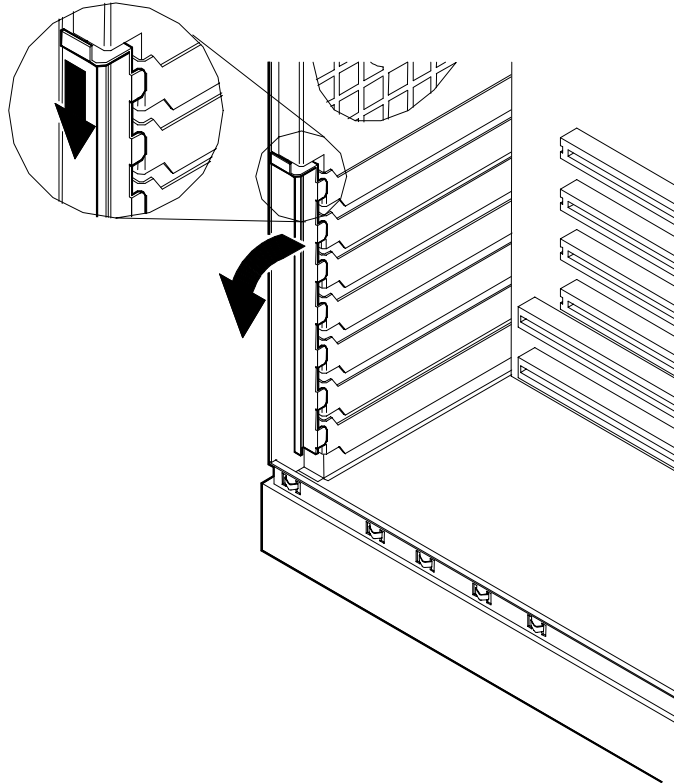

Removing the Expansion Slot Retainer Bar

-
3. Remove and save the expansion slot cover by sliding it straight back and out of the slot.

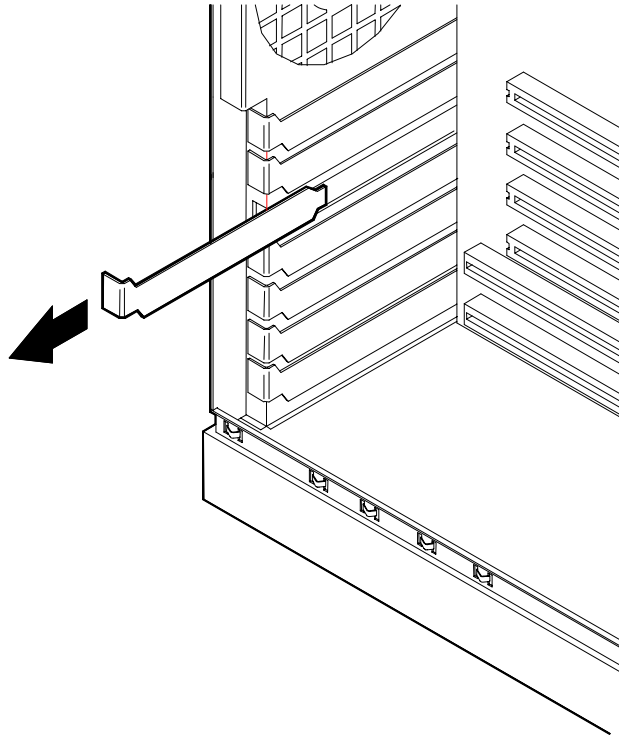

Removing the Expansion Slot Cover



CAUTION

Observe static precautions. Use an antistatic wrist strap.

4. Remove the option board from its protective wrapper, holding the board only by the edges. Do not touch the board components or the gold connectors.
5. Record the option board serial number in the equipment log.
6. Set any board jumpers or switches as described in the documentation that comes with the option board.
7. Refer to the documentation accompanying the option board for information on whether the board is a PCI or ISA board. Refer to “Option Board Hardware Configurations” table to determine the recommended option board slot assignment and configuration parameters.

 **Note:** If you are adding a non-Plug and Play Legacy ISA option board, run the SSU before installing the board. For details on the SSU, refer to Appendix B.

-
8. Holding the board by its top edge or upper corners, firmly press the board into an expansion slot on the system board. The tapered foot of the option board retaining bracket must fit into the mating slot in the expansion slot.

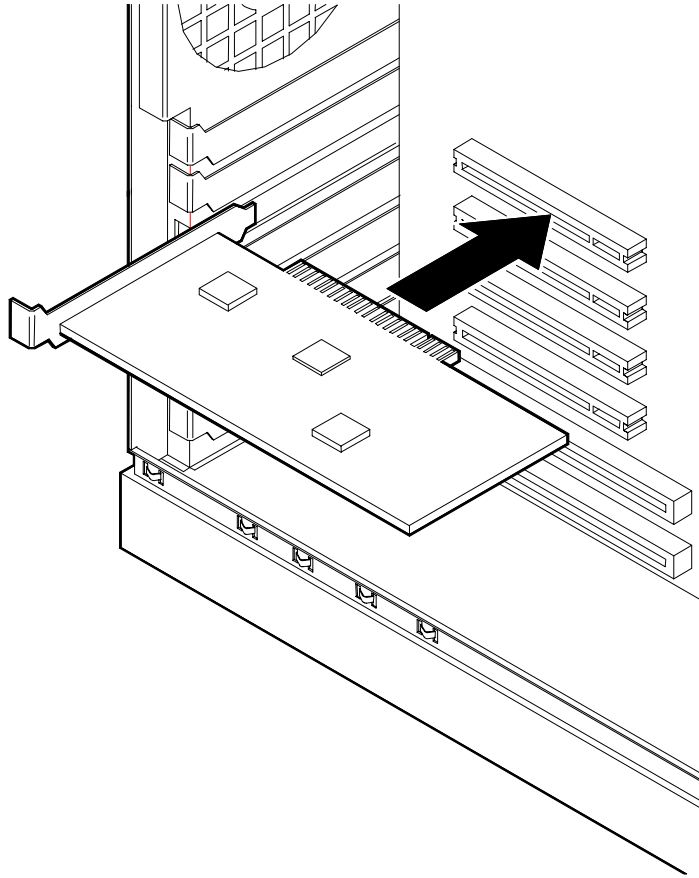

Installing an Option Board

9. Align the rounded notch in the option board retaining bracket with the alignment tab in the expansion slot frame. The retaining bracket fits into the space that was occupied by the expansion slot cover.
10. Be sure to push the bracket slot up against the expansion slot frame. If this is not done, the bracket may interfere with an adjacent bracket.
11. Install the previously removed expansion slot retainer bar by pressing its top fastener into the top of the expansion slot frame. The bottom tapered tab of the expansion slot retainer bar fits into the mating slot on the bottom of the expansion slot frame.
12. Connect any external cables (if they are needed) to the installed option board.
13. Replace the left side panel, plug in the system power cord, and power on the system.

Removing an Option Board

 **Note:** Expansion slot covers must be installed on all vacant slots to maintain the electromagnetic emissions characteristics of the system and to assure proper cooling of the system components.

1. Power off the system and remove the left side panel as described earlier in this chapter.
2. Disconnect any cables attached to the option board you are removing.
3. Remove and save the expansion slot retainer bar by pressing down on its top fastener and pulling the bar out.
4. Hold the board at each end and carefully rock it back and forth until the edge connectors pull free. Make sure that you do not scrape the board against other components.
5. Remove the board from the expansion slot and place it in an antistatic wrapper. If you are replacing a board, go to "Installing an Option Board" earlier in this chapter, otherwise continue.
6. Install an expansion slot cover over the vacant slot.
7. Install the previously removed expansion slot retainer bar by pressing its top fastener into the lock plate at the top of the expansion slot frame. The bottom tapered tab of the expansion slot retainer bar fits into the mating slot on the bottom of the expansion slot frame.
8. Replace the left side panel, plug in the system power cords, and power on the system.
9. If you removed a non-Plug-and-Play ISA option board, run the SSU to configure the system as described in the "Configuring Your System" chapter.

Installing a RAID Controller Board

Use this procedure to install a Mylex RAID controller board.

1. Install the RAID controller board into PCI slot 2 of the system board. See "Installing an Option Board" earlier in this chapter.
2. Cable the RAID controller board as described below (see "System Cabling" in Appendix A):
 - Remove the end of the SCSI interface cable that is plugged into the wide SCSI connector on the system board.
 - Reinstall the end of the SCSI interface cable just removed into the Channel 0 connector on the RAID board.

Hard Disk Drives

Your system supports a variety of SCSI hard disk drives. The SCSI drives must use the industry standard 80-pin Single Connector Attachment (SCA) connector. Contact your sales representative or dealer for a list of approved devices. The internal hard disk drives are located in the SCSI Disk Drive Bays (A).

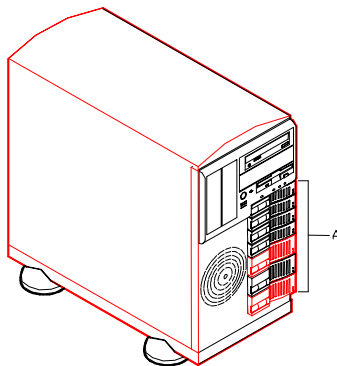

SCSI Disk Drive Bay Locations

If you are adding or removing a SCSI hard disk device, consider the following:

CAUTION

Do not hot swap a non-LVD-disk-drive into a LVD-disk-drive only system for it may cause data corruption. The only way a non-LVD-disk-drive can be used with an all LVD-disk-drive system is by first powering down the system, installing the non-LVD-disk-drive, and then powering the system back up.

 **Note:** Installing a non-LVD-disk-drive into an all LVD-disk-drive system causes all the drives to operate in the non-LVD mode.

- The onboard SCSI controller support single-ended drives. If a RAID controller board is installed it supports Low Voltage Differential (LVD) disks. The hard disk SCSI address assignment is:

| Bay | Device | SCSI ID Address |
|-----|-----------------------------------|-----------------|
| 1 | First 1.6 inch Hard Disk (Bottom) | 0 |
| 2 | Second 1.6 inch Hard Disk | 1 |
| 3 | Third 1.6 inch Hard Disk | 2 |
| 4 | Fourth 1.0 inch Hard Disk | 3 |
| 5 | Fifth 1.0 inch Hard Disk | 4 |
| 6 | Sixth 1.0 inch Hard Disk | 5 |
| 7 | Seventh 1.0 inch Hard Disk (Top) | 6 |

Installing or Swapping a Hard Disk Drive in a Hot-swap Bay

This procedure describes installing a new drive or swapping out a faulty drive from one of the seven hot-swap SCSI disk drive bays. The 3 1/2-inch SCSI drives must use the industry standard 80-pin Single Connector Attachment (SCA) connector. Each drive must be installed in a drive carrier.

 **Note:** To order a disk with a carrier, contact your sales representative or dealer.

- If installing new drives, follow an installation scheme starting with the bottom drive. Fill the bays bottom to top.
- If an individual SCSI drive fault LED (yellow light) is on steadily, this indicates that the drive has been flagged as faulty by the RAID host controller. Follow the procedure described in this section to remove the faulty drive and swap in a good one.

 **Note:** ESD can damage disk drives, boards, and other parts. This system can withstand normal levels of environmental ESD while you are hot-swapping SCSI hard drives. However, we recommend that you do all procedures in this chapter only at an ESD workstation or provide some ESD protection by wearing an antistatic wrist strap attached to chassis ground—any unpainted metal surface—on your system when handling parts.

CAUTION

Drive manufacturer's caution against moving a disk drive that is still spinning because of possible damage to the drive.

After you determine which drive has been flagged as faulty, the procedure is the same to swap a drive or to install one for the first time.

Installing or Swapping a Hard Disk Drive

1. Open the front door as described earlier in this chapter.
2. If installing a hard disk drive in a disk carrier for the first time, perform the following procedures:
 - Pull the handle (A) out of the disk carrier's front panel and remove the carrier's front panel from the SCSI hard disk drive bay.
 - Remove the two screws securing the retainer (B) to the back of the front panel and remove the retainer. Save the disk carrier's front panel retainer and two screws for future use.

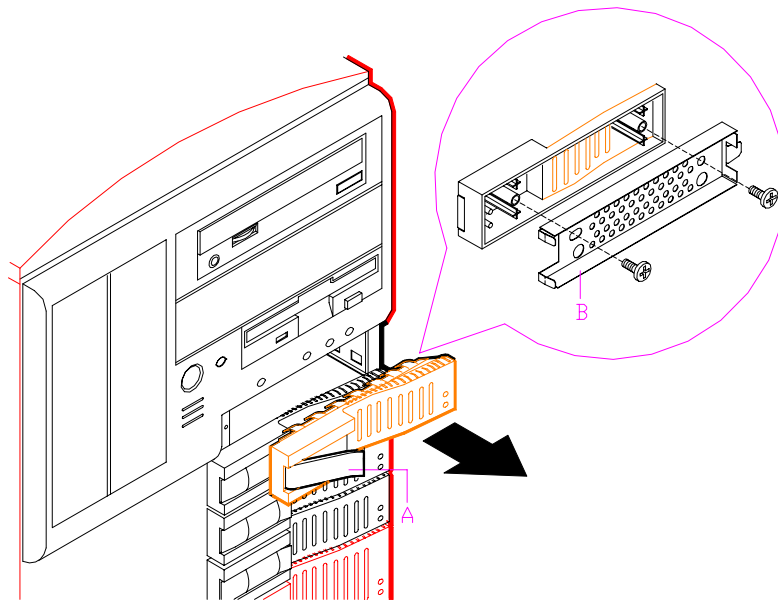

Removing the Disk Carrier's Front Panel

- Go to step 5.
3. If swapping a hard disk drive, remove its carrier from the SCSI hard disk drive bay by performing the following procedures:

CAUTION

Depending on the drive fault, the drive may be still spinning when you remove it. Follow the next steps exactly when removing drives.

- Pull the disk carrier handle out.
- Pull the faulty disk drive out of the bay by its outside edges far enough to disengage the drive connector from the backplane. Wait 30 seconds until the drive spins down.
- Remove the carrier from of the drive bay.

-
4. Remove the hard disk drive from the disk carrier.
 5. Remove the new drive from its protective wrapper, and place on an antistatic surface.



CAUTION

Observe static precautions. Use an antistatic wrist strap.

6. Record the drive model and serial numbers in the equipment log.
7. Before continuing with the next step, if you are installing a hard disk in a disk carrier for the first time, attach the front panel to the disk carrier's frame and secure it with the two screws removed in step 2.
8. Install the drive on the drive carrier.
 - Place the drive on the carrier, with its connector facing the back of the carrier.
 - Turn the drive and carrier over and secure the drive in the carrier with the four screws and one additional screw and EMI ground clip supplied with the disk drive. The EMI ground clip (A) is installed under the screw being installed on the left side toward the front of the carrier.

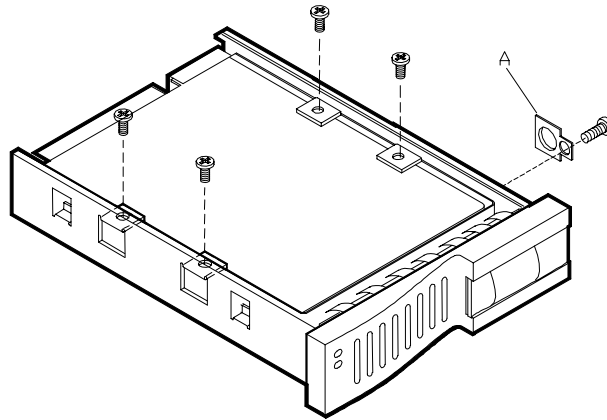

Securing the Drive in the Carrier

9. Install the drive carrier with drive into the bay as follows:
 - Close the drive carrier handle.
 - Align the drive carrier with the bay guide rails.
 - Slide the drive carrier into the bay until it docks with the SCSI backplane connector.

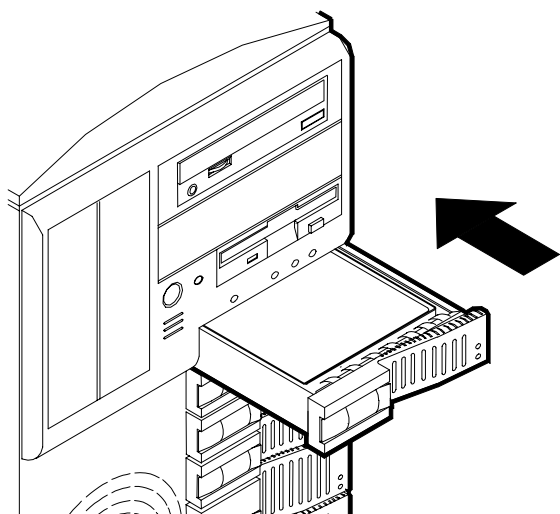

Installing a Disk Carrier into the Bay

- 10.** Close the front door on the system. If necessary, configure the system as described in Chapter 3 "Configuring Your System".

Removable Media Devices

A variety of IDE and SCSI removable media devices can be installed in peripheral bays A, B, C, D, and E. An IDE CD-ROM is always mounted in bay A. A 3.5-inch diskette drive is always mounted in bay C. Other devices should be installed in the first available bay from the top (bay B). Contact your sales representative or dealer for a list of approved devices.

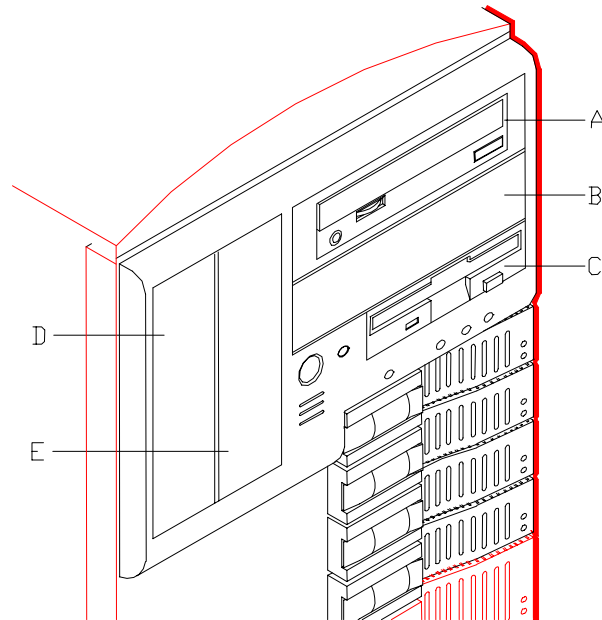

If you are adding or removing an IDE removable media device, consider the following:

- The system board supports a primary and secondary IDE channel connector. Each of these supports two devices, for a total of four IDE devices. Your system includes the primary channel IDE interface cable.
- A first (master) device and a second (slave) device are supported on both the primary and secondary IDE connector. Jumpers on the device determine the device configuration, master versus slave. Cable Sense (CS) device configuration is not supported.
- Your system includes a three-connector IDE cable connecting the CD-ROM to the system board primary IDE connector. The CD-ROM that comes with your system is set as the master device. A second IDE connector is available to connect a slave IDE removable media device.
- If only one device is on an IDE channel connector it must be set as the master device.

If you are adding or removing a SCSI removable media device, consider the following:

- The optional SCSI tape drive address assignment is 2.
- The SCSI termination resistors must be installed in the last SCSI drive of the daisy chain cabling. If the SCSI tape drive is your only SCSI device on the SCSI controller B, termination must be enabled in the tape drive.

Installing a 5.25-Inch Media Device

CAUTION

CD-ROM devices contain a laser system and are classified as CLASS 1 LASER PRODUCTS. To use these devices, thoroughly read the documentation provided by the CD-ROM manufacturer, and keep the documentation for future reference. In case of any trouble with a CD-ROM, please contact your nearest service representative. To prevent direct exposure to the laser beam, do not try to open the enclosure. Use of controls or adjustments or performance of procedures other than those specified in the CD-ROM manufacturer's documentation may result in hazardous radiation exposure

1. Power off the system, unplug the system power cords, and remove the appropriate side panel depending upon the bay you are installing the media device in and as described earlier in this chapter.
2. Open the front door as described earlier in this chapter.

CAUTION

Observe static precautions. Use an antistatic wrist strap.

3. Carefully remove the front system bezel by releasing its two plastic snap tabs on the back of the bezel and pulling it out (see Figure below).

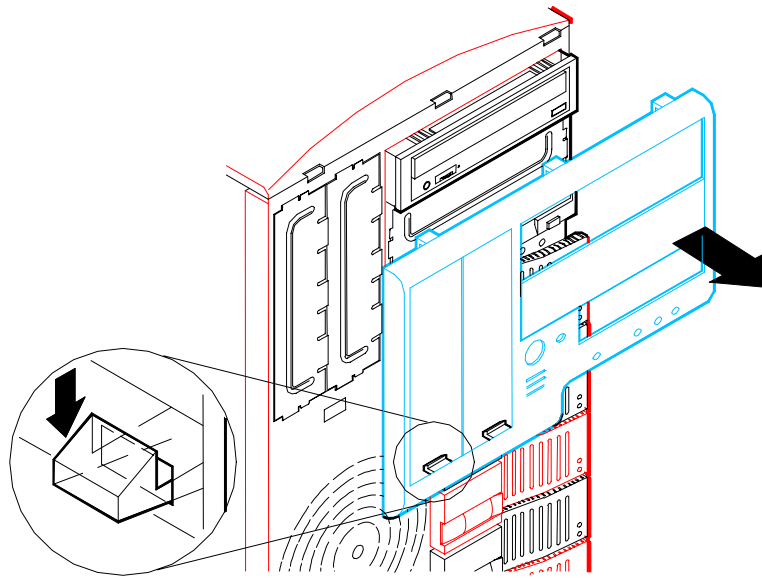

Removing the Front System Bezel

4. Remove the EMI metal shield covering the bay where you are installing a media device as shown below. The metal shield is removed by pulling on the tabs at the top and bottom of the metal shield.

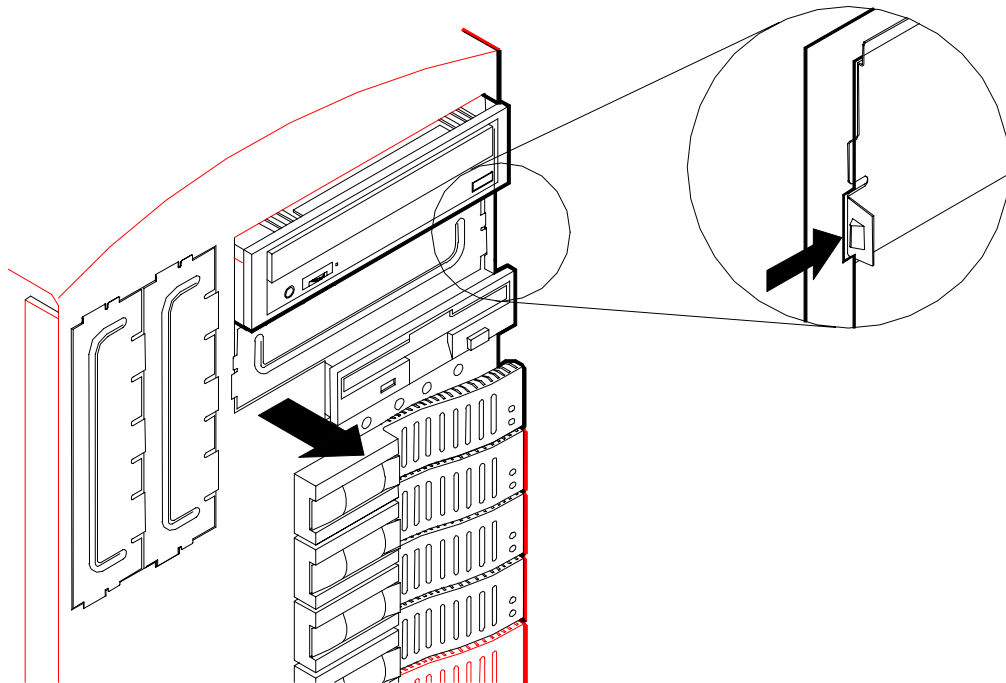

Removing an EMI Metal Shield

-
5. Remove the filler panel from the system bezel corresponding to the bay where you are installing a media device as shown below. The filler panel is released by pressing the plastic snap tabs located on the back of the system bezel. Save the panel for reinstallation.

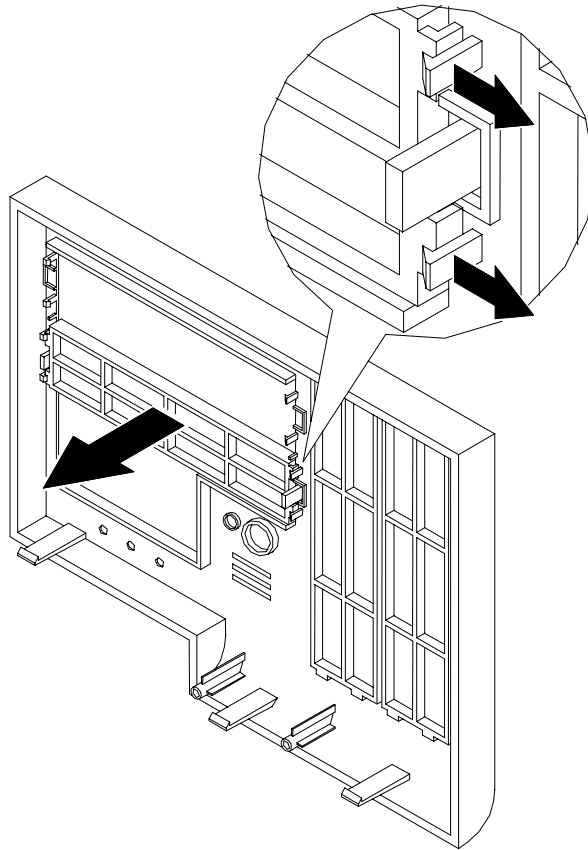

Removing a Filler Panel

6. Remove the device from its protective wrapper and place it on an antistatic surface. Record the drive model and serial number in the equipment log.
7. Set any drive jumpers or switches before you install the drive. See the documentation that comes with the device for jumper or switch information.

 **Note:** If the drive comes with drive rails, do not use them. Remove any rails already attached.

8. Attach the device side rails supplied with the system as shown below.

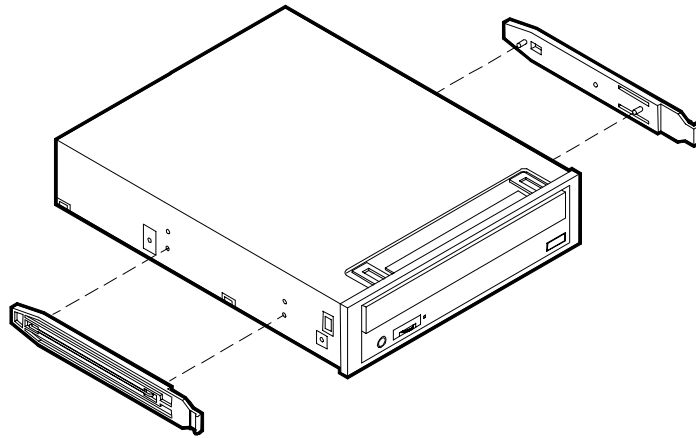

Attaching the Device Side Rails

9. Install the media device into the bay as follows:
- Move any cables in the bay out of the way.
 - Align the rails on the media device with the supports in the bay.
 - Slide the device into the bay until it locks in place.

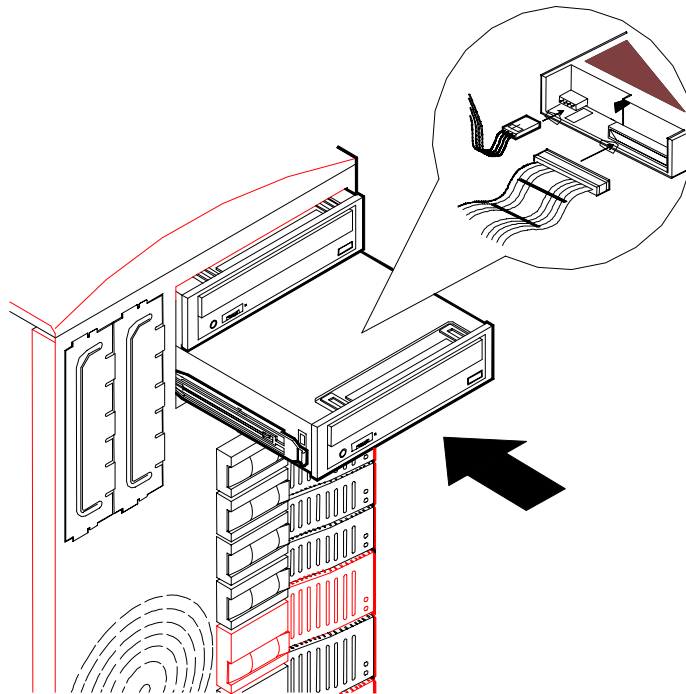

Installing a Removable Media Device

-
- 10.** Connect the interface and power cables to the device as follows (see Figure above):
- If you are installing a 5 1/4-inch tape drive or other IDE device, align and connect the drive signal cable and the system power cable to their connectors. The cable connector for the 5 1/4-inch device is keyed to fit only in the correct position. The red edge of the cable goes to pin 1 on the cable connector. Align the red edge of the connector with pin 1 (notched end) on the drive connector.
 - If you are installing a SCSI device, connect the SCSI cable and system power cable. Be sure to align the SCSI cable connector (not keyed) with the device connector.
- 11.** Carefully reinstall the front system bezel by inserting its top plastic tabs into the chassis top tab slots and then pushing its bottom portion straight in against the chassis (see Figure below).
- 12.** Close the front door, reinstall the side panel, and power on the system.

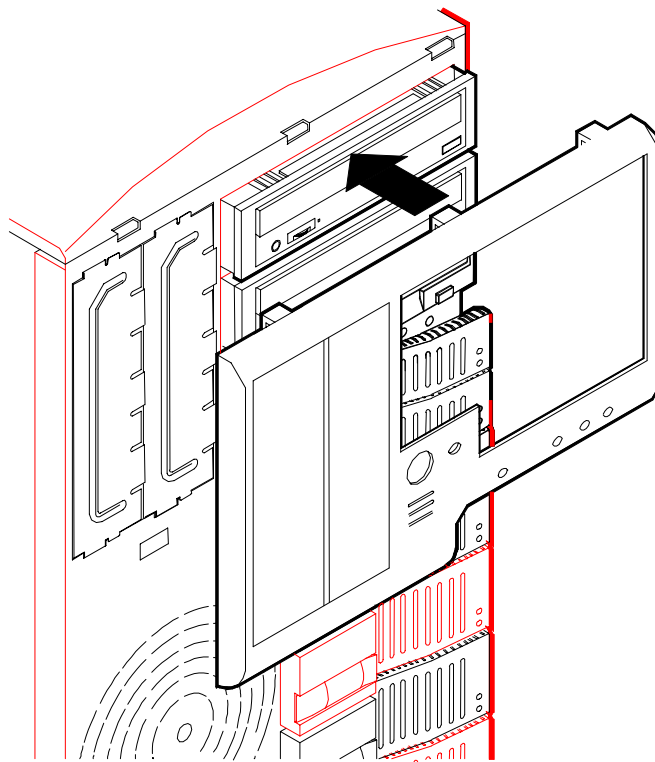

Installing the Front System Bezel

Removing a 5.25-Inch Device

1. Power off the system, unplug the system power cords, and remove the appropriate side panel depending upon the bay you are removing the media device from and as described earlier in this chapter.
2. Open the front door as described earlier in this chapter.
3. Observe static precautions. Use an antistatic wrist strap.



CAUTION

Observe static precautions. Use an antistatic wrist strap.

4. Carefully remove the front system bezel by releasing its two plastic snap tabs on the back of the bezel and pulling it out (see Figure below).

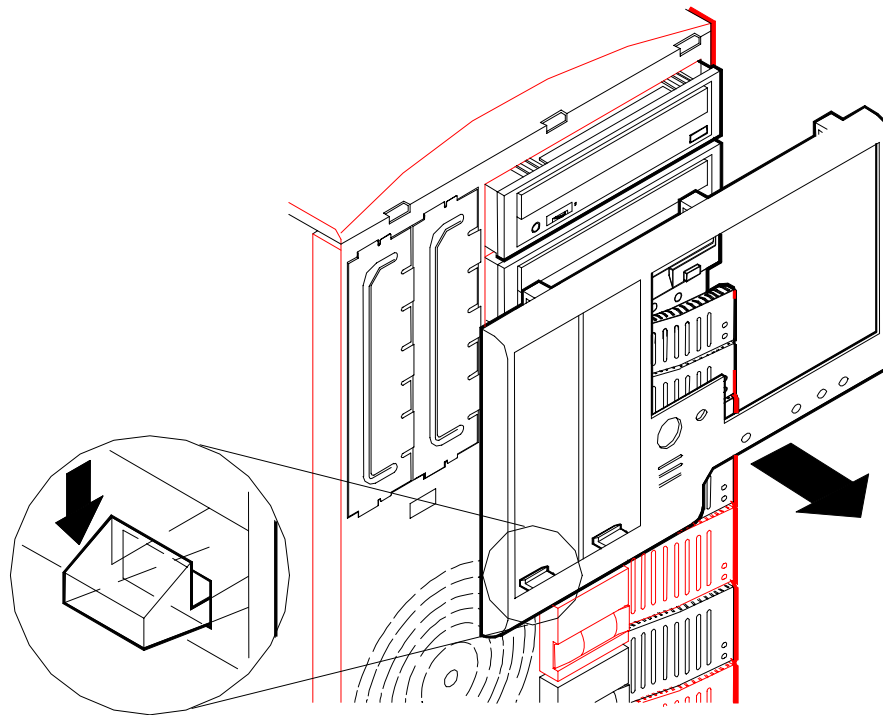

Removing the Front System Bezel

-
5. Disconnect the power cable (A) and ribbon data cable (B) from the device you are removing.

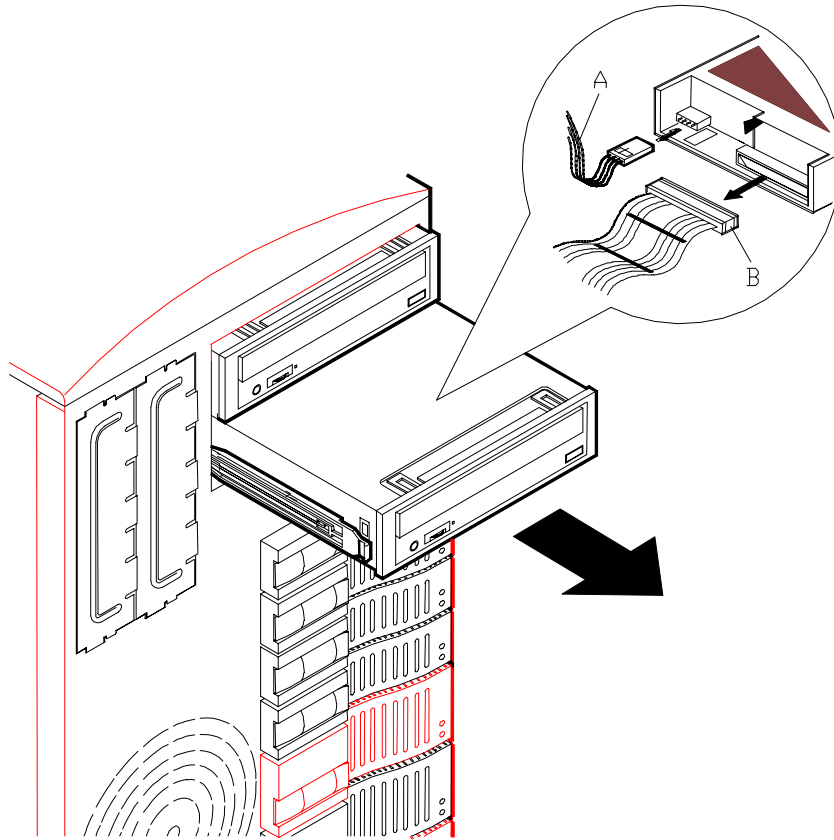

Removing a Removable Media Device

6. Remove the device from the peripheral bay by pushing in on its drive rail clips and pull the device completely out of the bay (see Figure above).
7. Install an EMI metal shield over the bay area where you removed the peripheral device. The EMI shield is secured by just snapping it into place.
8. Install a filler panel in the open area of the system bezel corresponding to the bay where the media device was removed.
9. Replace the side panel and front panel, and power on the system.
10. Remove the drive serial number from the equipment log.

5

Problem Solving

- Problem Solving
- Static Precautions
- Troubleshooting Checklists
- Additional Troubleshooting Procedures
- Specific Problems and Corrective Actions
- Problems with the Network
- PNP Installation Tips
- BIOS User's Information
- How to Identify BIOS and BMC Revision Levels

Problem Solving

This chapter helps you identify and solve problems that may occur during system installation or while using your system. The first section of this chapter tells you how to reset your system in the event of problems. The next few sections provide troubleshooting checklists and procedural steps that help you isolate specific system problems. The last section includes BIOS, system, and disk status user information.

WARNING

The DC push-button on/off switch on the front panel does not turn off the system AC power. Also, +5vdc is present on the system board whenever the AC power cord is connected between the system and an AC outlet. Before doing the procedures in this manual, make sure that your system is powered off and unplug the AC power cords from the back of the chassis. Failure to disconnect power before opening your system can result in personal injury and equipment damage

CAUTION

Operating your system with the side panels removed can damage your system components. For proper cooling and airflow, always replace the side panels before powering on your system.

Static Precautions

An electrostatic discharge (ESD) can damage disk drives, option boards, and other components. You can provide some ESD protection by wearing an antistatic wrist strap attached to chassis ground when handling system components.

Electronic devices can be easily damaged by static electricity. To prevent damage, keep them in their protective packaging when they are not installed in your system.

Troubleshooting Checklists

The following subsections provide troubleshooting checklists for problems that occur at initial system startup, when you run new application software, and after the system hardware and software have been running correctly.

Initial System Startup

Incorrect installation or configuration usually causes problems that occur at initial system startup. Hardware failure is a less frequent cause. If you have problems during initial system startup, check the following:

- Are the system power cords properly connected to the system and plugged into a NEMA 5-15R outlet (100-120 Vac) or a NEMA 6-15R outlet (200-240 Vac)?
- Is AC power available at the wall outlet?
- Is the power on/off push-button switch on the front panel in the ON position (power on LED should be lit)?
- Are all cables correctly connected and secured?
- Are all the PCI/ISA option boards fully seated in their connector slots on the system board?
- Are all jumpers and switch settings on option boards and peripheral devices correct? To check these settings, see the respective appendices. If applicable, ensure that there are no conflicts; for example, two option boards sharing the same interrupt.
- Are the processors fully seated in their slots on the system board? Refer to the “Upgrades and Options” chapter for installation instructions?
- Are all DIMMs fully seated and installed correctly? Refer to the “Upgrades and Options” chapter for installation instructions?
- Are all option boards and disk drives installed correctly? Refer to the “Upgrades and Options” chapter.
- Is the system hard disk drive properly formatted or defined?
- Is the operating system properly loaded? Refer to the operating system documentation.
- Are all drivers properly installed? For information about installing drivers, refer to your Network Operating System Configuration Guide.
- Are the configuration settings in BIOS Setup and the System Setup Utility (SSU) correct? For information about running these utilities, refer to the “Configuring Your System” chapter.

If the above items are all correct, but the problem reoccurs, refer to “Additional Troubleshooting Procedures” in this chapter.

Running New Application Software

Problems that occur when you run new application software are usually related to the software. Faulty equipment is much less likely, especially if other software runs correctly. If you have problems while running new application software, check the following:

- Does the system meet the minimum hardware requirements for the software? Refer to the software documentation.
- Is the software an authorized copy? Unauthorized copies often do not work. Obtain an authorized copy of the software.
- If you are running the software from a diskette, is it a good copy?
- If you are running the software from a hard disk drive, is the software correctly installed? Were all necessary procedures followed and files installed?
- If you are running the software from a CD-ROM disk is the disk scratched or dirty?
- Are the correct device drivers installed?
- Is the software correctly configured for the system?
- Are you using the software correctly?
- If other software runs correctly on the system, contact your vendor about the failing software.

If the problems persist with the software, contact the software vendor's customer service representative.

After System Has Been Running Correctly

Problems that occur after the system hardware and software have been running correctly often indicate equipment failure. However, many situations that are easy to correct can also cause such problems. If you have problems after the system has been running correctly, check the following:

- If you are running the software from a diskette or CD-ROM, try a new copy of the software.
- If you are running the software from a hard disk drive, try running it from a floppy. If the software runs correctly, there may be a problem with the copy on the hard disk. Reinstall the software on the hard disk drive and try running it again. Make sure all the necessary files are installed.
- If the problem recurs, you may need to reformat the hard disk drive. The hard disk drive, the drive controller, or the system board may be defective.
- If the problems are intermittent, there may be a loose cable, dirt in the keyboard (if keyboard input is incorrect), a marginal power supply, or other random component failures.
- If you suspect that a transient voltage spike, power outage, or brownout might have occurred, reload the software and try running it again. Symptoms of voltage spikes include a flickering video display, unexpected system reboots, and the system not responding to user commands.

 **Note:** Voltage spikes can corrupt or destroy data files on the drive. If you are experiencing voltage spikes on the power line, install a surge suppresser between the power outlet and the system power cord.

If the problem recurs after you have checked and corrected all of the above items, refer to “Additional Troubleshooting Procedures” in this chapter.

Additional Troubleshooting Procedures

This section provides a more detailed approach to diagnostic testing and identification of a problem and locating its source.

Use the following troubleshooting procedures to help you identify a problem. These general procedures lead you through the following:

- Preparing the system for diagnostic testing
- Monitoring POST while it is running
- Verifying proper operation of key system LEDs
- Confirming loading of the operating system.

Preparing the System for Diagnostic Testing

To prepare the system for diagnostic testing, perform the following:

 **Note:** Before disconnecting any peripheral cables from the system, turn off the system and any external peripheral devices. Failure to do so can cause permanent damage to the system and/or the peripheral devices.

1. Turn off the system and all external peripheral devices. Disconnect all devices from the system except the keyboard and video monitor.
2. Make sure the system power cords are plugged into a properly grounded AC outlet.
3. Make sure your video display monitor and keyboard are correctly connected to the system. Turn on the video monitor. Set its brightness and contrast controls to at least two-thirds of their maximum ranges (refer to the documentation supplied with your video display monitor).
4. If the operating system normally loads from the hard disk drive, make sure there is no diskette in drive A. Otherwise, place a diskette containing the operating system files in drive A.
5. Turn on the system. If the power indicator LED does not light, refer to “Power Light Does Not Light” found later in this chapter.

Monitoring POST

Each time you turn on the system, the Power-On Self-Test (POST) runs automatically and checks the system board, processor board, memory, keyboard, and most installed peripheral devices.

During the memory test, POST displays the amount of memory that it is able to access and test. Depending on the amount of memory, it may take several minutes to complete the memory test.

Press **F2** to enter SETUP. If you do not press **F2**, the above message remains for a few seconds and the boot process continues.

If POST finds an error, it displays an error message and, in case there is a problem with the display, it emits a series of long and short beeps. Write down any beep code emitted. This information is useful to your service representative.

Refer to the “BIOS User’s Information” section in this chapter for a list of items to check for each error code and for an explanation of the error beep codes.

The POST Tests table at the end of this chapter lists keys active during POST and provides a description of errors that may occur.

The BIOS indicates errors by writing an error code to the PS/2-standard logging area in the Extended BIOS Data Area, and by displaying a message on the screen, which is sometimes preceded by the POST Error Code. The error code will also be logged to the Event Logging area.

Report any error code to your service representative.

POST Keys and Errors

| Action/Message | Description |
|------------------------------------|--|
| If POST Beeps Before Video Appears | Initialization failed before video initialized. Most beep code errors are fatal; initialization cannot continue. Refer to the section “BIOS User’s Information” in this chapter. |
| If Monitor Displays Error | Note error; press F1 to continue boot or F2 to enter Setup. Refer to the section “BIOS User’s Information” in this chapter. |
| To Enter Setup | Setup changes specific options, then writes to CMOS, NVRAM. Press F2 during initialization to run Setup. If you do not press F2 , the boot process continues. |
| Enter BOOT Diskette | If prompted, insert the boot diskette. |

Verifying Proper Operation of Key System Indicators

As POST determines the system configuration, it tests for the presence of each mass storage device installed in the system. As each device is checked, its activity indicator should turn on briefly. Check for the following:

- Does the diskette drive activity indicator turn on briefly? If not, refer to “Diskette Drive Activity Indicator Does Not Light” in this chapter.
- If a second diskette drive is installed, does its activity indicator turn on briefly? If not, refer to “Diskette Drive Activity Indicator Does Not Light” in this chapter.
- If there is a hard disk drive or SCSI devices installed in the system, does the hard disk drive activity indicator turn on briefly? If not, refer to “Hard Disk Drive Activity Indicator Does Not Light” in this chapter.

Confirming Loading of the Operating System

Once the system boots up, the operating system prompt appears on the screen. The prompt varies according to the operating system. If the operating system prompt does not appear, refer to “Problems with Application Software” found later in this chapter.

Specific Problems and Corrective Actions

This section provides possible solutions for the following specific problems:

- Power LED does not light
- No beep or incorrect beep pattern
- No characters appear on screen
- Characters on the screen appear distorted or incorrect
- System cooling fan does not rotate
- Diskette drive activity LED does not light
- Hard disk drive activity LED does not light
- CD-ROM drive activity LED does not light
- Problems with application software
- The startup prompt “Press <F2> key if you want to run Setup” does not appear on the screen.
- The bootable CD-ROM is not detected.
- The SSU does not boot

Try the solutions in the order given. If you cannot correct the problem, contact your service representative for assistance.

Power LED Does Not Light

Check the following:

- Is the system operating normally? If so, the power LED is probably defective.
- Are there other problems with the system? If so, check the items listed under System Cooling Fans Do Not Rotate.

Incorrect or No Beep Code

Check the following:

- Is the speaker enabled?
- Is the speaker cable connected to the system board?

If the system operates normally, but there was no beep, the speaker may be defective, contact your service representative for assistance.

Record the beep code emitted by POST, and see the “Messages and Beep Codes” section found later in this chapter.

No Characters Appear on Screen

Check the following:

- Is the keyboard working? Check to see if the **Num Lock** light is functioning.
- Is the video display monitor plugged in and turned on?
- Are the brightness and contrast controls on the video monitor properly adjusted?
- Are the video monitor switch settings correct?
- Is the video monitor signal cable properly installed?

- Is the onboard video controller enabled?

If you are using an option video controller board, perform the following:

1. Verify that the video controller board is fully seated in the system board connector.
2. Run the SSU to disable the onboard video controller.
3. Reboot the system for changes to take effect.

If there are still no characters on the screen after you reboot the system, contact your service representative or authorized dealer for assistance.

POST emits one long beep and two short beeps pattern to indicate a possible problem with the video display controller. If you do not receive a beep pattern and characters do not display, the video display or video controller may have failed. Contact your service representative or authorized dealer for assistance.

Characters are Distorted or Incorrect

Check the following:

- Are the brightness and contrast controls properly adjusted on the video display? Refer to the documentation supplied with your video display.
- Are the video monitor's signal and power cables properly installed?
- If the problem persists, the video monitor may be faulty or it may be the incorrect type. Contact your service representative for assistance.

System Cooling Fans Do Not Rotate

 **Note:** The system has a cooling fan module (containing either two or three fans) behind the hard disk drives. In addition, there are two fans one directly in front of and one directly behind the system board, including a place reserved for an optional fan directly under the rear fan, and another cooling fan that is an integral part of each power supply. There are no serviceable components inside the power supply. If the power supply is opened, the manufacturer's warranty is voided.

Check the following:

- Is AC power available at the wall outlet?
- Are the system power cords properly connected to the power supplies and the AC wall outlets?
- Are the power connectors for the cooling fan module and fans connected to the system board?
- Is the front panel power on indicator lit?

If the switches and connections are correct and the power outlet is functioning, the power supply has probably failed. Contact your service representative for assistance.

Diskette Drive Activity LED Does Not Light

Check the following:

- Are the diskette drive's power and signal cables properly installed?
- Is the diskette drive properly configured?
- Is the diskette drive activity light always on? If so, the signal cable may be plugged in incorrectly.

If you are using the onboard diskette controller, use Setup or the SSU to make sure that Onboard Floppy is set to Enabled. Conversely, to use an optional fixed/diskette controller, make sure that Onboard Floppy is set to **Disabled**. For information about running Setup or the SSU, refer to the "Configuring Your System" chapter.

If the problem persists, there may be a problem with the diskette drive, system board, or drive signal cable. Contact your service representative for assistance.

CD-ROM Drive Activity Light Does Not Light

Check the following:

- Is the power and signal cable to the CD-ROM drive properly installed?
- Are all relevant switches and jumpers on the drive set correctly?
- Is the drive properly configured?
- Is the onboard IDE controller enabled?

Problems with Application Software

If you have problems with application software, perform the following:

- Verify that the software is properly configured for the system. Refer to the software installation and operation documentation for instructions on setting up and using the software.
- Verify a different copy of the software to see if the problem is with the copy that you are using.
- Make sure all cables are installed correctly.
- Verify that the system board jumpers are set correctly. Refer to the “Configuring Your System” chapter for jumper settings.
- If other software runs correctly on the system, contact your vendor about the failing software.

If the problem persists, contact the software vendor's customer service representative for assistance.

Press F2 Key to Enter Setup: Prompt Does Not Display

If the prompt “Press F2 key to run Setup” does not appear at system startup, then the prompt option has been disabled in the SSU. To enable the prompt:

- Reboot the system using your SSU diskette 1, and go into the SSU to enable the prompt.

Enable F2 Prompt by Using SSU

1. Insert your SSU diskette in the diskette drive. This is the diskette that is created by copying the SSU software from EXPRESSBUILDER CD-ROM that comes with the system.
2. Reboot the system by pressing **Ctrl+Alt+Del** while at the DOS operating system prompt *or* by pressing the reset switch.
3. When the DOS Startup menu appears, select 1 or 2 to enter the SSU.
4. Select Step 3, "Change Configuration Settings." If a password menu displays, enter a user or administrative password if either is enabled, or just press **ESC** to bypass this menu prompt.
5. Select the System Board.
6. Page down until you reach the Boot Subsystem Group. It is toward the end of the groups.
7. Find and select the option that says, "Display 'F2 for Setup' Message during POST."
8. Press **Enter** to display the option menu.
9. Select **Enable** and press **Enter**.
10. If you are finished editing the settings for the system board, press **Esc**. This takes you back up to the main menu, Step 3.
11. Press **Esc** again to return to the main SSU menu.
12. Select Step 4, Save Configuration. Once you select this step, the changes are immediately saved into an INF file, a CMS file, and nonvolatile memory.
13. Press **Esc** to exit the SSU. You will be prompted to reboot the system or simply exit to the command line prompt. You'll need to reboot the system to let your changes take effect, but *first* remove the SSU diskette drive. *Then* press **F10** to reboot.

You should now see the **F2** prompt displayed at bootup.

Enable F2 Prompt by Changing a Jumper and Using SSU

If you do not have an SSU diskette or CD available, you can clear CMOS memory to enable the **F2** prompt. This means you must change a jumper on the system board, run the SSU, save your changes, and change the jumper back to the default setting.

CAUTION

This procedure resets all to default settings: Clearing CMOS memory resets *all* SSU and Setup settings to their defaults, not just the CMOS CLR setting. Before proceeding, check that you have a backup paper copy of configuration. Referring to the worksheets could make your reconfiguration task easier.

1. Observe the safety and ESD precautions stated at the beginning of this chapter.
2. Turn off all connected peripherals, turn off system power, and disconnect the AC power cord.
3. Remove the side cover. Refer to the “Upgrades and Options” chapter for information on removing the side cover. You do not need to remove the system board from the chassis, and you probably do not need to remove any add-in boards.
4. Locate the CMOS configuration jumper at the edge of the system board toward the front of the system. Refer to the “Configuring Your System” chapter for information on the location of the CMOS jumper.
5. Move the CMOS CLR jumper from the CMOS Protect setting on pins 1 and 2 to the CMOS Clear setting on pins 2 and 3.
6. Reinstall the side cover for your safety, and connect the power cord to the system.
7. Power on the system. POST starts and halts displaying an “Invalid CMOS Settings” error.
8. Turn off the system, and disconnect the power cords.
9. Again remove the side cover.
10. Move the CMOS CLR jumper from pins 2 and 3 back to pins 1 and 2 (the Protect CMOS memory position).
11. Reinstall the side cover, and connect the power cords.
12. Turn the system on. Run BIOS Setup (F2) to verify the correct settings. Refer to Chapter 3 for information on running BIOS Setup.

Bootable CD-ROM Is Not Detected

Check the following:

- Is the BIOS set to allow the CD-ROM to be the first bootable device? Check your BIOS Setup (F2) configuration.

Problems with the Network

The server hangs when the drivers are loaded:

- Change the PCI BIOS interrupt settings. Try the “PCI Installation Tips” below.

Diagnostics pass, but the connection fails:

- Make sure the network cable is securely attached.
- Make sure you specify the correct frame type in your NET.CFG file.

The Link LED doesn't light:

- Make sure you have loaded the network drivers.
- Check all cable connections.
- Try another port on the hub.
- Make sure you have the correct type of cable between the adapter and the hub. Some hubs require a crossover cable while others require a straight-through cable (for more information on crossover cabling, see your hub documentation).

The Activity LED doesn't light:

- Make sure you've loaded the correct network drivers.
- Network may be idle. Try accessing a server.

The controller stopped working when an add-in adapter was installed:

- Make sure the cable is connected to the port from the onboard network controller.
- Make sure your PCI BIOS is current. Try the “PCI Installation Tips” below.
- Make sure the other adapter supports shared interrupts. Also, make sure your operating system supports shared interrupts; OS/2 does not.
- Try reseating the add-in adapter.

The add-in adapter stopped working without apparent cause.

- Try reseating the adapter first; then try a different slot if necessary.
- The network driver files may be corrupt or deleted. Delete and then reinstall the drivers.
- Run the diagnostics.

PNP Installation Tips

Some common PCI tips are listed here.

- Reserve interrupts (IRQs) and/or memory addresses specifically for ISA adapters. This prevents PCI cards from trying to use the same settings ISA cards are using. Use the SSU to keep track of ISA adapter resources.
- Certain drivers may require interrupts that are not shared with other PCI drivers. The SSU can be used to adjust the interrupt numbers for PCI devices. For certain drivers, it may be necessary to alter settings so that interrupts are not shared.

BIOS User's Information

This section describes the various screen messages and beep codes of the system BIOS. The BIOS indicates errors by writing an error code to the PS/2-standard logging area in the Extended BIOS Data Area, and by displaying a message on the screen, which is sometimes preceded by the POST Error Code. The error code will also be logged to the Event Logging area.

 **Note:** Your system error log will be lost, if your system ac power source is off or disconnected.

Error and Status Messages

“BIOS Messages” table is an alphabetic list of error and status messages that BIOS generates and an explanation of each message. Many of the messages refer to the built in Setup program. For more information about Setup, refer to the “Configuring Your System” chapter.

BIOS Messages

| Message | Description |
|--|--|
| <i>nnnn</i> Cache SRAM Passed | Where <i>nnnn</i> is the amount of system cache in kilobytes successfully tested. |
| Diskette drive A error or Diskette drive B error | Diskette Drive is present but fails the BIOS POST diskette tests. Check to see that the drive is defined with the proper diskette type in Setup and that the diskette drive is correctly attached. |
| Entering SETUP ... | The Setup program is starting. |
| Extended RAM Failed at offset: <i>nnnn</i> * | Extended memory is not working or is not properly configured at offset <i>nnnn</i> . |
| <i>nnnn</i> Extended RAM passed | Where <i>nnnn</i> is the amount of RAM in kilobytes successfully tested. |
| Failing Bits: <i>nnnn</i> * | The hex number <i>nnnn</i> is a map of the bits at the RAM address (in System, Extended, or Shadow memory) which failed the memory test. Each 1 (one) in the map indicates a failed bit. |
| Fixed Disk 0 Failure or Fixed Disk 1 Failure or Fixed Disk Controller Failure* | Fixed disk is not working or not properly configured. Check to see if the fixed disk is attached properly. Run Setup to be sure the fixed disk type is correctly identified. |
| Incorrect Drive A type - run SETUP or Incorrect Drive B type - run SETUP | Type of floppy drive is not correctly identified in Setup. |
| Invalid NVRAM media type* | Problem with NVRAM (CMOS) access. |
| Keyboard controller error* | The keyboard controller test failed. You may have to replace the keyboard or controller. |
| Keyboard error <i>nn</i> | The keyboard is not working. BIOS discovered a stuck key and displays the scan code <i>nn</i> for the stuck key. |
| Monitor type does not match CMOS - Run SETUP | Monitor type is not correctly identified in Setup. |
| Operating system not found | The operating system cannot be located on either drive A: or drive C:.. Enter Setup and see if the fixed disk and floppy are properly identified. |

*If your system displays this message, write down the message and notify your customer representative. If your system fails after you made changes in the BIOS Setup menus, you may be able to correct the problem by entering Setup and restoring the original values.

BIOS Messages (Continued)

| Message | Description |
|--|---|
| Parity Check 1 <i>nnnn</i> * or Parity Check 2 <i>nnnn</i> * | A parity error was found in the system bus (Parity Check 1) or the I/O bus (Parity Check 2). BIOS attempts to locate and display the address on the screen. If it cannot locate the address, it displays. |
| Press <F1> to resume, <F2> to Setup | Displayed after any recoverable error message. |
| Press <F2> to enter SETUP | Optional message displayed during POST. Can be turned off in Setup. |
| Previous boot incomplete - Default configuration used | Previous POST did not successfully complete. POST loads default values and offers to run Setup. If the failure was caused by incorrect values and they are not corrected, the next boot will likely fail. On systems with control of wait states, improper Setup settings can also terminate POST and cause this error on the next boot. Run Setup and verify that the wait-state configuration is correct. This error is cleared the next time the system is booted. |
| Real time clock error* | Real time clock fails BIOS test. May require board repair. |
| Shadow Ram Failed at offset: <i>nnnn</i> * | Shadow RAM failed at offset <i>nnnn</i> of the 64K block at which the error was detected. |
| <i>nnnn</i> Shadow RAM Passed | Where <i>nnnn</i> is the amount of shadow RAM in kilobytes successfully tested. |
| System battery is dead - Replace and run SETUP | The CMOS clock battery indicator shows the battery is dead. Replace the battery and run Setup to reconfigure the system. |
| System BIOS shadowed | The system BIOS is copied to shadow RAM. |
| System cache error - Cache disabled* | The RAM cache failed the BIOS test and BIOS has disabled the cache. |
| System CMOS checksum bad - run SETUP | The system CMOS has been corrupted or incorrectly modified, perhaps by an application program that changes data stored in CMOS. Run Setup and reconfigure the system either by getting the default values or making your own selections. |
| System RAM failed at offset: <i>nnnn</i> * | The system RAM failed at offset <i>nnnn</i> of the 64K block at which the error was detected. |
| <i>nnnn</i> System RAM Passed | Where <i>nnnn</i> is the amount of system RAM in kilobytes successfully tested. |

BIOS Messages (Continued)

| Message | Description |
|--|---|
| System timer error* | The timer test failed. Requires repair of the system board. |
| UMB upper limit segment address: <i>nnnn</i> | Displays the address <i>nnnn</i> of the upper limit of the Upper Memory Blocks, indicating released segments of the BIOS, which may be reclaimed by a virtual memory manager. |
| Video BIOS shadowed | The video BIOS is successfully copied to shadow RAM. |

*If your system displays this message, write down the message and notify your customer representative. If your system fails after you made changes in the BIOS Setup menus, you may be able to correct the problem by entering Setup and restoring the original values.

POST Error Codes and Messages

Whenever a recoverable error occurs during POST, BIOS displays a message on the video display screen and causes the speaker to beep as the message appears. The “POST Error Codes and Messages” table is a list of the error codes and messages written at the start of each POST test.

POST Error Codes and Messages

| Code | Error Message |
|-------------|---|
| 0162 | BIOS unable to apply BIOS update to processor 1 |
| 0163 | BIOS unable to apply BIOS update to processor 2 |
| 0164 | BIOS does not support current stepping for processor 1 |
| 0165 | BIOS does not support current stepping for processor 2 |
| 0200 | Failure Fixed Disk |
| 0210 | Stuck Key |
| 0211 | Keyboard error |
| 0212 | Keyboard Controller Failed |
| 0213 | Keyboard locked - Unlock key switch |
| 0220 | Monitor type does not match CMOS - Run SETUP |
| 0230 | System RAM Failed at offset |
| 0231 | Shadow RAM Failed at offset |
| 0232 | Extended RAM Failed at offset |
| 0250 | System battery is dead - Replace and run SETUP |
| 0251 | System CMOS checksum bad - Default configuration used |
| 0260 | System timer error |
| 0270 | Real time clock error |
| 0297 | ECC Memory error in base (extended) memory test in Bank xx |
| 02B2 | Incorrect Drive A type - run SETUP |
| 02B3 | Incorrect Drive B type - run SETUP |
| 02D0 | System cache error - Cache disabled |
| 02F5 | DMA Test Failed |
| 02F6 | Software NMI Failed |
| 0401 | Invalid System Configuration Data - run configuration utility |
| None | System Configuration Data Read Error |
| 0403 | Resource Conflict |
| 0404 | Resource Conflict |

Post Error Codes and messages (Continued)

| Code | Error Message |
|-------------|--|
| 0405 | Expansion ROM not initialized |
| 0406 | Warning: IRQ not configured |
| 0504 | Resource Conflict |
| 0505 | Expansion ROM not initialized |
| 0506 | Warning: IRQ not configured |
| 0601 | Device configuration changed |
| 0602 | Configuration error - device disabled |
| 8100 | Processor 1 failed BIST |
| 8101 | Processor 2 failed BIST |
| 8104 | Processor 1 Internal Error (IERR) failure |
| 8105 | Processor 2 Internal Error (IERR) failure |
| 8106 | Processor 1 Thermal Trip failure |
| 8107 | Processor 2 Thermal Trip failure |
| 8108 | Watchdog Timer failed on last boot |
| 810A | Processor 2 failed initialization on last boot |
| 810B | Processor 1 failed initialization on last boot |
| 810C | Processor 1 disabled, system in Uni-processor mode |
| 810D | Processor 2 disabled, system in Uni-processor mode |
| 810E | Processor 1 failed FRB level 3 timer |
| 810F | Processor 2 failed FRB level 3 timer |
| 8110 | Server Management Interface failed to function |
| 8120 | IOP subsystem is not functional |
| 8150 | NVRAM Cleared by Jumper |
| 8151 | NVRAM Checksum Error, NVRAM cleared |
| 8152 | NVRAM Data Invalid, NVRAM cleared |

How to Identify BIOS and BMC Revision Levels

To help you identify your system's current BIOS and BMC revision levels, refer to the following subsections.

BIOS Revision Level Identification

During system Power-On Self Test (POST), which runs automatically when your system is powered on, your system monitor displays several messages, one of which identifies the BIOS revision level currently loaded on your system, see example below.

Example: BIOS Revision Level

N440BX Production Release 11.0 - Build 76

In the example above, BIOS 11 is the current BIOS revision level loaded on your system.

BMC Revision Level Identification

During system Power-On Self Test (POST), which runs automatically when your system is powered on, system diagnostics are run. Following the memory test diagnostic, several messages will appear informing you that the keyboard and mouse were detected, when you see these messages you can press F2 to enter the setup utility.

To identify your system's current BMC revision level, perform the following steps.

1. Select "Server" from the menu bar.
2. Choose the "System Management" submenu.
3. Choose "Server Management Info" submenu.
4. Your current BMC revision level is the last two digits of the BMC revision field.

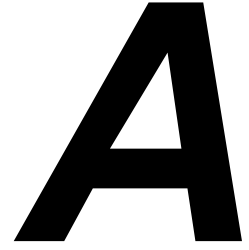

System Cabling

- System Cabling
- Before You Begin
- Static Precautions
- Standard Configuration
- RAID Configuration

System Cabling

This appendix contains information and procedures on cabling configurations used in your system.

The cabling configurations include:

- Standard Configuration
- RAID Configuration.

Before You Begin

WARNING

The DC push-button on/off switch on the front panel does not turn off the system AC power. Also, +5vdc is present on the system board whenever the AC power cords are connected between the system and an AC outlet. Before doing the procedures in this manual, make sure that your system is powered off and unplug the AC power cords from the back of the chassis. Failure to disconnect power before opening your system can result in personal injury and equipment damage.

Static Precautions

An electrostatic discharge (ESD) can damage disk drives, option boards, and other components. You can provide ESD protection by wearing an antistatic wrist strap attached to chassis ground when handling system components.

Electronic devices can be easily damaged by static electricity. To prevent damage, keep them in their protective packaging when they are not installed in your system.

Standard Configuration

Your system is cabled using a dual channel on-board IDE Controller and dual on-board Symbios Logic SYM53C875 SCSI Controllers.

The on-board IDE controller supports the standard internally mounted CD-ROM as its first (master) device and an optional internally mounted IDE tape drive as its second (slave) device.

The SYM53C875 contains two independent SCSI controllers that share a single PCI bus master interface. Internally, each controller is identical, capable of operations using either 8- or 16-bit SCSI providing 10 MB/s (Fast-10) or 20 MB/s (Fast-20) throughput, or 20 MB/s (Ultra) or 40 MB/s (Ultra-wide) throughput. As implemented on the system board controller A attaches to an Ultra-2 SCSI backplane that supports up to seven Ultra-2 SCA drives. Controller B may be used to support SCSI devices in the removable media bays.

A 3.5-inch diskette drive is also installed in all systems and interfaces separately to the system board.

Referring to the Figure below, a 68-pin wide SCSI interface cable (D) is connected to the SCSI connector (E) in the lower middle of the system board. This cable connects to the rear of the hard disk drive's SCSI backplane (C).

The IDE interface cable (J) is connected to the IDE connector (I) towards the right edge of the system board. This cable connects to the rear of the internally mounted CD-ROM drive (K).

Optional internally mounted SCSI removable media devices (P) may be connected to the SCSI controller connector (N) or optional internally mounted IDE removable media devices (M) may be connected to the secondary IDE controller connector (L).

When adding or removing IDE devices, consider the following:

 **Note:** Only one IDE cable is supplied with the system.

- The system board supports a primary and secondary IDE channel connector. Each of these supports two devices, for a total of four IDE devices.
- A first (master) device and a second (slave) device are supported on both the primary and secondary IDE channel connector.
- The device configuration, master versus slave, is determined by jumpers on the devices. Cable Sense (CS) device configuration is not supported.
- If only one device is on a channel connector it must be set as the master device.

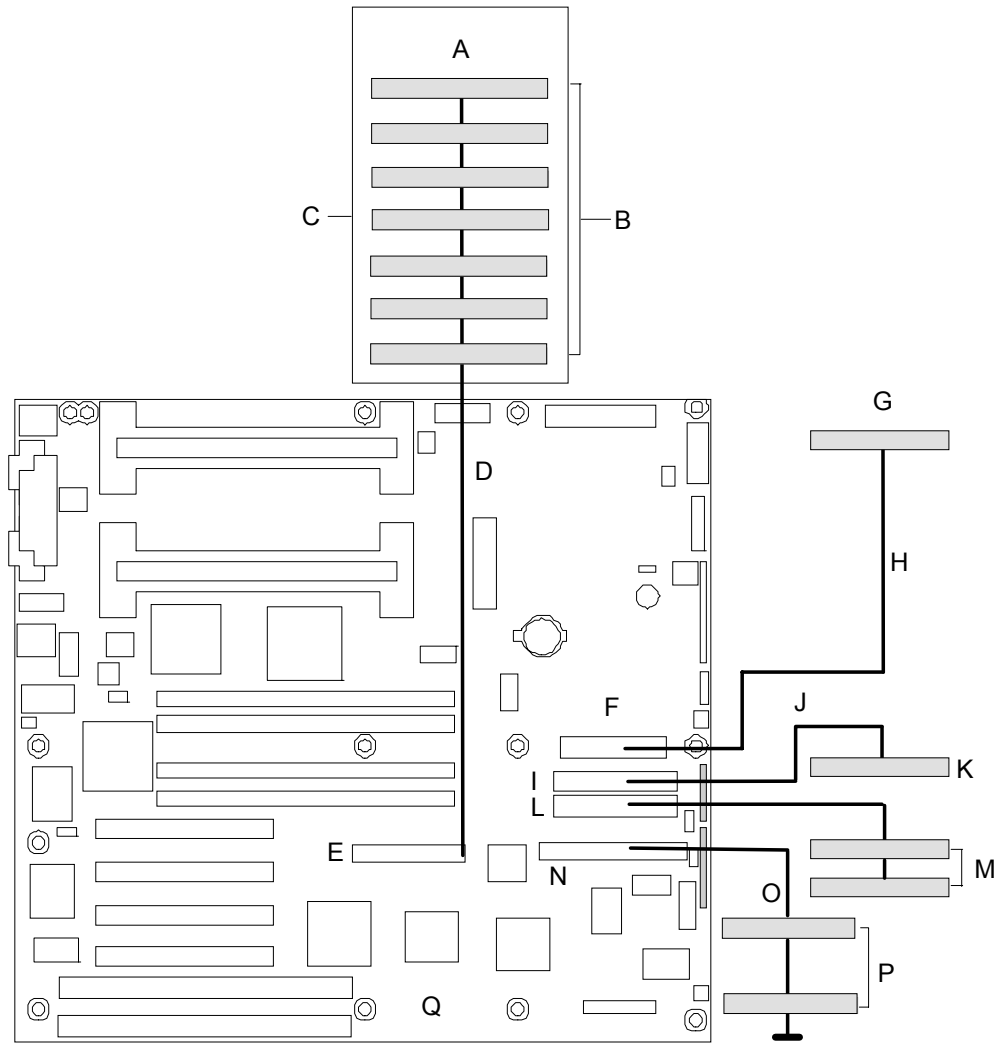

Standard System Cable Configuration

- A— Seven SCSI disk drive bays
- B— SCSI Hard disk drives
- C— SCSI Backplane
- D— Wide SCSI Interface cable
- E— Wide SCSI connector (68 pin)
- F— Diskette drive connector
- G— Diskette drive
- H— Diskette interface cable
- I— Primary IDE connector
- J— IDE Interface Cable
- K— IDE CD-ROM Drive
- L— Secondary IDE connector
- M— Optional IDE removable media devices (cable not supplied)
- N— Narrow SCSI connector
- O— Narrow SCSI interface cable
- P— Optional SCSI removable media devices
- Q— System Board

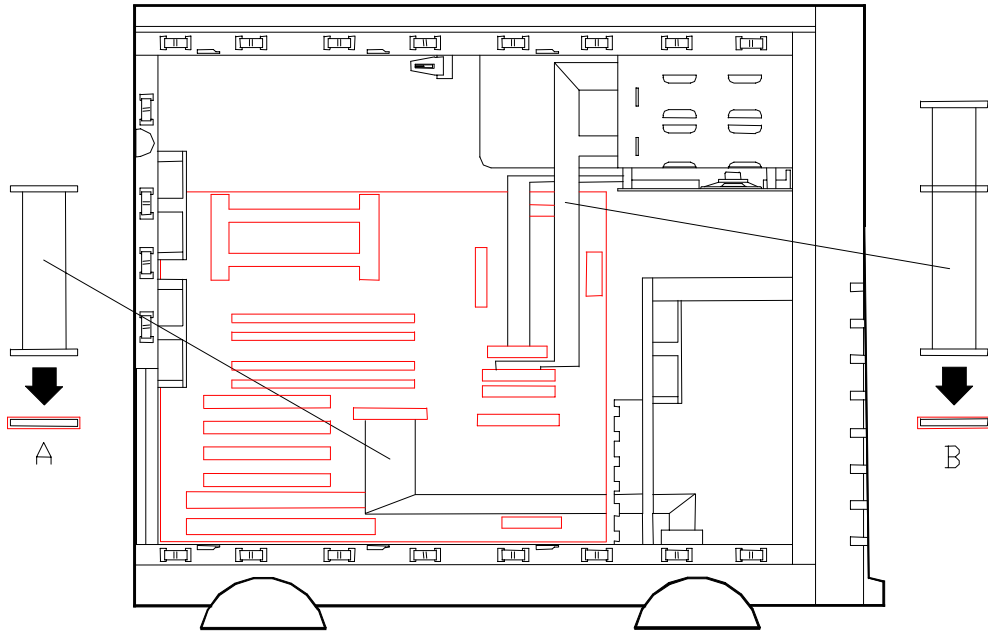

Standard System Cable Routing

- A—Wide SCSI cable (68 pins)
- B—IDE cable (40 pins)

RAID Configuration

The RAID options available for your system are the Mylex AcceleRAID™ 150 and the Mylex AcceleRAID 250 Controller boards, which gives your system the added security of fault tolerance.

If you order a system with a RAID controller, the system is pre-cabled at the factory (see "RAID System Cabling Configuration" figures below.)

If you are adding either the AcceleRAID™ 150 or the AcceleRAID 250 Controller you must install, cable, and configure the controller. Refer to "Installing a RAID Controller Board" in Chapter 4.

 **Note:** Next Boot Status for the first Symbios SYM53C875 controller must be turned **OFF** if you install the optional Mylex AcceleRAID™ 150 or Mylex AcceleRAID 250 Controller board in your system. Refer to "Symbios Configuration Utility" found in Chapter 3.

Note that Jumper JP10 (see figure below) that enables the SCSI Interrupt Steering Logic (SISL) control on the RAID controller must be in its off position (not jumpered), which is its default position.

 **Note:** The jumper is set correctly at the factory for your system configuration. If your system requires a jumper change, change only the jumper setting for that condition. Otherwise, keep the jumper at its factory setting.

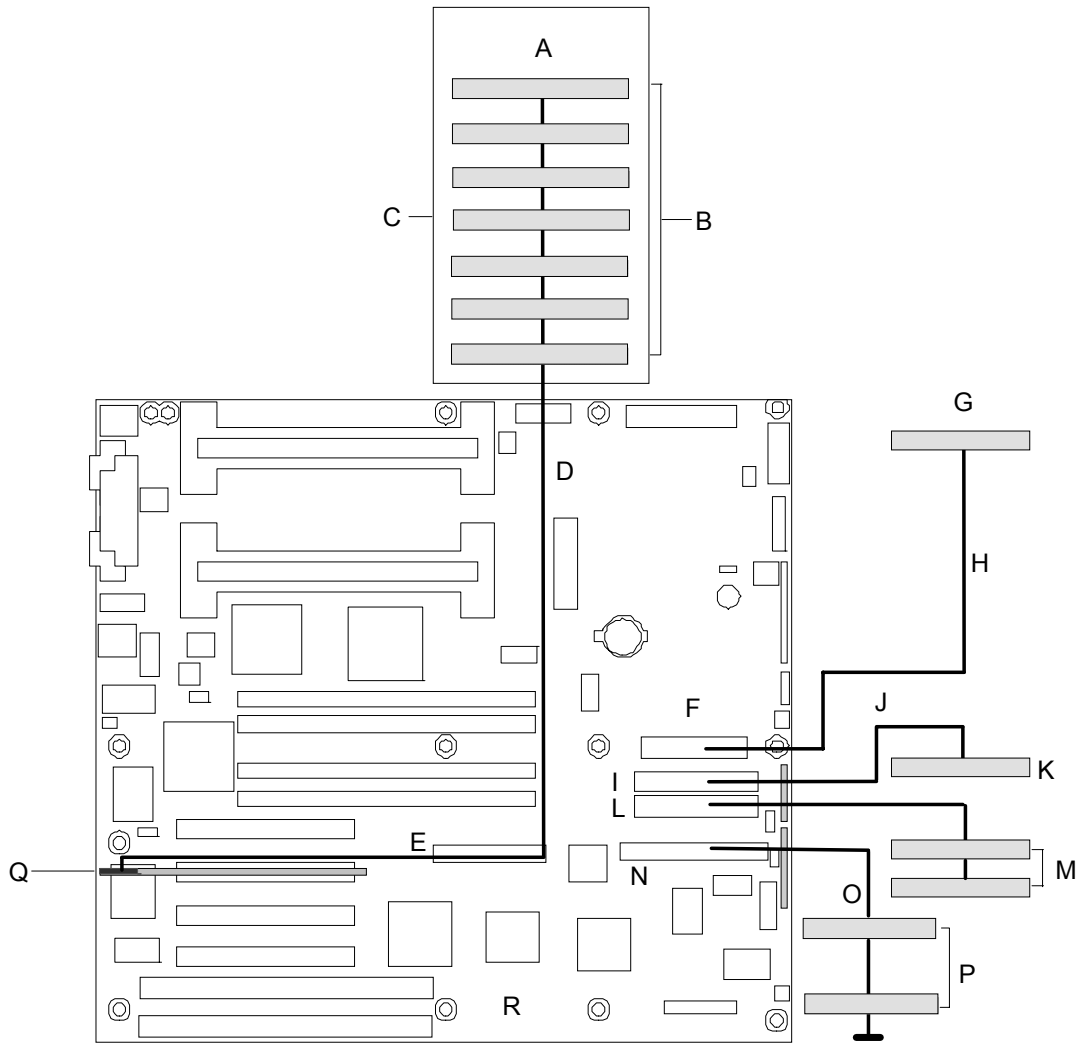

RAID System Cable Configuration

- A— Seven SCSI disk drive bays
- B— SCSI Hard disk drives
- C— SCSI Backplane
- D— Wide SCSI Interface cable
- E— Wide SCSI connector (68 pin)
- F— Diskette drive connector
- G— Diskette drive
- H— Diskette interface cable
- I— Primary IDE connector
- J— IDE Interface Cable
- K— IDE CD-ROM Drive
- L— Secondary IDE connector
- M— Optional IDE removable media devices (cable not supplied)
- N— Narrow SCSI connector
- O— Narrow SCSI interface cable
- P— Optional SCSI removable media devices
- Q— Mylex AccelaRAID Controller
- R— System Board

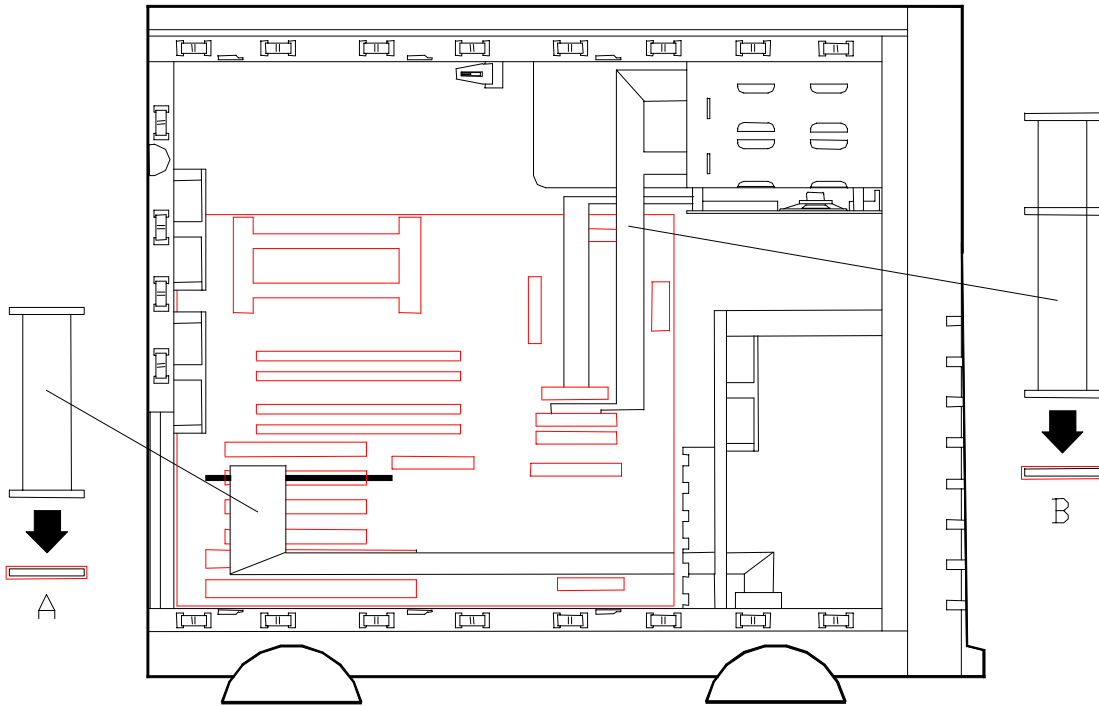

RAID System Cable Routing

- A—Wide SCSI cable (68 pins)
- B—IDE cable (40 pins)

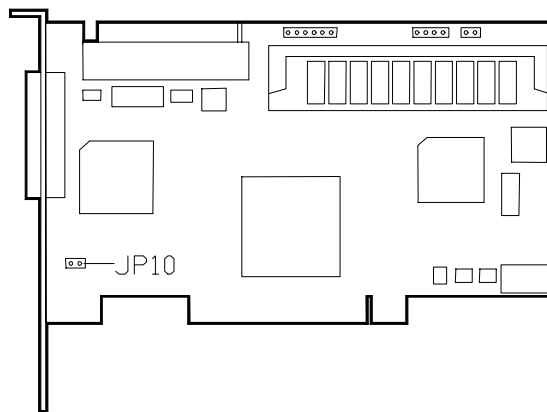

AcceleRAID Jumper JP10

B

System Setup Utility

- System Setup Utility (SSU)
- Creating SSU Diskettes
- Running the SSU
- Exiting the SSU

System Setup Utility (SSU)

The System Setup Utility (SSU) is a DOS-based utility that supports extended system configuration operations for onboard resources and add-in boards. It also allows you to view the system event log and to set system boot and security options. Use the SSU when you need to:

- Add and remove ISA Legacy boards affecting the assignment of resources (ports, memory, IRQs, DMA)
- Change the server configuration resource settings
- Save the server configuration
- View or clear the system event log.

If you install or remove an ISA Legacy add-in board, you must run the SSU to reconfigure the server.

The SSU is PCI-aware, and it complies with the ISA Plug and Play specifications. The SSU works with any compliant configuration (.CFG) or overlay (.OVL) file supplied by the peripheral device manufacturer.

The I/O baseboard includes .CFG and .OVL files. The .CFG file describes the characteristics of the board and the system resources that it requires. The configuration registers on PCI and ISA Plug and Play add-in boards contain the same type of information that is in a .CFG file. Some ISA boards also include a .CFG file.

The SSU uses the information provided by the .OVL and .CFG files, configuration registers, NVRAM, and the information that you enter, to specify a system configuration. The SSU writes the configuration information to NVRAM memory.

The SSU stores configuration values in NVRAM memory. These values take effect when you boot the server. POST checks the values against the actual hardware configuration; if they do not agree, POST generates an error message. You must then run the SSU to specify the correct configuration before the server boots up.

Creating SSU Diskettes

SSU may be run directly from the EXPRESSBUILDER CD-ROM or from DOS-bootable diskettes. Before you can run the SSU from diskettes, you must copy the SSU from the EXPRESSBUILDER CD-ROM to a diskette.

If your diskette drive is disabled, or improperly configured, you must use the FLASH-resident BIOS Setup Utility (F2) to enable it so that you can use the SSU. If necessary, you can disable the drive after you exit the SSU. Information entered using the SSU overrides information entered using Setup.

 **Note:** Because of license restrictions, the SSU diskette, as created by the EXPRESSBUILDER CD-ROM, is not bootable. In order to use this diskette, you must make it bootable.

1. Power on the system.
2. If the diskette drive is disabled, enable it using the BIOS Setup, explained later in this chapter Utility and ensure that it is user accessible. Specify the correct type of diskette drive.
3. Using the EXPRESSBUILDER CD-ROM, create the SSU diskette.

Running the SSU

1. Turn on your video monitor and your system.
2. There are two ways to start the SSU:
 - **After creating an SSU diskette from the CD:** Insert the SSU diskette in drive A, and reboot your server from the diskette.
 - **From diskette after installing your operating system:** Insert the SSU diskette in Drive A. At the MS-DOS prompt, type **a:** and press **Enter** to change to drive A. Type **SSU** and press **Enter**.
3. Follow the system prompts to load the SSU. When the SSU title appears on the screen, press **Enter** to continue.
4. When the main window of the SSU displays, you can customize the user interface before continuing.

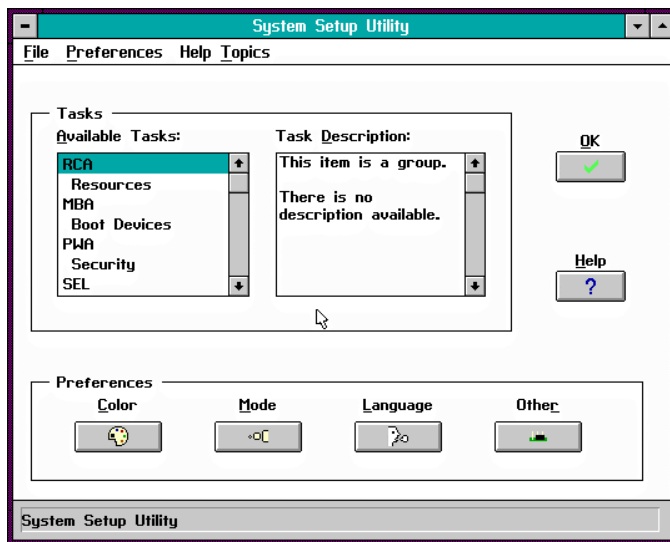

System Setup Utility Main Menu Window

Customizing the SSU

The SSU lets you customize the user interface according to your preferences. The AF sets these preferences and saves them in the AF.INI file so that they take effect the next time you start the SSU. There are three user-customizable settings:

- **Color**—this button lets you change the default colors associated with different items on the screen with predefined color combinations. The color changes are instantaneous.
- **Mode**—this button lets you set the desired expertise level.
 - novice
 - intermediate
 - expert

The expertise level determines which tasks are visible in the Available Tasks section and what actions each task perform. For a new mode setting to take effect, the user must exit the SSU and restart it.

- **Language**—this button lets you change the strings in the SSU to strings of the appropriate language. For a new language setting to take effect, you must exit the SSU and restart it.
- **Other**—this button lets you enable or disable the status bar located at the bottom of the SSU menu displays.

There are three ways to change the interface default values:

- Use the mouse to click on the proper button in the Preferences section of the SSU Main window.
- Use the tab and arrow keys to highlight the desired button, and press the spacebar or **Enter**.
- Access the menu bar with the mouse or hot keys (Alt + underlined letter).

 **Note:** If you run the SSU from non-writable media (EXPRESSBUILDER CD-ROM), customizing preferences will be lost when you exit the SSU.

Launching a Task

It is possible to have many tasks open at the same time, although some tasks may require complete control to avoid possible conflicts. The tasks achieve complete control by keeping the task as the center of operation until the user closes the task window.

There are three ways to launch a task:

- In the SSU Main window, double-click on the task name under Available Tasks to display the main window for the selected task.
- Highlight the task name, and click on OK.
- Use the tab and arrow keys to highlight the task name, and press the spacebar.

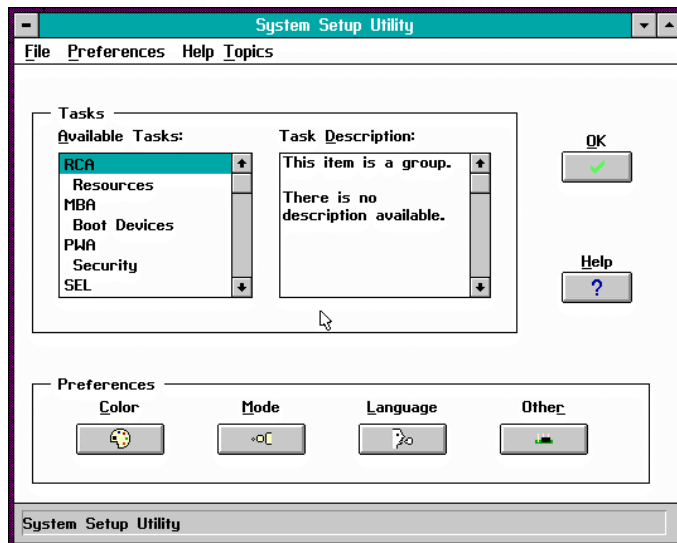

System Setup Utility Main Menu Window

Resource Configuration Add-in (RCA) Window

The RCA provides three major functions:

- Creates representations of devices that cannot be discovered by the system (ISA cards)
- Modifies the contents of the system by adding and removing devices
- Modifies the resources used by devices.

You can use the RCA window to define an ISA card or add an ISA card by clicking on the appropriate button. Removing an ISA card requires that the card be highlighted in the Devices section of the screen before clicking on the button.

1. From the SSU main window, launch the RCA by selecting the “Resources” task under the RCA heading in the task box. Click OK.
2. When the RCA window appears, it displays messages similar to the following:

Baseboard: System Board

PCI Card: Bus 00 dev 09 -- Multifunction Controller

PCI Card: Bus 00 dev 0A -- SCSI Controller

PCI Card: Bus 00 dev 0B -- Ethernet Controller

PCI Card: Bus 00 dev 0C -- VGA Controller

PCI Card: Bus 00 dev 0F -- Multifunction Controller

PCI Card: Bus 00 dev 10 -- Host Processor Bridge

PCI Card: Bus 00 dev 12 -- Host Processor Bridge

PCI Card: Bus 00 dev 13 -- Host Processor Bridge

PCI Card: Bus 00 dev 14 -- Host Processor Bridge

PCI Card: Bus 01 dev 09 -- Interrupt Controller

3. To configure a device, select its name in the Devices section of the RCA window, and press the spacebar or double-click on it.
4. Make configuration changes and click on OK to return to the RCA window. Repeat Steps 3 and 4 to configure additional devices.
5. Save all the changes made by clicking on the Save button. Saving writes your current configuration to nonvolatile storage where it will be available to the system after every reboot.
6. Close the RCA window and return to the Main Menu by clicking on the Close button.

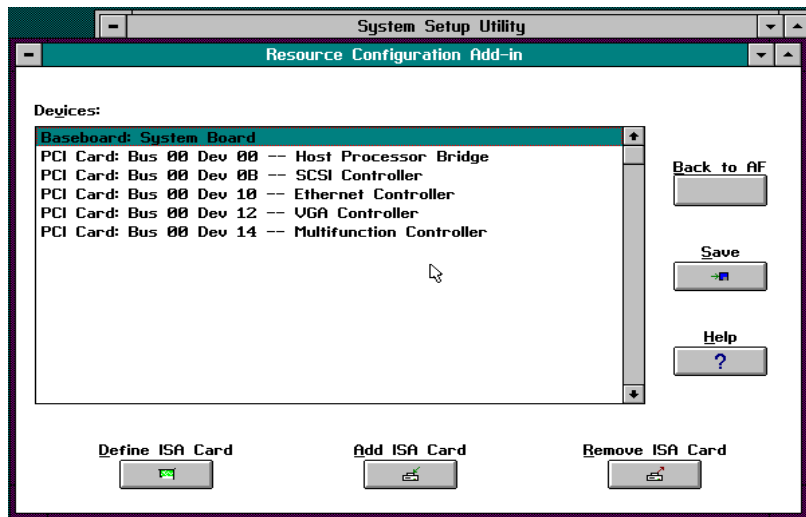

RCA Window

Defining an ISA Card

An ISA card usually comes with a vendor-created .CFG file that specifies the resources the card requires to function properly. If the .CFG file is unavailable, you must manually create it or define the card through the SSU. Defining an ISA card consists of specifying the name of the card and the resources it consumes. This allows the RCA to consider the ISA card resource requirements when the RCA tries to resolve conflicts.

1. From the SSU main window, launch the RCA by selecting the “Resources” task under the RCA heading in the task box.
2. When the RCA window appears, click on the “Define ISA Card” button.
3. To add or remove ISA card resources, click on the appropriate resource buttons, select the desired value, and click on Add or Remove.
4. After you complete the necessary information, click on Save.
5. To edit a card, click on Load to retrieve the card information. After making changes, click on Save.
6. To create a card, click on New Board.
7. To remove a current definition of a card, click on Delete Board.
8. To return to the RCA Menu, click on Close.

Adding and Removing ISA Cards

Adding and removing cards through the RCA provides a way for the RCA to run its conflict detection algorithms on the resources requested by the cards. This alerts you to any possible problems with that particular card in the current configuration.

To add an ISA card:

1. Click on Add ISA Card in the RCA window.
2. Specify the directory for the .CFG file.
3. Select the file and click on Ok.

To remove an ISA card:

1. Select a valid ISA card in the Devices section of the RCA window.
2. Click on Remove ISA Card.

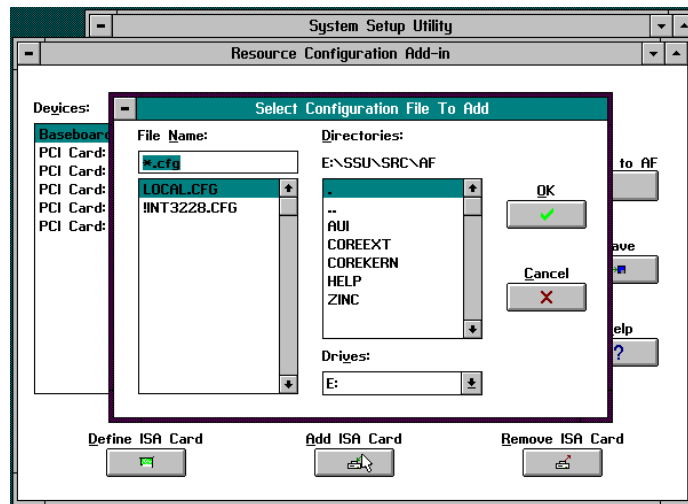

Adding and Removing ISA Cards Window

Modifying Resources

Modifying the resources of a device may be necessary to accommodate certain operating systems, applications, and drivers. It may also be necessary to modify resources to resolve a conflict.

To modify the resources associated with a device:

1. Highlight the device in the Devices section of the RCA window.
2. Press the spacebar or double-click on the entry.

The functions of the selected device along with possible choices and the resources associated with those choices displays.

To make a modification:

1. Highlight the function in the Configuration window.
2. Double-click or press the space bar (this updates the Choice and resource lists).
3. Press the tab key to get to the Choice list, and press **Enter**.
4. Use the arrow keys to select a proper choice, and press **Enter** again.
5. If the choice allows multiple possible values for a particular resource, use the hot key to select a resource, and press the spacebar or double click on the resource.
6. Select the desired resource, and click on Ok.

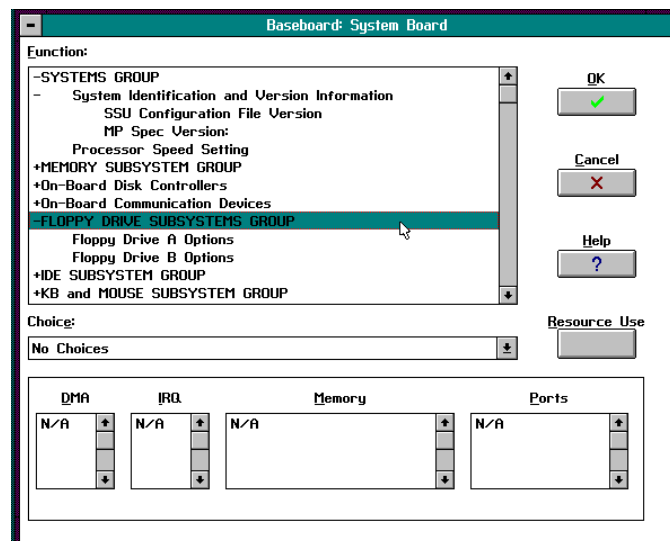

Configuration Window

Recommended Resource Settings

The following table shows the recommended RCA system board settings for a sample system and provides a place for you to record any changes you make to the settings.

| SYSTEM GROUP | NORMAL SETTING | YOUR CONFIGURATION |
|---|-----------------------------------|--------------------|
| System Identification and Version Information | | |
| SSU Configuration File Version | Display Only | |
| MP Spec. Version | V 1.4 | |
| Processor Speed Setting | 3.5 X Bus Speed | |
| MEMORY SUBSYSTEM GROUP | | |
| Extended Memory Options | Use BIOS Setup Utility | |
| ON-BOARD DISK CONTROLLER GROUP | | |
| On-board Floppy Controller | Enable | |
| On-board IDE Controller | Enable Primary and Secondary | |
| ON-BOARD COMMUNICATIONS DEVICE GROUP | | |
| Serial Port 1 Configuration | 3F8h – IRQ4 | |
| Serial Port 2 Configuration | 2F8h – IRQ3 | |
| Parallel Port Configuration | 378h – IRQ7 | |
| Parallel Port Mode | Extended Capabilities, Port DMA 1 | |
| FLOPPY DRIVES GROUP | | |
| Floppy Drive A Option | 3.5 1.44/1.25 MB Drive | |
| Floppy Drive B Option | Disabled or not installed | |
| IDE DEVICES GROUP | | |
| IDE 32-Bit I/O | Enable | |
| KEYBOARD GROUP | | |
| Numlock | OFF | |
| Key Click | Disable | |
| Typematic Speed | 30CPS | |
| Typematic Delay | 500 MS Delay | |
| SCSI ROM BIOS GROUP | | |
| Embedded SCSI Devices Option ROM Scan | Enable | |

System Resource Usage

Clicking on the Resource Use button in the Configuration window displays the System Resource Usage window. This window shows what resources each device is consuming. This information is useful for choosing resources if a conflict occurs. Devices can be organized according to the resources the user wants to examine using the options in the Resource section of the screen.

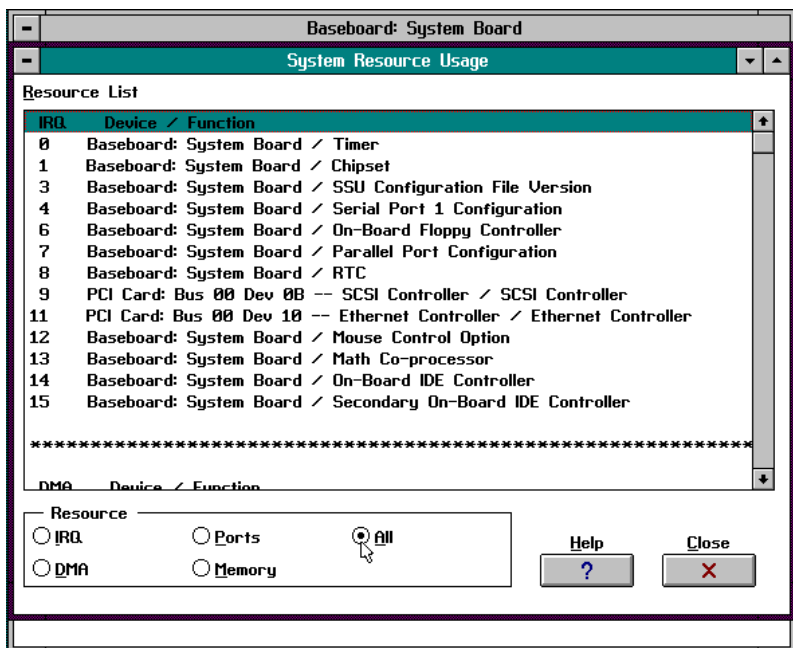

System Resource Usage Window

Multiboot Add-in (MBA) Window

The MBA lets you set the system boot priority. The boot priority is the order the BIOS uses to boot the operating system from various devices in your system.

To set the boot priority of your system:

1. From the SSU Main Menu, launch the MBA by selecting the “Boot Devices” task under the MBA heading in the task box. Click OK.
2. When the MBA window displays, the “Boot Device Priority” window lists the current boot priority order. The “Hard Drives” window lists the hard disk drive(s) in your system. During bootup, BIOS searches the list of device types shown in the “Boot Device Priority” list, starting with the first device on the list. When BIOS gets to the Hard Drives, the BIOS tries each device shown in the “Hard Drives” list, starting at the top of the list.
3. To change the priority of an entry in either list, select the entry and click on the “Move UP” or “Move Down” buttons.
4. Click on the Save button to save the boot priority.
5. Click on the Close button to return to the Main Menu.

Password Administration (PWA) Window

The PWA configures administrator and user passwords and other security options.

1. From the SSU Main Menu, launch the PWA by selecting the “Security” task under the PWA heading in the task box. Click OK. The Security window displays.
2. Select the Administrator and User Password buttons to change passwords.
3. Select the Options button to enable or disable security options. For an explanation of the configurable security options, press the Help button.
4. Click on the Save button to save the security option changes.
5. Click on the Close button to return to the Security menu.
6. Click on the Close button to return to the Main menu.

System Event Log (SEL) Window

The SEL displays information on the events stored in the system log area. The information stored includes the name of the event, the date and time the event occurred and data pertinent to the event. Event data may include POST error codes that reflect hardware errors or software conflicts within the system.

 **Note:** Refer to Chapter 5, “Problem Solving” for definitions on all POST error codes

1. From the SSU Main Menu, launch the SEL by selecting the “SEL Viewer Add-in” task under the SEL heading in the task box. Click OK. The SEL Viewer Add-in window (Event Log) displays.
2. The following screen choices are available:

| Screen Choice | Description |
|---------------|---|
| File Menu | Loads, saves and clears the Event Log data. The Event Log data file is saved in either text or binary format depending on the output format selected under the Settings menu. Selecting Exit returns you to the SSU Main Menu. |
| View Menu | Views all events, events by sensor type, or events by event type. The Event Log data file is viewed in either text or binary format depending on the display format selected under the Settings menu. |
| Settings menu | Events are displayed and saved either in Hex codes (binary format) or as text. Select “Display Hex” to view Hex or “Display Verbose” to view text. Select “Output Binary” to save log data in Hex or “Output Text” to save log as text. Note: Only files saved in binary format can be viewed using the SSU SEL utility. |

Exiting the SSU

Exiting the SSU causes all windows to close.

1. Exit the SSU by opening the menu bar item File in the SSU Main window.
2. Click on Exit or Highlight Exit, and press **Enter**.

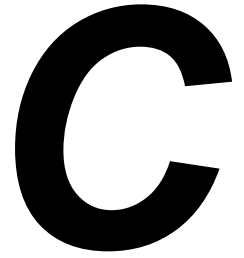

Emergency Management Port

- Emergency Management Port
- How the EMP Works
- EMP Requirements and Configurations
- Setting Up the Server for the EMP
- Main EMP Window
- Phonebook
- Management Plug-ins

Emergency Management Port

The Emergency Management Port (EMP) allows remote server management via a modem or direct connection. The COM2 port on your server provides an interface to Console Manager software located in a second system.

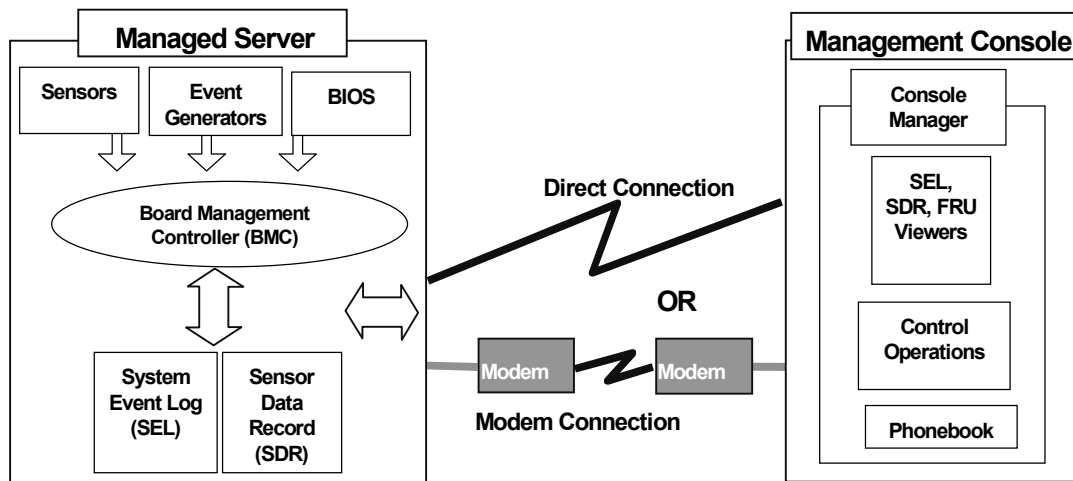

Emergency Management Port Configuration

The following server operations are available from the Console Manager:

- Connecting to remote servers
- Powering the server ON or OFF
- Resetting the server
- SEL viewer
- SDR viewer
- FRU viewer

The Console Manager has a Phonebook, which you use to connect to a selected server.

Referring to the above figure, the Board Management Controller (BMC) in your server monitors system management events and logs their occurrence in the System Event Log (SEL). These include events such as over-temperature and over-voltage conditions, fan failure, or chassis intrusion. To enable accurate monitoring of temperature, voltage, etc. independent of an event, the BMC also maintains Sensor Data Record for each sensor (SDR), from which sensor information can be retrieved.

How the EMP Works

The EMP shares use of the COM 2 port with your system. When the EMP has control of the port, the port operates in command state. When the system has control of it, the port operates in redirect state. When connecting to a server, the EMP checks to determine the current COM 2 port state. The following discussion covers how the EMP functions in each state:

- *Command state* is the default COM 2 state. In this state, the EMP communicates with the server, allowing the client to remotely reset or power the server up or down. The client can also view the server's System Event Log (SEL), Field Replaceable Unit (FRU) information, or Sensor Data Record (SDR) table.
- In *redirect state*, the EMP serves as a PC ANSI terminal window for BIOS console redirection. Commands typed in this terminal window are transmitted through BIOS to the server's console, and text displayed on the server console are displayed on the EMP's terminal window. With the EMP in this state, you can remotely view boot messages, access BIOS setup, and run DOS text mode applications through the EMP's terminal window.

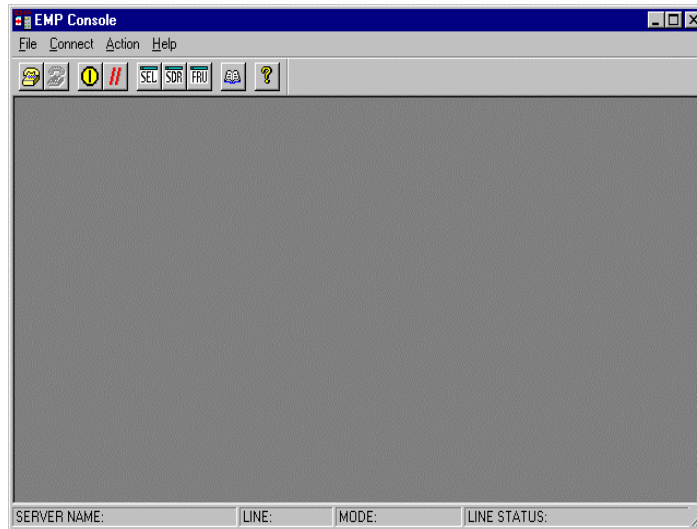

EMP in Command State

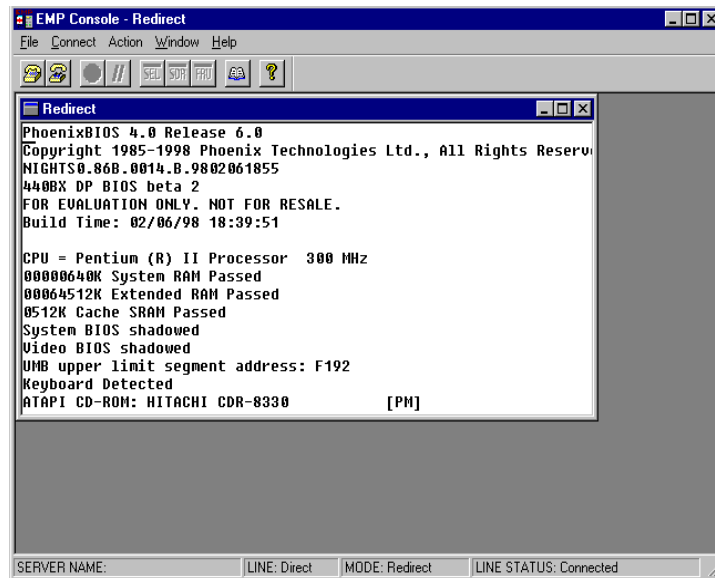

Console in Redirect State

The above figure shows the EMP window in redirect state with the terminal window. The text that appears on the server monitor displays in the redirect window.

Availability of the various EMP features is determined by two things: the EMP access mode selected during configuration in the System Management Submenu of the BIOS Server Menu, and if the server's COM 2 port is configured for console redirect in BIOS. The three EMP access modes are disabled, pre-boot, and always active.

EMP Access Modes (Server Configured for Console Redirect)

| Mode | Server is powered off | During POST | After OS boots |
|---------------|---------------------------------------|------------------|--------------------------|
| Disabled | Redirect window appears, but is blank | Redirect window | Redirect window |
| Pre-boot | EMP commands available | Redirect window* | Inactive redirect window |
| Always Active | EMP commands available | Redirect window* | EMP commands available |

*The operation mode can be modified by selections in the post reset and post-power-up dialogs. These are server control dialogs available with the EMP.

EMP Access Modes (Server not Configured for Console Redirect)

| Mode | Server is powered off | During POST | After OS boots |
|---------------|---------------------------------------|---------------------------------------|---------------------------------------|
| Disabled | Redirect window appears, but is blank | Redirect window appears, but is blank | Redirect window appears, but is blank |
| Pre-boot | EMP commands available | EMP commands available | Redirect window appears, but is blank |
| Always Active | EMP commands available | EMP commands available | EMP commands available |

EMP Requirements and Configurations

This section outlines the requirements and configurations necessary for using the EMP.

Operating Systems:

- Windows 95
 - 16 MB of RAM, 32 MB recommended
 - 20 MB disk space
- Windows NT
 - Windows NT 4.0 or later
 - 24 MB of RAM, 32 MB recommended
 - 20 MB disk space

Client Configuration: The EMP will support all COM ports on the client system, along with any Windows NT/95 compatible modem.

Server Configuration: The EMP requires the server's COM 2 port to be connected to an external modem or directly connected to a serial cable.

Direct Connect Configuration: A null modem serial cable is needed. Connect one end of the cable into the COM 2 port of server and the other into a port on the client machine.

Modem Configuration: On the client, the EMP uses the Windows Application Program Interface (API) to determine if a modem is connected and available. The EMP does not configure the modem; it should be preconfigured through Windows.

For modem support, the server must use a Hayes compatible 14400 bps modem. The modem must be on the NT Hardware Compatibility List provided by Microsoft. The server modem must be set in auto-answer mode for the EMP to be able to connect to it.

Setting Up the Server for the EMP

To use the EMP, you must configure the server's BIOS with specific settings. These settings take place in two submenus of the BIOS Server menu, the System Management Submenu and the Console Redirect Submenu. The earlier BIOS settings section shows all available options. This section focuses on those settings that must be configured to use the EMP.

System Management Submenu

All EMP related settings occur from the System Management Submenu of the Server main menu. Change only the items below; all other default settings should remain the same.

EMP Password: Anytime you attempt to initiate a connection, a prompt for the user password appears. If you never set up the EMP password, anyone can access the EMP by clicking OK through the password prompt.

In the EMP Password area of the System Management Submenu, type in a password of up to 8 alphanumeric characters. If a beep is heard, the password was not accepted and a different password must be entered.

EMP Access Modes: Choose either Disabled, Pre-boot, or Always Active, depending on the type of EMP access needed. The tables above show what is available with a given setting.

EMP Restricted Mode Access: Set Restricted Mode to either enabled or disabled as needed. If in enabled mode, this means that the EMP's server control options, Power On/Off and Reset, are unavailable. In disabled mode, these same server control options are available.

EMP Direct Connect/Modem Mode: Select Direct Connect if a null modem serial cable directly connects the server's COM 2 port to the EMP client machine. If they are connected via a modem, select Modem Mode.

Console Redirection Submenu

These settings in the Console Redirection Submenu of the Server menu must be set exactly as noted to be able to use the EMP.

COM Port Address: Select 2F8. This is the COM 2 port that must be used by the EMP. The IRQ# setting automatically populates with the correct number based on the COM Port Address choice.

Baud Rate: Select appropriate speed.

Console Type: Choose PC ANSI.

Flow Control: Choose CTS/RTS + CD.

Main EMP Window

The main EMP window provides a graphical user interface (GUI) to access server control operations and to launch the management plug-ins from. At the top of the GUI is the menu and tool bar. These provide the options to initiate plug-ins and other support features. A status bar at the bottom displays connection information like server name, line status, and mode.

Toolbar

The tool bar buttons of the EMP main window combine server control and management plug-in options available from the Connect and Action menus as follows:



Generates the Connect dialog to allow connection to a selected server.



Disconnects from the server currently connected to.



Generates the Power On/Off dialog.



Generates the Reset dialog.



Launches the SEL viewer.



Launches the SDR viewer.



Launches the FRU viewer.



Opens the phonebook.



Opens the online help.

Status Bar

The status bar displays at the bottom of the current window. It contains the following status information:

- **SERVER NAME**: the name of the server (stored in the Phonebook).
- **LINE**: the type of line connection. This would be either direct or modem.
- **MODE**: either Redirect of EMP, depending on whether the EMP has control of the COM 2 port.
- **LINE STATUS**: gives status information on the server connection. For example, if a server is connected, the status bar says "Connected." Otherwise, the line is blank.

EMP Main Menu

- **File**
 - **Exit** - Exits the EMP.
- **Connect**
 - **Disconnect** - disconnects the server connection.
 - **[Re]Connect** - raises the connect dialog.
 - A list of the five most recent connections - can click on one of the five servers most recently connected to. A connection to the selected server is initiated.
- **Action**
 - **Power On/Off** - powers the server on or off with post-power-up options.
 - **Reset** - resets the server with post-reset options.
 - **SEL Viewer** - opens the SEL viewer.
 - **SDR Viewer** - opens the SDR viewer.
 - **FRU Viewer** - opens the FRU viewer.
 - **Phonebook** - opens the phonebook dialog.
- **Help** - provides version information and help topics for the EMP.

Server Control Operations

Three server control operations are available from the menu or toolbar of the main EMP window, remote server connection, powering the server on and off, and resetting the server. The server console mode can also be switched between EMP active and BIOS redirect modes through post-power-up and reset options.

Connect

When you select [Re]Connect from the Connect menu, the Connect dialog allows you to connect to a selected server. If the client machine is already connected to a server, initiating connection generates a warning message. It lets you know that the existing connection will be terminated if you continue trying to initiate the new connection. You are prompted to enter the EMP password whenever a connection is attempted.

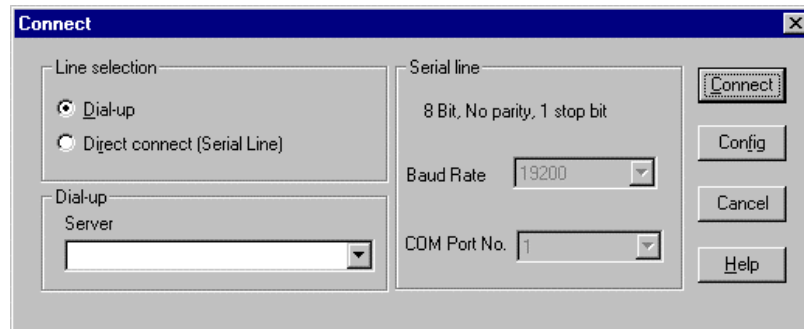

Connect Dialog

Options available in the dialog are:

- **Line Selection** - you can specify whether to use a direct connection or dial-up modem connection to the server.
 - **Dial-up** - connects to a selected server with a modem.
 - **Direct connect (Serial Line)** - connects to the selected server directly using a null modem serial cable.
- **Server** - you can select or enter a server name from a dropdown edit list box of available servers. A server must be selected when the line selection is Dial-up.

-
- **Serial Line** - must be filled out when the line selection is set to Direct connect (Serial Line).
 - **Baud Rate** - must be 19200 for EMP to connect properly.
 - **COM Port No.** - set the COM Port number to which the null modem serial cable is connected.
 - **Connect** - initiates connection to the connected server. When this button is clicked, you are prompted for the EMP password.
 - **Config** - displays the Phonebook dialog.
 - **Cancel** - exits the Connect dialog without any action taken.
 - **Help** - displays dialog level help information.

Power On/Off

Selecting Power On/Off from the Action menu allows you to power the server on or off, with post-power-up options. It generates the Power on/off dialog.

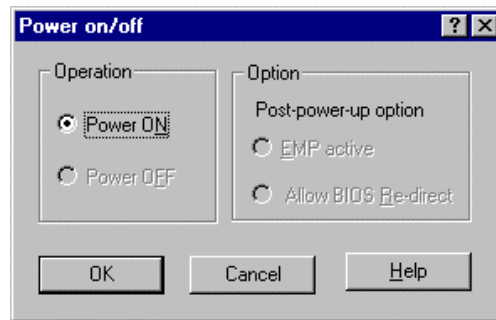

Power On/Off Dialog

Options available in the dialog are:

- **Power ON** - powers on the server.
- **Power OFF** - powers off the server. This option is not allowed if the server is configured in RESTRICTED mode for EMP operations.
- **Post-power-up option** - sets the mode selection of the server to EMP active or BIOS redirection. The setting is available after the next power-up. The default selection is EMP active.
- **Cancel** - exits the dialog without any action taken.
- **Help** - displays dialog level help information.

Reset

Selecting Reset from the Action menu generates the Reset dialog so that you can remotely reset the server with post-reset options.

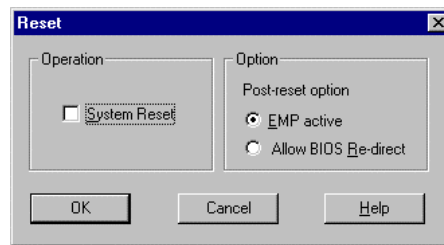

Reset Dialog

Options available in the dialog are:

- **System Reset** - resets the server with the selected post-reset options. This operation is not allowed if the server is configured in RESTRICTED mode for EMP operations.
- **Option Group** - sets the post-reset option that will be effective after reset. The options are EMP active or BIOS redirection. The default selection is EMP active.
- **Cancel** - exits the dialog without any action taken.
- **Help** - displays dialog level help information.

Phonebook

The EMP provides a support plug-in known as the Phonebook. The Phonebook stores names and numbers of servers in a list that can be updated by adding, modifying or deleting entries. The Phonebook can be opened from the main menu and tool bars, or launched from the Connect dialog by clicking the Config button.

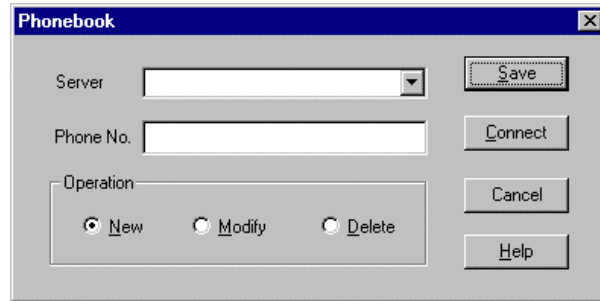

Phonebook Dialog

Options available in the dialog are:

- **Server** - a dropdown list of server names previously stored in the Phonebook. If the New radio button is selected in the Operation area, this area is cleared.
- **Phone No.** - the number of the selected server. If the New radio button is selected in the Operation area, this area is cleared.
- **Operation**
 - **New** - lets you make a new entry in the phonebook. Selecting this option clears the Server and Phone No. Fields. You must click Save for the entry to be added to the phonebook.
 - **Modify** - lets you edit an existing entry. You select an existing entry from the Server dropdown edit box and modifies the existing phone number before selecting this option. Click Save in order to store this entry in the phonebook.
 - **Delete** - lets you delete an entry from the phonebook. You must first select an existing server from the Server dropdown edit box before selecting this option. You must click Save for the entry to be deleted.
- **Save** - saves a new or modified Phonebook entry or deletes an entry if the Delete radio button was selected.
- **Connect** - raises the Connect dialog with the server from the Phonebook's Server dropdown edit box already populating the Connect dialog's Server dropdown edit box.
- **Cancel** - exits the dialog without any action taken.
- **Help** - displays dialog level help information.

Management Plug-ins

SEL Viewer

The SEL viewer provides access to the System Event Log on the server and can display records in either hexadecimal or text (verbose) form. Options available through the SEL viewer (see the SEL Viewer figure below) are:

- View the SEL from a file
- Save the SEL to a file
- View SEL summary info
- View all SEL entries
- View SEL info by event type
- View SEL info by sensor type
- Set SEL display mode to either Hex or verbose mode
- Set the SEL output file format to either text or binary format
- Close the SEL viewer
- Exit the EMP

| Rec. ID | Event Type | Time Stamp | Generator ID | Emv Rev | Se |
|---------|--------------|---------------------|---------------------|---------|----|
| 0x0005 | System Event | 04/19/08 - 15:52:20 | BIOS | #02 | Sy |
| 0xC005 | System Event | Fre-Init timestamp | Primary HSC - LU... | #02 | Dr |
| 0xD005 | System Event | Fre-Init timestamp | BMC - LUN #0 | #02 | PH |
| 0xE005 | System Event | Fre-Init timestamp | BMC - LUN #0 | #02 | Fa |
| 0xF005 | System Event | 04/19/08 - 15:55:42 | BIOS | #02 | Sy |
| 0x0006 | System Event | Fre-Init timestamp | BMC - LUN #0 | #02 | PH |
| 0x1006 | System Event | Fre-Init timestamp | BMC - LUN #0 | #02 | Fa |
| 0x2006 | System Event | Fre-Init timestamp | Primary HSC - LU... | #02 | Dr |
| 0x3006 | System Event | 04/19/08 - 15:57:28 | BIOS | #02 | Sy |
| 0x4006 | System Event | 04/23/08 - 09:35:42 | BMC - LUN #0 | #02 | Se |
| 0x5006 | System Event | Fre-Init timestamp | BMC - LUN #0 | #02 | PH |
| 0x6006 | System Event | Fre-Init timestamp | BMC - LUN #0 | #02 | Fa |
| 0x7006 | System Event | Fre-Init timestamp | Primary HSC - LU... | #02 | Dr |
| 0x8006 | System Event | 04/23/08 - 09:38:39 | BIOS | #02 | Sy |
| 0x9006 | System Event | 04/23/08 - 09:38:39 | BMC - LUN #0 | #02 | Pc |
| 0xA006 | System Event | 04/23/08 - 09:38:39 | BMC - LUN #0 | #02 | Pc |

SERVER NAME: LINE: Direct MODE: EMP LIN

SEL Viewer

SEL Viewer Menu Options

The following menu options are found on the SEL viewer menu bar:

■ File

- **Open** - you can view SEL data from a previously saved file if it was stored in binary format. Selecting the Open menu item allows you to specify a filename under which the data is found. The default filename is "SELLOG.DAT." If the file cannot be opened, the program displays an error message.
- **Close** - you can close the SEL viewer.
- **Save As** - dumps the SEL data to a file in either binary raw or verbose text format. The binary file may be retrieved later. Selecting this option lets you specify a filename to which the data would be saved. The default filename is "SELLOG.DAT." If there is no data, an error message will be displayed.
- **Exit** - exits the EMP.

■ Connect

■ View

- **SEL Information** - displays SEL summary information as returned by the server.
 - **All Events** - displays all events in the SEL.
 - **By Sensor Type** - shows all events in the SEL generated by a specific sensor type such as voltage, temperature, etc.
 - **By Event** - displays all the events in the SEL of a particular type; for example, by memory or threshold. A pop-up menu lets you select the event type to display. This pop-up menu displays all the event types that may be generated by the particular hardware.
- ### ■ Settings
- you can change several operating parameters for the SEL viewer. This menu displays the following suboptions:
- **Display HEX/Verbose** - toggles between HEX mode and interpreted mode of displaying SEL records.
 - **Output Text/Binary** - determines whether SEL data will be saved to the file in binary format or verbose format.
- ### ■ Window
- gives options for displaying currently open windows.
- ### ■ Help
- provides version information for the SEL viewer and provides help topics on the EMP.

Sensor Type Codes

The Sensor Type Code Table provides information regarding:

- The type of sensor generating the SEL entry
- The name of the sensor
- The microcontroller which initiated the SEL entry
- The warning or error which initiated the SEL entry.

Using the Sensor Type Code Table

Compare the *Sensor Type and Number* message shown in the SEL viewer display (above) to the Sensor Type/Number in Verbose column in the table below. Using information in the *Sensor Name* column in the table you can determine the physical component which generated the SEL message. The *Generator ID* column in the table identifies the microcontroller which reported the event to the SEL. Detailed information regarding the event is available from the *Event Description* column in the SEL Viewer.

For example, if there is a Fan #10 entry in the *Sensor Type and Number* column of the SEL Viewer, by looking at the Sensor type Codes table you can determine that the Baseboard Fan 1 caused this entry. The entry was reported through the Baseboard Management Controller (BMC) on the system board.

Sensor Type Codes

| Sensor Type and Number in Verbose | Sensor Name | Generator ID |
|-----------------------------------|----------------------|--------------|
| Reserved | 00h | BMC |
| Temperature #17 | Processor1 Temp | BMC |
| Temperature #18 | Processor2 Temp* | BMC |
| Temperature #19 | Baseboard Temp1 | BMC |
| Temperature #1A | Baseboard Temp2 | BMC |
| Voltage # 01 | Baseboard 5V | BMC |
| Voltage # 02 | Baseboard 3.3V | BMC |
| Voltage # 03 | Primary Processor | BMC |
| Voltage # 04 | Secondary Processor* | BMC |
| Voltage # 05 | Processor 2.5V | BMC |

*Not applicable to all servers

Sensor Type Codes (continued)

| Sensor Type and Number in Verbose | Sensor Name | Generator ID |
|-----------------------------------|---|--------------|
| Voltage # 06 | 5V Standby | BMC |
| Voltage # 07 | Baseboard SCSI-A Term1 | BMC |
| Voltage # 08 | Baseboard SCSI-A Term2 | BMC |
| Voltage # 09 | Baseboard SCSI-A Term3 | BMC |
| Voltage # 0A | Baseboard –12V | BMC |
| Voltage # 0B | Baseboard SCSI-B Term1 | BMC |
| Voltage # 0C | Processor 1.5V | BMC |
| Voltage # 0D | Baseboard –5V | BMC |
| Voltage # 0E | Baseboard 12 | BMC |
| Fan # 0F | Baseboard Fan0 | BMC |
| Physical Security #26 | Chassis Intrusion | BMC |
| Secure Mode Violation Attempt #27 | EMP password (at the time of connecting to the server) | BMC |
| Secure Mode Violation Attempt #28 | Secure Mode Violation (while the system is in Secure Mode) | BMC |
| Processor #1B | Processor1 Status | BMC |
| Processor #1C | Processor2 Status* | BMC |
| Memory # 1F | DIMM1 Presence | BMC |
| Memory #20 | DIMM2 Presence | BMC |
| Memory #21 | DIMM3 Presence | BMC |
| Memory #22 | DIMM4 Presence* | BMC |
| Post Error #25 | Refer to <i>Problem Solving – Post Error Codes and Messages</i> | BIOS |
| Watchdog #25 | Watchdog Event | BMC |
| System Event #EF | See the System Event Logging Format Table | BIOS |

*Not applicable to all servers

System Event Logging Format Table

| Sensor Type and Number in verbose | Sensor Type and Number in hex | Event Description in hex | Event type | Event Description |
|--|--------------------------------------|---------------------------------|-------------------------|--------------------------|
| System Event #EF | 12 EF | E7 01 -- -- | System Boot Event | System Boot Event ... |
| System Event #EF | 12 EF | E7 00 -- -- | System Recognition | System Boot Event ... |
| Memory #EF | OC EF | E7 20 -- -- | Single Bit Memory Error | Correctable ECC ... |
| Memory #EF | OC EF | E7 21 -- -- | Double Bit memory Error | Non-Correctable ECC ... |
| Memory #EF | OC EF | E7 02 -- -- | Memory Parity error | Parity ... |
| Critical Interrupt #EF | 13 EF | E7 00 -- -- | Bus Timeout | Bus timeout ... |
| Critical Interrupt #EF | 13 EF | E7 02 -- -- | I/O Check | I/O Channel check NMI |
| Critical Interrupt #EF | 13 EF | E7 03 -- -- | Software NMI | Software NMI |
| Critical Interrupt #EF | 13 EF | E7 04 -- -- | PCI PERR | PCI PERR ... |
| Critical Interrupt #EF | 13 EF | E7 05 -- -- | PCI SERR | PCI SERR ... |

SDR Viewer

The SDR viewer lets you view the Sensor Data Records retrieved from the SDR repository. Options available through the SDR viewer are:

- View all SDR records
- View SDR entries by SDR type
- View SDR summary info
- Set SDR display mode to either Hex or verbose mode
- Close the SDR viewer
- Exit the EMP

SDR Viewer Menu Options

The following menu options are found on the SDR viewer menu bar:

- **File**

- **Close** - closes the SDR viewer.

- **Exit** - exits the EMP.

- **View**

- **Display all Records** - displays all records from the SDR repository.

- **SDR Type** - displays the records of a particular SDR type. You select an SDR type from a pop-up menu that displays all the SDR types available for the given hardware.

- **SDR Info** - displays the SDR summary information as returned by the server.

- **Settings** - lets you change operating parameters for the SDR viewer. This menu displays the following suboption:

- **Display HEX/Verbose** - toggles between HEX mode and interpreted mode of displaying SDR records.

- **Window** - gives options for displaying currently open windows.

- **Help** - provides version information for the SDR viewer and provides help topics on the EMP.

FRU Viewer

The FRU viewer allows you to view the server's FRU (Field Replaceable Units) data from the server's baseboard FRU information area. Options available with the SDR viewer are:

- View all FRU records

- View FRU summary info

- Set FRU display mode to either Hex or verbose mode

- Close the FRU viewer

- Exit the EMP

FRU Viewer Menu Options

The following menu options are found on the FRU viewer menu bar:

- **File**

- **Close** - closes the FRU viewer.

- **Exit** - exits the EMP.

- **View**

- **Display all Records** - displays all FRU data, which consists of chassis, board, and product information.

- **FRU Info** - displays the FRU summary information as returned by the server.

- **Settings** - lets you change operating parameters for the FRU viewer. This menu displays the following suboption:

- **Display HEX/Verbose** - toggles between HEX mode and interpreted mode of displaying FRU records.

- **Window** - gives options for displaying currently open windows.

- **Help** - provides version information for the FRU viewer and provides help topics on the EMP.

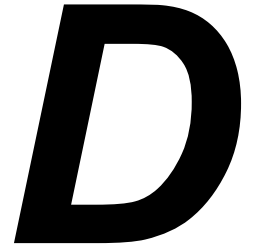

System Status Hardware Support Information

System Status Hardware Support Information

This appendix helps you identify and find a system status hardware item indicated by one of several software monitoring components.

The software monitoring components as they are related to the hardware system status items are listed in the following table:

Software Monitoring Components/Hardware System Status Items

| Software Monitoring Component | Hardware System Status Item |
|-------------------------------|--|
| ESMPRO Server Management | View status based on polling the machine |
| EMP / SSU | View status in the hardware system event log |

Not all items can be monitored with every software component. Monitoring capability relates to how the software component interacts with system hardware. ESMPRO interacts with all hardware components and EMP/SSU interacts with Baseboard hardware. In this system, the SCSI Accessed Fault-Tolerant Enclosure (SAF-TE) interface board is connected to the SCSI backplane. (See Figure "System Chassis (Right Side View)" under "System Overview" in Chapter 1 of this guide.)

The "Monitor Matrix" table below shows which component relates to selected status items. This table also relates the terminology used by the software component to the system hardware.

Monitor Matrix

| Item | ESM PRO | EMP / SSU | Item Location | Board Marking |
|--|------------------------------|-----------|----------------|---------------|
| Chassis front fan | As Item | BB Fan1 | BB-J5J1 | Fan1 |
| Chassis upper rear fan | As Item | CPU Fan2 | BB-J8F1 | FanSink2 |
| Chassis lower rear fan | As Item | CPU Fan1 | BB-J6E1 | FanSink1 |
| Internal disk fan – upper | Internal upper disk (SAF-TE) | N/A | SCSI-BP | J2 |
| Internal disk fan – middle | Middle | N/A | SCSI-BP | J1 |
| Internal disk fan – lower | Lower | N/A | SCSI-BP | J3 |
| Intrusion switch - front | Chassis cover | N/A | SCSI-BP | J6 |
| Intrusion/Interlock switch - left side (front view) | Chassis cover (SAF-TE) | N/A | SCSI-BP | J5 pins 1, 2 |
| Intrusion/Interlock switch - right side (front view) | N/A | N/A | SCSI-BP | J5 pins 3, 4 |
| (1)Power Supply fan | (1) Power (SAF-TE) | N/A | P. S. (Bottom) | N/A |
| (2)Power Supply fan | (2) Power (SAF-TE) | N/A | P.S. (Top) | N/A |

BB = Baseboard
SCSI-BP = SCSI Backplane

Glossary

A

AC

(Alternating Current) The type of current available in wall outlets. All computers must convert alternating current to direct current to operate. See also DC.

address

A label, name, or number that identifies a location in computer memory.

ASCII

(American Standard Code for Information Interchange) A standard number assigned to each of the alphanumeric characters and keyboard control code keys to enable the transfer of information between different types of computers and peripherals.

B

backplane slot

A connector on the backplane board in desktop computers and expansion boxes that allows you to install circuit cards.

backup

A copy of data for safe-keeping. The data is copied from computer memory or disk to a floppy disk, magnetic tape, or other media.

backup battery

The battery in your computer that maintains the real-time clock and the configuration information when the computer's power is removed.

base memory

An area of memory between 0 and 640 kilobytes.

baud rate

The speed with which data is transmitted during serial communication. The computer's operating system and software program must be configured for the same baud rate as the communication device, such as a serial printer. See also bps.

BIOS

(Basic Input/Output System) A program stored in flash EPROM or ROM that controls the keyboard, disk drives, video monitor, and other devices. See also flash EPROM, EPROM, and ROM.

bit

Derived from BInary digiT, a bit is the smallest unit of information a computer handles. See also byte.

BMC

(Baseboard Management Controller) Contains all of the server management functions. One major function of the BMC is to monitor system management events and log their occurrence in the System Event Log (SEL).

boot

The process of loading the operating system into memory.

bps

(bits per second) The number of bits transferred in one second during serial communication, such as modem transmission.

byte

A group of eight bits.

C**cache memory**

A very fast, limited portion of RAM set aside for temporary storage of data for direct access by the microprocessor.

CD-ROM drive

(Compact Disk ROM drive) A type of mass storage device that reads information from a compact disk.

Centronics port

An industry standard parallel port. See also parallel port.

CGA

(Color Graphics Adapter) A type of video display system that provides low-resolution text and graphics on TTL monochrome and color monitors.

CMOS

(Complimentary Metal-Oxide Semiconductor) A type of low-power integrated circuit used in computers. See also TTL.

COM1 or COM2

The name you can assign a serial port to set or change its address. See also serial port.

command

An instruction that directs the computer to perform a particular operation.

configuration

The way in which a computer is set up to operate. Some configurable options include CPU speed, serial port designation, and memory allocation.

coprocessor

See math coprocessor.

CPU

(Central Processing Unit) See microprocessor.

CRT

(Cathode-Ray Tube) The type of video display used in monitors for desktop computers.

D**DC**

(Direct Current) The type of current available in the rechargeable battery packs used in portable computers. See also AC.

default

The factory setting your computer uses unless you instruct it otherwise. For example, when powering up, the computer will boot from the default drive.

density

The capacity of information (bytes) that can be packed onto a storage device, such as a floppy disk.

device driver

A software program that a computer must use to recognize and operate certain hardware, such as a mouse or a video monitor.

disk drive

A device that stores data on a hard or floppy disk. A floppy disk drive requires a floppy disk to be inserted; a hard disk drive has a permanently encased hard disk.

DOS

(Disk Operating System) See operating system.

DRAM

(Dynamic RAM) See RAM.

E**ECC**

(Error Checking and Correction) A method of detecting and correcting errors.

EEPROM

(Electrically Erasable Programmable Read-Only Memory) A type of memory device that stores password and configuration information.

EGA

(Enhanced Graphics Adapter) A type of video display system that provides medium-resolution text and graphics on TTL monochrome, color, and enhanced color monitors.

EMP

The Emergency Management Port (EMP) provides an interface to the Console Manager. This interface allows remote server management via a modem or direct connection.

EMS

(Expanded Memory Specification) A method of accessing memory beyond the 640K limit of DOS by exchanging data in and out of main memory at high speeds. Some software requires EMS to operate.

EPROM

(Erasable Programmable Read-Only Memory) A type of memory device that is usually used to store system BIOS code. This code can be erased with ultraviolet light, but is not lost when the computer is powered off. See also flash EPROM and ROM.

expanded memory

See EMS.

expansion slot

See backplane slot.

extended memory

The protected memory above 1M that is directly accessible by the microprocessor through certain utilities and operating systems. This memory is used in computers with 80286, 80386, and 80486 microprocessors.

F**flash EPROM**

A type of memory device that is usually used to store system BIOS code. This code can be replaced with updated code from a floppy disk, but is not lost when the computer is powered off. See also EPROM and ROM.

floppy disk drive

See disk drive.

format

The process used to organize a hard or floppy disk into sectors so it can accept data. Formatting destroys all previous data on the disk.

G**(Gigabyte)**

1,073,741,824 bytes. See also byte.

H

hard disk drive

See disk drive.

hardware

The physical parts of your computer, including the keyboard, monitor, disk drives, cables, and circuit cards.

hot swap

A method used to insert or remove SCSI disk drives into or from an operating bus. This method is typically used in RAID subsystems. When used in non-RAID subsystems the operating system must typically be restarted.

I

IC

(Integrated Circuit) An electronic device that contains miniaturized circuitry.

(ISA Configuration Utility)

The program that you use to change the configuration of some ISA desktop computers. This program also contains information about the hardware in the computer.

IDE

(Integrated Drive Electronics) A type of hard disk drive with the control circuitry located inside the disk drive rather than on a drive controller card.

interface.

A connection between the computer and a peripheral device that enables them to exchange data. See also parallel port and serial port.

ISA

(Industry Standard Architecture) An industry standard for computers and circuit cards that transfer 16 bits of data at a time.

J

jumper

A small electrical connector used for configuration on some computer hardware.

K

(Kilobyte)

1,024 bytes. See also byte.

L

LAN

(Local Area Network) A group of computers linked together within a limited area to exchange information.

LCD

(Liquid Crystal Display) The type of video display used in portable computers.

LED

(Light-Emitting Diode) A small electronic device that glows when current flows through it.

LPT1 or LPT2

The name you can assign a parallel port to specify its address. See also parallel port.

LVD

Super-fast Ultra 2 SCSI Low Voltage Differential (LVD) Parallel SCSI Interface. A new SCSI interface that provides greater I/O bandwidth, device connectivity, data reliability, and longer cable lengths for Ultra2 SCSI hard disk drives. Note that in order to achieve LVD performance all devices including cable, controller, and drive must support LVD.

M

(Megabyte)

1,048,576 bytes. See also byte.

math coprocessor

An IC that works with the microprocessor to speed up mathematical calculations.

memory

The circuitry in your computer that stores data and programs. See also EMS, extended memory, RAM, and ROM.

microprocessor

The integrated circuit that processes data and controls the basic functions of the computer.

modem

A device used to exchange information with other computers over telephone or data lines.

module

A circuit board that plugs into a dedicated connector on the system board in your computer.

mouse

A small input device that you guide on a flat surface to control the cursor movement and operation of the computer when using certain software programs.

N

NVRAM

(Nonvolatile RAM) A type of RAM that retains its contents even after the computer is powered off. This memory stores EISA configuration information. See also RAM and SRAM.

O

operating system

A set of programs that provides the interface between other software programs and the computer.

P

parallel port

The connector on the back of your computer that allows the transfer of data between the computer and a parallel device, such as a parallel printer.

partition

The process of dividing the storage space on a hard disk into separate areas so that the operating system treats them as separate disk drives.

password

A security feature that prevents an unauthorized user from operating your computer. See also EEPROM.

PCI

Peripheral Component Interconnect. PCI is a high-performance peripherals I/O bus supporting data transfers of up to 132MB per second.

Pentium

A type of microprocessor, with a built-in math coprocessor, cache memory, and memory and bus controllers, that processes and communicates 32 bits of data at a time. This microprocessor also contains power management capabilities.

peripheral

A device connected to and controlled by the computer, such as an external disk drive or a printer.

pixel

The smallest element that is visible on a video display. The resolution of a video display system is measured in pixels.

PnP

(Plug-n-Play) Plug-and-play is the ability to plug a device into a computer and have the computer recognize that the device is there. The user doesn't have to tell the computer.

POST

Power-On-Self-Test.

R**RAM**

(Random-Access Memory) A temporary storage area for data and programs. This type of memory must be periodically refreshed to maintain valid data, and is lost when the computer is powered off. See also NVRAM and SRAM.

real-time clock

The IC in your computer that maintains the time and date.

ROM

(Read-Only Memory) A type of memory device that usually is used to store system BIOS code. This code cannot be altered and is not lost when the computer is powered off. See also BIOS, EPROM, and flash EPROM.

RS-232C port

An industry standard serial port. See also serial port.

S**SAF-TE**

(SCSI Accessed Fault Tolerant Enclosure) A specification for monitoring the state of the drives and enclosure environment (fan, power supply, temperature, etc.) using the SCSI bus to indicate faults.

save

To store information on a floppy disk, hard disk, magnetic tape, or some other permanent storage device.

SCSI

(Small Computer System Interface) An industry standard interface that provides high-speed access to tape drives, hard disk drives, and other peripheral devices.

SEL

(System Event Log) A record of system management events. The information stored includes the name of the event, the date and time the event occurred and data pertinent to the event. Event data may include POST error codes that reflect hardware errors or software conflicts within the system.

serial communication

Information sent sequentially, one bit at a time.

serial port

The connector on the back of your computer that allows the transfer of data between the computer and a serial device, such as a mouse, a modem, or a serial printer.

Setup program

The program that you use to change the configuration of some ISA desktop and notebook computers. This program also contains information about the hardware in the computer.

software

Programs with specific functions, such as word processing, data base management, communications, and operating system.

SRAM

(Static RAM) A temporary storage area for data and programs. This type of memory does not need to be refreshed, but it is lost when the computer is powered off. See also NVRAM and RAM.

SSU

(System Setup Utility) The program that you use to change the configuration of your system. This program also contains information about the hardware in your system and is used to read the System Event Log.

SVGA

(Super VGA) A type of video display system that provides very high-resolution text and graphics on analog color monitors.

system board

The main circuit board in your computer. It contains most of the connectors and ports.

T**tape drive**

A type of storage device using magnetic tape.

TTL

(Transistor-Transistor Logic) A type of integrated circuit used in computers. See also CMOS.

V**VGA**

(Video Graphics Array) A type of video display system that provides high-resolution text and graphics on analog color monitors.

Equipment Log

Use this equipment log form to record pertinent information about your system. You will need some of this information to run the System Setup Utility. Be sure to update the equipment log when you add options.

Record the model and serial numbers of the system components, dates of component removal or replacement, and the name of the vendor from whom the component was purchased. Be sure to record the same information for any components added to the system, such as hard disk drives, add-in boards, or printers.

Record the model and serial numbers of the unit and system baseboard. The model and serial numbers of the system unit are recorded on a label attached to the rear of the unit. The serial number of the system board is located along the left side of the board, near the PCI expansion slot covers.

The location of serial numbers on add-in boards, hard disk drives, and external equipment, such as video displays or printers, varies from one manufacturer to another. Literature accompanying these products should illustrate or describe the location of model and serial numbers.

| Component | Manufacturer Name & Model | Serial Number (if available) | Date Installed |
|--------------------------|--------------------------------------|---|-----------------------|
| Server | | | |
| System Board | | | |
| Processor 1 | | | |
| Processor 2 | | | |
| DIMM Slot 1 | | | |
| DIMM Slot 2 | | | |
| DIMM Slot 3 | | | |
| DIMM Slot 4 | | | |
| Modem | | | |
| Diskette Drive A | | | |
| Diskette Drive B | | | |
| Tape Drive 1 | | | |
| Tape Drive 2 | | | |
| CD-ROM Drive 1 | | | |
| Hard Disk Drive 1 | | | |
| Hard Disk Drive 2 | | | |
| Hard Disk Drive 3 | | | |
| Hard Disk Drive 4 | | | |
| Hard Disk Drive 5 | | | |
| Hard Disk Drive 6 | | | |
| Hard Disk Drive 7 | | | |
| Optional RAID Controller | | | |
| Network Controller 1 | | | |
| Network Controller 2 | | | |
| Monitor | | | |
| Keyboard | | | |
| Mouse | | | |
| External Peripheral 1 | | | |
| External Peripheral 2 | | | |
| | | | |
| | | | |
| | | | |

Index

A

- Add-in boards
 - ISA, B-2
 - PCI, B-2
- Administrative password, 1-14
- Advanced Menu, configuring in Setup, 3-9

B

- Battery
 - installing, 7
- BIOS
 - recovering, 3-29
- BMC, 1-13
- Boot block write protect default jumper, 3-29
- Boot menu, configuring, Setup, 3-17

C

- Caution
 - leave boot block protect jumper at default, 3-29, 3-31
- CFG files, B-2
- Chassis intrusion detection default jumper, 3-31
- Configuring system board jumpers
 - boot block protect, 3-29
 - chassis intrusion detection, 3-31
 - summary description, 3-27
- Controller
 - network, 1-11
 - system board management (BMC), 1-13

E

- Emergency Management Port
 - FRU viewer, C-18
 - main console window, C-7
 - phonebook, C-12
 - requirements, C-5
 - SDR viewer, C-17
 - SEL viewer, C-13
 - server control operations, C-9
- Emergency Management Port Console, C-2
- EMP. *See* Emergency Management Port Console
- Exit menu, configuring, Setup, 3-19

H

- Hard Drive menu
 - configuring, Setup, 3-18

I

- Integrated Peripheral Configuration menu,
 - configuring in Setup, 3-11
- Intrusion detection, 1-13, 1-14
- ISA feature summary, 1-10

J

- Jumpers
 - BMC forced boot, 3-27
 - boot block write protect, 3-27
 - boot option, 3-27
 - chassis intrusion detection, 3-27
 - CMOS clear, 3-27
 - password, 3-27
 - recovery boot, 3-27

L

- LAN status, 2-13
- Lithium backup battery
 - installing, 7

M

- Memory
 - addresses, 1-9
- Monitoring system status, 1-13

N

- Network
 - controller, 1-11

O

- Overview, 1-2
- OVL files, B-2

P

- Password
 - administrative, 1-14
 - user, 1-14
- PCI Device, Slot 1 - Slot 7 menu, configuring in Setup, 3-10
- PCI feature summary, 1-10
- Power supply
 - monitoring power state, 1-13
- Problems
 - bootable CD-ROM not detected, 5-14
 - CD-ROM drive activity light, 5-12
 - F2 key prompt does not appear, 5-12
 - network, 5-15
 - PCI installation tips, 5-16

R

- Real-time clock
 - running SCU to configure settings, 7
- Removing termination board, 10, 12

S

- SCI files, B-2
- SCU
 - software locking feature, 1-14
- Security, 1-14
 - alarm switches, 1-14
 - software lock, SCU, 1-14
- Security menu
 - configuring, Setup, 3-12
- Server management
 - BMC, 1-13
 - features, 1-13
 - intrusion detection, 1-14
- Server Management Information menu,
 - configuring in Setup, 3-16
- Server menu, configuring in Setup, 3-14
- Setup
 - Advanced menu, 3-9
 - Boot menu, 3-17
 - Exit menu, 3-19
 - Hard Drive menu, 3-18
 - Integrated Peripheral Configuration menu,
 - 3-11
 - PCI Device, Slot 1 - Slot 7 menu, 3-10
 - Security menu contents, 3-12
 - Server Management Information menu
 - contents, 3-16
 - Server menu contents, 3-14
- Switches
 - alarm, 1-14
- System board
 - boot block protect, jumper, 3-29
 - chassis intrusion detection, jumper, 3-31
 - configuration jumpers, 3-27
- System Chassis, 1-5
- System setup utility
 - CFG files, B-2
 - customizing, B-5
 - defining an ISA card, B-8
 - exiting, B-15
 - launching a task, B-6
 - OVL files, B-2
 - removing an ISA card, B-9
 - running, B-4
 - SCI files, B-2
 - when to run, B-2

T

- Termination board
 - removing, 10, 12

U

- User password, 1-14
- Utilities
 - Emergency Management Port Console, C-2

W

- Write protect boot block, jumper, 3-29

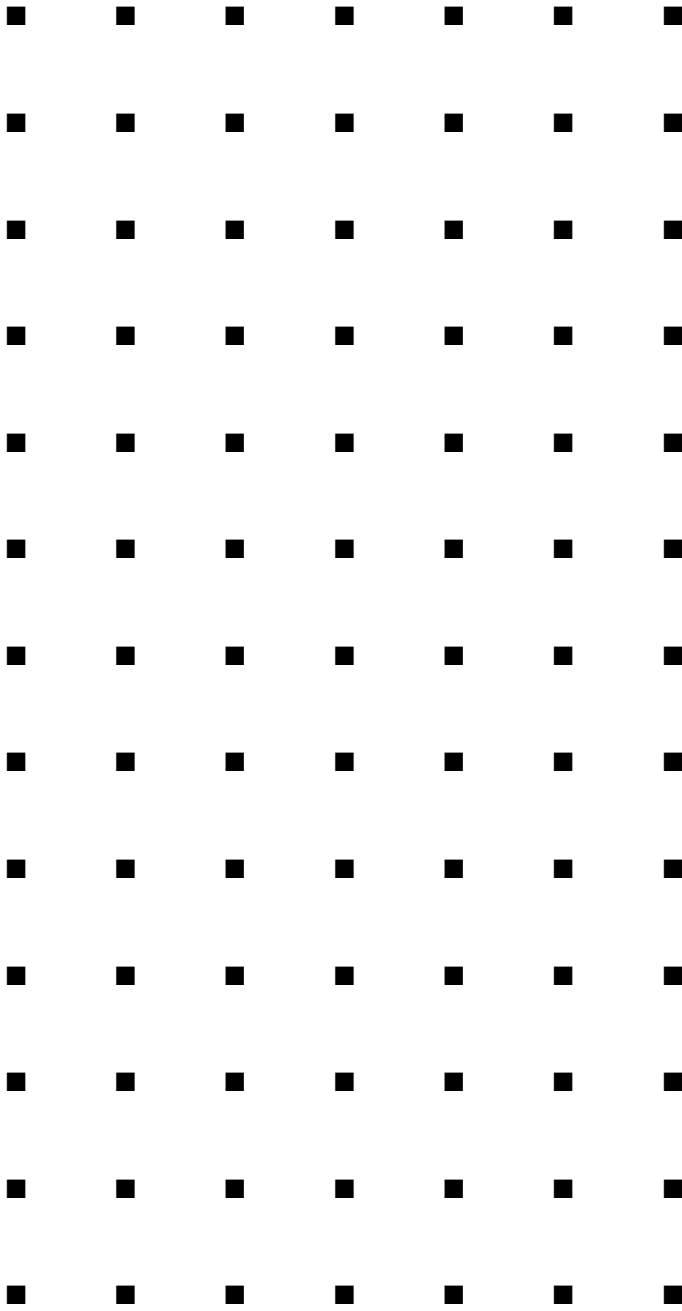

102173-02