

Electronic Vibration Switch (EVS)



Also available, optional internal battery powered EVS switch model, designed for use on ignition powered systems.

Features

- Piezoelectric-crystal internal sensor with built-in microelectronics for reduced noise sensitivity
- Electronically integrated output signal that measures and trips on velocity
- Adjustable calibrated set-point controls
- Shutdown set-point measured in velocity
- Optional 4-20 mA output for continuous monitoring capability
- Solid-state outputs for setpoint trip
- Adjustable time delay to prevent false tripping on high-vibration start-ups or non-repetitive transient events
- Self-test and calibration

The **Electronic Vibration Switch (EVS)** protects against equipment failure by monitoring velocity-based vibration levels and providing an early warning or shutdown when abnormal vibration is detected.

The EVS product can be connected to Murphy's TTD™ annunciator, Centurion™ or Millennium™ controllers for increased functionality. It also complements Murphy's VS2™ shock and excessive vibration/pulsation switch, which is designed to detect an abnormal shock or pulsation due to equipment failure and to shutdown other equipment in a system to prevent further damage.

The EVS product can be used on any equipment where abnormal vibration could lead to equipment damage, including:

- Cooling fans
- Engines
- Pumps
- Compressors
- Gear boxes
- Motors
- Generator sets

The EVS product can monitor and alert the operator of abnormal vibration caused by a variety of possible factors, including:

- Imbalance and misalignments
- Defective sleeve bearings
- Broken tie down bolts
- Defective ball or roller bearings
- Gear mesh
- Blade pass frequencies
- Detonation
- Broken parts

EVS Product Table				
Model	Power	Bandwidth	Analog Out	Area Classification*
EVS-S	24 VDC	6-500Hz	No	CL I, Gr C,D, Div 2
EVS-A	24 VDC	6-500Hz	Yes	CL I, Gr C,D, Div 2
EVS-SB	Internal Battery	6-350Hz	No	CL I, Gr C,D, Div 2
EVS-S-EX	24 VDC	6-500Hz	No	CL I, Gr C,D, Div 1
EVS-A-EX	24 VDC	6-500Hz	Yes	CL I, Gr C,D, Div 1

*Submitted for approval

EVS --

Model:
S = Standard (24VDC external power, switch only)
A = Analog (24VDC external power, switch and 4-20mA output)
SB = Internal Battery (switch only)
S-EX = Standard (24VDC external power switch only, Div 1 Housing)
A-EX = Analog (24VDC external power, switch and 4-20mA output, Div 1 Housing)



www.fwmurphy.com
(918) 317-4100 sales@fwmurphy.com

Specifications

Environmental

- Operating Temperature: -40°F to 185°F (-40°C and +85°C).
- Humidity: 0-95% non-condensing
- Vibration: 30 g's (Mechanical stability)

Power Requirements

Murphy EVS-SB – Internal Battery Power

- Battery power provided via 7.2V V lithium-Ion cell(s)
- Open circuit maximum voltage of 10VDC.
- Batter Life – 1 year under normal operation
- Normal operation 10v > Vbat > 6.4v
- Low battery mode: 5.0v < Vbat < 6.4v
- System shutdown and alarm mode active below 5.0v

Murphy EVS-A, EVS-S – External DC Power

- External power: 8-32 VDC
- Input Current: 100mA Max

Product Accuracy

- ±5% of full scale at 1.5 ips and 21 deg C.
- ±5% Variation over temperature from 21 deg C, over operating range..
- Integration Stage End-to-End Noise: <0.01 ips RMS

Murphy EVS-S and EVS-A

- ±5%, at Bandwidth of 6 to 500 Hz from 50Hz calibration point
- ±3dB at Bandwidth of 3 to 875 Hz, worst case

Murphy EVS-SB

- ±5%, at Bandwidth of 6 to 350 Hz from 50Hz calibration point
- ±3dB at Bandwidth of 3 to 875 Hz, worst case

Trigger Feature

- Trigger level between 0.1 and 1.5 inches per second (ips) Peak
- Trigger set with single turn adjustable PC board mount potentiometer
- PC board marked with 15 marks corresponding to 0.1 to 1.5 in 0.1 increments

Time Delay Feature

- Adjustable from 0 to 10 seconds
- Set with adjustable single turn PC board mount potentiometer
- PC board marked with 11 marks corresponding to 0 to 10 seconds in 1 second intervals

Output

- Normally-Open and Normally-Closed outputs simultaneously available
- Open-collector outputs sink to Common Ground
- 50 mA sink capacity
- Input voltage: 40 VDC maximum

- Switch output is selectable for latched or non-latch configurations. Reset accomplished by reset pushbutton or external contact closure when in latch mode.
- Shutdown Alarm activated on power loss

LED Outputs

Alarm LED output

- Red LED
- LED strobing for first 5 minutes after entering Alarm mode
- Flashing thereafter until Reset activated
- Strobe rate: 2mSec on, every 0.5 ±0.25 seconds
- Flash rate: 2mSec on, every 6 ±1 seconds

Power LED output

- Green LED
- Flash Duration: 2mSec

Murphy EVS-S and EVS-A

- Flash once every 6 ±1 seconds

Murphy EVS-SB

- Battery status "Normal": Flash once every 6 ±1 seconds
- Battery in "Low-Battery" range: Flash once every 12±1 seconds

4-20mA output (EVS-A only)

- Power obtained from power supply
- Loop Resistance: 600 ohms max at 24 V and 20mA.
- Current loop accuracy ±5% from internal setpoint
- 20 ma corresponds to 1.5 ips Peak
- 4 ma corresponds to 0 ips Peak

Reset

- Local reset switch w/momentary contact
- External reset: Available via header and will require an external relay or pushbutton contact to ground to activate the reset.
- Activation Period: Reset must be active for 0.5 sec. minimum to reset the switch.

Circuit Functional blocks

- Charge Amp interface
 - The input Transducer is an integrated PZT element for measuring acceleration with an internal charge converter.
 - Maximum G level of 13 g's at 500hz
- Bandpass Filter
 - Frequency response dependent on model number (refer to "Product Accuracy")
- Integration
 - Integration to convert from G to IPS peak

Approvals

- Hazardous Area approvals applied for. (refer to "Product Table")
NMEA 4

Product Dimensions and Sensitivity Axis

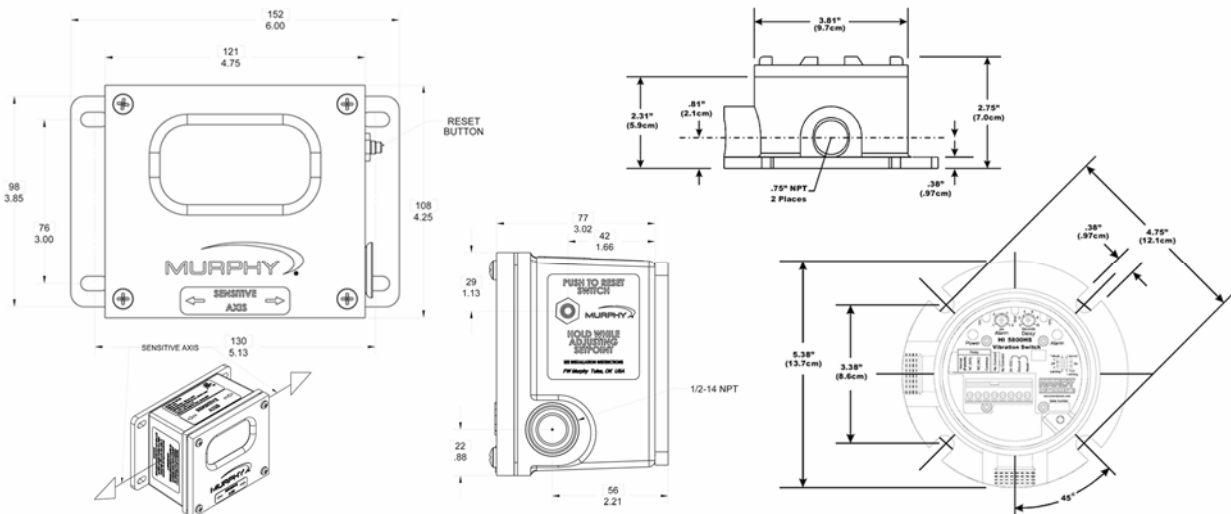

Warranty - A limited warranty on materials and workmanship for one year is given with this FW Murphy product. A copy of the warranty may be viewed or printed by going to www.fwmurphy.com/support/warranty.htm