

# *Grizzly* **Industrial, Inc.**®

## **JUMP STARTER/COMPRESSOR**

**MODEL H6310**

## **INSTRUCTION MANUAL**



COPYRIGHT © SEPTEMBER, 2004 BY GRIZZLY INDUSTRIAL, INC.

**WARNING: NO PORTION OF THIS MANUAL MAY BE REPRODUCED IN ANY SHAPE OR FORM WITHOUT THE WRITTEN APPROVAL OF GRIZZLY INDUSTRIAL, INC.**

#TR6648 PRINTED IN CHINA



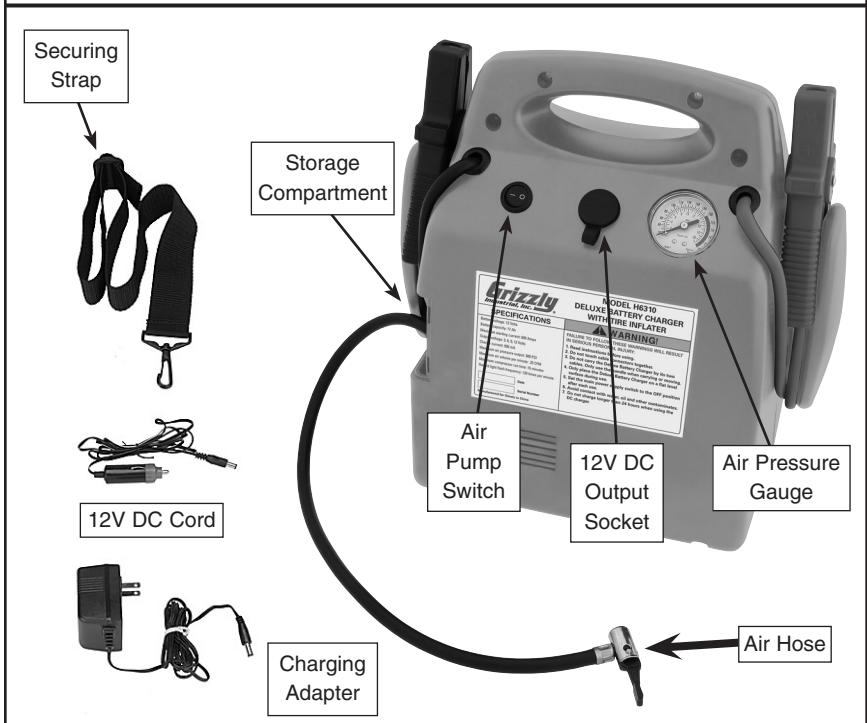
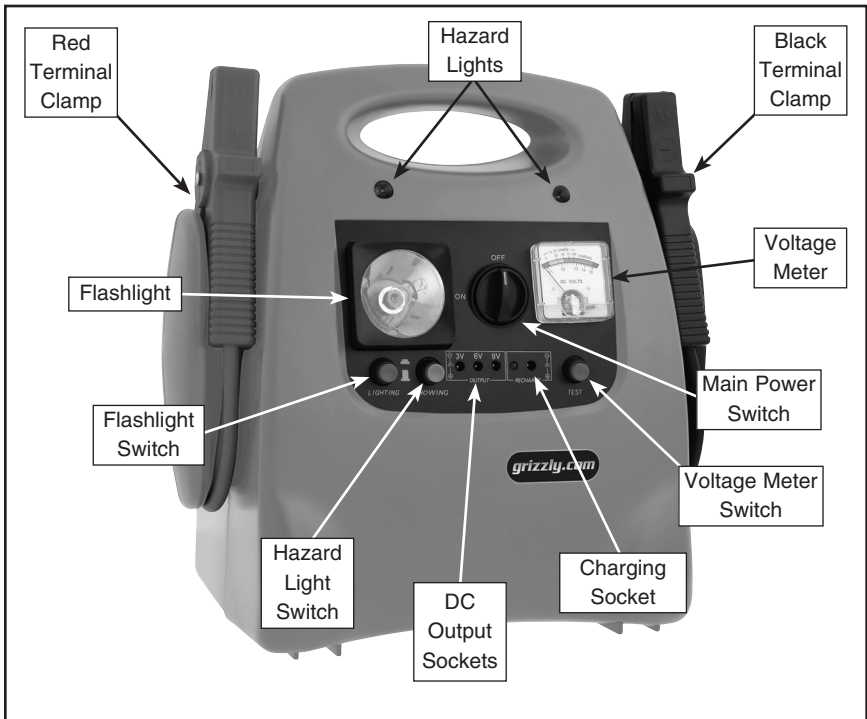

Model H6310 Jump Starter/Compressor

# SAFETY

## WARNING

### For Your Own Safety Read Instruction Manual Before Operating This Equipment

The purpose of safety symbols is to attract your attention to possible hazardous conditions. This manual uses a series of symbols and signal words which are intended to convey the level of importance of the safety messages. The progression of symbols is described below. Remember that safety messages by themselves do not eliminate danger and are not a substitute for proper accident prevention measures.



Indicates an imminently hazardous situation which, if not avoided, WILL result in death or serious injury.



**WARNING**

Indicates a potentially hazardous situation which, if not avoided, COULD result in death or serious injury.



**CAUTION**

Indicates a potentially hazardous situation which, if not avoided, MAY result in minor or moderate injury. It may also be used to alert against unsafe practices.

**NOTICE**

This symbol is used to alert the user to useful information about proper operation of the equipment.

## WARNING

### Safety Instructions for Machinery

- 1. READ THROUGH THE ENTIRE MANUAL BEFORE STARTING MACHINERY.** Machinery presents serious injury hazards to untrained users.
- 2. MAKE SURE ALL GUARDS ARE IN THEIR CORRECT PLACE AND WORK CORRECTLY BEFORE USING MACHINERY. NEVER OPERATE MACHINE WITHOUT GUARDS.**
- 3. ALWAYS USE ANSI APPROVED SAFETY GLASSES WHEN OPERATING MACHINERY.**
- 4. WEAR PROPER APPAREL. DO NOT** wear loose clothing, gloves, neckties, rings, or jewelry which may get caught in moving parts. Wear protective hair covering to contain long hair and wear non-slip footwear.
- 5. NEVER OPERATE MACHINERY WHEN TIRED, OR UNDER THE INFLUENCE OF DRUGS OR ALCOHOL.** Be mentally alert at all times when running machinery.

6. **ONLY ALLOW TRAINED AND PROPERLY SUPERVISED PERSONNEL TO OPERATE MACHINERY.** Make sure operation instructions are safe and clearly understood.
7. **KEEP CHILDREN AND VISITORS AWAY.** Keep all children and visitors a safe distance from the work area.
8. **MAKE WORKSHOP CHILD PROOF.** Use padlocks, master switches, and remove start switch keys.
9. **NEVER LEAVE WHEN MACHINE IS RUNNING.** Turn power *OFF* and allow all moving parts to come to a complete stop before leaving machine unattended.
10. **DO NOT USE IN DANGEROUS ENVIRONMENTS.** DO NOT use machinery in damp, wet locations, or where any flammable or noxious fumes may exist.
11. **KEEP WORK AREA CLEAN AND WELL LIT.** Clutter and dark shadows may cause accidents.
12. **USE A GROUNDED EXTENSION CORD RATED FOR THE MACHINE AMPERAGE.** Undersized cords overheat and reduce voltage. Replace extension cords if they become damaged. DO NOT use extension cords for 220V machinery.
13. **ALWAYS DISCONNECT FROM POWER SOURCE BEFORE SERVICING MACHINERY.** Make sure switch is in *OFF* position before reconnecting.
14. **MAINTAIN MACHINERY WITH CARE.** Keep blades sharp and clean for best and safest performance. Follow instructions for lubricating and changing accessories.
15. **REMOVE ADJUSTING KEYS AND WRENCHES.** Make a habit of checking for keys and adjusting wrenches before turning *ON* machinery.
16. **CHECK FOR DAMAGED PARTS BEFORE USING MACHINERY.** Check for binding and alignment of parts, broken parts, part mounting, loose bolts, and any other conditions that may affect machine operation. Repair or replace damaged parts.
17. **USE RECOMMENDED ACCESSORIES.** Refer to the instruction manual for recommended accessories. The use of improper accessories may cause risk of injury.
18. **DO NOT FORCE MACHINERY.** Work at the speed for which the machine or accessory was designed.

# **WARNING**

## **Additional Safety Instructions for the Jump Starter/Compressor**

- 1. READ THIS MANUAL:** This manual contains proper operating instructions for this jump starter/compressor.
- 2. AVOID SHORTING TERMINAL CLAMPS:** Touching red and black terminal clamps together will cause a short and may cause an explosion or fire. Never touch red and black terminal clamps together!
- 3. MAIN POWER SWITCH:** The main power switch allows you to cut power to the terminal clamps to avoid shorting them during removal from a battery or during trunk storage. Always turn the main power OFF after using and for storage.
- 4. DC CHARGER:** This jump starter/compressor uses a DC charger. Using an AC charger with this model may cause fire or explosion.
- 5. SECURING STRAP:** The securing strap is provided to help you keep the jump starter/compressor away from fans and drive belts. Contact with these items may cause personal injury or damage to the equipment.
- 6. ATTACHING TO BATTERY TERMINALS:** Connecting the terminal clamps to the wrong battery terminals can lead to fire or explosion. Always connect the red terminal clamp to the positive battery terminal and the black terminal clamp to the negative battery terminal.
- 7. AVOID CONTACT WITH WATER:** Besides damaging the jump starter/compressor, contact with water may cause a short or may cause you to get shocked by the current in the terminal clamps.

# **CAUTION**

No list of safety guidelines can be complete. Every environment is different. Always consider safety first, as it applies to your individual working conditions. Use this jump starter/compressor with caution and respect. Failure to do so could result in serious personal injury, damage to equipment or poor results.

# INTRODUCTION

## Foreword

We are proud to offer the Grizzly Model H6310 Jump Starter/Compressor. This model is part of a growing Grizzly family of fine power tools. When used according to the guidelines set forth in this manual, you can expect years of trouble-free, enjoyable operation and proof of Grizzly's commitment to customer satisfaction.

The Model H6310 is designed to be charged from a 110V outlet, then stowed away in an automobile for later use. The Model H6310 features a flashlight, hazard lights, a jump starter, a tire inflater, and four DC outlets for powering various DC operated accessories.

It is our pleasure to provide this manual with the Model H6310. It was written to encourage safety considerations and guide you through general operating procedures and maintenance.

The specifications, details, and photographs in this manual represent the Model H6310 as supplied when the manual was prepared. However, owing to Grizzly's policy of continuous improvement, changes may be made at any time with no obligation on the part of Grizzly.

## Machine Data

Charging Source..... 110V  
DC Output..... 3V, 6V, 9V & 12V  
Max. Air Compressor Run Time .....15 Min  
Rated Air Exhaust Volume .....0.35 CFM  
Jump Start Current ..... 600 A  
Charging Current .....500 mA  
Hazard Blink Frequency ..... 120 per minute  
Illumination Power ..... 6 Watts

Model H6310 Jump Starter/Compressor

## Contact Info

If you have any comments regarding this manual, please write to us at the following address:

Grizzly Industrial, Inc.  
C/O Technical Documentation  
P.O. Box 2069  
Bellingham, WA 98227-2069

Most importantly, we stand behind our tools. If you have any service questions or parts requests, please call or write us at the location listed below.

Grizzly Industrial, Inc.  
1203 Lycoming Mall Circle  
Muncy, PA 17756  
Phone: (570) 546-9663  
Fax: (800) 438-5901  
E-Mail: [techsupport@grizzly.com](mailto:techsupport@grizzly.com)  
Web Site: <http://www.grizzly.com>

## WARNING

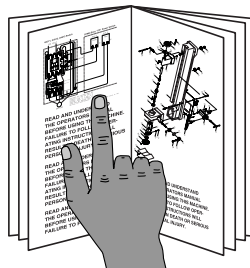

**Read the manual before operation. Become familiar with this jump starter/compressor, its safety instructions, and its operation before beginning any work. Serious personal injury may result if safety or operational information is not understood or followed.**

# SET UP

---

---

## Unpacking

---

---

Your jump starter/compressor left our warehouse in a carefully packed crate or box. If you discover damage after you have signed for delivery, *please immediately call Customer Service at (570) 546-9663 for advice.*

Save the containers and all packing materials for possible inspection by the carrier or its agent. *Otherwise, filing a freight claim can be difficult.*

When you are completely satisfied with the condition of the shipment, you should inventory the equipment.

---

---

## Inventory

---

---

After you have unpacked the carton you should find the following.

### Model H6310 Inventory (Figure 1)

A. Main Unit.....	1
B. Charging Adapter Cord.....	1
C. 12V Output Cord.....	1
D. Securing Strap .....	1

---

---

## Charging

---

---

The Model H6310 is shipped with a charging adapter that fits neatly into the storage compartment.

### To charge the Model H6310:

1. Remove the charging adapter from the storage compartment, and plug it into a 110V electrical outlet.
2. Turn the main power switch ON, and press the "Test" button so the voltage meter shows the charge.
3. Plug the adapter cord into the "Recharge" socket.

— The red light will light up if the Model H6310 is charging.

— If the red light will not light up, the Model H6310 is fully charged.

4. Allow the Model H6310 to charge until the red light turns off or until the voltage meter reaches 13V.
5. Disconnect the Model H6310 from the charger.

## **NOTICE**

**DO NOT charge the Model H6310 for longer than 24 hours or internal damage may result.**



# OPERATIONS

---

---

## Jump Starter

---

---

When jump starting any automobile, always check the actual symbols on the battery to ensure which terminals are positive "+" or negative "-". (DO NOT rely on red or black colors of the cables already connected to the battery, as these are not always consistent.) Also, never touch the red and black terminal clamps together as this will short out the jump starter and may cause fire, explosion, or damage to equipment.

### To use the jump starter:

1. Remove the black and red terminal clamps from the holders.
2. Clip the black terminal clamp on the negative "-" battery terminal.
3. Clip the red terminal clamp on the positive "+" battery terminal.
4. Turn the main power switch *ON*.
5. Start the car.

— If car starts, remove the red terminal clamp first, then the black.

— If car won't start, refer to *Troubleshooting* on **page 9**.

## CAUTION

**Touching red and black terminal clamps together will cause a short and may cause an explosion or fire. Never touch red and black terminal clamps together!**

## Tire Inflater

---

---

The air nozzle is tucked inside the storage compartment that is located near the black terminal clamp. If you are filling a tire at night, and you are on the side of the road near oncoming traffic, use the hazard lights to increase your personal safety.

### To use the tire inflater:

1. Remove the cover to the storage compartment, and pull out the air hose.
2. Clamp the air hose to the tire valve stem.
3. Turn the main power switch *ON*.
4. Push the air pump button to "-" to start the air pump.
5. Fill the tire while monitoring the PSI gauge, and stop the air pump (push button to "O") when the tire is filled to the correct PSI listed on the tire.

## Hazard Lights

---

---

In the event of an emergency, the hazard lights help notify oncoming vehicles of your presence. This is especially important at night when you are working on the side of a road with busy traffic.

### To use the hazard lights:

1. Turn the main power switch *ON*.
2. Press the green "Showing" button.

## Flashlight

---

---

A built-in flashlight is included on the Model H6310 to help you see when you are jump starting a battery or filling a tire.

### To use the built-in flashlight:

1. Turn the main power switch *ON*.
2. Press the red "Lighting" button.

## DC Output Sockets

---

---

Four sockets have been included to power DC appliances that use 3V, 6V, 9V, or 12V power.

### For 3V, 6V, and 9V appliances:

Use the power adapter that came with the appliance or purchase a universal adapter and plug into the corresponding socket.

### For 12V appliances:

Use the included adapter and plug into the large socket on the back of the Model H6310. This socket and plug are also universal with common cigarette lighter sockets or adapters that are found in most automobiles.

## Securing Strap

---

---

The securing strap is included to hang the Model H6310 from the hood of a car. Hanging the Model H6310 will keep it out of the way of moving parts like drive belts and fans.

### To use the securing strap:

1. Make sure the strap is fed through the slide buckle and the slide buckle is halfway up the strap.
2. Wrap the end of the strap (the end WITHOUT the hook on it) around the handle of the Model H6310.
3. Feed the strap end through the slide buckle in the opposite direction.
4. Make sure the slide buckle will hold by lifting the Model H6310 approximately 1" off the ground. If it doesn't hold, you have the strap buckled wrong.
5. Hang the Model H6310 from the car hood and adjust the strap as necessary.

## Storage

---

---

The Model H6310 should be stored with the main power switch turned *OFF*.

# TROUBLESHOOTING

Symptom	Possible Cause	Possible Solution
Car will not jump start.	<ol style="list-style-type: none"> <li>1. Bad connection at car battery posts.</li> <li>2. Car battery has lost too much charge.</li> <li>3. Car battery is dead.</li> </ol>	<ol style="list-style-type: none"> <li>1. Clean battery posts, or rotate terminal clamps on post with firm pressure to establish contact.</li> <li>2. Recharge car battery.</li> <li>3. Replace car battery.</li> </ol>
Flashlight does not work when unit is charged.	<ol style="list-style-type: none"> <li>1. Bulb burned out or damaged.</li> <li>2. Switch is damaged.</li> </ol>	<ol style="list-style-type: none"> <li>1. Replace the bulb.</li> <li>2. Replace switch.</li> </ol>
Unit will not charge.	<ol style="list-style-type: none"> <li>1. Charger or cord is damaged.</li> <li>2. Indicator light burned out, giving the appearance that unit is not charging.</li> <li>3. Unit damaged from charging beyond maximum time of 24 hours (current overload).</li> </ol>	<ol style="list-style-type: none"> <li>1. Replace the charger.</li> <li>2. Monitor charging progress with the voltage meter.</li> <li>3. Replace.</li> </ol>
No output from 3V, 6V, 9V sockets.	<ol style="list-style-type: none"> <li>1. Unit damaged from charging beyond maximum time of 24 hours (current overload).</li> <li>2. Distributor damaged.</li> </ol>	<ol style="list-style-type: none"> <li>1. Replace unit.</li> <li>2. Replace distributor.</li> </ol>
Air pump does not work.	<ol style="list-style-type: none"> <li>1. Switch damaged.</li> <li>2. Air pump damaged.</li> </ol>	<ol style="list-style-type: none"> <li>1. Replace switch.</li> <li>2. Replace air pump.</li> </ol>
12V Socket has no output.	<ol style="list-style-type: none"> <li>1. Cord or plug damaged.</li> <li>2. Socket damaged.</li> </ol>	<ol style="list-style-type: none"> <li>1. Replace cord.</li> <li>2. Replace socket.</li> </ol>
Voltage meter stops or does not work.	<ol style="list-style-type: none"> <li>1. Meter damaged.</li> <li>2. Needle stuck on the face plate.</li> <li>3. Switch damaged.</li> </ol>	<ol style="list-style-type: none"> <li>1. Replace the meter.</li> <li>2. Remove cover and free up the needle.</li> <li>3. Replace switch.</li> </ol>

# Parts Breakdown

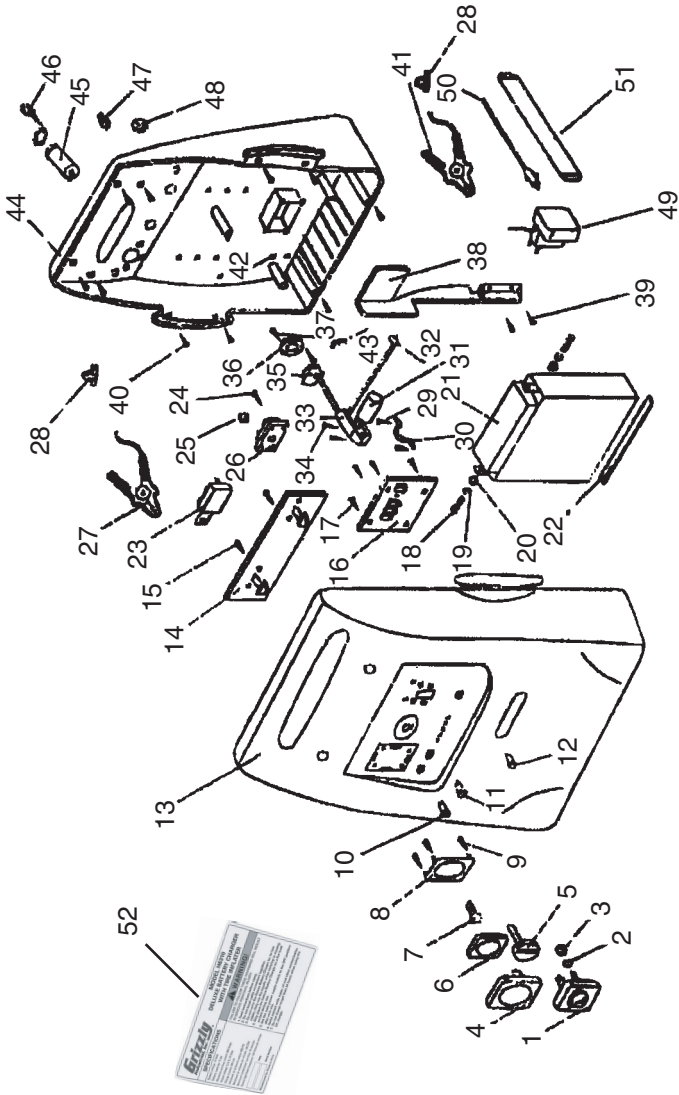

REF	PART #	DESCRIPTION
1	PH6310001	VOLTMETER
2	PW07M	FLAT WASHER 3MM
3	PN07M	HEX NUT M3-.5
4	PH6310004	LAMPSHADE
5	PH6310005	ON/OFF DIAL
6	PH6310006	TRANSPARENT PLATE
7	PH6310007	ILLUMINATING LAMP 12V/6W
8	PH6310008	REFLECTOR
9	PHTEK21M	TAP SCREW M2.9 X 10
10	PH6310010	RED BUTTON, FLASHLIGHT
11	PH6310011	GREEN BUTTON, HAZARD LIGHTS
12	PH6310012	RED BUTTON, VOLTMETER
13	PH6310013	FRONT SHELL
14	PH6310014	FLASH CONTROL PANEL
15	PHTEK21M	TAP SCREW M2.9 X 10
16	PH6310016	VOLT/CHARGE CONTROL PANEL
17	PHTEK22M	TAP SCREW M3.5 X 13
18	PH6310018	BRASS BOLT M5-.8 X 16
19	PLW01M	LOCK WASHER 5MM
20	PN06M	HEX NUT M5-.8
21	PH6310021	STORAGE BATTERY DC12V, 17AH
22	PH6310022	GASKET
23	PH6310023	CURRENT PROTECTOR
24	PHTEK23M	TAP SCREW M3.5 X 19
25	PH6310025	BRASS HEX NUT M6-1
26	PH6310026	POWER SWITCH
27	PH6310027	RED TERMINAL CLAMP W/CABLE
28	PH6310028	WIRE CLAMP
29	PHTEK23M	TAP SCREW M3.5 X 19
30	PH6310030	HOLD-DOWN CLAMP
31	PH6310031	AIR PUMP MOTOR
32	PH6310032	FILLING VALVE W/AIR HOSE
33	PH6310033	PUMP BODY
34	PHTEK2M	TAP SCREW M3.5 X 16
35	PH6310035	PRESSURE METER 20KG/CM2
36	PH6310036	PRESSURE METER WASHER
37	PHTEK21M	TAP SCREW M2.9 X 10
38	PH6310038	GUARD BOARD
39	PHTEK23M	TAP SCREW M3.5 X 19
40	PHTEK23M	TAP SCREW M3.5 X 19
41	PH6310041	BLACK TERMINAL CLAMP W/CABLE
42	PH6310042	SPECIAL WASHER
43	PH6310043	SEMICIRCULAR PAD
44	PH6310044	BACK SHELL
45	PH6310045	CIGARETTE LIGHTER SOCKET
46	PH6310046	SOCKET CAP
47	PH6310047	AIR PUMP SWITCH
48	PH6310048	JACKET
49	PH6310049	DC CHARGING ADAPTER
50	PH6310050	12V DC CIGARETTE LIGHTER CORD
51	PH6310051	SECURING STRAP
52	PH6310052	MACHINE ID LABEL

# WARRANTY AND RETURNS

---

---

Grizzly Industrial, Inc. warrants every product it sells for a period of **1 year** to the original purchaser from the date of purchase. This warranty does not apply to defects due directly or indirectly to misuse, abuse, negligence, accidents, repairs or alterations or lack of maintenance. This is Grizzly's sole written warranty and any and all warranties that may be implied by law, including any merchantability or fitness, for any particular purpose, are hereby limited to the duration of this written warranty. We do not warrant or represent that the merchandise complies with the provisions of any law or acts unless the manufacturer so warrants. In no event shall Grizzly's liability under this warranty exceed the purchase price paid for the product and any legal actions brought against Grizzly shall be tried in the State of Washington, County of Whatcom.

We shall in no event be liable for death, injuries to persons or property or for incidental, contingent, special, or consequential damages arising from the use of our products.

To take advantage of this warranty, contact us by mail or phone and give us all the details. We will then issue you a "Return Authorization Number," which must be clearly posted on the outside as well as the inside of the carton. We will not accept any item back without this number. Proof of purchase must accompany the merchandise.

The manufacturers reserve the right to change specifications at any time because they constantly strive to achieve better quality equipment. We make every effort to ensure that our products meet high quality and durability standards and we hope you never need to use this warranty.

Please feel free to write or call us if you have any questions about the machine or the manual.

**Grizzly Industrial, Inc.**  
**1203 Lycoming Mall Circle**  
**Muncy, PA 17756**  
**Phone: (570) 546-9663**  
**Fax: (800) 438-5901**

**E-Mail:**  
**techsupport@grizzly.com**

**Web Site: <http://www.grizzly.com>**

Thank you again for your business and continued support. We hope to serve you again soon!

# WARRANTY CARD

Name \_\_\_\_\_

Street \_\_\_\_\_

City \_\_\_\_\_ State \_\_\_\_\_ Zip \_\_\_\_\_

Phone Number \_\_\_\_\_ E-Mail \_\_\_\_\_ FAX \_\_\_\_\_

Model # H6310 Jump Starter/Compressor Serial# \_\_\_\_\_ Order # \_\_\_\_\_

The following information is given on a voluntary basis. It will be used for marketing purposes to help us develop better products and services. Of course, all information is strictly confidential.

- How did you learn about us?  
 Advertisement  Friend  
 Catalog  Card Deck  
 World Wide Web  
 Other \_\_\_\_\_
- What is your annual household income?  
 \$20,000-\$29,999  \$60,000-\$69,999  
 \$30,000-\$39,999  \$70,000-\$79,999  
 \$40,000-\$49,999  \$80,000-\$89,999  
 \$50,000-\$59,999  \$90,000 +
- What is your age group?  
 20-29  50-59  
 30-39  60-69  
 40-49  70 +
- How long have you been a woodworker?  
 0 - 2 Years  8 - 20 Years  
 2 - 8 Years  20+ Years
- How would you rank your woodworking skills?  
 Simple  Advanced  
 Intermediate  Master Craftsman
- What stationary woodworking tools do you own?  
Check all that apply.  
 Air Compressor  Panel Saw  
 Band Saw  Planer  
 Drill Press  Power Feeder  
 Drum Sander  Radial Arm Saw  
 Dust Collector  Shaper  
 Spindle Sander  Jointer  
 Table Saw  Lathe  
 Mortiser  Wide Belt Sander  
 Horiz.Boring Machine  
 Vacuum Veneer Press  
 Other \_\_\_\_\_
- How many of your woodworking machines are Grizzly? \_\_\_\_\_
- Which benchtop tools do you own? Check all that apply.  
 1"x42" Belt Sander  6" - 8" Grinder  
 5" - 8" Drill Press  Mini Lathe  
 8" Table Saw  8" - 10" Bandsaw  
 Scroll Saw  Disc/Belt Sander  
 Spindle/Belt Sander  Mini Jointer  
 10"-12" Thickness Planer \_\_\_\_\_  
Other \_\_\_\_\_
- How many of the machines checked above are Grizzly? \_\_\_\_\_
10. Which portable/hand held power tools do you own? Check all that apply.  
 Belt Sander  Orbital Sander  
 Biscuit Joiner  Palm Sander  
 Circular Saw  Portable Planer  
 Detail Sander  Saber Saw  
 Drill/Driver  Reciprocating Saw  
 Miter Saw  Router  
Other \_\_\_\_\_
11. What machines/supplies would you like Grizzly Industrial to carry?  
\_\_\_\_\_  
\_\_\_\_\_  
\_\_\_\_\_
12. What new accessories would you like Grizzly Industrial to carry?  
\_\_\_\_\_  
\_\_\_\_\_  
\_\_\_\_\_
13. What other companies do you purchase your tools and supplies from?  
\_\_\_\_\_  
\_\_\_\_\_  
\_\_\_\_\_
14. Do you think your purchase represents good value?  
 Yes  No
15. Would you recommend Grizzly to a friend?  
 Yes  No
16. Would you allow us to use your name as a reference for Grizzly customers in your area? **Note: We never use names more than three times.**  
 Yes  No
17. Comments: \_\_\_\_\_  
\_\_\_\_\_  
\_\_\_\_\_

Send a Grizzly Catalog to a friend:

Name _____
Street _____
City _____ State _____ Zip _____

FOLD ALONG DOTTED LINE

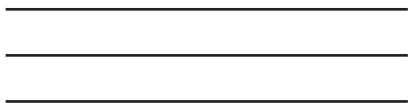

Place  
Stamp  
Here



GRIZZLY INDUSTRIAL, INC.  
P.O. BOX 2069  
BELLINGHAM, WA 98227-2069



TAPE ALONG EDGES--PLEASE DO NOT STAPLE