



Operation/Reference Guide

AXB-TC and AXB-TCR

Television Controllers (& Receivers)



AMX Limited Warranty and Disclaimer

All products returned to AMX require a Return Material Authorization (RMA) number. The RMA number is obtained from the AMX RMA Department. The RMA number must be clearly marked on the outside of each box. The RMA is valid for a 30-day period. After the 30-day period the RMA will be cancelled. Any shipments received not consistent with the RMA, or after the RMA is cancelled, will be refused. AMX is not responsible for products returned without a valid RMA number.

Warranty Repair Policy

- AMX will repair any defect due to material or workmanship issues during the applicable warranty period at no cost to the AMX Authorized Partner., provided that the AMX Authorized Partner is responsible for in-bound freight and AMX is responsible for out-bound ground freight expenses.
- The AMX Authorized Partner must contact AMX Technical Support to validate the failure before pursuing this service.
- AMX will complete the repair and ship the product within five (5) business days after receipt of the product by AMX. The AMX Authorized Partner will be notified if repair cannot be completed within five (5) business days.
- Products repaired will carry a ninety (90) day warranty or the balance of the remaining warranty, whichever is greater.
- Products that are returned and exhibit signs of damage or unauthorized use will be processed under the Non-Warranty Repair Policy.
- AMX will continue to provide Warranty Repair Services for products discontinued or replaced by a Product Discontinuance Notice.

Non-Warranty Repair Policy

- Products that do not qualify to be repaired under the Warranty Repair Policy due to age of the product or Condition of the product may be repaired utilizing this service.
- The AMX Authorized Partner must contact AMX Technical Support to validate the failure before pursuing this service.
- Non-warranty repair is a billable service.
- Products repaired under this policy will carry a ninety (90) day warranty on material and labor.
- AMX will notify the AMX Authorized Partner with the cost of repair, if cost is greater than the Standard Repair Fee, within five (5) days of receipt.
- The AMX Authorized Partner must provide a Purchase Order or credit card number within five (5) days of notification, or the product will be returned to the AMX Authorized Partner.
- The AMX Authorized Partner will be responsible for in-bound and out-bound freight expenses.
- Products will be repaired within ten (10) business days after AMX Authorized Partner approval is obtained.
- Non-repairable products will be returned to the AMX Authorized Partner with an explanation.
- See AMX Non-Warranty Repair Price List for minimum and Standard Repair Fees and policies.

Table of Contents

AXB-TC and AXB-TCR Television Controllers	1
Overview	1
Specifications	2
Applications	3
Installation and Wiring	5
Setting the Device DIP Switch	5
Internal Jumper Settings.....	5
J1 jumper settings: TV power sensing/TV power current sensing mode.....	6
J2 jumper settings: IR output mode (IR or serial communication)	6
J3 jumper settings: IR attenuation mode (bypass or adjustment)	6
Wiring	7
Wiring guidelines	7
Preparing/connecting captive wires	7
TV Sensor connections	7
IR Emitter connections	8
Axlink data and power connections	8
Axlink data and 12 VDC power supply connections.....	8
PCS and Axlink data and power connections	9
PCS and 12 VDC power supply connections	9
Installation	10
Television Power Sensor Adjustment.....	11
IR Signal Attenuation Adjustment.....	11
Replacing the Lithium Battery.....	12
Programming Information	15
Overview	15
Channel Setting Commands.....	15
IR Functions (Standard Order)	16
Send_Commands	17
Firmware Upgrades	21
Using SOFTROM	21
Using NetLinX Studio	22

AXB-TC and AXB-TCR Television Controllers

Overview

The AXB-TC and AXB-TCR Television Controllers are intelligent, microprocessor-controlled systems equipped with a lithium battery to protect stored memory. The television controllers can control a variety of Infrared-controlled devices such as televisions, audio receivers, and videocassette recorders.

FIG. 1 shows the front and rear panels of the AXB-TCR. With the exception of the IR Input Window (on the AXB-TCR only), the TC and TCR share the same front and rear panel components.

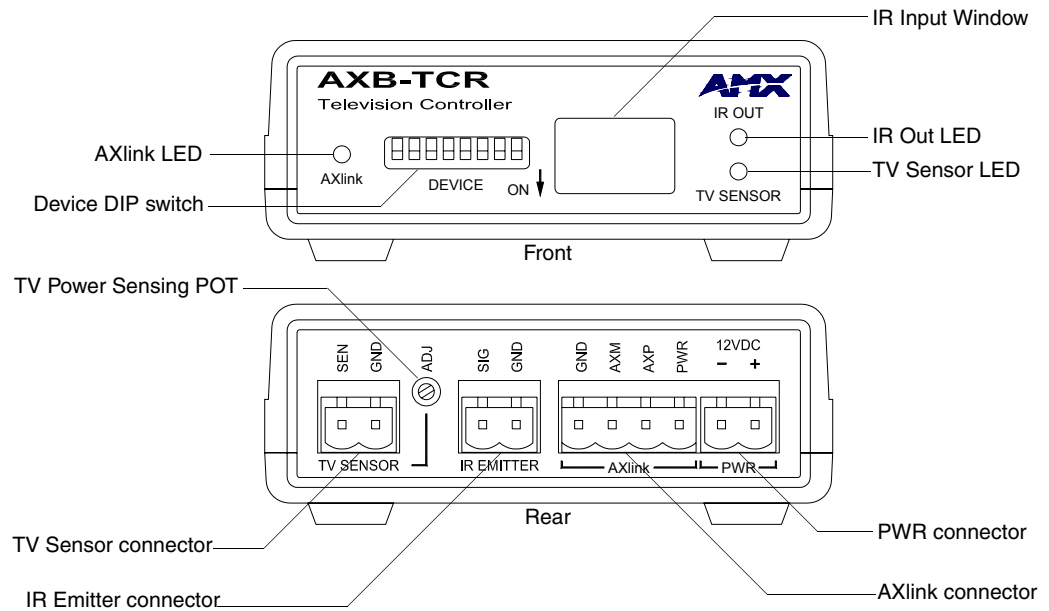

FIG. 1 AXB-TCR front and rear panel components

Specifications

The following table list the product specifications for the television controllers. Other than the IR Input Window (on the AXB-TCR only), the specifications for the TC and TCR are identical.

AXB-TC/TCR Specifications	
Dimensions (HWD): (with connectors)	• 1.29" x 3.33" x 5.54" (32.8 mm x 84.6 mm x 140.6 mm)
Power consumption:	200 mA @ 12 VDC
Front Panel Components:	
LED indicators	<ul style="list-style-type: none"> • AXlink LED (green and blinks to indicate AXlink communication activity and power: • Full-Off indicates no power is being received or the controller is not functioning properly. • One blink per second indicates power is active and AXlink communication is functioning. • Full-On indicates there is no AXlink control or activity, but power is On. <p>IR Out: Red LED blinks when the television controller transmits IR or serial (outgoing) signals.</p> <p>One blink every 2 seconds: The AXB-TC/TCR program is not loaded.</p> <p>TV Sensor: Red LED that lights when the television controller receives, via the CC-IR TV Sensor, the correct horizontal scan frequency signal indicating television or monitor power is on.</p> <p>This LED also lights when the television controller receives a power on status from an AMX PCS Power Control Sensor.</p> <p>One blink every 2 seconds: The AXB-TC/TCR program is not loaded</p>
DEVICE DIP switch	8-position DIP switch that sets the AXlink device number on the AXB-TC and AXB-TCR.
IR Input Window (AXB-TCR only)	Receives 38 kHz IR-control signals from AMX transmitters. The IR input window contains a red LED that lights when receiving IR-control data.
IR Compatibility (AXB-TCR only)	AMX wireless IR control panels and hand-held transmitters (38 kHz only)
Rear Panel components:	
TV Sensor connector	2-pin (male) connector that supports horizontal scan frequency sensing up to 65 kHz with a CC-IR TV Sensor. The connector can also be used with a PCS (Power Current Sensor) to detect television power status (on or off).
TV Sensor POT	Sets the sensitivity to the PCS. You may need to adjust this POT to allow the PCS to detect the television's power status (on or off).
IR Emitter connector	2-pin (male) connector that transmits IR control signals to a television using the CC-IRC IR Emitter cables. The connector also supports transmitting serial control data to an external device.
AXlink connector	4-pin (male) connector that supports AXlink control data communication.
PWR connector	2-pin (male) connector that connects to an external 12 VDC power supply. Refer to the <i>Wiring</i> section on page 7 for external power supply requirements.
Enclosure:	Plastic with black matte finish
Weight:	6 oz. (170 grams)

AXB-TC/TCR Specifications (Cont.)	
Mounting options:	Flat surface
Included accessories:	<ul style="list-style-type: none"> • CC-IR TV Sensor (CC-XPS sensor) • CC-IRC IR Emitter
Optional accessories:	<ul style="list-style-type: none"> • SE-TC Security Enclosure • PCS Power Current Sensor • VSS2 Video Sync Sensor • 12 VDC Power supply

Applications

FIG. 2 shows a sample system configuration.

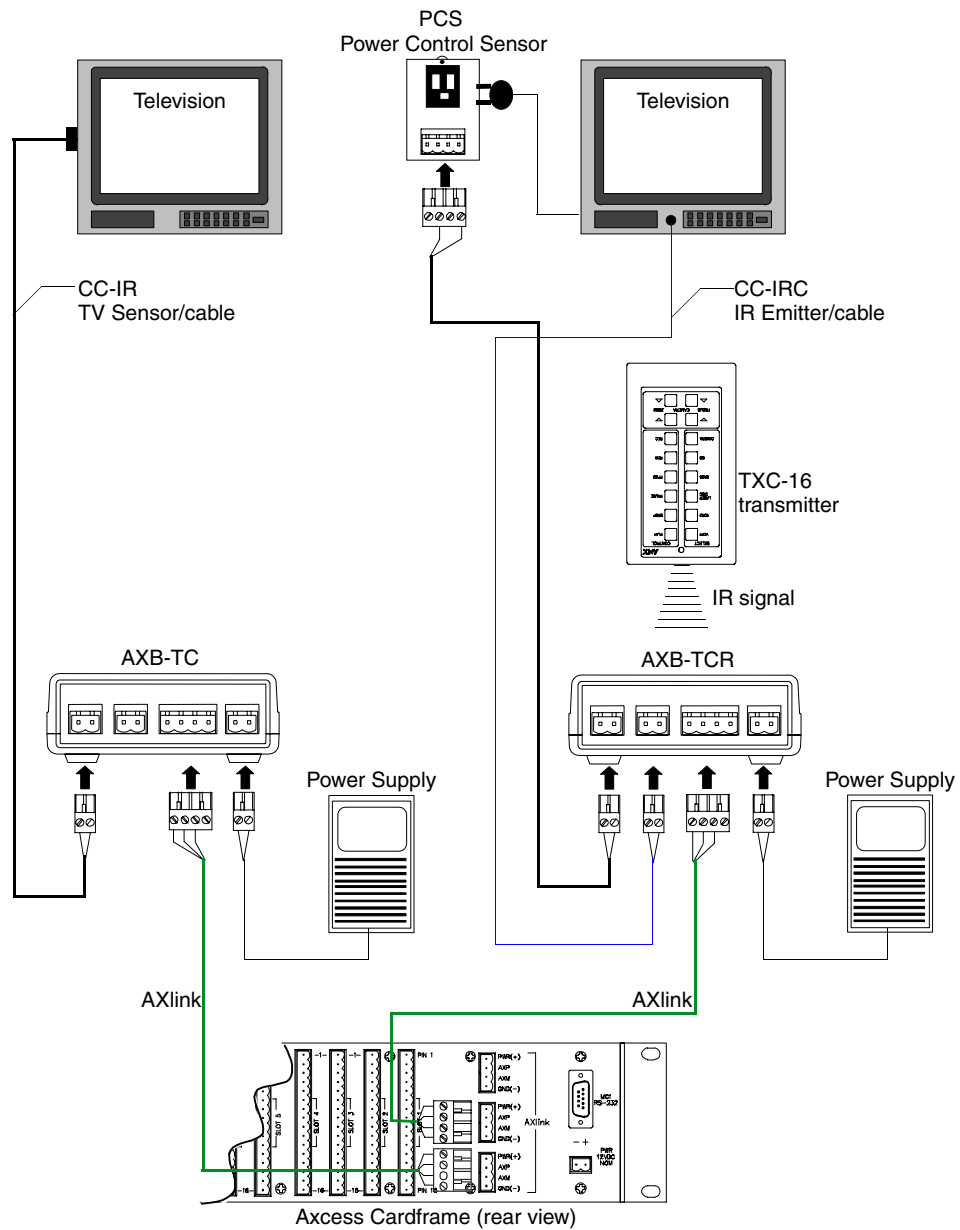

FIG. 2 Sample system application

Installation and Wiring

Setting the Device DIP Switch

The eight-position Device DIP switch sets the identification number for the television controller. Make sure the device number matches the number assigned in the AXCESS software program. The quick reference table below shows the switch positions and their numeric value. In the example below, the numeric value of the Device DIP switch is 97 ($1+32+64=97$).

DIP Switch Settings								
Switch	1	2	3	4	5	6	7	8
Value	1	2	4	8	16	32	64	128

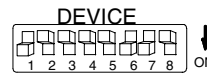

Internal Jumper Settings

The internal jumpers, located on the circuit card inside the television controller enclosure, set the input, output, and IR attenuation modes. Internal jumper modes include:

- **Jumper JP1** sets the input mode for power sensing or power current sensing.
- **Jumper JP2** sets the IR output mode for IR or serial communication.
- **Jumper JP3** sets the IR attenuation mode for bypass or adjustment.

Use a Phillips-head screwdriver to open the enclosure and non-conducting pliers to set the jumpers.



Static electricity can damage electronic circuitry. Before removing the enclosure, discharge any accumulated static electricity from your body by touching a grounded metal object.

1. Unplug all connectors from the rear panel of the television controller.
2. Remove the two Phillips-head screws on the bottom of the enclosure.
3. Pull the two enclosure halves apart and set the bottom portion of the enclosure on a flat surface. FIG. 1 shows the location of the internal jumpers.

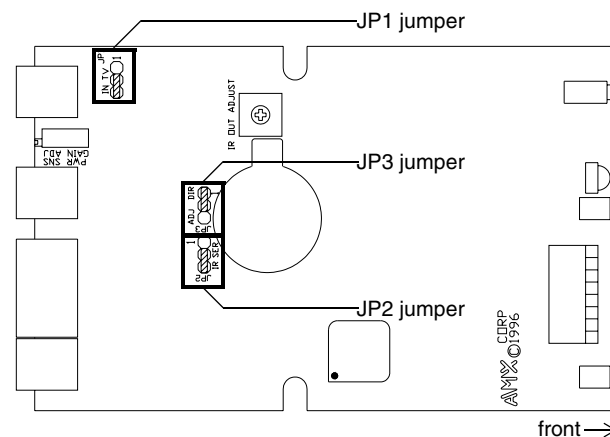

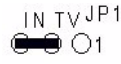



FIG. 1 Internal jumper locations

4. Replace the top portion of the enclosure on the bottom portion. Then, refasten the two Phillips-head screws.



J1 jumper settings: TV power sensing/TV power current sensing mode

J1 Jumper Settings: TV Power Sensing/TV Power Current Sensing		
Television Power Sensing mode	To use this mode, connect a TVS TV Sensor to the television to detect horizontal scan frequencies up to 65 kHz. Place the 2-pin jumper on the JP1 connector pin's 1 and 2.	
Television Power Current Sensing mode	To use this mode, connect a sensor device (such as a PCS2 Dual Power Current Sensor or VSS2 Video Sync Sensor) to the television to detect on and off power status. Place the 2-pin jumper on the JP1 connector pin's 2 and 3.	

J2 jumper settings: IR output mode (IR or serial communication)

J2 Jumper Settings: IR Output Mode (IR or Serial Communication)		
IR Output mode	To use this mode, connect a CC-IRC IR Emitter to the television to transmit IR signals. Place the 2-pin jumper on the JP2 connector pin's 2 and 3.	
Serial (wired connection) Output mode	Place the 2-pin jumper on the JP2 connector pin's 1 and 2.	

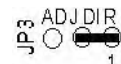
J3 jumper settings: IR attenuation mode (bypass or adjustment)

J3 Jumper Settings: IR Attenuation Mode (Bypass or Adjustment)		
IR Signal Attenuation Bypass mode (normal)	Place the 2-pin jumper on the JP3 connector pin's 1 and 2.	
IR Signal Attenuation Adjustment mode	Place the 2-pin jumper on the JP3 connector pin's 2 and 3. Also, set the JP2 internal jumper for IR emitter mode.	



Refer to the product documentation for the PCS2 Dual Power Current Sensor, VSS2 Video Sync Sensor, TVS TV Sensor and CC-IRC IR Emitter (available online at www.amx.com) for more information on these devices.

Wiring

The TV sensor, IR emitter, AXlink, and 12 VDC power supply connectors are located on the rear panel of the television controller as shown in FIG. 1 on page 1.



Do not connect power directly to the television controller. If you are using power from AXlink, disconnect the wiring from the Central Controller before connecting the wiring to the television controller. If you are using an optional 12 VDC power supply, apply power to the television controller only when installation is complete.

Wiring guidelines

The television controller requires 12 VDC power to operate properly. The power can be supplied via AXlink cable, or with an optional 12 VDC power supply. The maximum wiring distance between the Central Controller and television controller is determined by power consumption, supplied voltage, and the wire gauge used for the cable.

The following table lists wire sizes and the maximum lengths allowable between the television controller and Central Controller. The maximum wiring lengths are based on a minimum of 13.5 volts available at the Central Controller's power supply. If a television controller is installed farther away from the Central Controller than recommended in the table, connect a 12 VDC power supply to the 2-pin 12 VDC PWR connector on the rear panel.

Wiring Guidelines - TC - 175 mA	
Wire size	Maximum wiring length
18 AWG	670.69 feet (204.43 meters)
20 AWG	424.33 feet (129.34 meters)
22 AWG	264.55 feet (80.63 meters)
24 AWG	166.76 feet (50.83 meters)

Wiring Guidelines - TCR - 200 mA	
Wire size	Maximum wiring length
18 AWG	586.55 feet (178.78 meters)
20 AWG	371.29 feet (113.17 meters)
22 AWG	231.48 feet (70.56 meters)
24 AWG	145.91 feet (44.47 meters)

Preparing/connecting captive wires

1. Strip 0.25 inch of wire insulation off all wires.
2. Insert each wire into the appropriate opening on the connector according to the wiring diagrams and connector types described in this section.

Do not tighten the screws excessively; doing so may strip the threads and damage the connector.

TV Sensor connections

Connect the CC-IR to the TV Sensor connector, on the rear panel of the television controller, as shown in FIG. 2 to detect horizontal scan frequencies up to 65 kHz.

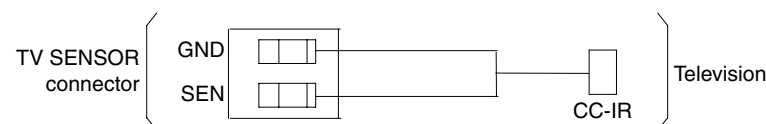

FIG. 2 CC-IR TV Sensor connector wiring diagram

IR Emitter connections

Connect the CC-IRC IR Emitter to the IR Emitter connector, on the rear panel of the television controller (FIG. 3) to transmit IR control signals to the television.

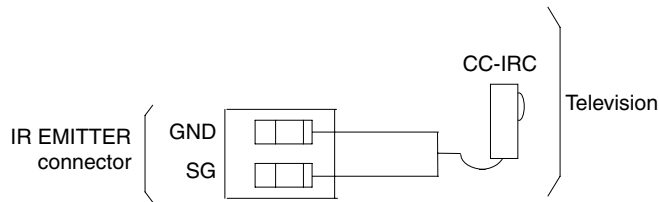

FIG. 3 CC-IRC IR Emitter connector wiring diagram

Axlink data and power connections

Connect the Central Controllers's AXlink connector to the AXlink connector on the rear panel of the television controller for data and 12 VDC power, as shown in FIG. 4.

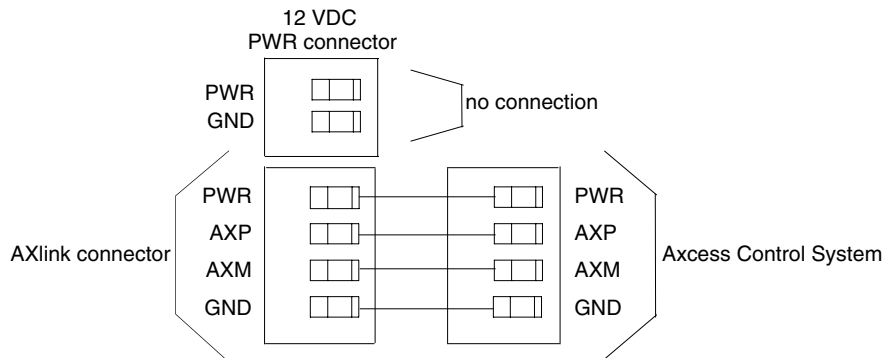

FIG. 4 AXlink data and power wiring diagram

Axlink data and 12 VDC power supply connections

Connect the Central Controller's AXlink connector to the AXlink connector on the rear panel of the television controller, and the optional 12 VDC power supply, as shown in FIG. 5.

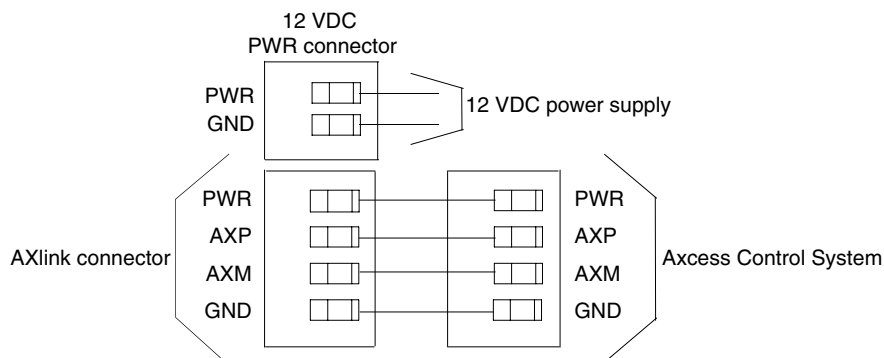

FIG. 5 AXlink Data and 12 VDC Power Supply Connections

Use the 12 VDC power supply when the distance between the AMX system and television controller exceeds the limits described in the Wiring Guidelines table on page 7.



Make sure to connect only the GND wire on the AXlink connector when using a 12 VDC power supply. Do not connect the PWR wire to the AXlink connector's PWR opening.

PCS and Axlink data and power connections

Connect the PCS Power Current Sensor to the TV Sensor connector, on the rear panel of the television controller (FIG. 6) to detect and control the television power status (on or off).

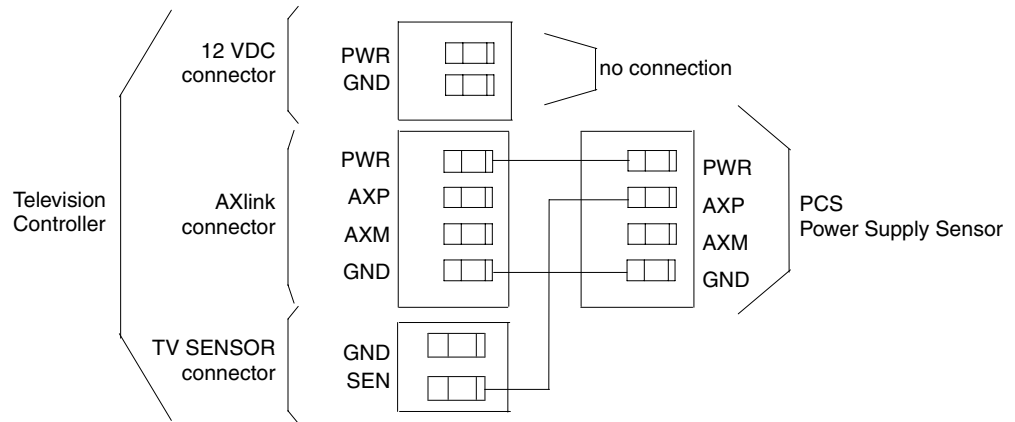

FIG. 6 PCS and AXlink data and power wiring diagram

PCS and 12 VDC power supply connections

Connect the PCS to the TV Sensor connector, on the rear panel of the television controller, and the optional 12 VDC power supply, as shown in FIG. 7, to detect and control the television power status (on or off).

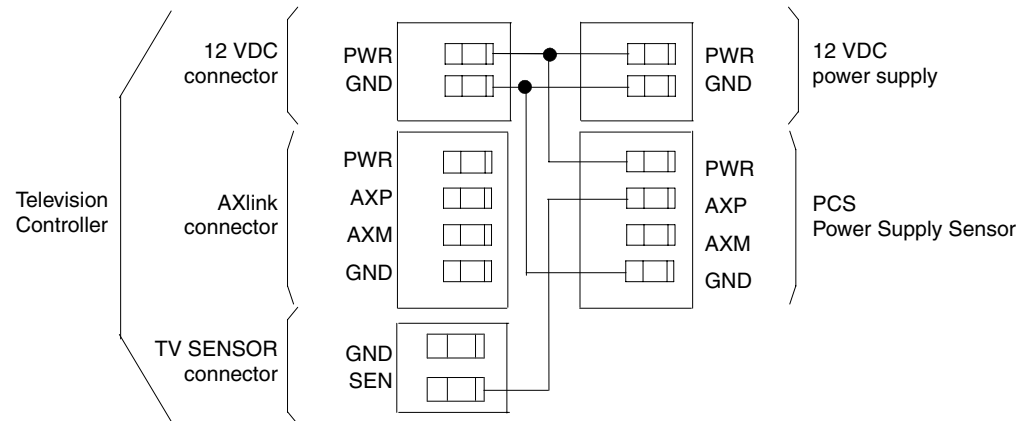

FIG. 7 PCS and optional 12 VDC power supply wiring diagram

Installation

Install the television controller on any flat surface or inside the optional SE-TC Security Enclosure, as described below:

1. Mount the Access Central Controller where it will be used. Then, connect the power supply.
2. Route the Axlink power and data cable, CC-IR TV Sensor cable, CC-IRC IR Emitter cable, and 12 VDC power supply from the television to the television controller's location.
3. Drill four #6-32 holes into the SE-TC mounting surface in the locations shown in FIG. 8.

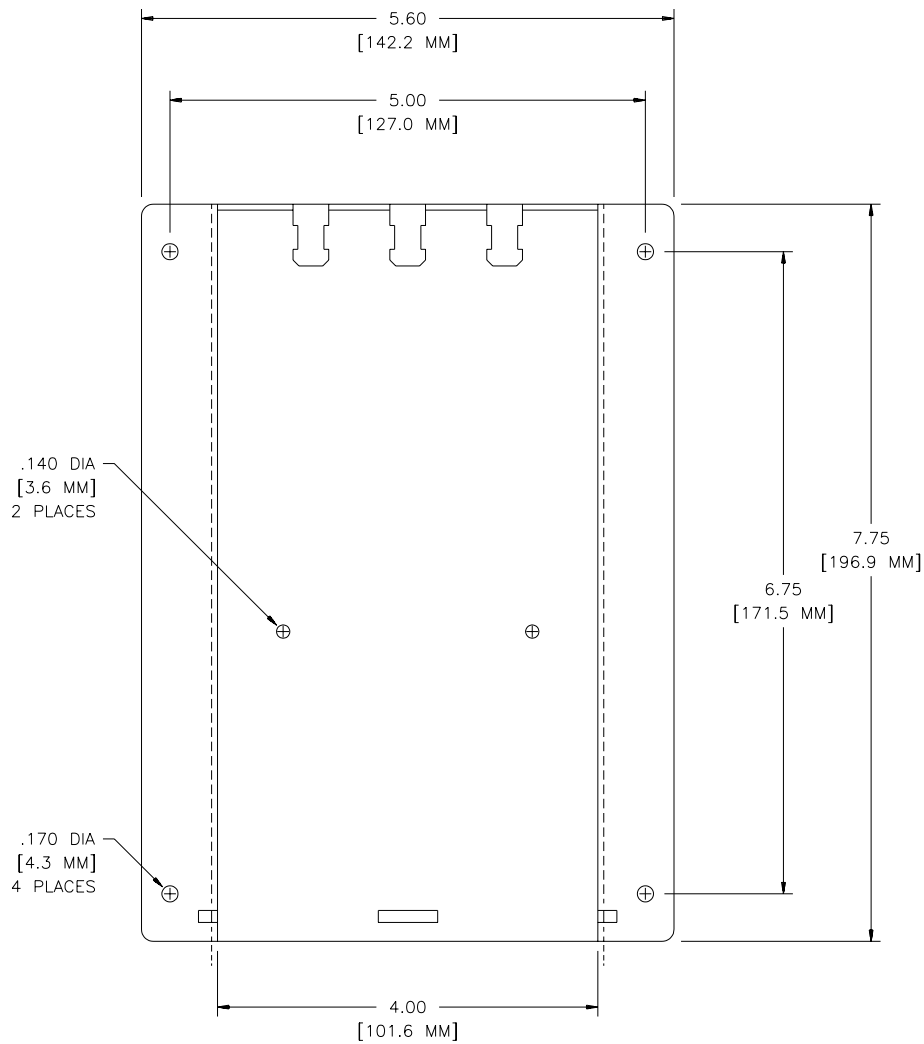

FIG. 8 SE-TC mounting dimensions

4. Mount the SE-TC.

Television Power Sensor Adjustment

After connecting the CC-IR to the television, the power sensing POT, on the rear of the television controller (see FIG. 1 on page 1), may require adjustment to detect the television's power status:

Use a Phillips-head screwdriver and flat-blade tool (non-conducting) to adjust the POT screw.

1. Turn the television off.
2. Locate the POT screw on the circuit card and turn it clockwise 20 full turns or until it clicks. The red TV Sensor indicator, located on the front panel, should be dark.
3. Turn the television on.
4. Turn the POT screw counterclockwise until the TV Sensor indicator lights. Then, turn the POT screw counterclockwise one full turn.
5. Turn television power off. If the TV Sensor indicator is lit, turn the POT screw clockwise until the indicator goes dark.
6. Reattach the enclosure and refasten the two screws.

IR Signal Attenuation Adjustment

If you experience television control problems after connecting a CC-IRC IR Emitter to the television, the television may be too sensitive to interpret the IR signals generated by the television controller. You can use the IR signal attenuation POT, located inside the television controller (FIG. 9), to decrease the strength of the IR signal.

Refer to *Internal Jumper Settings* section on page 5 to put the AXB-TC or AXB-TCR in IR attenuation mode.

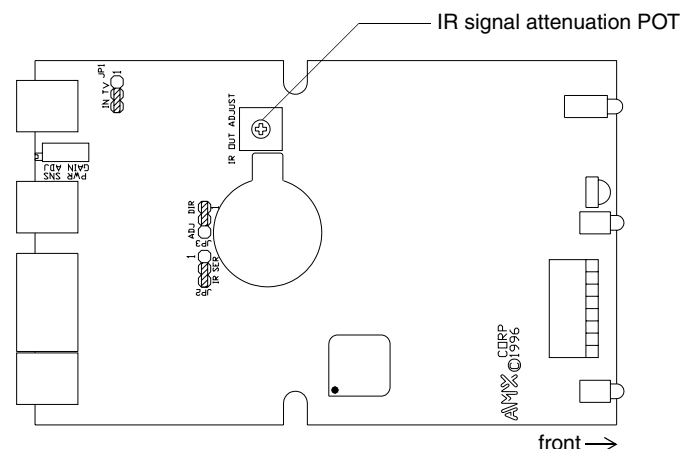

FIG. 9 IR signal attenuation POT location

Use a Phillips-head screwdriver and flat-blade tool (non-conducting) to adjust the POT screw.



Static electricity can damage electronic circuitry. Discharge any static electricity from your body by touching a grounded metal object before adjusting the POT.

1. Remove the two Phillips-head screws on the bottom of the television controller enclosure.
2. Pull the two enclosure halves apart and set the bottom portion of the enclosure on a flat surface.
3. Locate the POT screw on the circuit card and turn it counterclockwise with a flat-blade tool until it stops.

4. Turn the POT screw clockwise one-eighth turn to increase signal saturation. Then, send an IR control signal to the television. If the television performs correctly, go to step 5. If not, repeat this step until the television performs the correct operation.
5. Send an IR control signal to the television for all programmed operations. If an operation fails, go back to step 4.
6. Reattach the enclosure and refasten the two screws.

Replacing the Lithium Battery

There is a lithium battery (FIG. 10), with a life of approximately five years, in the television controller that protects stored presets if there is a power loss. The battery is not used when DC power is supplied to the television controller. You should write down the replacement date on a sticker or label by adding 5 years to the date of installation, and attach it to the bottom of the television controller.

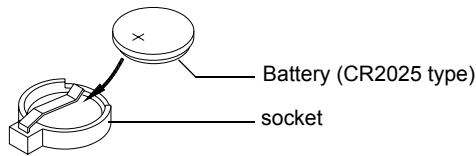

FIG. 10 Lithium battery and socket



CAUTION

All control commands in television controller memory are lost when the lithium battery is replaced.

Contact your AMX dealer before you replace the lithium battery to verify that they have a current copy of the IRLIB program file for your television controller. This will prevent any inadvertent loss of data or service outage.



CAUTION

Static electricity can damage electronic circuitry. Before removing the battery from the enclosure, discharge any static electricity from your body by touching a grounded metal object.

Use a flat-blade tool (non-conducting) that can be slipped under the lithium battery to pry it up and out of the socket.

1. Discharge the static electricity from your body.
2. Unplug all cables from the television controller.
3. Remove the two Phillips-head screws on the bottom of the television controller enclosure.
4. Pull the two enclosure halves apart and set the bottom portion of the enclosure on a flat surface.
5. Locate the battery on the circuit card.
6. Carefully pry the battery out of its socket and insert the new battery. Write down the next replacement date on a label by adding 5 years to the replacement date; attach it to the bottom of the television controller.
7. Reattach the enclosure and refasten the two screws.
8. Plug all cables back into the television controllers.



There is a danger of explosion if you replace the battery incorrectly. Replace the battery with the same or equivalent type, recommended by the manufacturer. Dispose of the used battery according to the manufacturer's instructions. Never recharge, disassemble, or heat the battery above 212 °F (100 °C). Never solder directly to the battery or expose the contents of the battery to water.

Programming Information

Overview

The television controllers are controlled with channel settings, IR functions, and Axxess Send_Commands. You create software programs with the AMX Axxess programming software. Use the programming information in this section with the *Axxess Programming Guide* to program television controllers. After you create the IRLIB program, download it to the non-volatile (battery protected) memory in the television controller. Refer to the *IRLIB Infrared Library Management Program* instruction manual to create and store IR control files.

Channel Setting Commands

Use the channel setting commands listed in the following table to generate IR code, PUSH and RELEASE operations, and to detect power failure errors.

Channel Setting Commands	
Channel	Description
1-127	Channels that generate IR code for the corresponding functions.
128-247	PUSH and RELEASE channels for received IR code.
248	A PUSH on this channel generates a power failure error.
249	Red IR sensor (AXB-TCR only) LED blinks when channel 249 and 250 are on.
250	Red IR sensor (AXB-TCR only) LED lights when channel is on.
255	Channel is on, when the television power sensor (CC-IR) detects a horizontal scan frequency. The channel is disabled after the television controller receives a 'POF' (power off) or 'PON' (power on) command. The channel is enabled after the television controller receives a 'POD' (disable 'PON' or 'POF') command.



NOTE

If one of these channels is turned on while another is already on, the initial channel stops transmitting and the second channel begins.

IR Functions (Standard Order)

The following table lists the IR function, in their standard order.

IR Functions (Standard Order)			
Function	Description	Function	Description
1	play >	22	channel up or +
2	stop []	23	channel down or -
3	pause or still	24	volume up or +
4	ffwd >>	25	volume down or -
5	rewind <<	26	mute
6	search fwd >> (AMS music search fwd for CD)	27	on (power typically)
7	search rev << (AMS music search rev for CD)	28	off (power typically)
8	record	29	TV/Video, TV/VCR, or TV/LDP (one button source selection)
9	power or on/off	30	TV
10	'0 ' or '10 '	31	Video1, Line A, VCR1, VDP, or input +
11	'1 ' (channel digits or tracks for CD)	32	Video2, Line B, VCR2, or input -
12	'2 '	33	Video3
13	'3 '	34	RGB1 or Tape1
14	'4 '	35	RGB2 or Tape2
15	'5 '	36	CD
16	'6 '	37	tuner
17	'7 '	38	phono
18	'8 '	39	aux
19	'9 '	40	AM/FM
20	'+10 ' (for CD players typically)	41	play < (play reverse)
21	enter (typically used in conjunction with numbers)	42	A/B

Send_Commands

Use the Send_Commands listed in the following table to program the Axxess Central Controller and television controller.

- The device number range for the television controller is 1 through 255.
- Refer to the *Axxess Programming Language* instruction manual for additional programming information.

Send_Commands	
CARON	<p>Enables an IR carrier signal after receiving a 'CARON' command.</p> <p>Example:</p> <pre>SEND_COMMAND 1, 'CARON'</pre> <p>Enables the carrier signal for device 1.</p>
CAROFF	<p>Disables an IR carrier signal from responding until a 'CARON' command is received. Use this command to control television controllers via serial communication.</p> <p>Example:</p> <pre>SEND_COMMAND 255, 'CAROFF'</pre> <p>Disables the carrier signal for device 255.</p>
'CH',<Channel>	<p>Generates IR digit pulses to select a television channel number. Channels 1-99 pulse as two digits. Channels 100 and greater, the one-hundredth digit pulses as 127. If IR function 21 (enter) exists, it follows the IR digit pulses.</p> <p>Variable:</p> <p><Channel> = 0-199</p> <p>Example:</p> <pre>SEND_COMMAND 2, "'CH', 25"</pre> <p>Sets the television connected to device 2 to channel 25.</p>
'CTOF',<Time>	<p>Sets the single IR pulses off time between channel digits and IR functions. Time is stored in permanent memory. The channel digit off time is set with the 'CH' command and the single pulse off time is set with the 'SP' command.</p> <p>Variable:</p> <p><Time> = 0-255; default = 5 (0.5 seconds)</p> <p>Example:</p> <pre>SEND_COMMAND 3, "'CTOF', 10"</pre> <p>Sets the off-time pulse time (delay) to 1 second for device 3.</p>
?CTOF	<p>Sends the current off-time pulse string "'CTOF',<Time>" to the master. Set the <Time> value in .10 second increments.</p> <p>Example:</p> <pre>SEND_COMMAND 35, '?CTOF'</pre> <p>Sends the current off-time pulse string from device 35 to the master.</p>
'CTON',<Time>	<p>Sets the IR pulse (single) on-time between channel digits and IR functions. Time is stored in permanent memory. System default is 5 (.5 second). The channel digit on time is set with the 'CH' command and the single pulse on time is set with the 'SP' command.</p> <p>Variable:</p> <p><Time> = 0-255; default = 5 (0.5 seconds)</p> <p>Example:</p> <pre>SEND_COMMAND 92, "'CTON', 20"</pre> <p>Sets the on-time pulse (delay) to 2 seconds for device 92.</p>

Send_Commands (Cont.)	
?CTON	<p>Sends the current on-time pulse string "'CTON',<Time>" to the master. Set the <Time> value in .10 second increments.</p> <p>Example:</p> <pre>SEND_COMMAND 92, '?CTON'</pre> <p>Sends the current on-time pulse string from device 92 to the master.</p>
'DC',<IR in>,<IR out>	<p>Sets a direct connection so the <IR out> (IR function) data transmits while the <IR in> code is received. The PUSH and RELEASE for the <IR in> code is not sent to the master. The maximum number of direct connections is 16.</p> <p>Variables:</p> <p><IR in> = Custom IR function assigned to hand-held IR transmitting device</p> <p><IR out> = IR functions (see the IR Functions (Standard Order) table on page 16)</p> <p>Example:</p> <pre>SEND_COMMAND 26, "'DC',145,24"</pre> <p>Increases the volume level on the equipment connected to device 26.</p>
'DE',<Time>	<p>Sets the delay time in .10 second increments for the TV sensor (CC-IR) to stabilize before sensing for a status change.</p> <p>Variable:</p> <p><Time> = 0-255; System default time = 10 (1 second).</p> <p>Example:</p> <pre>SEND_COMMAND 25, "'DE',10"</pre> <p>Sets the delay time to 1 second for the CC-IR connected to device 25.</p>
?DE	<p>Sends the current television power sensor (CC-IR) delay time string "'DE',<Time>" to the master.</p> <p>Set the <Time> value in .10 second increments.</p> <p>Example:</p> <pre>SEND_COMMAND 25, '?DE'</pre> <p>Device 25 sends the current television power sensor delay time to the master.</p>
DK	Deletes all direct connections set with the 'DC' command.
POD	Disables current 'PON' (power on) or 'POF' (power off) command settings. Channel 255 changes are enabled.
POF	<p>Sends IR function 28 (if available) or 9 to turn device power off. After three attempts, if the CC-IR (TV sensor) still detects a power-on status, the television controller starts processing stored buffer commands.</p> <p>Then, if another IR function 28 or 9 fails to turn the television's power off, the television controller sends a PUSH and RELEASE to channel 248 and generates a power failure error. If the device is turned on manually, this command turns television power off unless the television controller receives a 'PON' (power on) or 'POD' (disable 'POF') command.</p>
PON	<p>Sends IR function 27 (if available) or 9 to turn device power on. After three attempts, if the TV sensor (CC-IR) still detects a power-off status, the television controller starts processing stored buffer commands.</p> <p>Then, if another IR function 27 or 9 fails to turn the television's power on, the television controller sends a PUSH and RELEASE to channel 248 and generates a power failure error. If the device is turned off manually, this command turns television power on unless the television controller receives a 'POF' (power off) or 'POD' (disable 'PON' command) command.</p>

Send_Commands (Cont.)	
'PTOF',<Time>	<p>Sets the IR power-off pulse time after a power-on pulse in increments of .10 seconds. Time is stored in permanent memory.</p> <p>Variable: <Time> = 0-255; System default = 15 (1.5 seconds).</p> <p>Example: SEND_COMMAND 55, " 'PTOF' , 15 "</p> <p>Sets the power-off pulse time after a power-on pulse to 1.5 seconds for device 55.</p>
?PTOF	<p>Sends the current IR power-off pulse time string "PTOF', <Time>" to the master. Set the <Time> value in .10 second increments.</p> <p>Example: SEND_COMMAND 55, ' ?PTOF '</p> <p>Sends the current IR power-off pulse time from device 55 to the master.</p>
'PTON',<Time>	<p>Sets the IR power-on pulse time in increments of .10 seconds. Time is stored in permanent memory.</p> <p>Variables: <Time> = 0-255; System default = 5 (.5 second).</p> <p>Example: SEND_COMMAND 233, " 'PTON' , 20 "</p> <p>Sets the IR power-on pulse time (delay) to 2 seconds for device 233.</p>
?PTON	<p>Sends the current IR power-on pulse time string "PTON', <Time>" to the master. Set the <Time> value in .10 second increments.</p> <p>Example: SEND_COMMAND 233, ' ?PTON '</p> <p>Sends the current IR power-on pulse time from device 233 to the master.</p>
'RO',<Offset>	<p>Sets the offset value subtracted from the IR function before sending the code to the master.</p> <p>Variables: <Offset> = 0-255</p> <p>Example: SEND_COMMAND 62, " 'RO' , 5 "</p> <p>Subtracts 5 from the incoming IR code number and sends the appropriate IR function from device 62 to the master.</p>
'SP',<IR out>	<p>Generates a single <IR out> function pulse. The 'CTON' (pulse on) and 'CTOF' (pulse off) commands set the pulse time.</p> <p>Variable: <IR out> = 1-127 (see the IR Functions (Standard Order) table on page 16)</p> <p>Example: SEND_COMMAND 225, " 'SP' , 25 "</p> <p>Decreases the volume level on the equipment connected to device 255.</p>

Send_Commands (Cont.)	
<p>XCHM Changes the IR output pattern for the XCH command.</p>	<p>Syntax: SEND_COMMAND <DEV>, 'XCH-<Mode>'</p> <p>Variable: Mode = 0-4</p> <p>Example: SEND_COMMAND IR_1, 'XCH 3'</p> <p>Sets the IR_1 device's extended channel command to mode 3.</p> <p>Mode 0 Example (default): [x] [x] <x> <enter> SEND_COMMAND IR_1, 'XCH 3'</p> <p>Transmits the IR code as 3-enter. SEND_COMMAND IR_1, 'XCH 34'</p> <p>Transmits the IR code as 3-4-enter. SEND_COMMAND IR_1, 'XCH 343'</p> <p>Transmits the IR code as 3-4-3-enter. Mode 1 Example: <x> <x> <x> <enter> SEND_COMMAND IR_1, 'XCH 3'</p> <p>Transmits the IR code as 0-0-3-enter. SEND_COMMAND IR_1, 'XCH 34'</p> <p>Transmits the IR code as 0-3-4-enter. SEND_COMMAND IR_1, 'XCH 343'</p> <p>Transmits the IR code as 3-4-3-enter. Mode 2 Example: <x> <x> <x> SEND_COMMAND IR_1, 'XCH 3'</p> <p>Transmits the IR code as 0-0-3. SEND_COMMAND IR_1, 'XCH 34'</p> <p>Transmits the IR code as 0-3-4. SEND_COMMAND IR_1, 'XCH 343'</p> <p>Transmits the IR code as 3-4-3. Mode 3 Example: [[100][100]...] <x> <x> SEND_COMMAND IR_1, 'XCH 3'</p> <p>Transmits the IR code as 0-3. SEND_COMMAND IR_1, 'XCH 34'</p> <p>Transmits the IR code as 3-4. SEND_COMMAND IR_1, 'XCH 343'</p> <p>Transmits the IR code as 100-100-100-4-3.</p>
<p>XCH <Channel></p>	<p>Transmit the IR code in the format set with the XCHM mode command.</p> <p>Syntax: SEND_COMMAND <DEV>, 'XCH <Channel>'</p> <p>Variable: <Channel> = 0 through 999</p>

Firmware Upgrades

Firmware upgrades allow you to install the latest available operating system for your AXB-TC or AXB-TCR. The firmware reload is required anytime the unit's LEDs all flash at the same rate as the AXlink LED, or if all LEDs are full-on.

To accomplish the upgrade, your computer must be connected to the Access Master Controller via a serial (RS-232) interface connecting to the AXlink DB-9 programming port input.

There are two ways to upgrade the firmware to an Access device: via the DOS-based SOFTROM application, or via the NetLinx Studio program. Both are included on the AMX Software Control Disc.

Using SOFTROM

To be able to download new firmware, the communications settings must be set by following the steps below.

1. Press F1 and the CONFIGURE BAUD RATE window appears (FIG. 1).

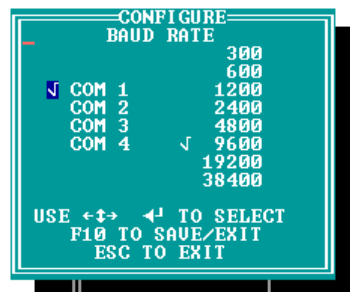

FIG. 1 CONFIGURE BAUD RATE window

2. Using the up/down arrow keys, select the communications port you are using to interface with the Central Controller and press Enter.
3. Using the right arrow key, move to the BAUD RATE column. Then use the up/down arrow keys to select the interface communications speed. Make sure that the BAUD RATE selections match the settings on the Access System Master Controller.
4. Press Enter.
5. Press F10 to save the selected setting and to exit the CONFIGURE screen.

After establishing the communications configuration, upgrade firmware as follows:

1. Press F5 to acquire the list of online programmable devices.
2. Using the up/down arrow keys, select your firmware version(s) listed in the Firmware column of the screen and press Enter.
3. Using the Tab key, switch to the ONLINE PANELS list.
4. Using the up/down arrow keys, select the device(s) to be programmed. Press Enter for each device as it is selected.



NOTE

F2 can be pressed to select all ONLINE PANEL devices and F3 can be pressed to clear all devices.

5. Press F4 to program the selected device(s), the loading status bar in FIG. 2 then appears.
6. Press F5 to refresh the screen. Verify that all selected panels have the correct firmware version. If any devices still indicated the old version, repeat preceding steps 3 through 5 until all panels indicate the correct firmware version.

- Upon completion of the upgrade, press F10 to exit SOFTROM.

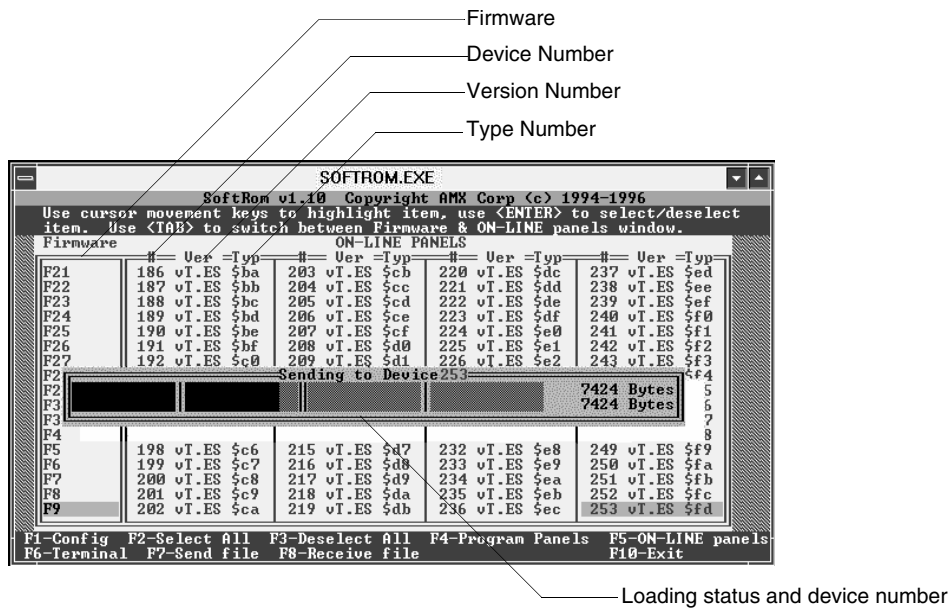

FIG. 2 Loading status bar

Firmware can be downloaded to multiple device numbers automatically. If multiple devices are selected, the bottom half of the loading bar will indicate the percentage complete for the selected devices.

Using NetLinX Studio

You can perform firmware upgrades for both Access and NetLinX devices using the options in the Firmware sub-menu.

Access Master Controllers use .TSK files for firmware upgrades.

- Choose **Tools > Firmware > Access Firmware** to open the Access Firmware Download dialog.
- Adjust the Comm Settings, if necessary:
 - Click **Settings** to open the Communication Setting dialog.
 - Select the **Communications Port** to use.
 - Click **OK** to accept the changes and return to the Access Firmware Download dialog.
- Click **Browse** to navigate to the directory containing the firmware file(s). Once a directory containing one or more .TSK files is specified, a list of available .TSK files is displayed in the upper table in this dialog.
- Select the desired .TSK file from the list.
- Click **Query Online Devices** to populate the on-line device list.
- Select the target AXlink device from the list of online devices in the lower table.
- Click **Download** to open the Confirm Communication Settings dialog, where you can review and confirm your Comm Settings and Target Device information before the download begins.
 - Click **Cancel** to return to the Select Access Firmware File dialog, to edit these settings (if necessary).
 - Click **OK** to confirm the Comm Settings and Target Device information, and download the selected .TSK file to the specified Master, on the selected communications port.
- The File Transfer dialog shows the progress of the download. Click **Cancel** to cancel the download.

9. Once the .TSK file has been downloaded, the program prompts you to reboot the Access Master. Click **Yes** to reboot, and the program initiates the reboot sequence. When the Master has rebooted, the Status LED on the front panel of the Master blinks once a second to indicate it is functioning properly.
10. Once it has rebooted, click **OK**.



It's Your World - Take Control™