

# Installation for 4-1/2 in. (114 mm) dial Temperature MURPHYGAGE® and SWICHGAGE®

**Model Series: SPLG, SPLC, SPLBP, 45TE and 45TEBP**  
**Options: -OS and -ES**



Please read the following instructions before installing. A visual inspection is recommended before mounting. General Information and these installation instructions are intended for all 4-1/2 in. (114 mm) dial temperature models.

## GENERAL INFORMATION

WARNING

BEFORE BEGINNING INSTALLATION OF THIS MURPHY PRODUCT

- ✓ Disconnect all electrical power to the machine.
- ✓ Make sure the machine cannot operate during installation.
- ✓ Follow all safety warnings of the machine manufacturer.
- ✓ Read and follow all installation instructions.



**SPLC and SPLFC SWICHGAGE®** instruments have high and low limit contacts to monitor, alarm or shutdown. The SPLC has a flanged case. SPLFC has a flush mount case intended for installation within a panel. A method to override the low limit contact for startup is provided on most models (see Operation Test Instructions on page 3).

**45TE and 45TEF Series** are versions of the SPL Series with 2-snap acting SPDT switches instead of the pointer type contacts. The 45TE Series does not include low contact lockout.

**SPLBP and 45TEBP** models are designed to start and stop electric motor driven equipment. The pilot duty contacts are connected to a latching control relay for automatic ON/OFF control, either directly or through a motor starter.

### Options -OS and -ES

The -OS (oil sealed case) and the -ES (environment sealed case) options for corrosive environment feature flush mount case design to be installed within a panel.

### Precautions

- Do NOT exceed rated temperature range.
- Use shock mounts as necessary to protect from vibration.
- Cutting or sharp bending the capillary will cause permanent damage to the SWICHGAGE® and will void the warranty.
- Excess capillary should be carefully coiled and secured away from damage.
- Do not route capillary along exhaust manifold.
- Avoid routing capillary at level higher than gage mounting.

### Specifications

**Dial:** White on black, dual scale, °F and °C standard, 4-1/2 in. (114 mm) diameter.

**Case:** Die cast aluminum, surface or panel mount.

**Capillary:** PVC armored copper tube, 5 ft. (1.5 m) long standard.

**Sensing Bulb:** Copper bulb std.: 1/2 in. (13 mm) OD; Length 7 in. (178 mm). Pressure rating: 600 psi (4.1 MPa) [41 bar]. Connection: 1/2 NPTM compression fitting.

**NOTE:** Use of thermowell is highly recommended.

**Switch Reset Deadband:** Approximately 10% FS.

**Snap-Acting Switches:** See wiring information (page 4).

**Dry Relay Contact ("BP" Models):** 10 A @ 28 VDC or 10 A @ 120 VAC.

**Wire Connections (Surface Mount):** 1/2 NPTF conduit/terminal block.

**Wire Connections (Panel Mount):** Wire leads, 18 AWG (1.0 mm<sup>2</sup>) x 9 in. (229 mm) long.

**Wire Connections (-ES, -OS, -CC):** 1/2 NPTM conduit and wire leads, 24 AWG (0.22 mm<sup>2</sup>) x 33 in. (838 mm) long.

**Overrange:** Do not exceed 10% FS above full range.

**Item Weight:** 8 lbs (3.6 kg) approx. Explosion-proof models: 22 lb. (10 kg) approx.

**Item Dimensions:** 16 x 11 x 5-1/2 in. (406 x 279 x 140 mm) approximately. Explosion-proof: 12 x 12 x 9 in. (305 x 305 x 229 mm) approximately.

### Accuracy

Temperature Range	Lower 1/4	Middle 1/2	Upper 1/4
15 to 250°F (9 to 121°C)	± 8°F (± 4°C)	± 2°F (± 1°C)	± 2°F (± 1°C)
130 to 350°F (54 to 177°C)	± 8°F (± 4°C)	± 2°F (± 1°C)	± 3°F (± 1.5°C)
260 to 450°F (127 to 232°C)	± 8°F (± 4°C)	± 2°F (± 1°C)	± 3°F (± 1.5°C)

\*Selected configurations are CSA approved. Consult factory for details.

\*\*Products covered by this literature comply with EMC Council directive 89/336/EEC regarding electromagnetic compatibility as noted. Does not cover "BP" models.

# CASE MOUNTING

## Wall Mount

Flanged case design intended for wall mount. Shown with shock mounts (optional).

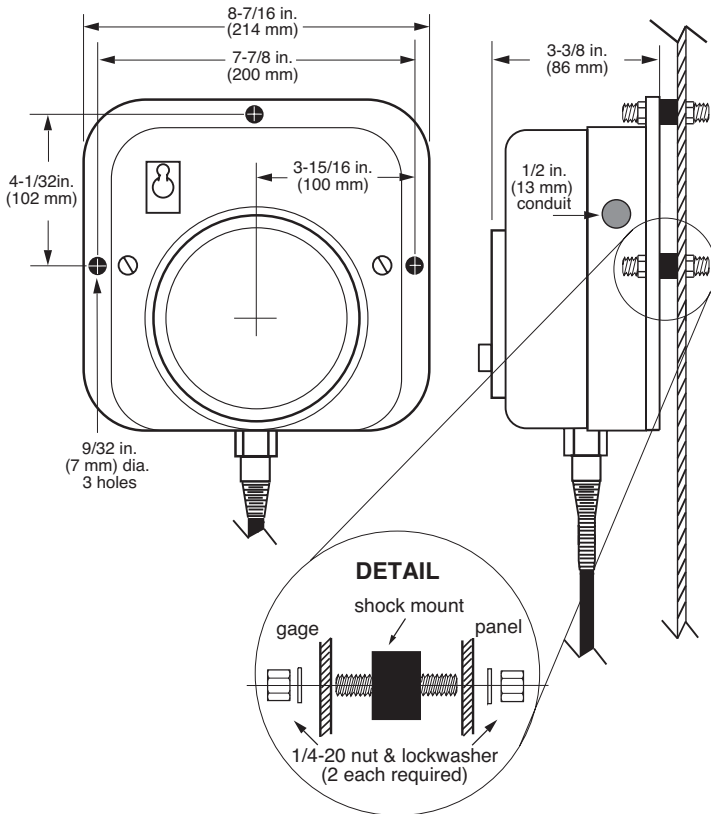

## Flush Mount

A round case design to be mounted within a panel from 1/32 in. (1 mm) to 1/8 in. (3 mm) thick.

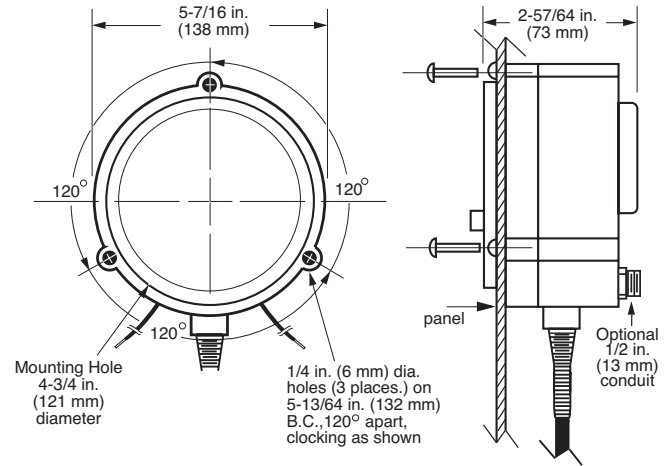

## Options -OS, -ES (flush mount case)

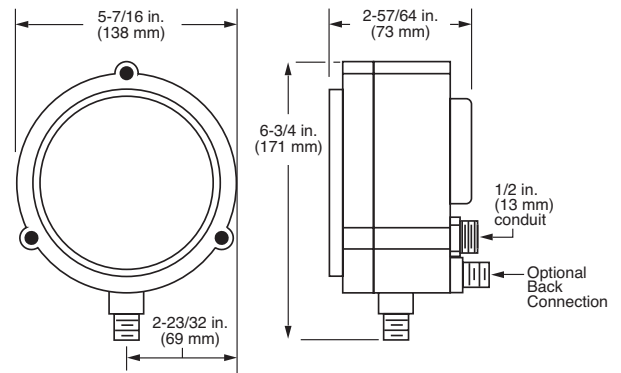

## Explosion-proof Case Mount

Explosion-proof case can be mounted from face or rear.

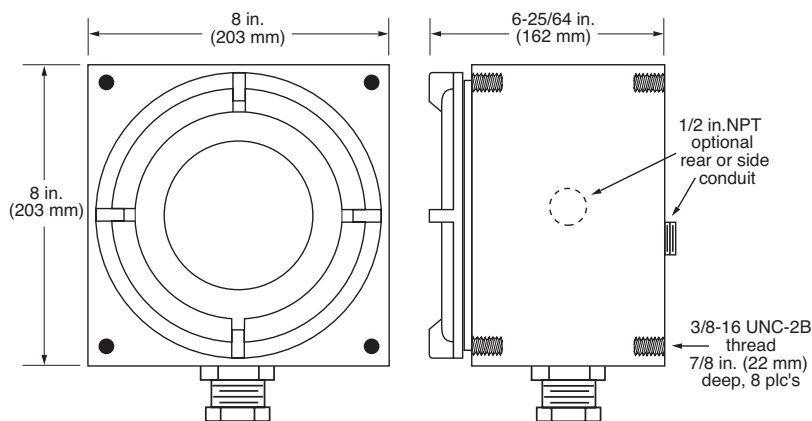

## Flush mount/Wall mount\*

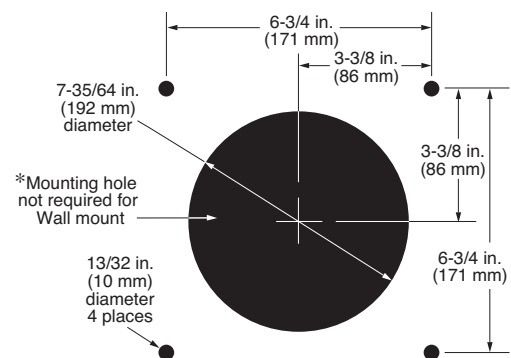

## SENSING BULB-THERMOWELL INSTALLATION

### Precautions

Cutting or sharp bending the capillary will cause permanent damage to the SWICHGAGE® and will void the warranty. Excess capillary should be carefully coiled and secured away from damage. Do not route capillary along exhaust manifold. Avoid routing capillary at a level higher than gage mounting.

### Installing Sensing Bulb

1. Install the 1/2 NPT adapter into the application.
2. Slip compression nut and ferrule onto bulb.
3. Insert the sensing bulb directly through the adapter and fully immerse it into the process without interference. Be sure to leave enough of the bulb to allow the compression nut and ferrule to be tightened.
4. Keep the bulbs active section in the middle of the process flow.
5. Tighten the compression nut and ferrule. This will keep the bulb in place and obtain a full seal.

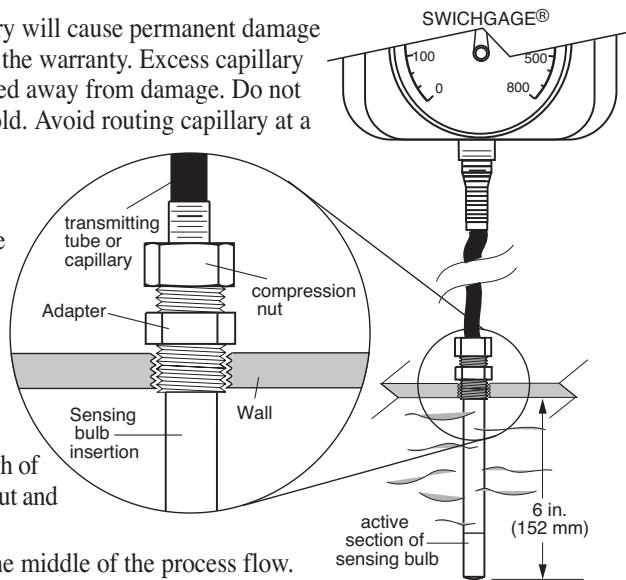

### Installing Thermowell

Thermowell is recommended for high pressure applications or corrosive environments. It also allows temperature sensor to be changed or adjusted without opening connection to process.

1. First screw the thermowell into the process (pipe line).
2. Pass the sensing bulb through the nut and ferrule.
3. Fully insert the sensing bulb into the thermowell housing and secure it with the compression nut.

**NOTE:** The use of temperature transmitter grease or silicon grease on the tip of the sensing bulb is recommended to facilitate heat transfer to sensing bulb junction.

## LIMIT CONTACTS / INDICATION POINTER ADJUSTMENTS

### Limit Contact Adjustments

Facing the dial, left side knob is "Low limit" contact. Right side is "High limit" contact.

**NOTE:** the 45TE Series features a stacked limit indicator knob with both limit adjustments included. The bottom half knob adjusts the "Low" limit indicator, the top half is to adjust the "High" limit indicator.

To set limit contact, turn the knob to the desired point on the scale.

### Limit Contact Wiping Feature (SPL)

The force of pointer causes the flexible contact arm (A) to "tilt" resulting in a wiping action (D). This clears away film or corrosion formed on the contact surfaces.

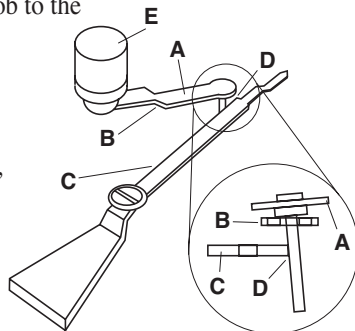

- A. Contact arm-flex
- B. Contact arm
- C. Pointer Contact
- D. Initial point of contact
- E. Limit contact knob

### Indication Pointer Adjustments

To reset to zero or to a known value proceed as follows:

1. Turn off power. Remove the snap ring and the lens/contact assembly (or open hinged cover).
2. Hold the pointer hub with thumb and forefinger then turn screw to desired point. Avoid touching the gold flashed, silver contact areas. See **DETAIL "A"**

For the 45TE Series see **DETAIL "B"**.

3. Replace lens contact assembly and snap ring (or close hinged cover), and turn on power.

**NOTE:** Span adjustments and recalibration must be performed by an authorized mechanic or return the unit to Frank W. Murphy Mfr.

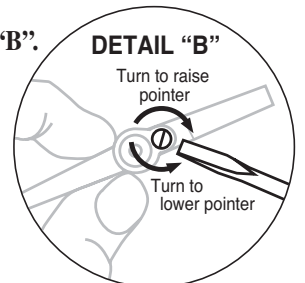
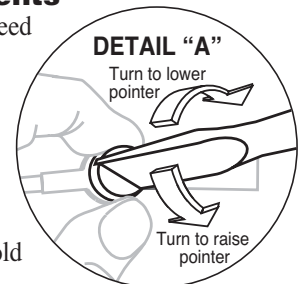

## OPERATION TEST INSTRUCTIONS

### SPLC and SPLFC Series

1. Perform operation test after the unit is installed and wired appropriately (see Typical Electrical Diagrams on page 4).
2. When temperature is applied to the sensing bulb the pointer will travel in a clockwise direction. (Adjust contacts to desired set points.)
3. Place the toggle switch (SPLC Series only) in the "start" position or otherwise override low contact. After the indication pointer rises past the low limit contact, return the toggle switch to the "run" position.
4. To test the limit contacts, turn the limit contact to be tested until it touches the pointer. That will trip the control circuit.
5. Reset the shutdown or alarm circuit device.

### 45TE Series

1. Perform steps 1 and 2 in the SPLC Operation Test Instructions.
2. To test the switches, turn the limit indicator until it touches the pointer, then continue to rotate until the snap-switch operates\*.
3. Reset the shutdown or alarm circuit device.

\*The trip point indicator will stop the pointer movement slightly before the snap-switch operates. As temperature continues to increase or decrease, the trip point setting is reached.

# TYPICAL ELECTRICAL DIAGRAMS



**WARNING:** Perform the wiring operation with the power source "OFF". Make sure the voltage and current requirements are within the SWICHGAGE® ratings. Before wiring determine voltage and polarity for the application. Use the appropriate wire size. All connections should be made using a spade (forked) or ring terminals. For pigtail connections use wire nuts. Conduit is recommended to protect wires from damage.

## SPLC and SPLFC

**Contact Ratings:** 1 SPDT, Center off; 2A, 30VDC, 1A, 125VAC pilot duty.

**NOTE:** Diagrams below show the pointer in the at rest (shelf) position.

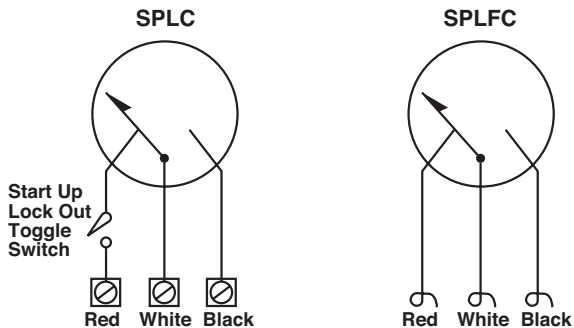

## SPLBP

**Contact Ratings:** SPDT dry relay contacts; 10 A, 125 VAC.

**NOTE:** Diagrams below show the pointer in the at rest (shelf) position.

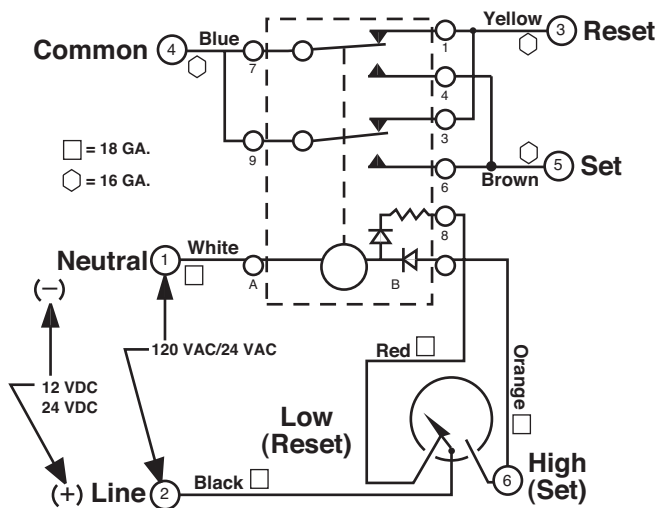

## Transformer Relay Assemblies

For higher voltages the Murphy TR Assemblies can be used in conjunction with any SWICHGAGE®.

## 45TE and 45TEF

**Contact Ratings:** 2-SPDT snap-switches (One for high and low temperature); 2 A inductive, 250 VAC each switch.

**NOTE:** Diagram below show the pointer in the at rest (shelf) position.

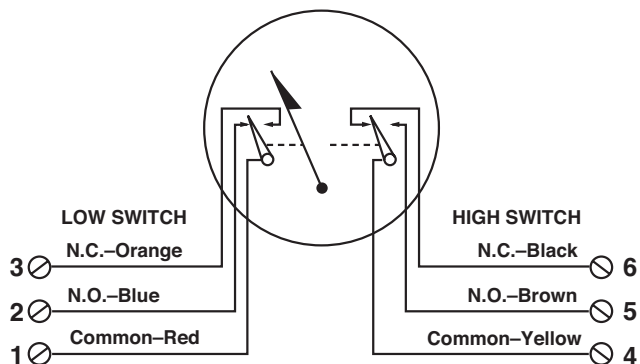

## 45TEBP

**Contact Ratings:** SPDT dry relay contacts; 10 A, 125 VAC.

**NOTE:** Diagrams below show the pointer in the at rest (shelf) position.

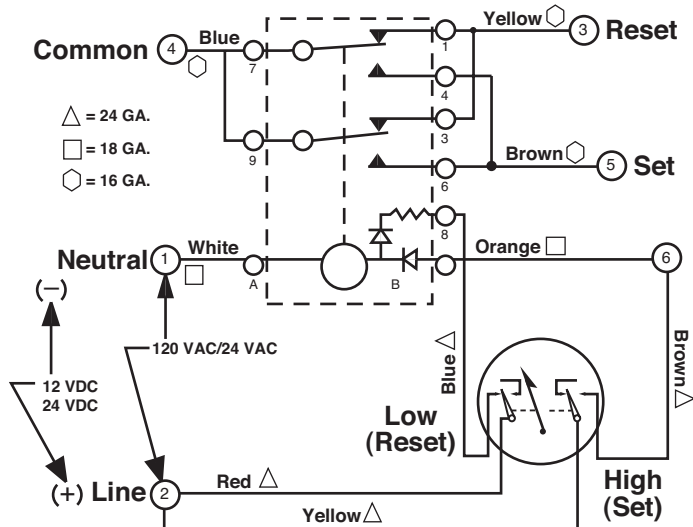

**FW Murphy**  
P.O. Box 470248  
Tulsa, Oklahoma 74147 USA  
+1 918 317 4100  
fax +1 918 317 4266  
e-mail sales@fwmurphy.com  
www.fwmurphy.com

**CONTROL SYSTEMS & SERVICES DIVISION**  
P.O. Box 1819; Rosenberg, Texas 77471; USA  
+1 281 633 4500 fax +1 281 633 4588  
e-mail sales@fwmurphy.com

**MURPHY DE MEXICO, S.A. DE C.V.**  
Blvd. Antonio Rocha Cordero 300, Fracción del Aguaje  
San Luis Potosí, S.L.P.; México 78384  
+52 444 8206264 fax +52 444 8206336  
Villahermosa Office +52 993 3162117  
e-mail ventas@murphymex.com.mx  
www.murphymex.com.mx

**FRANK W. MURPHY, LTD.**  
Church Rd.; Laverstock, Salisbury SP1 1QZ; U.K.  
+44 1722 410055 fax +44 1722 410088  
e-mail sales@fwmurphy.co.uk  
www.fwmurphy.co.uk

**MURPHY SWITCH OF CALIFORNIA**  
41343 12th Street West  
Palmdale, California 93551-1442; USA  
+1 661 272 4700 fax +1 661 947 7570  
e-mail sales@murphyswitch.com  
www.murphyswitch.com

**MACQUARRIE CORPORATION**  
1620 Hume Highway  
Campbellfield, Vic 3061; Australia  
+61 3 9358 5555 fax +61 3 9358 5558  
e-mail murphy@macquarrie.com.au



In order to consistently bring you the highest quality, full featured products, we reserve the right to change our specifications and designs at any time.

Printed in U.S.A.