

# Operation Manual

## High Speed Scanner

Model No. KV-SS25 / KV-SS25U / KV-SS25G

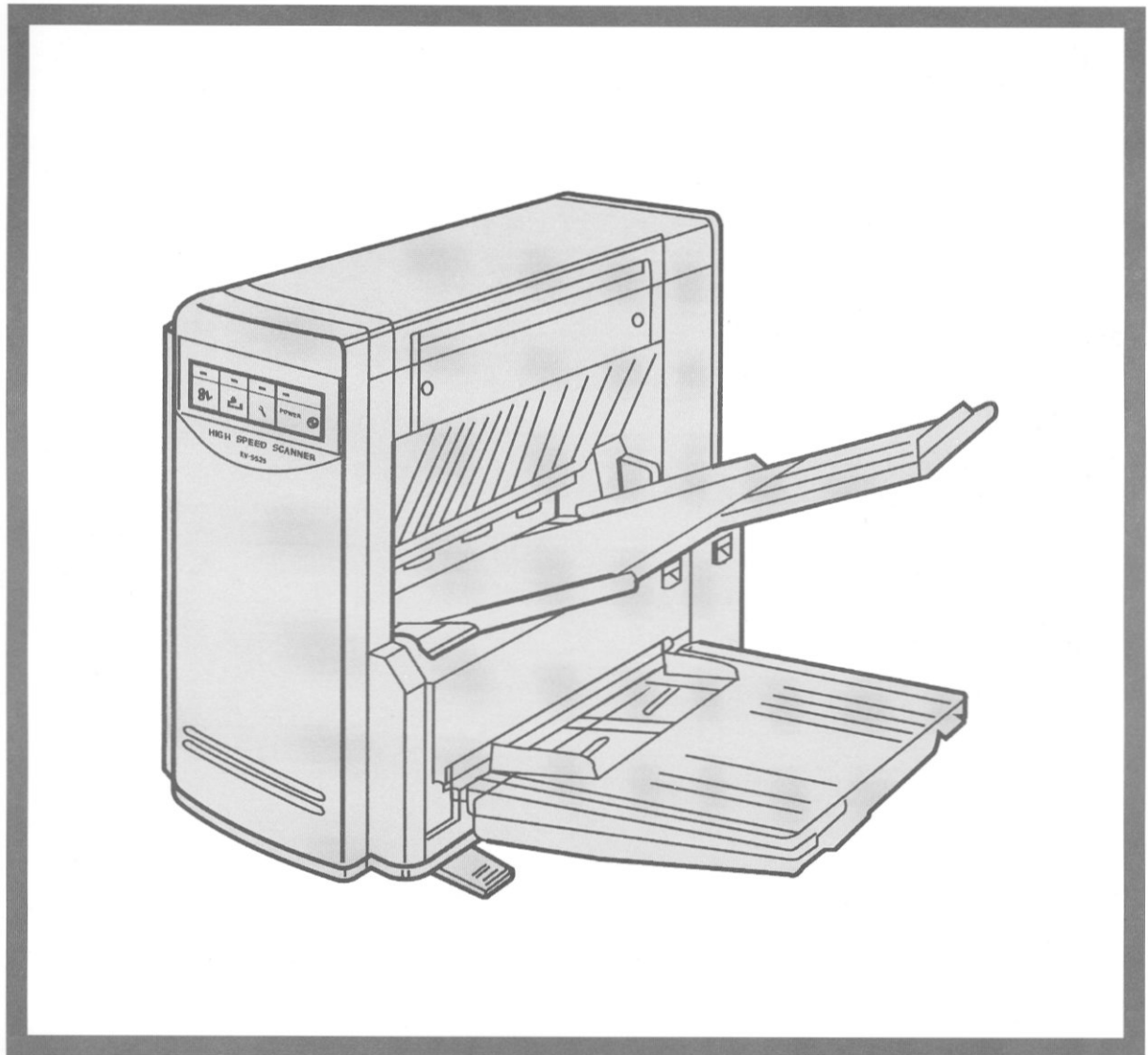

Before using this unit, please read these instructions completely.

**Thank you for purchasing a Panasonic "High Speed Scanner".**

## **Table of Contents**

Notice .....	3
Precautions .....	5
Component Identification .....	7
Minimum Space and Installing the Stand .....	8
● Minimum space .....	8
● Installing the stand .....	8
Installing the Document Tray and the Exit Tray .....	9
Loading a Document .....	10
Clearing Paper Jams .....	12
Cleaning the Unit .....	13
Repacking Instructions .....	15
Troubleshooting .....	16
Specifications .....	17
Index .....	18

The information given in this Operation Manual is subject to change without notice.  
This Operation Manual is printed on recycled paper.

# Notice

## Federal Communications Commission Requirements

(For United States only)

**Note:** This equipment has been tested and found to comply with the limits for a Class A digital device, pursuant to Part 15 of the FCC Rules. These limits are designed to provide reasonable protection against harmful interference when the equipment is operated in a commercial environment. This equipment generates, use, and can radiate radio frequency energy and, if not installed and used accordance with the instruction manual; may cause harmful interference to radio communications. Operation of this equipment in a residential area is likely to cause harmful interference in which case the user will be required to correct the interference at his own expense.

**FCC Warning:** To assure continued FCC compliance, the user must use only the provided power supply cord and shielded interface cable. Also, any unauthorized changes or modifications to this equipment would void the user's authority to operate this device.

### English

**WARNING:**

TO PREVENT FIRE OR SHOCK HAZARD, DO NOT EXPOSE THIS PRODUCT TO RAIN OR ANY TYPE OF MOISTURE.

THE SOCKET OUTLET MUST BE NEAR THIS EQUIPMENT AND MUST BE EASILY ACCESSIBLE.

### Français

**Avertissement:**

Pour éviter tout risque d'incendie ou de choc électrique, ne pas soumettre cet appareil à la pluie ou à l'humidité.

"La prise secteur devra se trouver à proximité de l'appareil et être facilement accessible."

### Deutsch

**Warnung:**

Zur Verhütung von Feuer dem und elektrischem Schlag dieses Erzeugnis nicht Regen oder sonstiger Feuchtigkeit aussetzen.

Die Steckdose muß nahe bei diesem Gerät angebracht und leicht zugänglich sein.

### Für Benutzer in der BRD



**Hinweis:**

Der arbeitsplatzbezogene Geräuschemissionswert dieses Gerätes beträgt  $\leq 70$  dB(A) nach DIN 45635 Teil 19.

## Notice

# For your safety please read the following text carefully.

(For United Kingdom only)

This appliance is supplied with a moulded three pin mains plug for your safety and convenience. A5 amp. fuse is fitted in this plug. Should the fuse need to be replaced please ensure that the replacement fuse has a rating of 5 amps. and that it is approved by ASTA or BSI to BS1362. Check for the ASTA mark  or the BSI mark  on the body of the fuse. If the plug contains a removable fuse cover you must ensure that it is refitted when the fuse is replaced. If you lose the fuse cover the plug must not be used until a replacement cover is obtained. A replacement fuse cover can be purchased from your local Panasonic Dealer.

If the fitted moulded plug is unsuitable for the socket outlet in your home then the fuse should be removed and the plug cut off and disposed of safely.

There is danger of severe electrical shock if the cut off plug is inserted into any 13 amp. socket.

If a new plug is to be fitted please observe the wiring code as shown below. If in any doubt please consult a qualified electrician.

**WARNING :** This appliance must be earthed.

**IMPORTANT :** The wires in this mains lead are coloured in accordance with the following code.

Green-and-Yellow	: Earth
Blue	: Neutral
Brown	: Live

As the colours of the wire in the mains lead of this appliance may not correspond with the coloured markings identifying the terminals in your plug, proceed as follows.

The wire which is coloured Green-and-Yellow must be connected to the terminal in the plug which is marked with the letter E or by the Earth symbol  $\perp$  or coloured Green-and-Yellow.

The wire which is coloured Blue must be connected to the terminal in the plug which is marked with the letter N or coloured Black.

The wire which is coloured Brown must be connected to the terminal in the plug which is marked with the letter L or coloured Red.

### How to replace the fuse :

Open the fuse compartment with a screwdriver and replace the fuse.

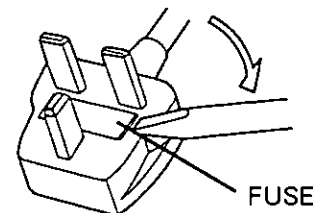

# Precautions

The following precautions are recommended to extend the life of the unit

Do not place any liquids near the unit  
– Accidental spillage of a liquid into the unit may cause severe damage. If this occurs, unplug the power cord and call service.

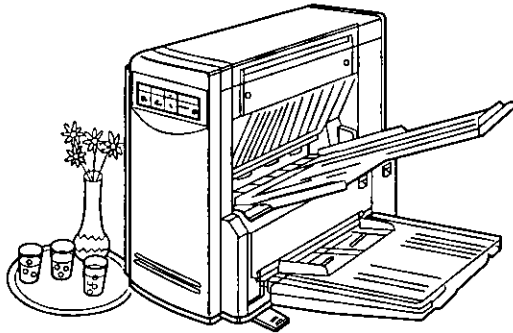

Do not place books, paper, or other items on the unit

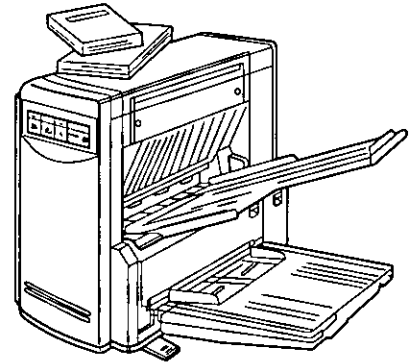

Do not operate the unit with covers open

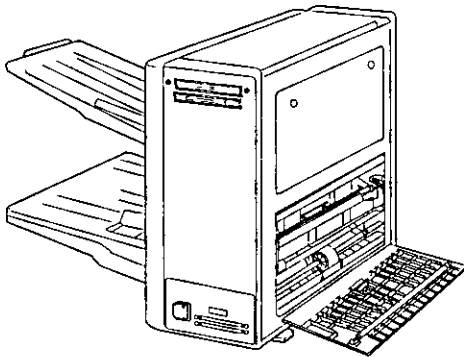

If the unit is not used for an extended period, unplug the power cord

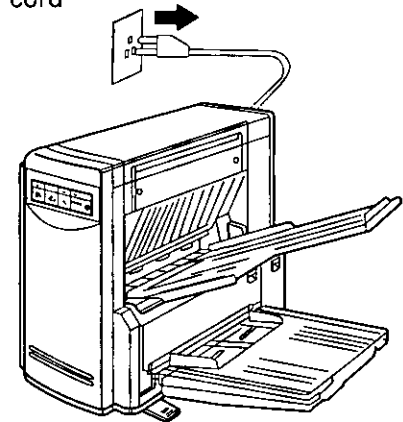

Do not place the unit on an uneven or unstable surface

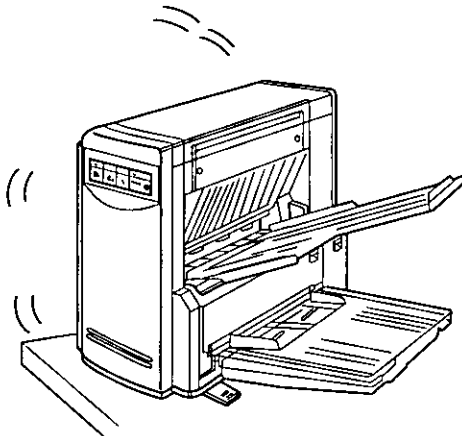

The unit must remain in a vertical position

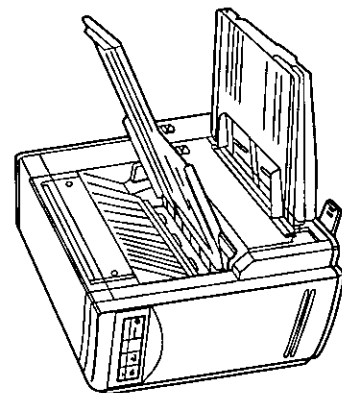

- Special care should be taken to protect the unit if it is used in a less than optimum environment such as a machine shop or a dusty or sandy area

# Precautions

## Operating Environment

Do not subject the unit the following conditions.

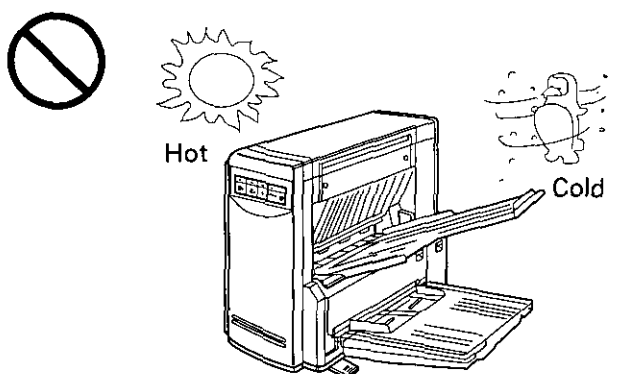
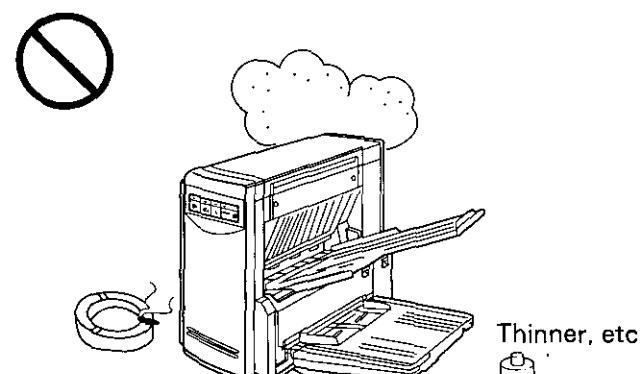
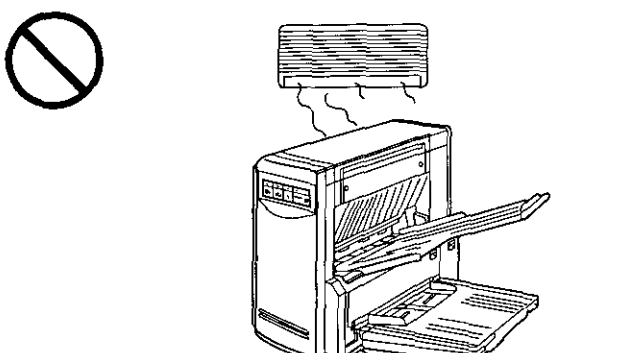
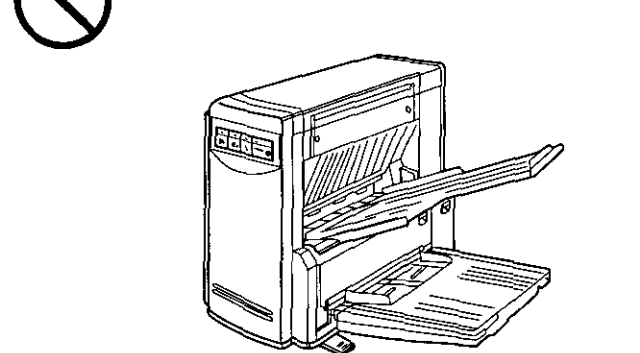
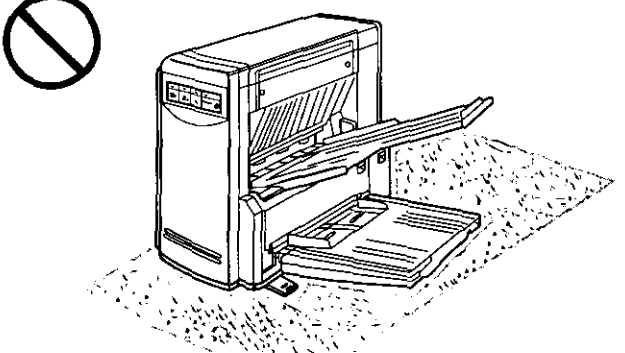
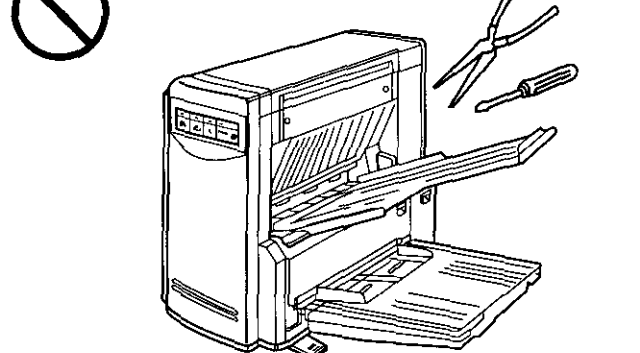
<p>Do not place the unit in direct sunlight or in a cold draft.</p>  <p>Hot Cold</p>	<p>Do not place the unit in an area where there is a lot of smoke, dust, chemical fumes or vibration.</p>  <p>Thinner, etc.</p>
<p>Do not place the unit near a heating appliance or an air conditioning vent. Do not place the unit in a room with extremely high or low humidity.</p> 	<p>Do not place the unit near other appliances.</p> 
<p>Do not place the unit on a carpet. (Static electricity can cause the unit to malfunction)</p> 	<p>Do not disassemble the unit.</p> 

### ● Power Source

- Use a voltage level which does not vary more than  $\pm 10\%$  from the voltage level marked on the nameplate (located on the rear of the scanner).
- Do not use an extension cord.
- This scanner should be connected to a grounded outlet.
- Do not use a line conditioner, transient suppressor or surge protector.

# Component Identification

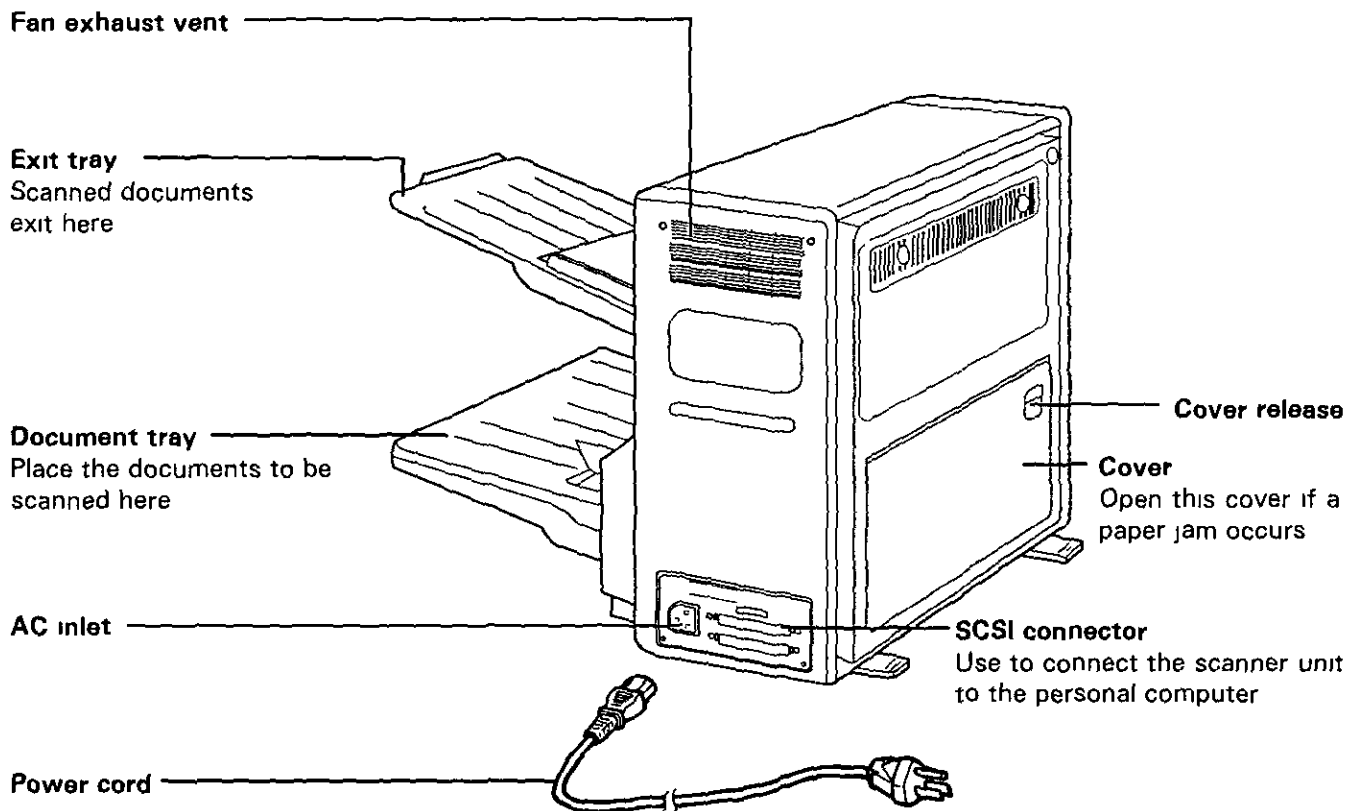
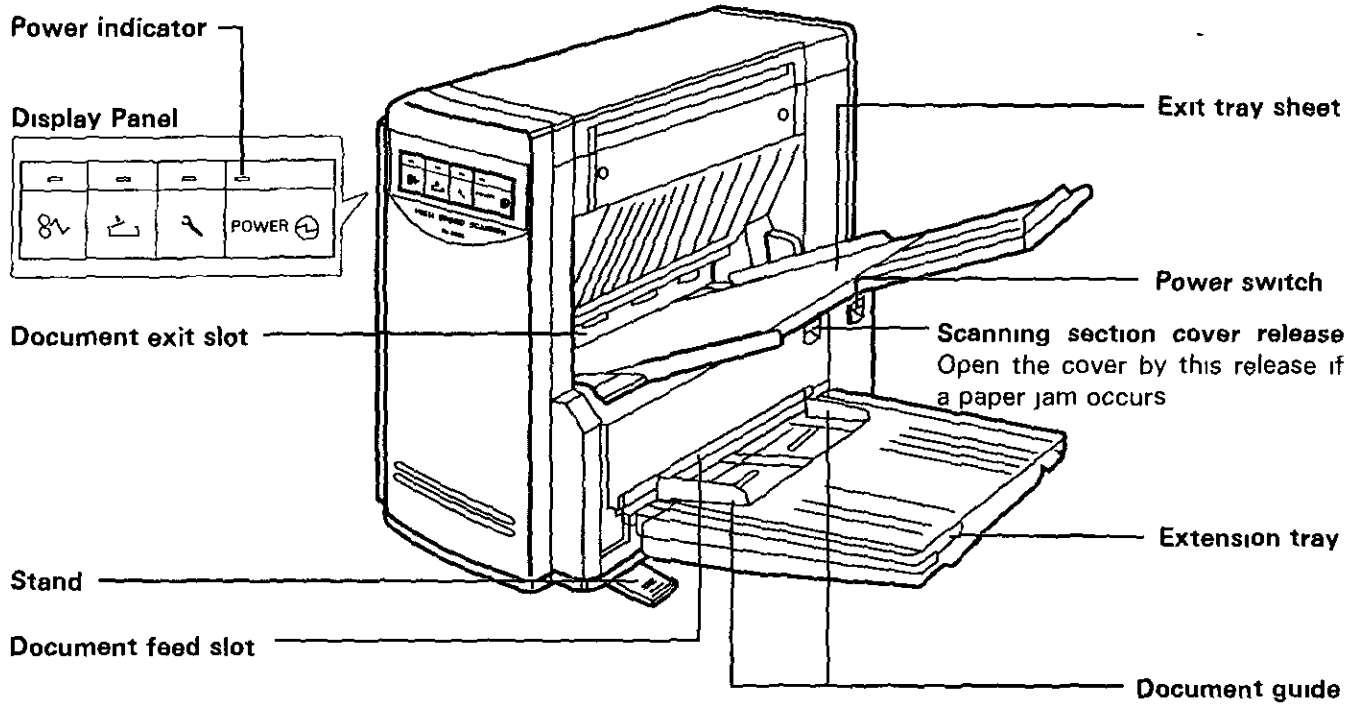

# Minimum Space and Installing the Stand

## Minimum space

Be sure to maintain the recommended space requirements for proper ventilation

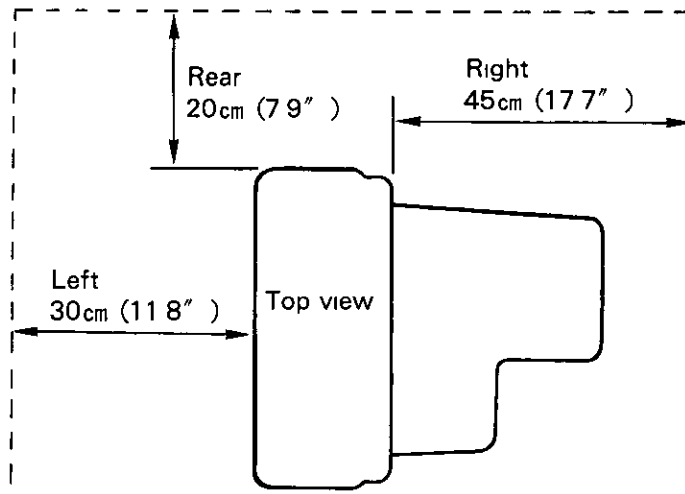

## Installing the stand

### 1 Lift the unit

- Do not hold the unit by the document feed slot

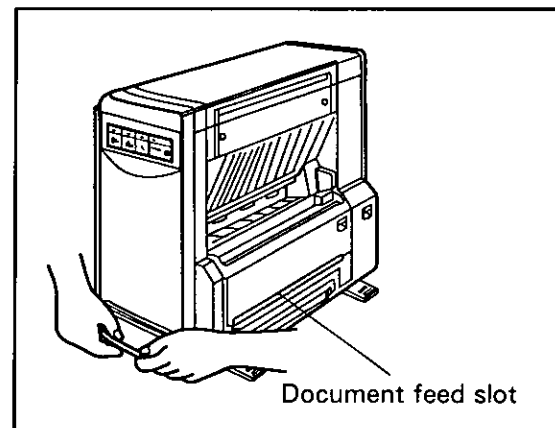

### 2 Turn the four feet until they appear as in the illustration

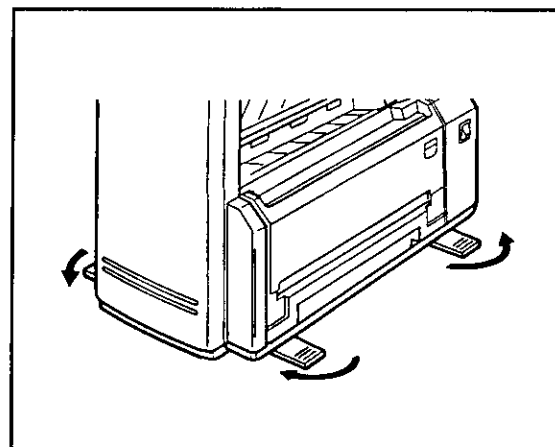



# Installing the Document Tray and the Exit Tray

- 1** Align both sides of the tray with the document feed slot, then firmly insert the tray into the slot using both hands until a "click" is heard

**Caution**

Before installing the document tray, be sure to perform the following procedure

- ① Connect the power cord
- ② Turn the power switch on and initialize the unit for approximately 15 seconds

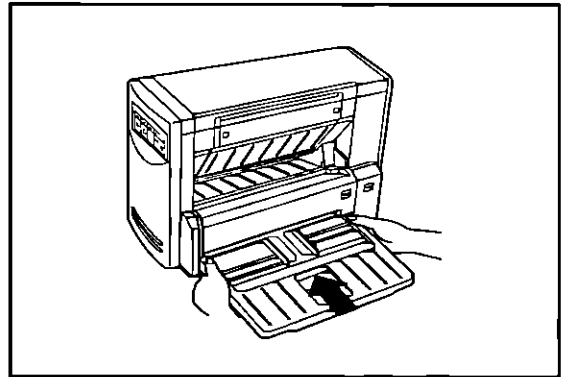

- 2** Insert both ends of the exit tray into the holes at the sides of the document exit slot

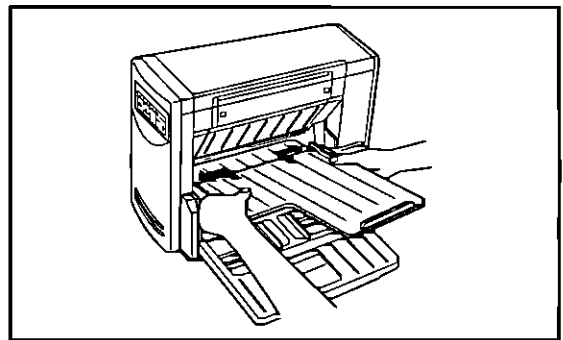

- 3** Remove the protective cover from the adhesive strip on the exit tray sheet  
Place the exit tray sheet into the rear of the document exit area and attach to the exit tray

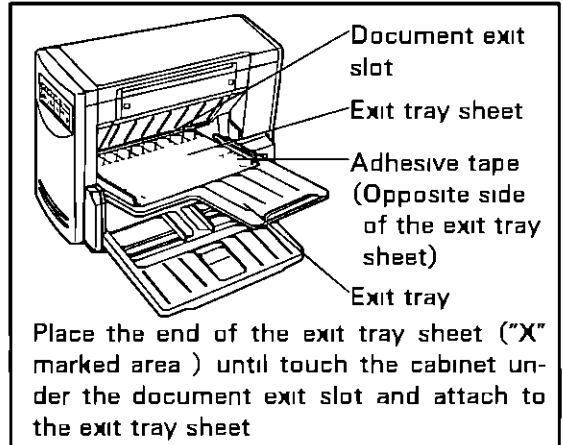

## Removing the exit tray

Slightly bend the exit tray while pulling it toward you, as shown in the figure

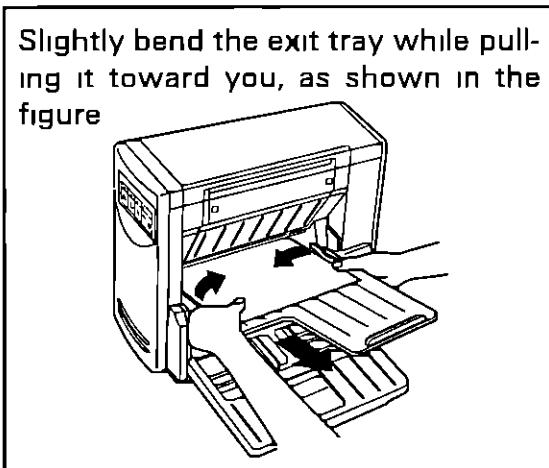

## Removing the document tray

Grasp the document tray as shown in the figure, then lift slightly and pull it toward you

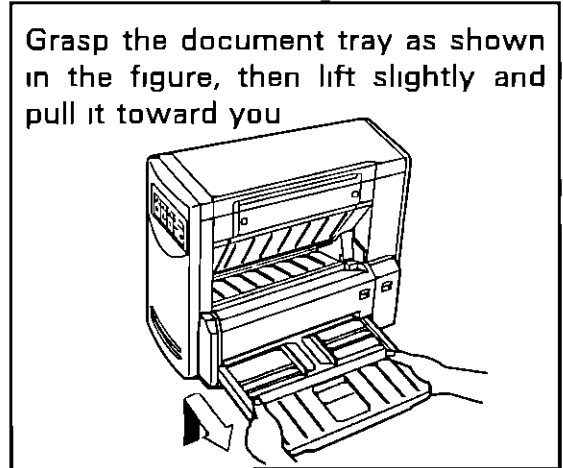

# Loading a Document

- 1** Documents that have been stapled together or have been sitting together (as in a file folder) for some time will need to be separated  
Fan the stack of document to separate all edges  
Hold both ends of the document and bend the documents as shown in the illustration to separate the centers  
Hold the documents firmly and pull them apart as shown in the illustration to straighten  
Repeat these steps as necessary

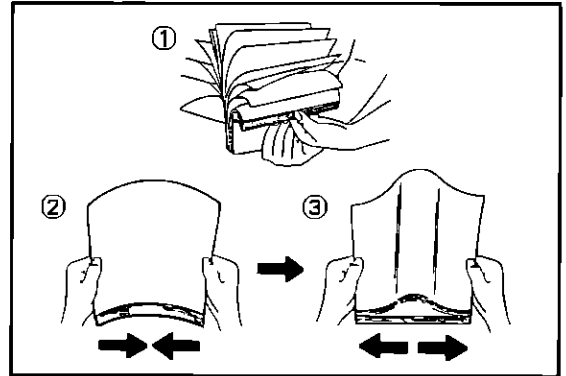

- 2** Carefully align the documents

- 3** Place the documents on the document tray with the side to be scanned facing up, then push them in the direction of the arrow until they stop

- Be sure to place the documents on the document tray in the lengthwise direction (see figure at right)  
The amount of documents should not exceed the limit mark on the document guide. This may cause a paper jam or skew

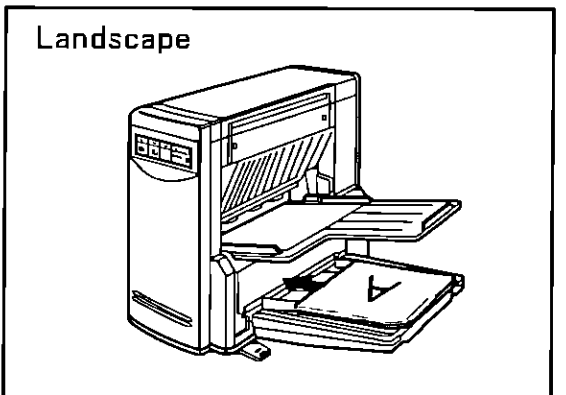
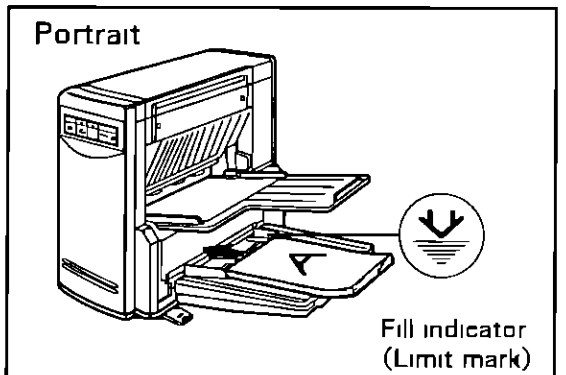

### 4 Adjust the document guides to the document size

- Make sure to properly align the documents to the document guide

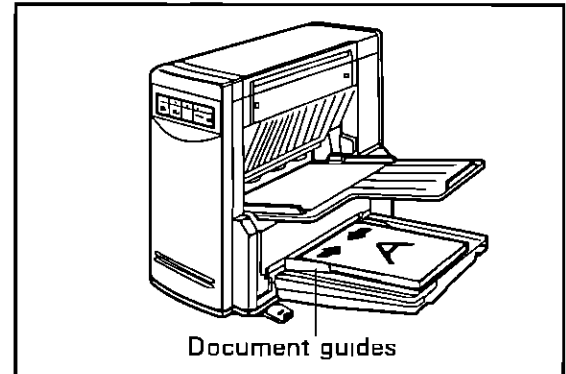

### 5 When using legal paper, pull out the extension tray from the document tray as shown in the illustration

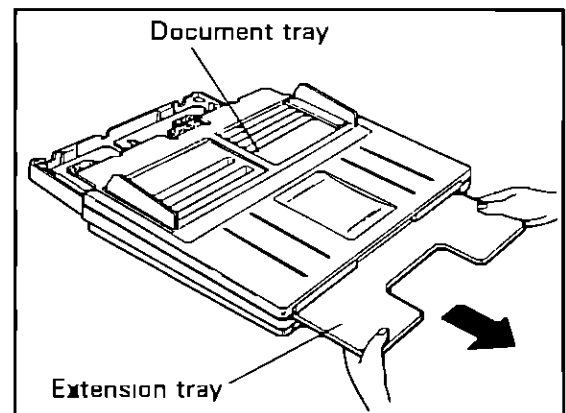

### Caution :

- For thin or thick paper, scan the document using single paper feed Also, remove the document from the exit tray after it is scanned
- The scanner will accept 13 to 27 lb paper for continuous scanning and 11 to 34 lb paper for a single scan
- You can load up to 80 sheets of 20 lb paper (limit mark of the document guide) Never allow the amount of documents in the tray to exceed the fill indicator Reduce the number of documents in the tray if they are thick, creased, or curled
- Be sure to remove the document from the exit tray after it is scanned
- Especially when reading an important document, in case of a paper jam or damage to the document, make a copy and use it to scan into the unit

### Types of Documents to Avoid :

- OHP sheets, other plastic film, cloth, or metallic sheets
- Paper with irregularities such as tabs, staples, paste etc
- Documents with wet ink
- Thick or irregular documents such as envelopes, paste, ups, etc
- Coated documents, photos
- Copying paper such as carbons or carbonless paper
- Damaged or wrinkled documents
- Unusually shaped documents
- Tracing paper

# Clearing Paper Jams

Torn documents, thin documents or documents that are creased at the leading edge may cause paper jamming. If a paper jam occurs (the lamp "8v" to indicate "Paper jam" will light on the Display Panel), remove the jammed sheet according to the following procedure.

## ● Removing paper jams from the scanner

Remove the exit tray, document tray and open the scanning section cover by inserting your finger into the cover release and gently pulling up the tab while pushing down the cover slightly.

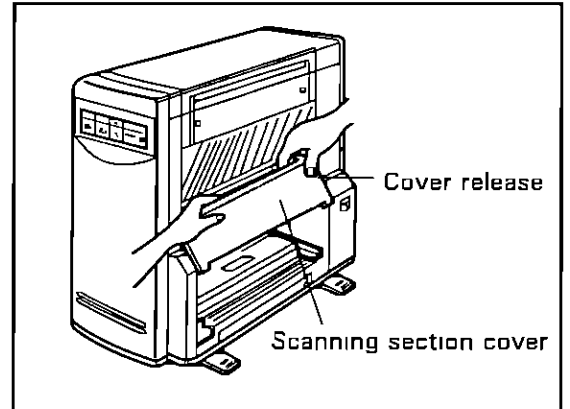

## ● If the paper cannot be removed by pulling it forward

Open the cover and then open the scanning section cover inside by pulling the tab toward the front.

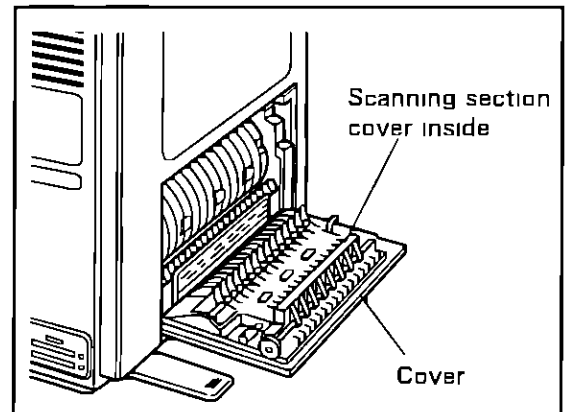

# Cleaning the Unit

---

## Outside of the Unit :

- at least once a month

- 1** Turn the power OFF
- 2** Clean the cover with a soft cloth
- 3** Remove dirt and dust from the fan exhaust vent with a brush

## Inside of the Scanner :

- Please clean the unit once a month, when 50,000 sheets or more are fed into the unit, or at the earliest opportunity
- When you experience paper jamming or multiple sheet feeding problems, follow steps 1 through 4 for cleaning the rollers and paper sensors
- When black vertical lines appear on the scanned image, please follow steps 1 and 5 for cleaning the reading element

- 1** Turn the power OFF
- 2** When a jam or misfeed occurs, clean the rollers (parts ① to ⑦) with a clean cloth as shown in the figure on the right

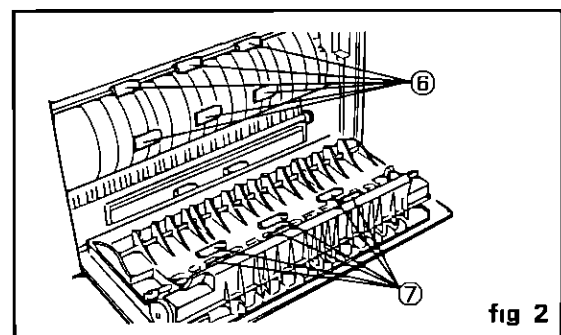
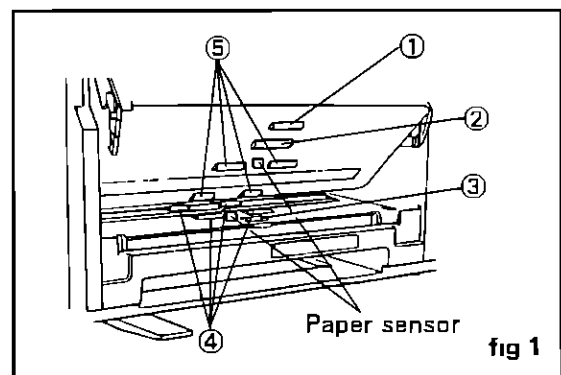

## Cleaning the Unit

---

**3** When the parts are especially dirty, use a soft, clean cloth and alcohol, wipe clean all of the dirty parts while rotating the roller in the direction of the arrows shown in the figure

- Please only use isopropyl alcohol. Do not use other thinners or the like
- When feeding of multiple sheets occurs often clean the rollers (parts ①, ② and ③) with isopropyl alcohol

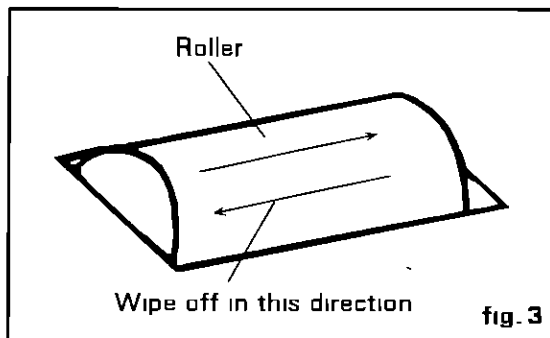

**4** Clean the paper sensors shown in fig 1, using a dry, clean cloth

**5** When the scanned image has vertical black lines, wipe the glass and white reference plate clean using a dry, clean cloth as shown in the figure on the right

- When especially dirty, use a soft, clean cloth and alcohol to wipe clean.
- Please only use isopropyl alcohol. Do not use other thinners or the like

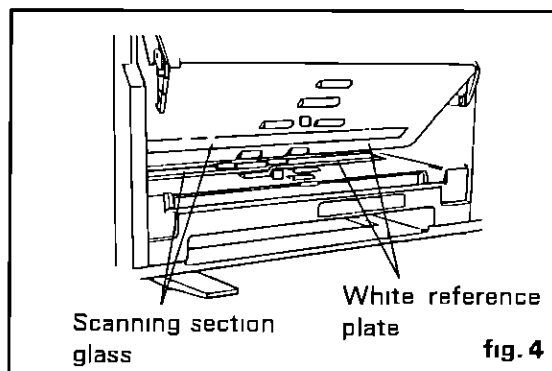

# Repacking Instructions

It is highly recommended that you keep the original carton and ALL packing materials. Should you need to transport or ship your scanner, please follow these instructions.

## Please Note :

- Please use the original carton and all of the original packing materials. If you do not have the original packing material, a Reshipping Kit is available from Panasonic. The order number for the Reshipping Kit is PJKT2P5400M. Please refer to your servicing dealer, or call 1-800-346-4768 (KV-SS25 only).
- Improper repacking of the scanner may result in a service charge to repair the unit.
- The scanner should be handled in the upright (vertical) position.

## Material Required :

- Original Scanner Carton & Packing Materials
- Shipping Tape and Scissors

**1** Disconnect your scanner from the electrical outlet and the SCSI interface cable





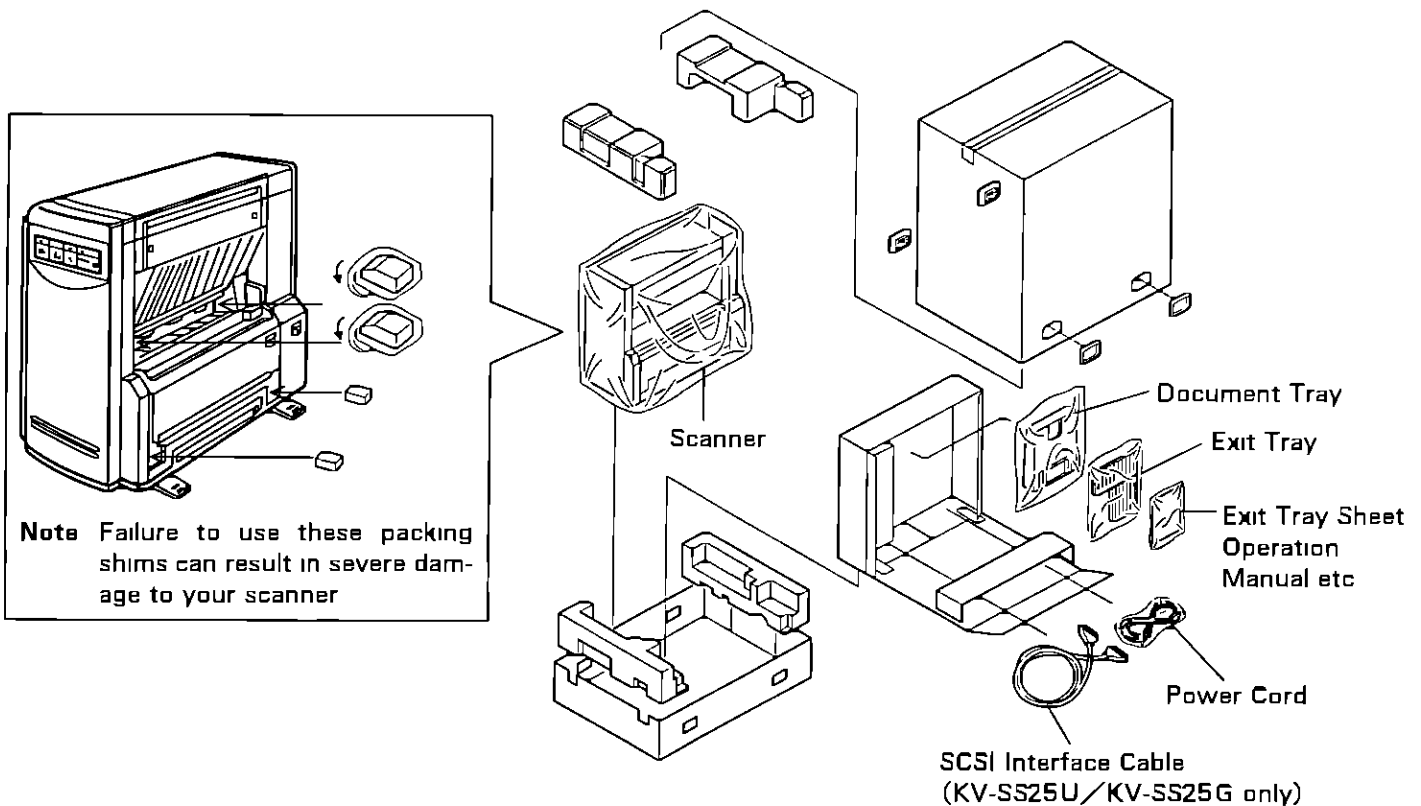

**2** Close the scanner stands into their shipping positions

**3** Packing the scanner



# Troubleshooting

If a problem occurs while the unit is being used, first check the following items. If the unit still malfunctions, switch it OFF, and call service.

Symptom	Possible Cause	Remedy
Power indicator does not light when the power switch is turned ON	The power plug has come out	Insert the power plug firmly
	The fuse has blown	Pull out the power plug, then call service 
	Foreign matter is lodged in the fan, preventing it from rotating	
Scanning takes a long time to start, or does not take place at all	The fluorescent lamp in the scanner has reached the end of its life	Call service 
	The ambient temperature is less than 15°C (59°F)	Use the unit in a room where the ambient temperature is between 15°C and 30°C (59°F and 86°F)
Documents are not fed while scanning	 Documents are not loaded correctly	Align the front edges of the document, place them firmly against the document feed slot, then start scanning
	 Various covers are open	Close the covers firmly
	 There is a paper jam	Remove the jammed paper (see page 12)
	 The rollers are dirty	Wipe the rollers (see page 13)
Document stops during a scan	The document is creased or torn, or has a length of more than legal or less than 91×55mm (3 6×2 2in)	Make a copy of the document on paper of the specified size [between 91×55mm (3 6×2 2in) and Legal] and scan the copy
Document stops or is not fed smoothly during a scan	The rollers are dirty	Wipe the rollers (see page 13)
The scanned document is blank	The document to be scanned was loaded face down (upside down)	Load the document correctly
The scanned document is completely blank	The fluorescent lamp in the scanner has reached the end of its life	Call service 
Scanned document is skewed	The document guides were not touching the edges of the document, or the documents was skewed when loaded	Set the document guides or the document correctly
Vertical lines appear on the scanned document	The white reference plate, scanning section glass or the rubber rollers are dirty	Wipe the dirty part with a clean cloth (refer to page 13)
The computer cannot recognize scanner	The unit of the same SCSI ID number is connected to the computer	Change the SCSI ID number
	When the scanner is connected to the SCSI terminal, the terminator is not connected	Turn the SCSI terminator switch ON, or connect the terminator to the SCSI connector
	When the scanner is not connected to the SCSI terminal, the SCSI terminator switch is turned ON	Turn the SCSI terminator switch OFF



# Specifications

Item		Model No.	KV-SS25	KV-SS25U / KV-SS25G
Scanner	Scanning face		Duplex scanning	
	Scanning method		Front side CCD image sensor Reverse side Contact-type image sensor	
	Readout speed		Simplex scanning Approx 20 sheets/min (Letter, fed length-wise, 200 dpi) Duplex scanning Approx 10 sheets/min (Letter, fed length-wise, 200 dpi)	
	Resolution		Main scanning direction 150, 200, 240, 300dpi Sub-scanning direction 150, 200, 240, 300dpi (As same as main scanning direction)	
	Tonal gradation		Binary mode, grayscale mode, 64-step gradation (dither) mode, 64-step gradation (error diffusion) mode	
	Image control		Image emphasis, Automatic threshold, Automatic separation, Monochrome reversing, Automatic back control	
	Paper	Size		55×91mm (2.2×3.6 in) to Legal [216×355.6mm (8.5×14 in)]
Thickness			Single paper feed 0.05 to 0.2mm (2.0 to 7.9 mils) Continuous paper feed 0.06 to 0.15 mm (2.4 to 5.9 mils) Note 1 mil=1/1000 in	
Weight			Single paper feed 40 to 127 g/m <sup>2</sup> (11 to 34 lbs) Continuous paper feed 50 to 100 g/m <sup>2</sup> (13 to 27 lbs)	
Unit	External dimensions (Width×Depth×Height)		568×450×390mm (22.4×17.7×15.4 in)	
	Mass (Weight)		14kg [14kgf (31 lbs)]	
	Power requirement		120V±12V AC, 60Hz	220V-240V±22-24V AC, 50/60Hz
	Power consumption	Maximum, (scanning)		1.3A
Minimum, (standby)			0.5A	0.3A
Operating Environment	Operating temperature and humidity		15°C to 30°C (59°F to 86°F), 30% to 80%RH	
Storage Environment	Storage temperature and humidity		0°C to 35°C (32°F to 95°F), 10% to 80%RH	
Accessories	Document tray, Exit tray, Exit tray sheet, Power cord, Operation manual and Installation manual, Driver software (3.5" FD), SCSI interface cable (KV-SS25U / KV-SS25G only)			

"Weight in pounds" represents the weight of 500 [17×22 inches (432×559mm)] sheets

# Index

## A

AC inlet ..... 7

## C

Connector ..... 7  
Cleaning the unit ..... 13  
    Fan exhaust vent ..... 13  
    Paper sensor ..... 13  
    Scanning section glass ..... 14  
    White reference plate ..... 14  
Component identification ..... 7  
Cover ..... 7  
Cover release ..... 7

## D

Display panel ..... 7  
Document exit slot ..... 7  
Document feed slot ..... 7, 8  
Document tray ..... 7, 9, 11  
Document guide ..... 7, 10

## E

Exit tray ..... 7, 9  
Extension tray ..... 7, 11

## F

Fan exhaust vent ..... 7  
Fill indicator (Limit Mark) ..... 10

## I

Installation  
    Document tray ..... 9  
    Exit tray ..... 9  
    Stand ..... 8

## P

Power indicator ..... 7  
Power switch ..... 7  
Power cord ..... 7  
Power source ..... 6  
Paper jam ..... 12

## S

Stand ..... 7, 8  
Scanning section cover release ..... 7  
SCSI connector ..... 7  
Scanning section cover ..... 12  
Specifications ..... 17

## T

Troubleshooting ..... 16



**Panasonic Communications & Systems Company**  
**Division of Matsushita Electric Corporation of America**  
Two Panasonic Way, Secaucus, New Jersey 07094

**Matsushita Electric of Canada Limited**  
5770 Ambler Drive, Mississauga, Ontario, L4W2T3

**Matsushita Electric Industrial Co., Ltd.**  
Central P. O. BOX 288, Osaka 530-91, Japan