

PoulanXT[®]

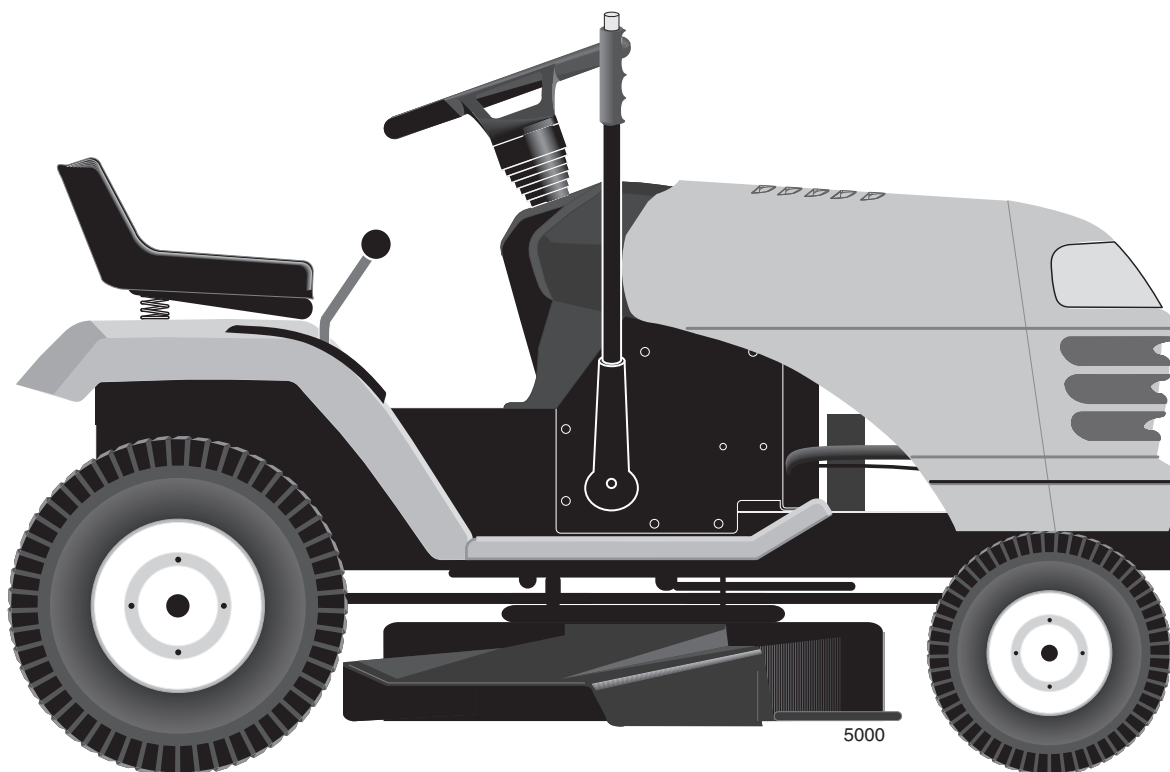

REPAIR PARTS MANUAL

MODEL:

PXT12538

LAWN TRACTOR

ALWAYS WEAR EYE PROTECTION DURING OPERATION

Visit our website: www.poulan-pro.com



WARNING:

Read this Manual and follow all Warnings and Safety Instructions. Failure to do so can result in serious injury.

HOW TO USE THIS MANUAL

This manual is designed to provide the customer with a means to identify the parts on his/her tractor when ordering repair parts. The illustrations may or may not represent the actual assemblies; therefore, it is not recommended to use this manual as a guide to assemble or disassemble the tractor. Some hardware and parts are drawn larger in order to more readily identify them.

Each tractor has its own model number.

The model number for your tractor can be found on the fender under the seat.

When ordering parts, always give the following information:

- Product - "TRACTOR"
- MODEL NUMBER - "PXT12538 (96016002200)"
- Part Number
- Part Description

TABLE OF CONTENTS

SCHEMATIC	3
ELECTRICAL.....	4-5
CHASSIS	6-7
DRIVE.....	8-9
ENGINE.....	10-11
STEERING	12-13
DECALS.....	14
SEAT	15
MOWER DECK	16-17
MOWER LIFT.....	18
WARRANTY.....	20

TRACTOR - - MODEL NO. PXT12538 (96016002200), PRODUCT NO. 960 16 00-22
SCHEMATIC 38

SCH03

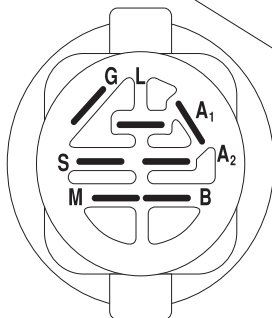
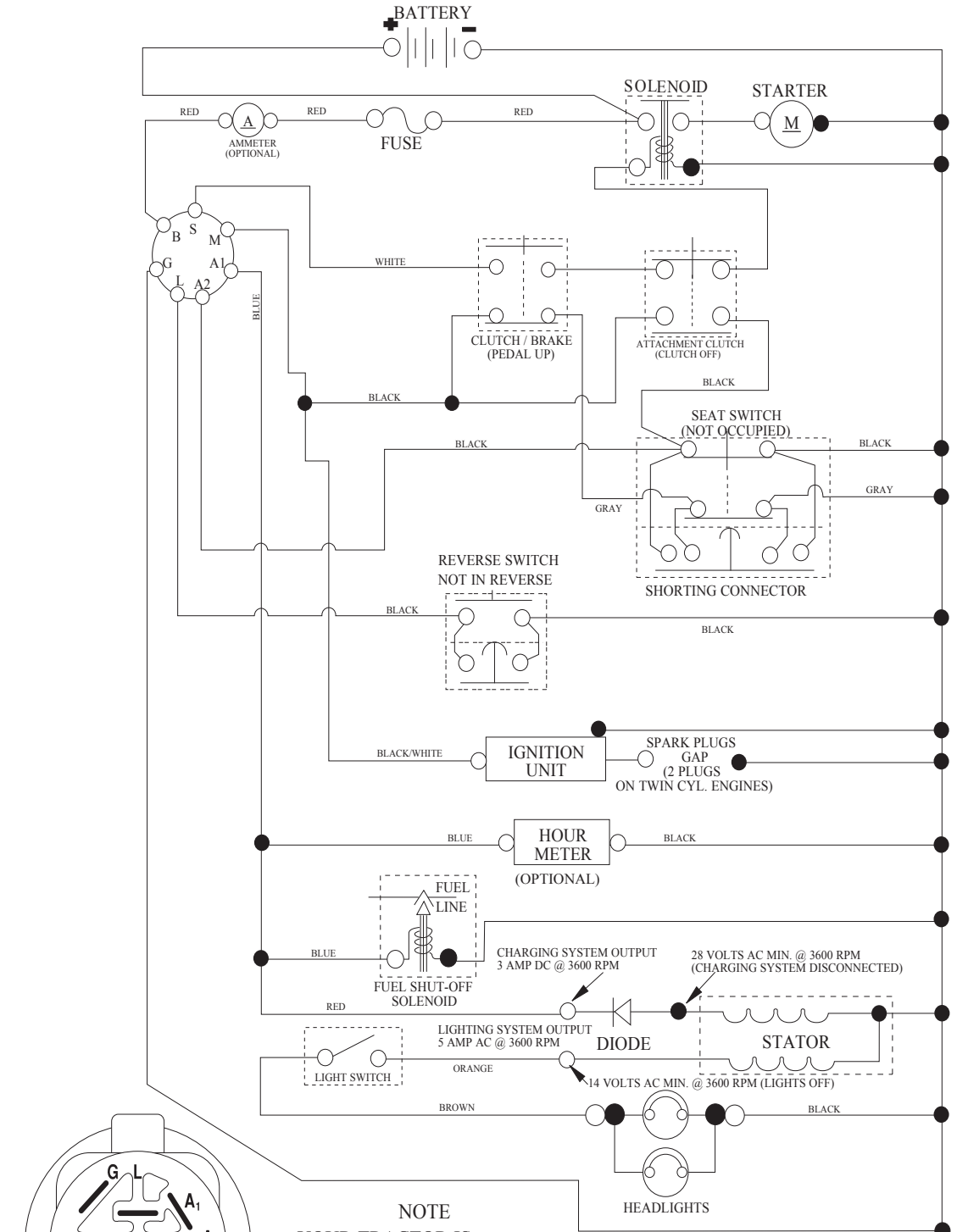

IGNITION SWITCH

POSITION	CIRCUIT	"MAKE"
OFF	M+G+A1	
RUN/OVERRIDE	B+A1	
RUN	B+A1	L+A2
START	B + S + A1	

NOTE
 YOUR TRACTOR IS EQUIPPED WITH A SPECIAL ALTERNATOR SYSTEM. THE LIGHTS ARE NOT CONNECTED TO THE BATTERY, BUT HAVE THEIR OWN ELECTRICAL SOURCE. BECAUSE OF THIS, THE BRIGHTNESS OF THE LIGHTS WILL CHANGE WITH ENGINE SPEED. AT IDLE THE LIGHTS WILL DIM. AS THE ENGINE IS SPEEDED UP, THE LIGHTS WILL BECOME THEIR BRIGHTEST.



WIRING INSULATED CLIPS
 NOTE: IF WIRING INSULATED CLIPS WERE REMOVED FOR SERVICING OF UNIT, THEY SHOULD BE RE-INSTALLED TO PROPERLY SECURE YOUR WIRING.

TRACTOR - - MODEL NO. PXT12538 (96016002200), PRODUCT NO. 960 16 00-22
ELECTRICAL **32**

L02

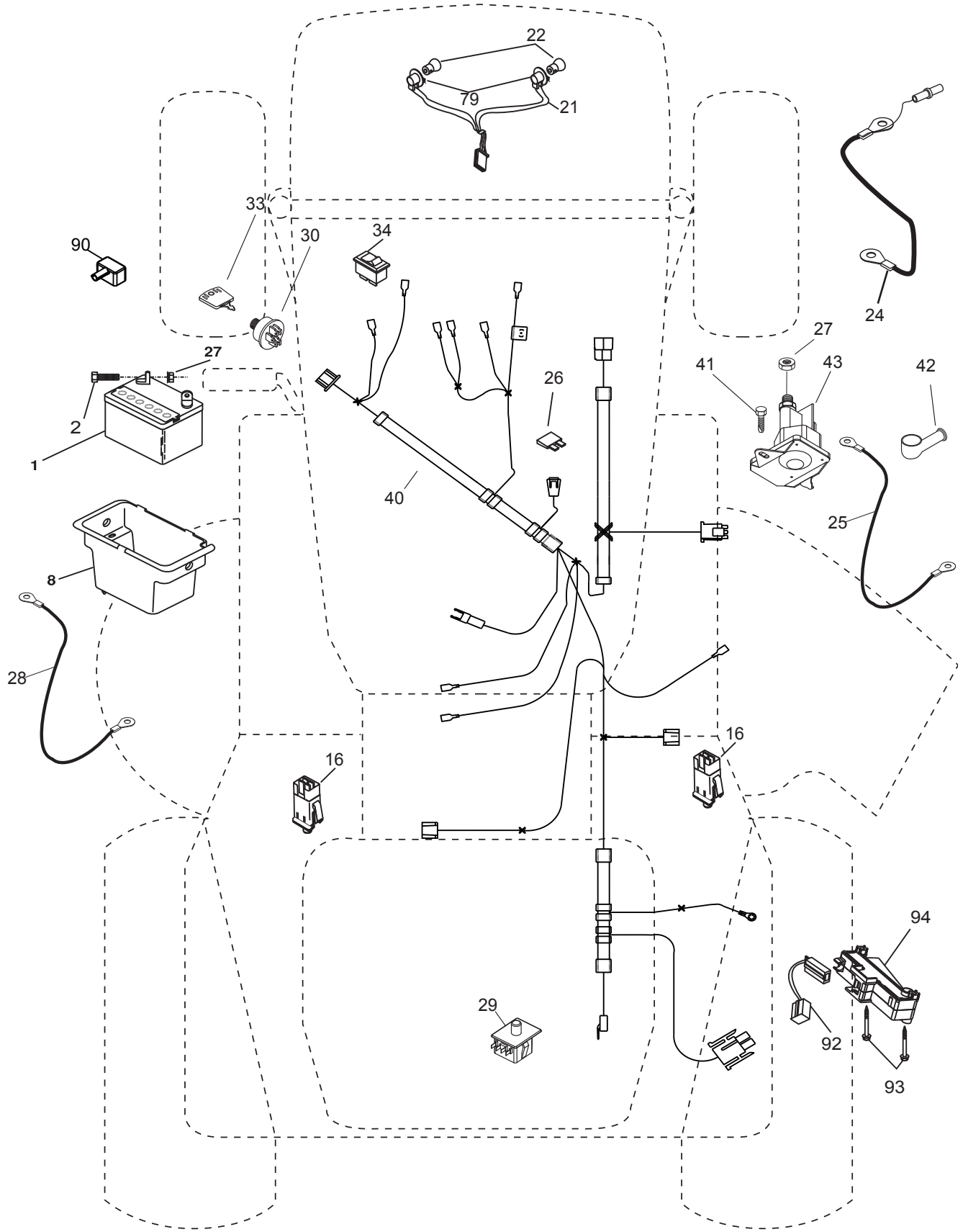

**TRACTOR - - MODEL NO. PXT12538 (96016002200), PRODUCT NO. 960 16 00-22
ELECTRICAL 32**

KEY NO.	PART NO.	DESCRIPTION
1	163465	Battery
2	74760412	Bolt Hex Hd 1/4-20 unc x 3/4
8	176689	Box Battery
16	176138	Switch Interlock
21	175688	Harness Asm Light w/4152j
22	4152J	Bulb Light #1156
24	421299	Cable Battery 6 Ga. 11" Red
25	421297	Cable Battery
26	175158	Fuse 20 AMP
27	73510400	Nut Keps Hex 1/4-20 unc
28	421298	Cable Ground 6 Ga. 12" Black
29	192749	Switch Seat
30	193350	Switch Ign
33	411935	Key/Chain
34	110712X	Switch Light/Reset
40	197428	Harness Ign
41	71110408	Bolt Blk Fin Hex 1/4-20
42	131563	Cover Terminal Red
43	192507	Solenoid
79	175242	Socket Asm. Bulb Twistlock
90	180449	Cover Terminal Battery
92	196615	Harness Pigtail
93	192540	Screw Plastite 10-14 x 2.0
94	191834	Module Reverse ROS

NOTE: All component dimensions given in U.S. inches
1 inch = 25.4 mm.

TRACTOR - - MODEL NO. PXT12538 (96016002200), PRODUCT NO. 960 16 00-22
 CHASSIS AND ENCLOSURES **39**

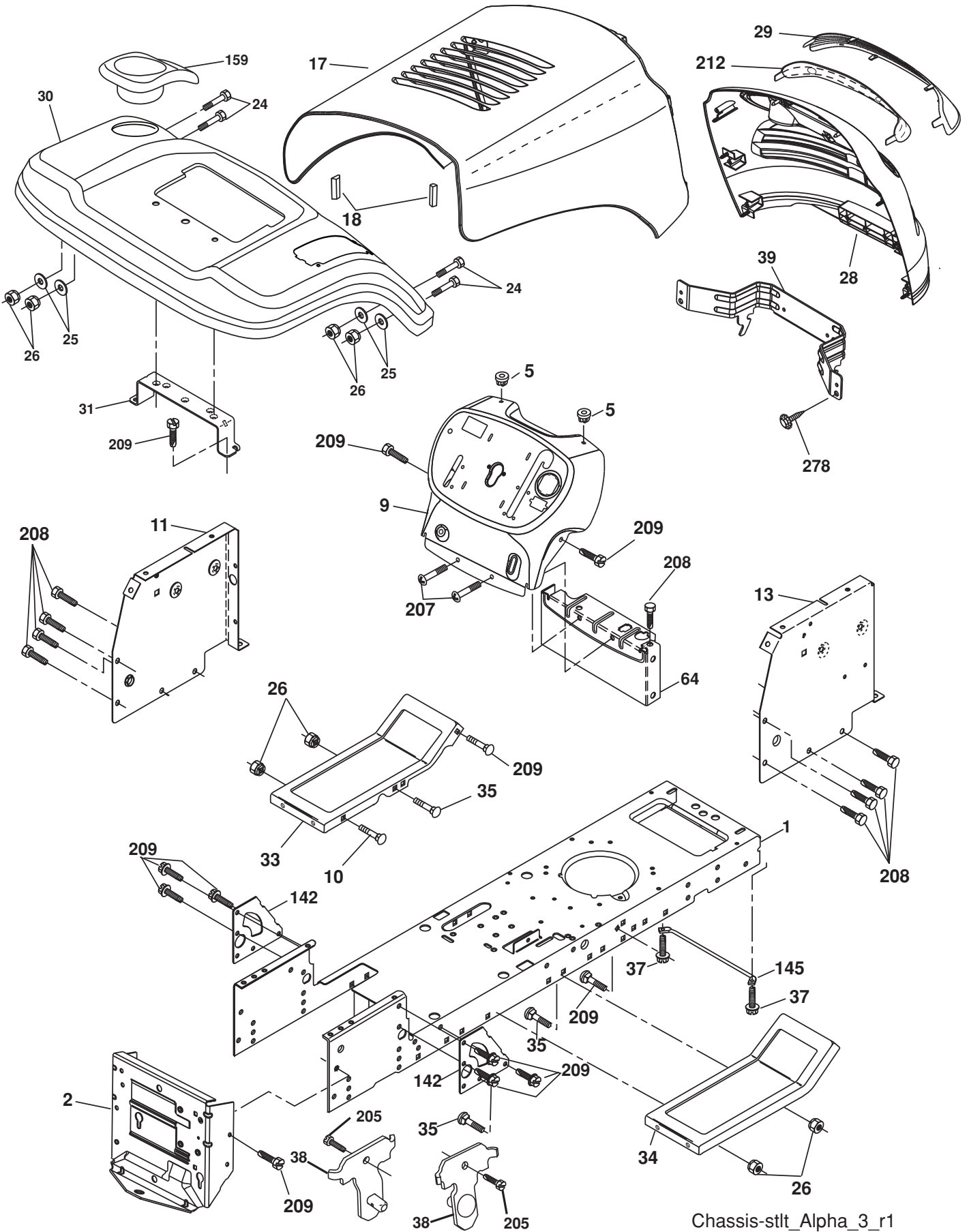

Chassis-stlt_Alpha_3_r1

**TRACTOR - - MODEL NO. PXT12538 (96016002200), PRODUCT NO. 960 16 00-22
CHASSIS AND ENCLOSURES **39****

KEY NO.	PART NO.	DESCRIPTION
1	174619	Chassis
2	176554	Drawbar, Stretch
5	155272	Bumper, Hood/Dash
9	428394X010	Dash
10	72140608	Bolt, Carriage 3/8-16 x 1
11	174996	Panel Dash LH
13	172105X010	Panel Slkscr Dash RH
17	187559X505	Hood
18	184921	Bumper Hood
24	74780616	Bolt Fin Hex 3/8-16 unc x 1 Gr. 5
25	19131312	Washer 13/32 x 13/16 x 12 Ga.
26	73800600	Nut Lock Hex w/Ins 3/8-16 unc
28	187565X428	Grille
29	187567X599	Lens Grille Bar
30	192528X505	Fender
31	136619	Bracket Fender Repl 109873X
33	179716X505	Footrest Pnt LH
34	179717X505	Footrest Pnt RH
35	72110606	Bolt Rdhd Sht Sqnk 3/8-16 x 3/4
37	17490508	Screw Thdrol 5/16-18 x 1/2 TYT
38	175710	Bracket Asm. Pivot Mower
39	187568	Bracket Pivot
64	154798	Dash Lower
142	175702	Plate Reinforcement
145	409167	Rod Pivot Chassis/Hood
159	169473X428	Cupholder
205	17490608	Screw Thdrol 3/8-16 x 1/2
207	17670508	Screw 5/16-18 x 1/2
208	17670608	Screw Thdrol 3/8-16 x 1/2
209	17000612	Screw Hex Wsh Thdrol 3/8-16
212	187569	Insert Lens Reflect
278	416358	Screw #10 x 0.750 BOS Thread
---	5479J	Plug Button Blk 359 Dia Choke
--	187801	Plug Dome Plastic

NOTE: All component dimensions given in U.S. inches
1 inch = 25.4 mm.

**TRACTOR - - MODEL NO. PXT12538 (96016002200), PRODUCT NO. 960 16 00-22
DRIVE 40**

KEY NO.	PART NO.	DESCRIPTION	KEY NO.	PART NO.	DESCRIPTION
1	-----	Transaxle Peerless 206-545C	65	10040700	Washer Lock Hvy Hlcl Spr 7/16
2	146682	Spring Return Brake T/a Zinc	66	154778	Keeper Belt Engine Foolproof
3	123666X	Pulley Transaxle 18" Tires	69	142432	Screw Hex wsh HiLo 1/4 x 1/2 unc
4	12000028	Ring Retainer # 5100-62	70	134683	Guide Belt Mower Drive RH
5	121520X	Strap Torque 30 Degrees	74	137057	Spacer Axle
6	17060512	Screw 5/16-18 x 3/4	75	121749X	Washer 25/32 x 1 1/4 x 16 Ga.
8	192706	Rod Shift Fender Adjust Lt	76	12000001	E-ring #5133-75
10	76020416	Pin Cotter 1/8 x 1 Cad	77	123583X	Key Square 2 0 x 1845/ 1865
11	105701X	Washer Plate Shf 388 Sq Hole	78	121748X	Washer 25/32 x 1-5/8 x 16 Ga.
13	74550412	Bolt 1/4-28 unf Gr. 8 w/Patch	79	2228M	Key Woodruff #9 3/16 x 3/4
14	10040400	Washer Lock Hvy Helical	80	131486	Arm Shift
15	74490560	Bolt Hex FLGHD 5/16-18 x 3.75	81	165594	Shaft Asm Cross Tapered PMST/20
16	73800500	Nut Lock Hex w/ins 5/16-18	82	165711	Spring Torsion T/a
18	74780616	Bolt, Fin Hex 3/8-16 unc x 1 Gr. 5	83	19171216	Washer 17/32 x 3/4 x 16 Ga.
19	73800600	Nut Lock 3/8-16 unc	84	166228	Link Transaxle
21	106933X	Knob	85	150360	Nut Lock Center 1/4 - 28 FNTHD
22	130804	Rod Brake	89	192053X428	Console Shift STLT
24	73350600	Nut Hex Jam 3/8-16 unc	96	4497H	Retainer Spring 1"
25	106888X	Spring Rod Brake 2 00 Zinc	112	19091210	Washer 9/32 x 3/4 x 10 Ga.
26	19131316	Washer 13/32 x 13/16 x 16 Ga.	113	127285X	Strap Torque LT
27	76020412	Pin Cotter 1/8 x 3/4 Cad	116	72140608	Bolt Rdhd Sq Neck 3/8-16 x 1
28	175765	Rod Brake Parking LT/YT	120	73900600	Nut Lock Fig. 3/8-16 unc
29	71673	Cap Brake Parking	150	175456	Spacer Retainer
30	174973	Bracket Mtg Transaxle	151	19133210	Washer 13/32 x 2 x 10
32	74760512	Bolt Hex Hd 5/16-18 unc x 3/4	156	166002	Washer Srrted 5/16ID x 1.125
34	175578	Shaft Asm Pedal Foot	158	165589	Bracket Shift Mount
35	120183X	Bearing Nylon Blk 629 Id	159	183900	Hub Tapered Flange Shift Lt
36	19211616	Washer 21/32 x 1 x 16 Ga.	161	72140406	Bolt Rdhd Sqnk 1/4-20 x 3/4
37	1572H	Pin Roll 3/16 x 1"	162	73680400	Nut Crownlock 1/4-20 unc
38	179114	Pulley Composite Flat	163	74780416	Bolt Hex Fin 1/4-20 unc x 1 Gr. 5
39	72110622	Bolt RDHD 3/8-16 unc x 2-3/4 Gr. 5	165	165623	Bracket Pivot Lever
41	175556	Keeper Belt Flat Idler	166	17490510	Screw 5/16-18 x 5/8
47	127783	Pulley Idler V Groove Plastic	168	165492	Bolt Shoulder 5/16-18 x .561
48	154407	Bellcrank Asm	169	165580	Plate Fastening
49	123205X	Retainer Belt Style Spring	170	187414	Keeper Belt Transaxle Gear
50	72110612	Bolt Carr. Sh. 3/8-16 x 1-1/2 Gr. 5	197	169613	Nyliner Snap-In
51	73680600	Nut Crownlock 3/8-16 unc	198	169593	Washer Nyliner
52	73680500	Nut Crownlock 5/16-18 unc	202	72110614	Bolt RdHd 3/8-16 unc x 1-3/4 Gr. 5
53	199652	Link Clutch	308	195785	Spacer Transaxle
55	105709X	Spring Return Clutch 6 75			
56	17060620	Screw 3/8-16 x 1-1/4			
57	138255	V-Belt Ground Drive			
62	8883R	Cover Pedal Blk Round			
63	175410	Engine Pulley			
64	173937	Bolt Hex			

NOTE: All component dimensions given in U.S. inches
1 inch = 25.4 mm

**TRACTOR - - MODEL NO. PXT12538 (96016002200), PRODUCT NO. 960 16 00-22
ENGINE 24**

KEY NO.	PART NO.	DESCRIPTION
1	170551	Control Th/ch Flag
2	17720408	Screw Hex Thd Cut 1/4-20 x 1/2
3	-----	Engine, B&S 219807-0389-B1
4	179758	Muffler Exhaust B&S
13	165291	Gasket Eng 1 313 Id Tin Plated
23	169837	Shield BRN/DBR Guard
29	137180	Kit Spark Arrester (Flat Scrn)
31	407545	Tank Fuel Front
32	425162	Cap Asm Fuel
33	123487X	Clamp Hose
37	401137	Line Fuel
40	124028X	Bushing Snap Nyl Blk Fuel Line
44	17670412	Screw Thdrol 1/4-20 x 3/4
45	17000612	Screw Hex Wsh Thdrol 3/8-16
46	19091416	Washer 9/32 x 7/8 x 16 Ga.
72	192334	Screw Socket Head 5/16-18 x 3/4
78	17060620	Screw 3/8-16 x 1-1/4
81	73510400	Nut Keps Hex 1/4-20 unc
122	421922	Extension Drain Oil

NOTE: All component dimensions given in U.S. inches
1 inch = 25.4 mm

For engine service and replacement parts, call the toll free number for your engine manufacturer listed below:

Briggs & Stratton 1-800-233-3723

Engine Power Rating Information

The gross power rating for individual gas engine models is labeled in accordance with SAE (Society of Automotive Engineers) code J1940 (Small Engine Power & Torque Rating Procedure), and rating performance has been obtained and corrected in accordance with SAE J1995 (Revision 2002-05). Torque values are derived at 3060 RPM; horsepower values are derived at 3600 RPM. Actual gross engine power will be lower and is affected by, among other things, ambient operating conditions and engine-to-engine variability. Given both the wide array of products on which engines are placed and the variety of environmental issues applicable to operating the equipment, the gas engine will not develop the rated gross power when used in a given piece of power equipment (actual "on-site" or net power). This difference is due to a variety of factors including, but not limited to, accessories (air cleaner, exhaust, charging, cooling, carburetor, fuel pump, etc.), application limitations, ambient operating conditions (temperature, humidity, altitude), and engine-to-engine variability. Due to manufacturing and capacity limitations, Briggs & Stratton may substitute an engine of higher rated power for this Series engine.

TRACTOR - - MODEL NO. PXT12538 (96016002200), PRODUCT NO. 960 16 00-22
STEERING ASSEMBLY **41**

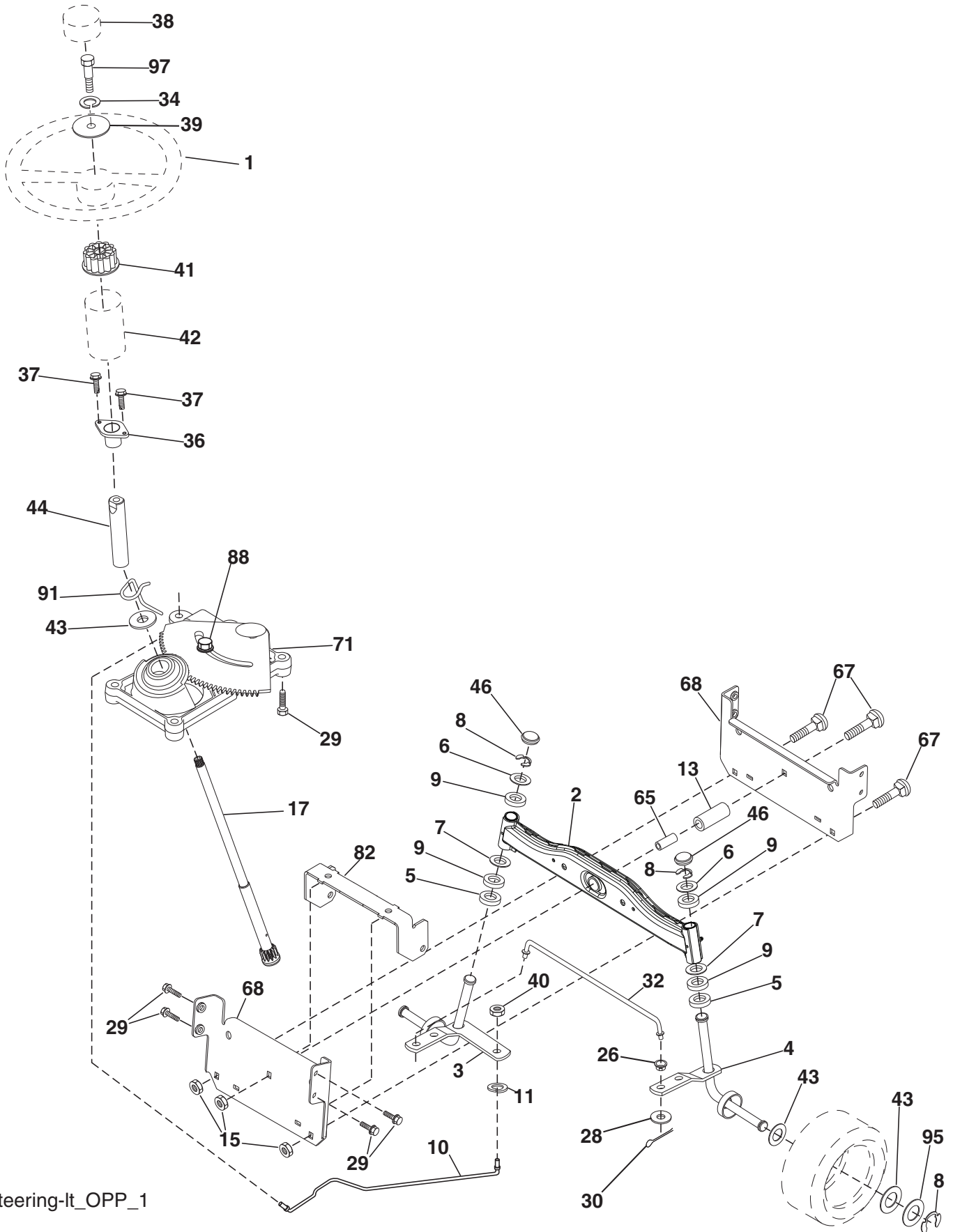

Steering-It_OPP_1

**TRACTOR - - MODEL NO. PXT12538 (96016002200), PRODUCT NO. 960 16 00-22
STEERING ASSEMBLY 41**

KEY NO.	PART NO.	DESCRIPTION
1	186780	Wheel Steering
2	418168	Axle Asm
3	169840	Spindle Asm LH
4	169839	Spindle Asm RH
5	6266H	Washer Thrust .75 x 1.230
6	121748X	Washer 25/32 x 1-5/8 x 16 Ga.
7	19272016	Washer 27/32 x 1-1/4 x 16 Ga.
8	12000029	Ring Klip #t5304-75
9	3366R	Bearing Col Strg Blk
10	175121	Link Drag
11	10040600	Washer Lock Hvy Hlcl Spr 3/8
13	136518	Spacer Brace Axle
15	73900600	Lock Nut Flg. 3/8-16 unc
17	411386	Shaft Asm Strg
26	126847X	Bushing Link Drag Blk LR
28	19131416	Washer 13/32 x 7/8 x 16 Ga.
29	17000612	Screw 3/8-16 x 3/4
30	76020412	Pin Cotter 11/32 ID x 2 3/8 OD x 12 Ga.
32	192757	Rod Tie Wire Form 19 75 Mech
34	10040500	Washer Lock 5/16
36	155099	Bushing Strg 5/8 Id Dash
37	152927	Screw
38	192916	Cap Wheel Steer
39	19113812	Washer 11/32 x 2 3/8 OD x 12 Ga.
40	73540600	Nut Crownlock 3/8-24
41	186737	Adaptor Wheel Strg
42	145054X428	Boot Dash Mtl Steering Blk
43	121749X	Washer 25/32 x 1 1/4 x 16 Ga.
44	190752	Extension Steering
46	121232X	Cap Spindle Fr Top Blk
65	414736	Spacer Brace Axle
67	72110618	Bolt RDHD SQNK 3/8-16 x 2-1/4
68	169827	Brace Axle
71	175146	Steering Asm.
82	199978	Bracket Susp Chassis Front
88	175118	Bolt Shoulder 7/16-20
91	175553	Clip Steering
95	188967	Washer Harden .793 x 1.637 x 060
97	428982	Bolt Fin Hx 5/16-18 x 4 w/Patch

NOTE: All component dimensions given in U.S. inches
1 inch = 25.4 mm.

**TRACTOR - - MODEL NO. PXT12538 (96016002200), PRODUCT NO. 960 16 00-22
DECALS 27**

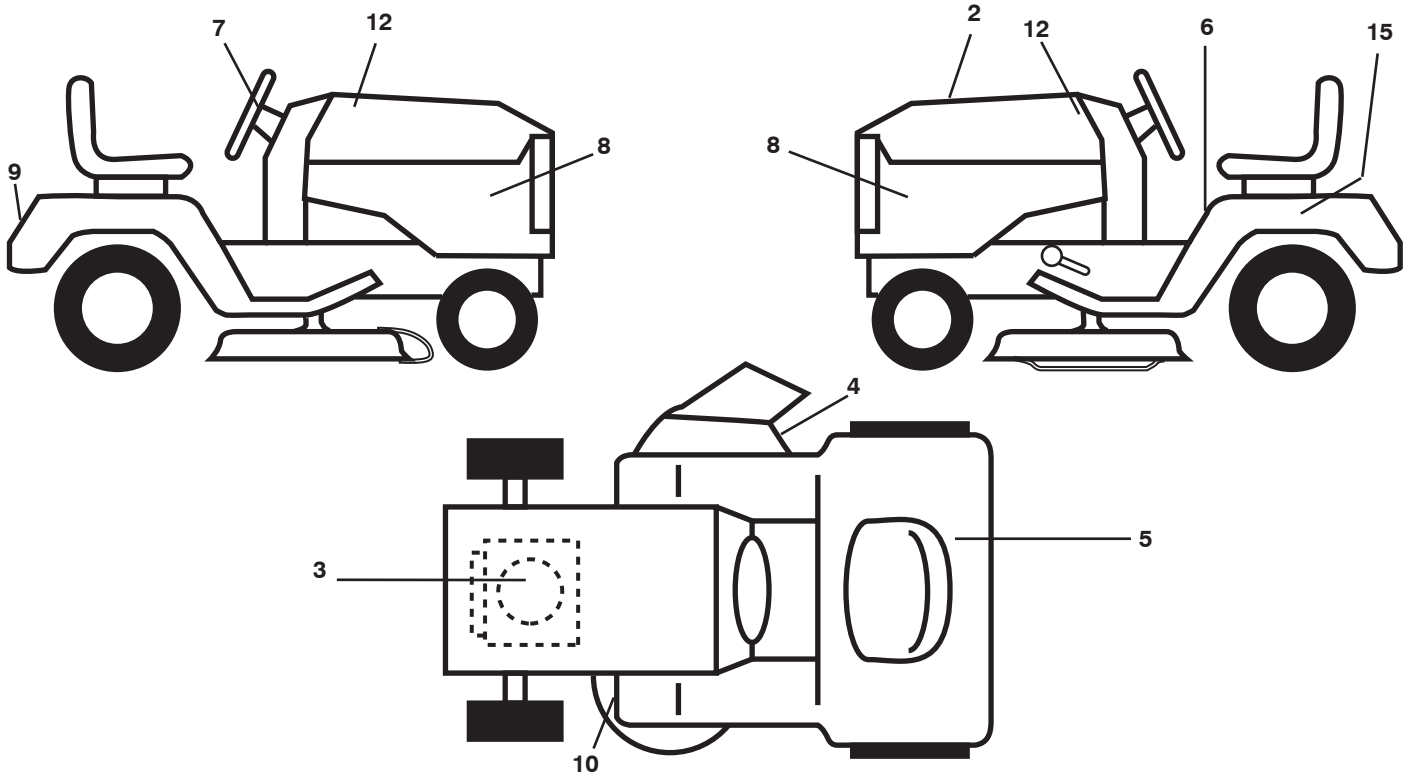

KEY NO.	PART NO.	DESCRIPTION	KEY NO.	PART NO.	DESCRIPTION
2	405121	Decal, Replacement	12	429170	Decal, Hood
3	408808	Decal, Engine HP	15	145005	Decal, Caution, Battery
4	170563	Decal, Warning	--	179769X428	Pad Foot Rest RH
5	431375	Decal, Fender Service	--	179768X428	Pad Foot Rest LH
6	411658	Decal, Fender Warning	--	138311	Decal, Handle Lft Height Adj.
7	437373	Decal, Ins Str Wh	--	431147	Manual, Operator's, English/French
8	431237	Decal, Side Panel	--	431148	Manual, Operator's, Spanish
9	429169	Decal, Fender	--	431150	Manual, Parts, English/French
10	194302	Decal, V-Belt Sch.			

WHEELS & TIRES

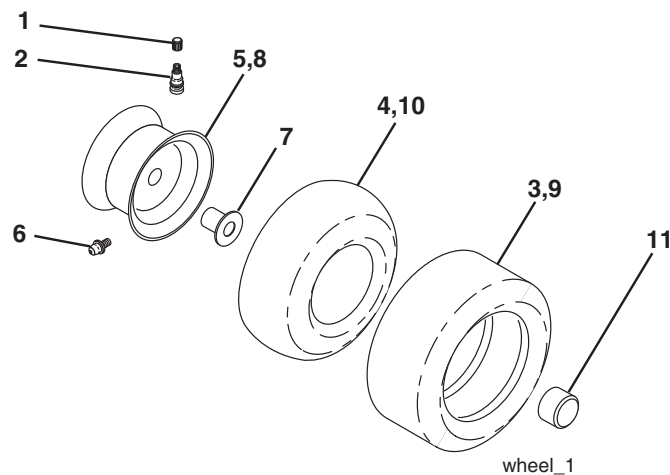

KEY NO.	PART NO.	DESCRIPTION
1	59192	Cap, Tire Valve
2	65139	Stem, Valve
3	123410X	Tire, Front
4	421652	Tube, Front (Service item only)
5	421554X643	Rim Assembly, 6" Front
6	278H	Fitting, Grease (Front wheel only)
7	9040H	Bearing, Flange (Front wheel only)
8	421533X643	Rim Assembly, 8" Rear
9	106230X	Tire, Rear
10	7154J	Tube, Rear (Service item only)
11	104757X643	Cap, Hub Axle
--	144334	Sealant, Tire (10 oz. Tube)

NOTE: All component dimensions given in U.S. inches
1 inch = 25.4 mm

**TRACTOR - - MODEL NO. PXT12538 (96016002200), PRODUCT NO. 960 16 00-22
SEAT ASSEMBLY 42**

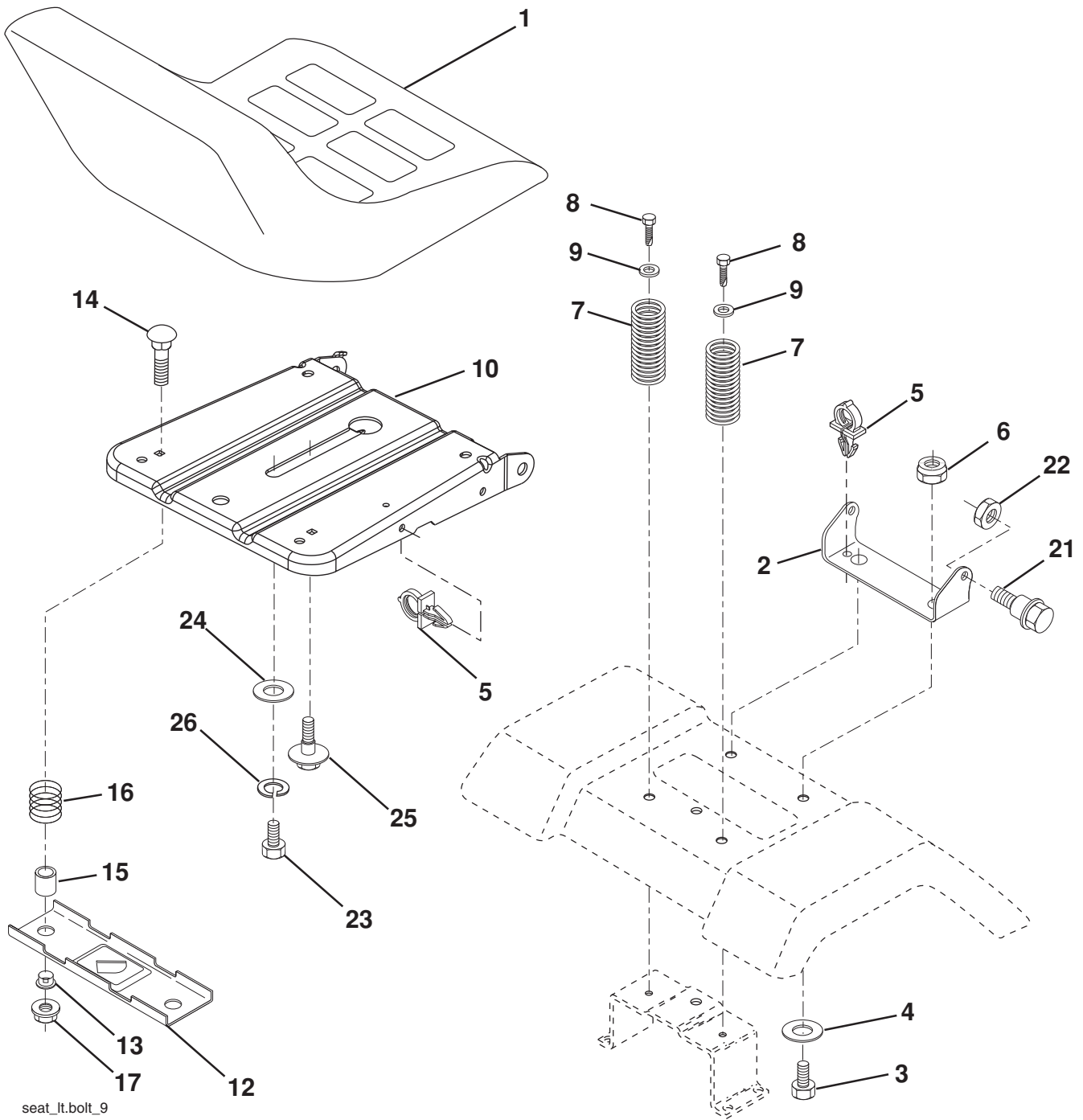

seat_lt.bolt_9

KEY NO.	PART NO.	DESCRIPTION
1	424035	Seat
2	140551	Bracket Seat Pivot
3	71110616	Bolt Hex 3/8 - 16 x 1
4	19131610	Washer 13/32 x 1 x10 Ga.
5	145006	Clip Push-In Hinged
6	73800600	Nut Lock Hex w/Ins 3/8 - 16
7	124181X	Spring Seat Cprsn 2 250 Blk Zi
8	17000616	Screw 3/8-16 x 1.5
9	19131614	Washer 13/32 x 1 x 14 Ga.
10	195530	Pan Pnt Seat
12	174648	Bracket Pnt Mounting Switch
13	121248X	Bushing Snap Blk Nyl
14	72050412	Bolt Rdhd Sht Nk 1/4 - 20 x 1 -1/2

KEY NO.	PART NO.	DESCRIPTION
15	134300	Spacer Split .28 x .96
16	121250X	Spring Cprsn
17	123976X	Nut Lock 1/4 Lge Flg
21	171852	Bolt Shoulder 5/16-18 unc-2A
22	73800500	Nut Lock Hex w/Ins 5/16 - 18
23	71110814	Bolt Hex
24	19171912	Washer 17/32 x 1-3/16 x 12 Ga.
25	127018X	Bolt Shoulder 5/16-18 x .62
26	10040800	Washer Lock Hvy Hlcl Spr 1/2

NOTE: All component dimensions given in U.S. inches
1 inch = 25.4 mm.

**TRACTOR - - MODEL NO. PXT12538 (96016002200), PRODUCT NO. 960 16 00-22
MOWER DECK 44**

KEY NO.	PART NO.	DESCRIPTION	KEY NO.	PART NO.	DESCRIPTION
1	192556	Mower Housing Assembly	72	193216	Spring Brake Return
2	72140506	Bolt Carriage 5/16-18 x 3/4	89	19131311	Washer 13/32 x 13/16 x 11 Ga.
3	138017	Bracket Asm Fr. Sway Bar	107	133502	Spacer Retainer
4	192568	Bracket Deck Sway Bar 38"/42"	108	133503	Stiffener, Idler Arm
5	4939M	Retainer Spring	122	410189	Rod, Brake LH
6	178024	Bar Sway Deck	123	410190	Rod, Brake RH
7	73800500	Nut Lock Hex w/Ins. 5/16-18 unc	144	193414	Keeper Belt Idler Tension
8	193003	Bolt 3/8-24 x 1.25 Gr. 8	148	169022	Spring Return Idler
11	193957	Blade Mower	149	165898	Retainer Spring Yellow
- -	138497	Blade 38" Hi-Lift	150	19091210	Washer 9/32 x 3/4 x 10 Ga.
13	192872	Shaft Assembly, Mandrel, Vented	152	193235	Clutch Cable 38"/46"
14	187281	Housing, Mandrel, Vented	158	17720408	Screw Hex Thd. Cut. 1/4-20 x 1/2
15	110485X	Bearing, Ball, Mandrel	185	188234	Head Asm. Cable Clutch
18	72140505	Bolt Rdhd. Sqnk. 5/16-18 x 5/8	186	17490644	Screw Hex Wsh. Thdrol. 3/8-16 x 2-3/4
19	132827	Bolt, Shoulder	187	193412	Keeper Belt
20	400095	Baffle Vortex Front	188	165891	Bolt Carriage Idler
21	73680500	Nut	189	192559	Stand, Brake
23	192557	Bracket, Mower Deflector	190	192560	Arm, Brake
24	105304X	Cap, Sleeve	191	192561	Spacer, Brake
25	197026	Spring, Torsion, Deflector	193	193413	Keeper Belt RH Mandrel
26	110452X	Nut, Push	194	194105	Guard Brake
27	192572X428	Shield, Deflector	195	19133210	Washer
29	131491	Rod, Hinge	208	17670608	Screw Thdrol 3/8-16 x 1/2
30	173984	Screw Thdrol.	214	193782	Bolt/Washer Asm. 5/16-18
31	187690	Washer, Spacer	- -	192558	Brake Assembly (Includes Stand, Arm and Guard Components)
32	153532	Pulley, Mandrel	- -	192870	Mandrel Assembly (Includes housing, shaft assembly, and bearing only - pulley/nut/washer and blade bolt/washers not included)
33	400234	Nut, Toplock	- -	193646	Replacement Mower, Complete
36	131494	Pulley, Idler, Flat			
37	193198	Pulley Idler Flat			
40	73680600	Nut, Crownlock 3/8-16 unc			
45	4497H	Retainer Spring			
55	133840	Idler Arm Assembly			
56	165723	Spacer, Retainer			
67	106932X	Knob			
68	193214	V-Belt			

NOTE: All component dimensions given in U.S. inches
1 inch = 25.4 mm

TRACTOR - - MODEL NO. PXT12538 (96016002200), PRODUCT NO. 960 16 00-22
MOWER LIFT **45**

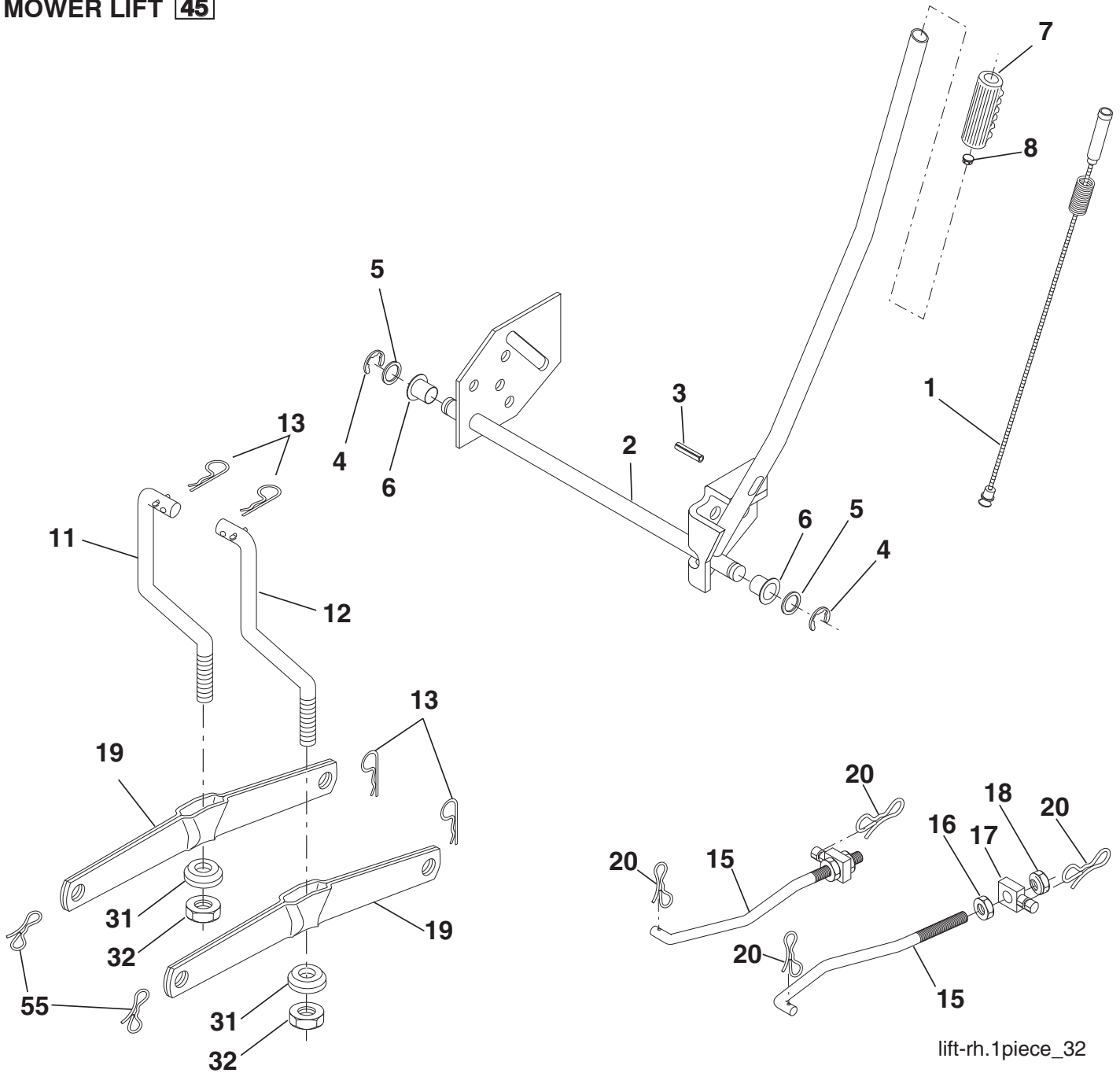

KEY NO.	PART NO.	DESCRIPTION
1	404981	Plunger Asm Lift Lever
2	159471	Shaft Asm Lift RH
3	105767X	Pin Groove 1 500 Zinc
4	12000002	E Ring #5133-62
5	19211621	Washer 21/32 x 1 x 21 Ga.
6	120183X	Bearing Nylon Blk 629 Id
7	125631X	Grip Handle
8	124526X	Button Plunger Black
11	139865	Link Lift LH Fixed Length
12	139866	Link Lift RH Fixed Length
13	4939M	Retainer Spring
15	173288	Link Front

KEY NO.	PART NO.	DESCRIPTION
16	73350800	Nut Jam Hex 1/2-13 unc
17	175689	Trunnion
18	73800800	Nut Lockw/Wsh 1/2-13 unc
19	139868	Arm Suspension Rear
20	194209	Pin Cotter 7/16 Bow Tie Lock
31	169865	Bearing Pvt Lift
32	73540600	Nut Crownlock 3/8-24
55	194208	Pin Cotter 5/16 Bow Tie Lock

NOTE: All component dimensions given in U.S. inches
1 inch = 25.4 mm.

SERVICE NOTES

LIMITED WARRANTY

The Manufacturer warrants to the original consumer purchaser that this product as manufactured is free from defects in materials and workmanship. For a period of two (2) years from date of purchase by the original consumer purchaser, we will repair or replace, at our option, without charge for parts or labor incurred in replacing parts, any part which we find to be defective due to materials or workmanship. This Warranty is subject to the following limitations and exclusions.

1. This warranty does not apply to the engine, transaxle/transmission components, battery (except as noted below) or components parts thereof. Please refer to the applicable manufacturer's warranty on these items.
2. Transportation charges for the movement of any power equipment unit or attachment are the responsibility of the purchaser. Transportation charges for any parts submitted for replacement under this warranty must be paid by the purchaser unless such return is requested by the manufacturer.
3. Battery Warranty: On products equipped with a Battery, we will replace, without charge to you, any battery which we find to be defective in manufacture, during the first ninety (90) days of ownership. After ninety (90) days, we will exchange the Battery, charging you 1/12 of the price of a new Battery for each full month from the date of the original sale. Battery must be maintained in accordance with the instructions furnished.
4. The Warranty period for any products used for rental or commercial purposes is limited to 90 days from the date of original purchase.
5. This Warranty applies only to products which have been properly assembled, adjusted, operated, and maintained in accordance with the instructions furnished. This Warranty does not apply to any product which has been subjected to alteration, misuse, abuse, improper assembly or installation, delivery damage, or to normal wear of the product.
6. Exclusions: Excluded from this Warranty are belts, blades, blade adapters, normal wear, normal adjustments, standard hardware and normal maintenance.
7. In the event you have a claim under this Warranty, you must return the product to an authorized service dealer.

Should you have any unanswered questions concerning this Warranty, please contact:

HOP
Outdoor Products Customer Service Dept.
1030 Stevens Creek Road
Augusta, GA 30907 USA

In Canada contact:
HOP
5855 Terry Fox Way
Mississauga, Ontario
L5V 3E4

giving the model number, serial number and date of purchase of your product and the name and address of the authorized dealer from whom it was purchased.

THIS WARRANTY DOES NOT APPLY TO INCIDENTAL OR CONSEQUENTIAL DAMAGES AND ANY IMPLIED WARRANTIES ARE LIMITED TO THE SAME TIME PERIODS STATED HEREIN FOR OUR EXPRESSED WARRANTIES. Some areas do not allow the limitation of consequential damages or limitations of how long an implied Warranty may last, so the above limitations or exclusions may not apply to you. This Warranty gives you specific legal rights, and you may have other rights which vary from locale to locale.

This is a limited Warranty within the meaning of that term as defined in the Magnuson-Moss Act of 1975.