

# ONKYO SERVICE MANUAL

## CASSETTE TAPE DECK COMPACT DISC PLAYER MODEL KCY-707

UD	120V AC, 60Hz
UM	220/230-240V AC, 50/60Hz

### SAFETY-RELATED COMPONENT WARNING!!

COMPONENTS IDENTIFIED BY MARK  $\Delta$  ON THE SCHEMATIC DIAGRAM AND IN THE PARTS LIST ARE CRITICAL FOR RISK OF FIRE AND ELECTRIC SHOCK. REPLACE THESE COMPONENTS WITH ONKYO PARTS WHOSE PARTS NUMBERS APPEAR AS SHOWN IN THIS MANUAL.

MAKE LEAKAGE-CURRENT OR RESISTANCE MEASUREMENTS TO DETERMINE THAT EXPOSED PARTS ARE ACCEPTABLY INSULATED FROM THE SUPPLY CIRCUIT BEFORE RETURNING THE APPLIANCE TO THE CUSTOMER.

### SPECIFICATIONS

#### CD Player Section

CD changer type:	10 disc bank system
Signal readout system:	Optical non-contact
Reading rotation:	About 500-200 r.p.m. (constant linear velocity)
Linear velocity:	1.2-1.4 m/s
Error correction system:	Cross Interleave Reed Solomon code
D/A converter:	1 Bit D/A converter
Sampling frequency:	176.4 KHz (four-times oversampling)
Number of channels:	2 (stereo)

#### Cassette Deck Section

Deck mechanism type;	Double auto reverse
Track format:	4-track, 2-channels
Erasing system:	AC erase
Tape speed:	4.8 cm/sec 9.6 cm/sec (high-speed dubbing)
Wow and Flutter:	0.12 % (WRMS)
Motors:	DC servo motor x 2
Heads:	REC/PB: 1 PB: 1 ERASE: 1

#### General

Power supply rating:	U.S.A. model: AC 120V, 60Hz Asian model: AC 220/230-240V, 50/60Hz
Dimensions (W x H x D):	270 x 185 x 322mm 10-5/8" x 7-5/16" x 12-11/16"

Specifications and external appearance are subject to change without notice because of product improvements.



# TABLE OF CONTENTS

Specification	1
Caution on replacement of optical pickup	2
Protection of eyes from laser beam during servicing	3
Laser warning labels	3
Adjustment procedures	4
Microprocessor terminal description	6
Chassis-exploded view	13
Parts list (chassis)	14
Cassette tape deck mechanism-exploded view	15
Parts list (deck mechanism)	17
CD mechanism-exploded view	18
Parts list (CD mechanism)	19
Printed circuit board parts list	20
Block diagram	21
Schematic diagram	27

## CAUTION ON REPLACEMENT OF OPTIONAL PICKUP

The laser diode in the optical pickup block is so sensitive to static electricity, surge current and etc, that the components are liable to be broken down or its reliability remarkably deteriorated.

During repair, carefully take the following precautions. (The following precautions are included in the service parts.)

### PRECAUTIONS

**1. Ground for the work-desk.**

Place a conductive sheet such as a sheet of copper (with impedance lower than  $10M\Omega$ ) on the work-desk and place the set on the conductive sheet so that the chassis.

**2. Grounding for the test equipment and tools.**

Test equipments and toolings should be grounded in order that their ground level is the same the ground of the power source.

**3. Grounding for the human body.**

Be sure to put on a wrist-strap for grounding whose other end is grounded.

Be particularly careful when the workers wear synthetic fiber clothes, or air is dry.

**4. Select a soldering iron that permits no leakage and have the tip of the iron well-grounded.**

**5. Do not check the laser diode terminals with the probe of a circuit tester or oscilloscope.**

# PROTECTION OF EYES FROM LASER BEAM DURING SERVICING

This set employs a laser. Therefore, be sure to follow carefully the instructions below when servicing.

## WARNING!!

WHEN SERVICING, DO NOT APPROACH THE LASER EXIT WITH THE EYE TOO CLOSELY. IN CASE IT IS NECESSARY TO CONFIRM LASER BEAM EMISSION, BE SURE TO OBSERVE FROM A DISTANCE OF MORE THAN 30cm FROM THE SURFACE OF THE OBJECTIVE LENS ON THE OPTICAL PICK-UP BLOCK.

## Laser Diode Properties

- Material: GaAS/GaAlAs
- Wavelength: 780nm
- Emission Duration: continuous
- Laser output: max. 0.5mW\*

\*This output is the value measured at a distance about 1.8mm from the objective lens surface on the Optical Pick-up Block.

## LASER WARNING LABELS

The label shown below are affixed.

### 1. Warning label

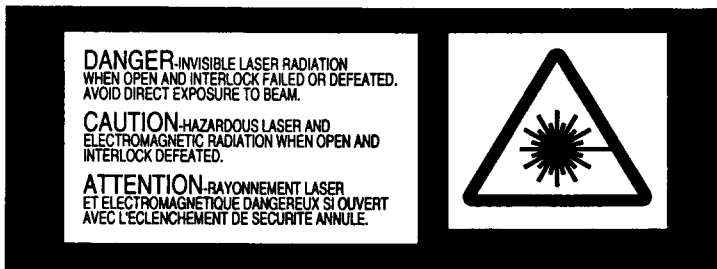

### 2. Class 1 label

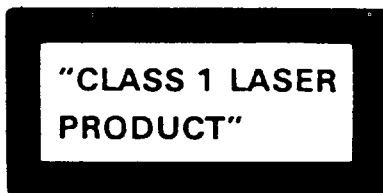

LUOKAN 1 LASERLAITE

KLASS 1 LASER APPARAT

### ADVARSEL

Denna mækning er anbragt på apparatets højre side og indikerer, at apparatet arbejder med laserstråler af klasse 1, hvilket betyder, at der anvendes laserstråler af svageste klasse, og at man ikke på apparatets yderside kan blive udsat for utilsigelig kraftig stråling.

APPARATET BØ/R KUN ÅBNES AF FAGFOLK MED SERLIGT KENDSKAB TIL APPARATER MED LASERSTRÅLERI

Indvendigt i apparatet er anbragt den her gengivne advarselmærkning, som advarer imod at foretage sådanne indgreb i apparatet, at man kan komme til at udsætte sig for laserstråling.

VAROITUS! LAITTEEN KAYTTAMINEN MUULLA KUIN TASSA KAYTTOOHJEESSA MAINTULLA TAVALLA SAATTA AALTISTAA KAYTTAJAN TURVALLISUUSLUOKAN 1 YLITTAVALLE NAKYMATTOMALLE LASERSATEILYLLE

# ADJUSTMENT PROCEDURES FOR CASSETTE TAPE DECK

## PRECAUTION

- Before adjustment, clean the following parts with an alcohol moistend swab.
  - \*record/playback head
  - \*erase head
  - \*pinch roller
  - \*capstan
- Do not use magnetized screwdriver for adjustment.
- Demagnetized record/plaiback head with a lead demagnetizer.

## TEST EQUIPMENT / TOOL REQUIRED

- Audio oscillator
- Digiyal frequency counter
- Oscilloscope
- Attenuator
- AC voltmeter
- Non-magnetic screwdriver
- Test tapes
  - TCC-153 : 10kHz, -10dB
  - MTT-111N : 3kHz, -10dB
  - MTT-150 : Dolby level calibration 400Hz, tone 200nWb/m

Item	Connection of instrument	Line input	Test tape	Mode	Output indicator	Adjustment point	Adjust	Remarks
1	Frequency counter to TP1,2 output terminal		MTT-111N	PB	Frequency counter	Nomal Speed VR809,811	3,000 to 3030Hz	
						High Speed VR810,812	6,000 to 6060Hz	
2	AC voltmeter and oscilloscope to TP1,2 output terminal		TCC-153	PB	AC voltmeter	Head azimuth screw	Maximum level & same phase at channels L and R	Fig.1
3	AC voltmeter to terminals TP1 (L) TP2 (R)		MTT-150	PB	AC voltmeter	A DECK VR803 (L ch) VR804 (R ch) B DECK VR806 (L ch) VR805 (R ch)	548mV (-3dBm)	
4	Frequency counter to erase head lead loose coupling		METAL TAPE	REC	Frequency counter	L803	85KHz	
5	AC voltmeter to TP1,2 output terminal	1kHz & 12kHz	NORMAL TAPE	REC/PB	AC voltmeter	VR802 (L ch) VR801 (R ch)	Same level at REC/PB	Fig.2
6	Fig.2	1kHz	NORMAL TAPE	REC	AC voltmeter	Attenuator or AF OSC output	245mV (-10dBm)	TP3 (L ch) TP4 (R ch)
				REC/PB	AC voltmeter	VR807 (L ch) VR808 (R ch)	Same level at REC/PB	TP1 (L ch) TP2 (R ch)

### Blank tapes

- NORMAL ··· UD-1 C-90
- HIGH ····· XL-II C-90
- METAL ···· XS C-90
- PLAY torque ····· 30~70g/cm
- FF.REW torque ····· 80~170g/cm
- Back tension ····· 2~6g/cm

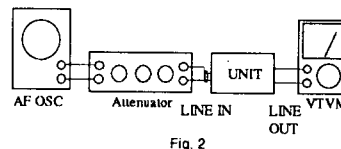
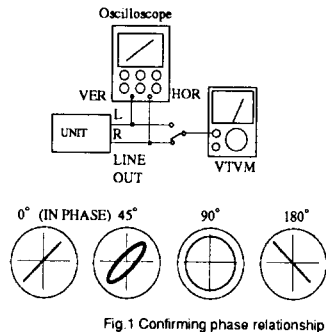

# ADJUSTMENT PROCEDURES FOR COMPACT DISC PLAYER

## E-F BALANCE ADJUSTMENT

### PROCEDURE:

1. Connect oscilloscope to the test points TE and Vref.
2. Press and hold down the SUPER DUBBING button, then press the POWER button.
3. Press FUNCTION CD button for 4 seconds or more. (CD section is TEST MODE.)
4. Put the disc (YEDS-18) in and press PLAY button.
5. Press the MEMORY button. (Tracking servo is OFF.)
6. Adjust VR701 so that the traverse waveform becomes symmetrical above and below.
7. Press the MEMORY button. (Tracking servo is ON.)
8. Press the STOP button.
9. Turn POWER switch off.

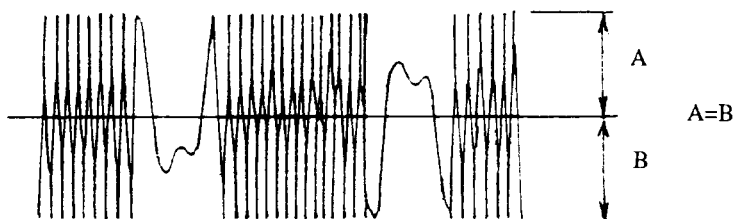

VOLT/DIV: 0.5V  
TIME/DIV: 1mSEC

## FOCUS BIAS ADJUSTMENT

### PROCEDURE:

1. Connect oscilloscope to test points RF and GND.
2. Turn POWER switch on.
3. Put disc (YEDS-18) in and press PLAY button.
4. Adjust VR702 for an optimum waveform eye pattern or so that the peak is maximum. Optimum eye pattern means that shape "◇" can be clearly distinguished at the center of the waveform.



RF signal waveform

Remarks: When adjusting, set the oscilloscope AC rang and raise its vertical sensitivity so that the eye pattern can easily be seen.

# MICROPROCESSOR TERMINAL DESCRIPTION

PIN NO.	SYMBOL	I/O	DESCRIPTION	PIN NO.	SYMBOL	I/O	DESCRIPTION
1	MB	O	Motor control for CD changer mechanism	41	SPXOE	O	Chip enable output to extended port IC
2	MC	O		42	NC	O	Not used
3	PRG	O	Plunger control for CD changer mechanism	43	CDCLK	O	Clock output to CD servo IC
4	CD-MUTE	O	Muting control for audio signal of CD	44	CDXLT	O	Data latch output to CD servo IC
5	CD-POWER	O	Power supply control for CD circuit	45	CDDATA	O	Data output to CD servo IC
6	AUSEL2	O	Output selector pin for CD or cassette signal	46	NC	I	Not used
7	AUSEL1	O		47	CDXRST	O	Reset input for CD section
8	TEST	I	Test mode setting input pin	48	S-CLK	I	Transfer clock signal input from main microprocessor
9	NC	O	Not used	49	S-IN	I	Transfer data signal input from main microprocessor
10	DOLBY	O	Dolby ON/OFF control	50	S-OUT	O	Transfer data signal output to main microprocessor
11	DUBBING	O	Dubbing setting signal	51	SQCLK	O	Data read clock output to CD DSP IC
12	L-MUTE	O	Muting control for audio signal of DECK	52	SQSI	I	Data input pin from CD DSP IC
13	HI-SPEED	O	Double speed dubbing control	53	NC	O	Not used
14	PB-SEL	O	Playback selector control for deck A/B	54	DISC-SEN	I	Detection input for size of CD
15	BIAS	O	Recording bias resonator control for cassette deck	55	TRV-DWN	I	Detection input for finish of down operation of traverse.
16	REC-MUTE	O	Recording muting control	56	TRV-UP	I	Detection input for finish of up operation of traverse.
17	REC/PB	O	Recording/playback control signal for deck B	57	TRY-CLS	I	Detection switch input for tray close
18	B-MTR	O	Motor speed control for deck B	58	NC	O	Not used
19	B-SOL	O	Solenoid coil control for deck B	59	NC	O	Not used
20	ERP-B	I	Prevention detection input for the side B of cassette tape	60	TRY-OPN	I	Detection switch input for tray open
21	ERP-A	I	Prevention detection input for the side A of cassette tape	61	LOAD-SEL	I	Detection sensor input for position of loading plate
22	B-PST	I	Detection input for cassette tape for deck B	62	S-RQO	O	Transfer request output to main microprocessor
23	B-END	I	Tape ending detection input for deck A	63	S-RQI	I	Transfer request input from main microprocessor
24	B-MODESW	I	Operation switch input for deck A	64	LOAD-SW	I	Position detection input for loading plate.
25	A-PST	I	Detection input for cassette tape for deck A	65	LEDS1	O	Scan signal output for operation indicator.
26	A-END	I	Tape finish detection input for deck A	66	LEDS2	O	
27	A-MODESW	I	Operation switch input for deck A	67	LEDS3	O	
28	A-SOL	O	Solenoid coil control for deck A	68	KEYIN0	I	Key matrix input
29	A-MTR	O	Motor speed control for deck A	69	KEYIN1	I	
30	RESET	I	Reset input for sub microprocessor	70	KEYIN2	I	
31	EXTAL	I	Resonator connection terminal for system clock	71	KEYIN3	I	
32	XTAL	-	Connect the 8.0MHz ceramic resonator.	72	Vdd	-	Power supply pin (+5V)
33	Vss	-	Ground pin	73	NC	-	Connect to +5v
34	NC	-	Not used	74	KEYIN4	I	Key matrix input
35	NC	I	Not used	75	KEYIN5	I	
36	AVss	-	Ground pin for A/D converter	76	KEYIN6	I	
37	AVref	-	Reference voltage pin for A/D converter	77	KEYIN7	I	
38	SPCLK	O	Clock output to extended port IC	78	CASE-POS	I	Sensor input for position of disc case
39	SPDATA	O	Data output to extended port IC	79	CASE-RST	I	Initialize position detection for disc case
40	SPLCK	O	Data latch output to extended port IC	80	MA	O	Motor control for CD changer mechanism

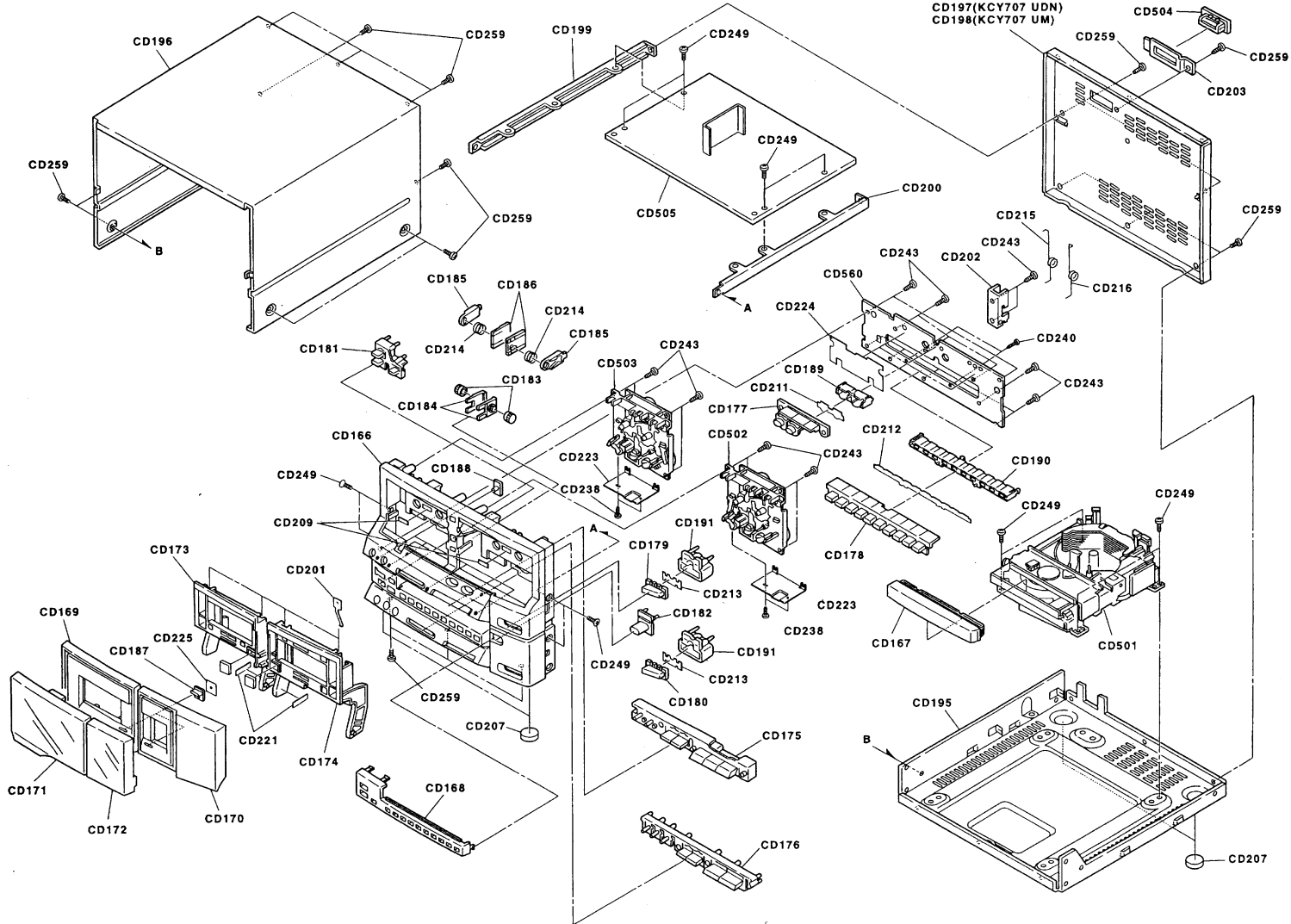

-13-

## PARTS LIST

REF. NO.	PART NO.	DESCRIPTION	REF. NO.	PART NO.	DESCRIPTION
166	10-3467010101	FRONT PANEL (A)	202	20-1129010101	TAPE HOLDER BRACKET
167	10-3468010101	CD DOOR	203	20-1168010101	CABLE BRACKET
168	10-3469010101	CD PANEL	207	30-0756010101	FOOT RUBBER
169	10-3470010101	TAPE COVER (A)	209	46-0402-1	REFLECTION PAPER
170	10-3471010101	TAPE COVER (B)	211	10-3494010101	LED FILTER (A)
171	10-3472010101	TAPE COVER WINDOW (A)	212	10-3495010101	LED FILTER (B)
172	10-3473010101	TAPE COVER WINDOW (B)	213	10-3496010101	LED FILTER (C)
173	10-3474010101	TAPE HOLDER (A)	214	20-1136010101	PUSH LOCK SPRING
174	10-3475010101	TAPE HOLDER (B)	215	20-1133010101	TAPE HOLDER SPRING (A)
175	10-3476010101	DECK BUTTON	216	20-1134010101	TAPE HOLDER SPRING (B)
176	10-3482010101	CD BUTTON	501	34-0022-1	TN-2300T-122,CD MECHANISM
177	10-3477010101	REC BUTTON	502	31-0064-1	CRH-44-04(REC/PB),CASSETTE MECHANISM
178	10-3481010101	DISC BUTTON	503	31-0065-1	CRH-44-05(PB),CASSETTE MECHANISM
179	10-3446010101	FUNCTION BUTTON	504	10-3510010101	FLAT CABLE BUSHING
180	10-3446020101	FUNCTION BUTTON	LW601	12P15-0003	CFG1315-0101+FLAT,LEAD CONNECTOR ASS'Y
181	10-3480010101	RANDOM BUTTON	I W701	12-0157-1	AWM2896 BNC-D-P1.25x18.FFC -
182	10-3479010101	OPEN BUTTON	LW702	CL019 06-35	6P WHT,LEAD CONNECTOR ASS'Y
183	10-3483010101	DUMPER GEAR	LW703	CL019 08-25	8P RED,LEAD CONNECTOR ASS'Y
184	10-3484010101	DUMPER CASE	LW704	CL019 08-25	8P WHT,LEAD CONNECTOR ASS'Y
185	10-3485010101	PUSH LOCK	LW801	CL0412 6/7-18	6P-7P WHT,LEAD CONNECTOR ASS'Y
186	10-3486010101	PUSH LOCK HOLDER	LW802	CL041 03-18	3P WHT,LEAD CONNECTOR ASS'Y
187	10-3487010101	LIGHT GUIDE (A)			
188	10-3488010101	LIGHT GUIDE (B)			
189	10-3490010101	LED BOX (A)			
190	10-3491010101	LED BOX (B)			
191	10-3492010101	LED BOX (C)			
195	20-1127010101	BOTTOM COVER (A)			
196	20-1126010101	TOP COVER (A)			
197	20-1128010101	REAR COVER (A) <U>			
198	20-1128020101	REAR COVER (A) <A>			
199	20-1115010101	PCB BRACKET(A)			
200	20-1116010101	PCB BRACKET(B)			

<U> : U.S.A. model only  
<A> : Asian model only

-14-

# CASSETTE DECK MECHANISM EXPLODED VIEW

KCY-707

KCY-707

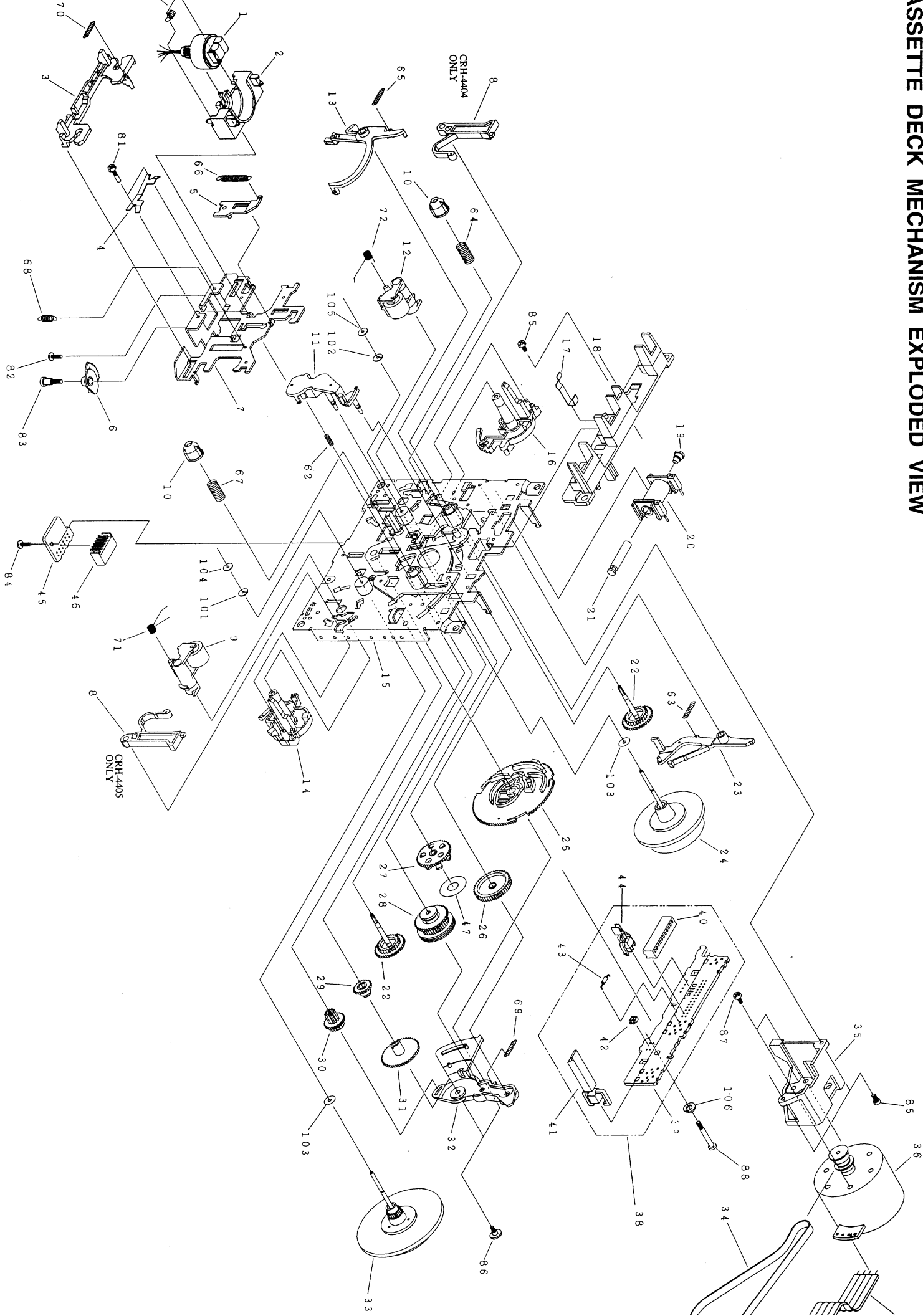



# CASSETTE DECK MECHANISM PARTS LIST

REF. NO.	PART NO.	DESCRIPTION	REF. NO.	PART NO.	DESCRIPTION
1	330934148	holder head ass'y <B>	47	330004140	reflector
	330934120	holder head ass'y <A>	61	10804535	spring
2	332193023	frame head	62	10814483	spring
3	332593015	lever head	63	10804480	spring
4	161604032	spring azimuth	64	10814493	spring
5	330934055	lever assist ass'y	65	10804482	spring
6	222394020	gear arm head	/66	10804489	spring
7	33112303	chassis head B	67	10814492	spring
8	332394024	eject lock	68	10804478	spring
9	330934060	arm pinch R ass'y	69	10804543	spring
10	182283231	cap reel	70	10804479	spring
11	332393012	arm UD	71	10824485	spring
12	330934059	arm pinch L ass'y	72	10824486	spring
13	332393014	arm brake	81	33004056	screw
14	332113019	frame B	82	GSL20A2008	screw
15	330933056	chassis ass'y	83	33004043	screw
16	332112020	frame C	84	GSE10A2004	screw
17	331604031	spring cassette	85	GSD20A2005	screw
18	332112021	frame D	86	33004344	screw
19	033194259	K. plunger	87	GSP11A2605	screw
20	330934051	coil ass'y	88	33004368	screw
21	033004338	plunger	101	GWN13X050040S	washer
22	332224009	gear reel	102	GWN13X060040S	washer
23	3322683013	arm trigger	103	GWP18X060050	washer
24	330934050	flywheel L ass'y	104	GWN16X40050	washer
25	332212010	gear cam	105	GWN15S040050	washer
26	332224008	gear idl	106	GWS30N	washer
27	332224007	gear ref			
28	330933045	clutch ass'y			
29	332224002	gear P			
30	332224001	gear A			
31	33222403	gear fr			
32	332393011	arm fr			
33	330934048	flywheel R ass'y			
34	020844124	belt			
35	332193025	bracket MM	<A> :	DECK-A(CRH-4405) ONLY	
36	330934104	motor ass'y	<B> :	DECK-B(CRH-4404) ONLY	
37	160724055	wire			
38	330933100	P.C.B. ass'y <B>			
	330933145	P.C.B. ass'y <A>			
39	330703035	P.C.B.			
40	HBRK11R-2	housing <B>			
	HBRK9R-2	housing <A>			
41	LSA1135 or MTS10041MVLO	switch (leaf)			
42	SG105 BC	photo sensor			
43	ERDS2TJ681	resistor			
44	MSW1722NCV	mode switch			
45	3307040615	P.C.B. head			
46	S6BEH	housing <B>			
	S3BEH	housing <A>			

CASSETTE DECK MECHANISM

# CD MECHANISM EXPLODED VIEW

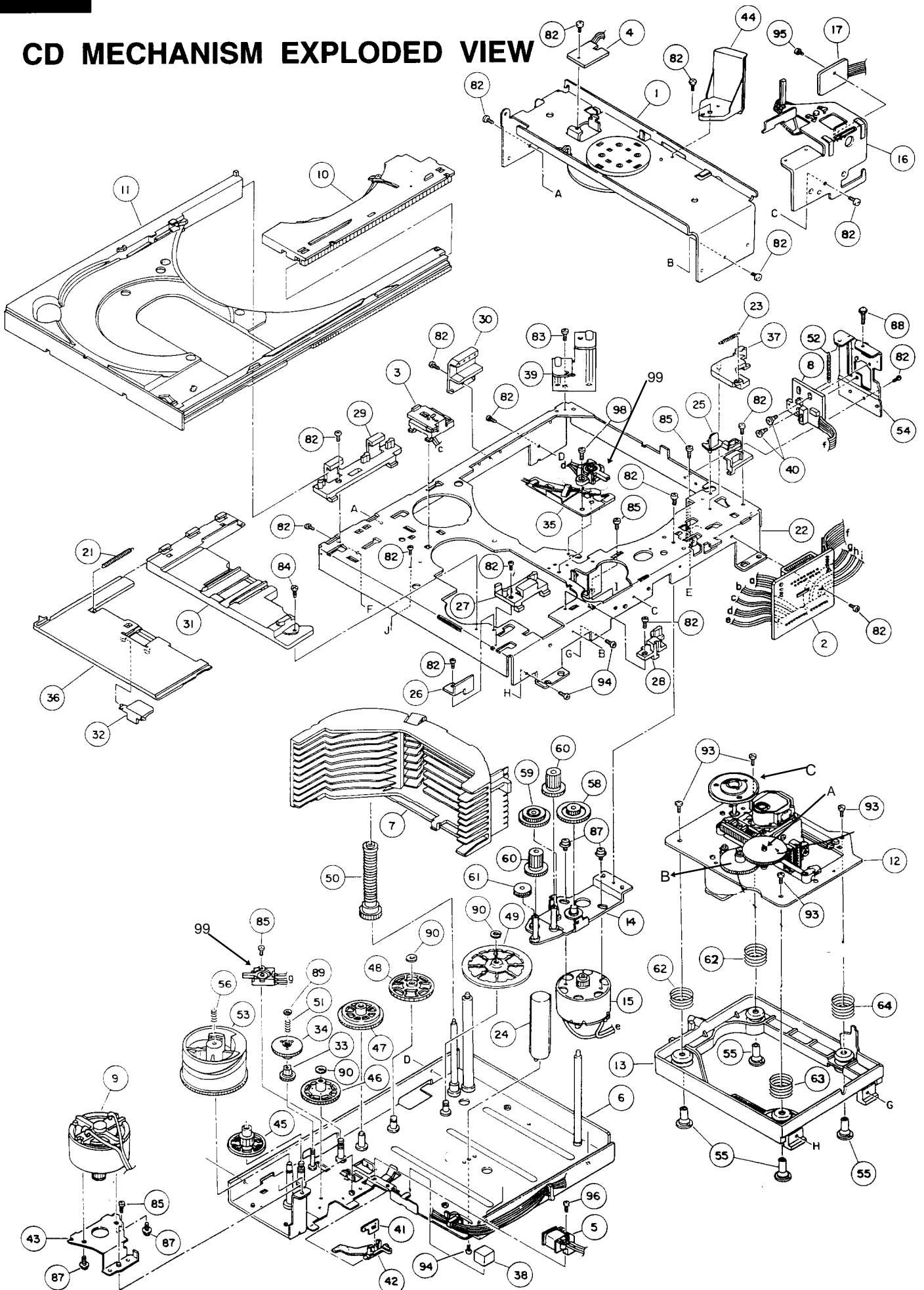

# CD MECHANISM PARTS LIST

REF. NO.	PART NO.	DESCRIPTION	REF. NO.	PART NO.	DESCRIPTION
1	300701316	clumper bracket ass'y	55	30070713	float rubber holder
2	300701306	connector PCB ass'y	56	30070283	E gear G4 spring
3	300701309	disc sensor PCB A ass'y	58	300701125	L gear B(N)
4	300701311	disc sensor PCB B ass'y	59	300701126	L gear C(N)
5	300702317	coil ass'y	60	30071105	L gear D
6	300702512	gear chassis ass'y	61	30071106	L gear E
7	300702318	disc case ass'y	62	30070766	floating spring NB
8	300702319	E sensor PCB ass'y	63	30070768	floating spring ND
9	300702302	E motor ass'y	64	30070767	floating spring NC
10	300706316	loading plate ass'y	82	9P0420041	tapping screw M2x4
11	300706317	disc base ass'y	83	9B1320041	C tapping bind screw M2x4
**12	69020301	traverse KSM-2102BAM	84	9P0420061	tapping screw M2x6
13	300707317	T.T. base holder ass'y	85	PC2020301	tapping screw SG M2x3
14	300711501	L gear bracket ass'y	87	9P03026221	cup screw M2.6x2.2
15	300711301	L motor ass'y	88	9P1720102	cup screw (+-)M2x10
16	300711306	guide plate aasy	89	9PW0250080	PW cut 1.85x5x0.5
17	300711304	L sensor PCB ass'y	90	9PW0250110	PW cut 2.6x6x0.5
21	30070187	cover plate spring(N)	93	9B1220041	P tapping bind screw M2x4
22	30070185	chassis(N)	94	9P0720061	P tapping screw M2x6
23	30070144	lock lever spring	95	9C0320353	camera screw M2x3.5
24	30070179	disc stopper D	96	9P0420101	tapping screw M2x10
25	30070186	guide R4	98	9P0420051	tapping screw M2.6x5
26	30070149	disc base bracket	99	25065375	Switch
27	30070150	guide R1(S)	A	24506903	Wheel A
28	30070151	guide R2(S)	B	24506904	Wheel B
29	30070153	guide L1(S)	C	24502258-1	Spindle Motor
30	30070106	guide L2	12	8-848-137-11	Traverse Assembly (Alternate PN#)
31	30070155	cover plate B(S)			
32	30070156	disc stopper(S)			
33	300702111	E gear G2(P)A			
34	30070256	E gear G2(S)B			
35	30070184	switch base			
36	30070162	cover plate A(S)			
37	30070163	locker lever(S)			
38	300702116	cushion rubber(P10)			
39	30070298	worm gear bracket(P10)			
40	19001204	coller screw			
41	30070296	E control plate(P)			
42	30070292	E control lever(P)			
43	300702100	E motor bracket(P10)			
44	30070175	guide stopper(P10)			
45	30070277	E gear G3(N)			
46	300702122	gear G5(TN)			
47	30070279	gear G6(N)			
48	300702113	gear G7(P10)			
49	30070293	gear G8(P10)			
50	300702112	E gear G9(P10)			
51	30070232	E gear G2 spring			
52	300702119	E sensor spring T			
53	30070259	E gear G4(S)			
54	30070297	E sensor bracket(P10)			

# PRINTED CIRCUIT BOARD PART LIST

CIRCUIT NO.	PART NO.	DESCRIPTION	CIRCUIT NO.	PART NO.	DESCRIPTION
<b>MAIN CIRCUIT PC BOARD</b>					
	<b>IC</b>		C605	354753329	25V3300 $\mu$ F
IC602	222780053 or 1-0185-1	NJM78L05	C618	3000079	5.5V0.22F
IC603	222780091 or 1-0138-1	NJM78M09		<b>TRIMER RESISTOR</b>	
IC604	1-0311-1	CXP84124-136Q	VR701,702,801,802	5210068	47K $\Omega$
IC605	22240328 or 1-0207-1	BU4052BC	VR803-806	5210064	10K $\Omega$
IC701	1-0302-1	CXA1782BQ	VR807,808	5210066	22K $\Omega$
IC702	1-0303-1	CXD2508AQ	VR809,811-812	5210062	4.7K $\Omega$
IC703	222652 or 1-0281-1	M5218L		<b>SOCKET</b>	
IC704	1-0304-1	BA6398FP	J701	12-0151-1	CFF1118-0101 or HILEM18S-1
IC705	1-0306-1	BA6247	J702	12S6-J0001	B6B-PH
IC801	22240147 or 1-0309-1	$\mu$ PC1330HA	J703,704	12S8-J0001	B8B-PH
IC802	1-0307-1	BA3442BKS	J801	12S7-J0001	B7B-EH
IC803	22240086 or 1-0308-1	CXA1101P	J802	12S3-J0001	B3B-EH
	<b>TRANSISTOR</b>		J805	12S6-C0002	52147-0610
Q601,603,607	2202705 or 2-2SD2394E-7	2SD2394E	J806	12S3-C0002	52147-0310
Q602,604,606,608, Q704,705,709,804, Q805,806,807,815, Q820,823,824	2213284 or 2-2SC1740S-S7	2SC1740SR	J807	12S8-C0002	52147-0810
Q605	2213355 or 2-2SA933S-S7	2SA933AS		<b>FLAT CABLE</b>	
Q609,610,611	2-2SB1333-7	2SB1333	LW803	12-0177-1	UL2651#26 $\times$ 9
Q613-617,703,707, Q801,802,808,809, Q812,817	2213160 or 2-DTC124ES-7	DTC124ES	LW804	12-0178-1	UL2651#26 $\times$ 11
Q701,810	2-2SA1585SQ-7	2SA1585SQ	LW808	12-0171-1	UL2651#26 $\times$ 6
Q702,706,803,825	2212600 or 2-DTA124ES-7	DTA124ES		<b>OTHERS</b>	
Q708,814,819	2-2SB1374Q-7	2SB1374Q	E600	20-1132010101	HEAT SINK(C)
Q811	2-2SD2172-7	2SD2172	<b>CONTROL CIRCUIT PC BOARD</b>		
Q813,816,818,821	2-2SC1741S-7	2SC1741S	<b>IC</b>		
	<b>FET</b>		IC606	1-0319-1	BU2092F
Q710,711	2212195	2SK241GR		<b>DIODE</b>	
	<b>ZENER DIODE</b>		D614,615,616,617	223163 or 3-1SS133-1	1SS133
D605	3-Z-MTZJ10B-8	MTZJ10B		<b>LED</b>	
D606	3-Z-MTZJ5.6B8	MTZJ5.6B	LED601,602	28-0063-1	SLR332MG
D607	3-Z-MTZJ13B-8	MTZJ13B	LED603,604,607,608, LED611-613,615,617, LED619,621,623,625, LED627,629,631,633, LED634	28-0057-1	SLV-312VC
D609,610,611	3-Z-MTZJ8.2B8	MTZJ8.2B	LED605,606	28-0062-1	SLR332VR
	<b>DIODE</b>		LED609,610,614,616, LED618,620,622,624, LED626,628,630,632, LED635,636	28-0058-1	SLV-312MC
D608	3-RB100A	RB100A		<b>TACT SWITCH</b>	
D612	223839	1N4002	SW601-611,614-632	8-0263-2	SKHHAM
	<b>CERAMIC RESONATOR</b>		SW612,613	8-0269-1	SKHHIAR
X601	29-0069-1	CST8MTW		<b>FLAT CABLE</b>	
X701	29-0085-1	CSA33.86MXZ040	LW805	12-0174-1	UL2651#26 $\times$ 6
	<b>COIL</b>		LW806	12-0163-1	UL2651#26 $\times$ 3
L801,802	6-0310-1	10RB type,39mH	LW807	12-0176-1	UL2651#26 $\times$ 8
L803	CHNS-6010	10PA type		<b>MICRO INDUCTOR</b>	
L601,701	26-0012-2	LAL03,10 $\mu$ H			
L602	26-0056-1	LAL03,100 $\mu$ H			

**LOCK DIAGRAM**

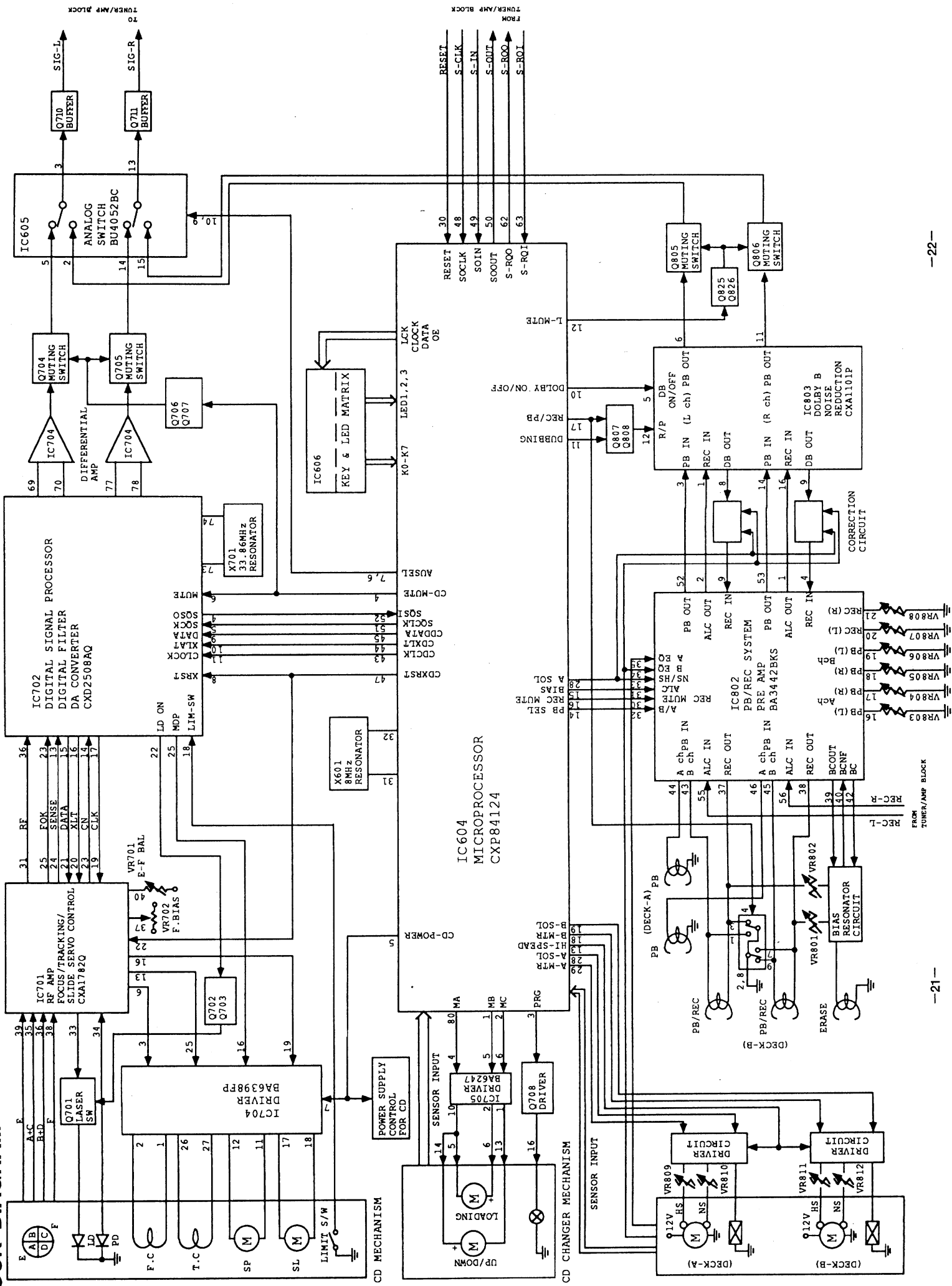

SCHEMATIC DIAGRAM

A B C D E F G

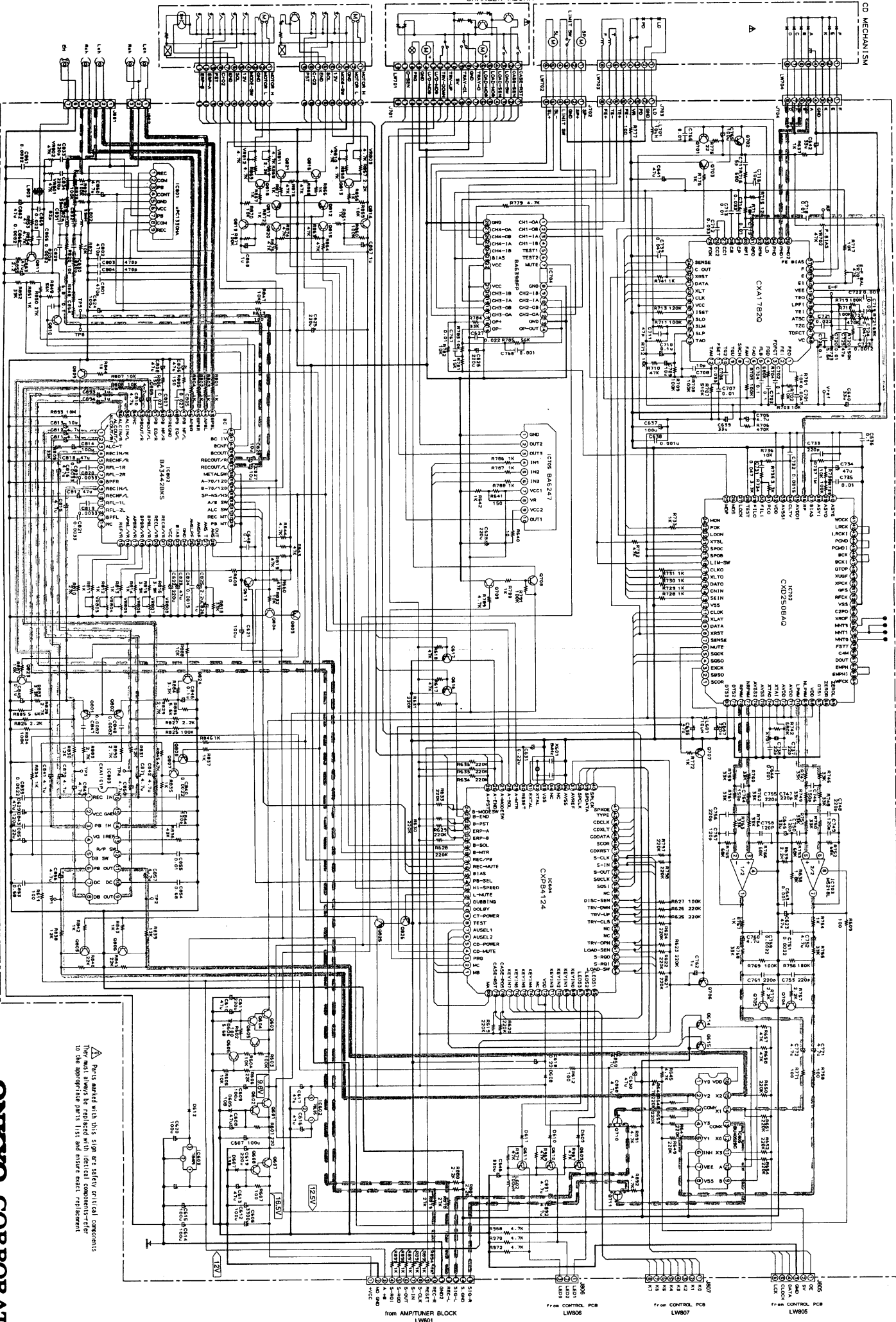

△ Parts marked with this sign are safety critical components  
 To be replaced only by identical components  
 To the appropriate parts list and their serial numbers

from AMP/TUNER BLOCK LW801  
 CONTROL PCB LW806  
 CONTROL PCB LW807  
 CONTROL PCB LW808

