

Comfort Glow®

VENT-FREE NATURAL GAS RADIANT FLAME® HEATER OWNER'S OPERATION AND INSTALLATION MANUAL

RFN28TD

15,000 to 28,000 Btu/Hr
with Thermostat

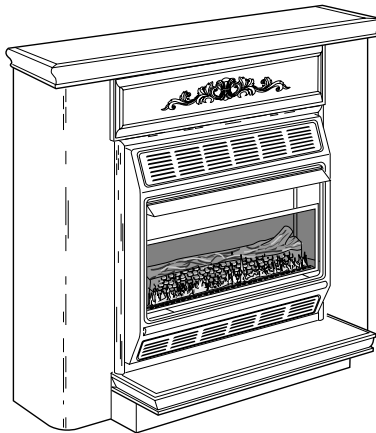

Shown with Optional
Mantel featuring
Built-in Base

WARNING: If the information in this manual is not followed exactly, a fire or explosion may result causing property damage, personal injury, or loss of life.

- Do not store or use gasoline or other flammable vapors and liquids in the vicinity of this or any other appliance.
- **WHAT TO DO IF YOU SMELL GAS**
 - Do not try to light any appliance.
 - Do not touch any electrical switch; do not use any phone in your building.
 - Immediately call your gas supplier from a neighbor's phone. Follow the gas supplier's instructions.
 - If you cannot reach your gas supplier, call the fire department.
- Installation and service must be performed by a qualified installer, service agency, or the gas supplier.

WARNING: Improper installation, adjustment, alteration, service, or maintenance can cause injury or property damage. Refer to this manual for correct installation and operational procedures. For assistance or additional information consult a qualified installer, service agency, or the gas supplier.

WARNING: This is an unvented gas-fired heater. It uses air (oxygen) from the room in which it is installed. Provisions for adequate combustion must be provided. Refer to *Air For Combustion and Ventilation* section on page 5 of this manual.

This appliance may be installed in an aftermarket* manufactured (mobile) home, where not prohibited by state or local codes.

* Aftermarket: Completion of sale, not for purpose of resale, from the manufacturer

This appliance is only for use with the type of gas indicated on the rating plate.
This appliance is not convertible for use with other gases.

Save this manual for future reference.

Comfort Glow® 15,000 TO 28,000 BTU/HR VENT-FREE NATURAL GAS HEATER

SAFETY INFORMATION

WARNINGS

IMPORTANT: Read this owner's manual carefully and completely before trying to assemble, operate, or service this heater. Improper use of this heater can cause serious injury or death from burns, fire, explosion, electrical shock, and carbon monoxide poisoning.

 DANGER: Carbon monoxide poisoning may lead to death!

Carbon Monoxide Poisoning: Early signs of carbon monoxide poisoning resemble the flu, with headaches, dizziness, or nausea. If you have these signs, the heater may not be working properly. **Get fresh air at once!** Have heater serviced. Some people are more affected by carbon monoxide than others. These include pregnant women, people with heart or lung disease or anemia, those under the influence of alcohol, and those at high altitudes.

Natural Gas: Natural gas is odorless. An odor-making agent is added to natural gas. The odor helps you detect a natural gas leak. However, the odor added to natural gas can fade. Natural gas may be present even though no odor exists.

Make certain you read and understand all warnings. Keep this manual for reference. It is your guide to safe and proper operation of this heater.

 WARNING: Any change to this heater or its controls can be dangerous.

1. Use only natural gas. Do not convert heater to use different fuel type.
2. If you smell gas
 - shut off gas supply
 - do not try to light any appliance
 - do not touch any electrical switch; do not use any phone in your building.
 - immediately call your gas supplier from a neighbor's phone. Follow the gas supplier's instructions
 - if you cannot reach your gas supplier, call the fire department
3. This heater shall not be installed in a bedroom or bathroom.
4. Never install the heater
 - in a recreational vehicle
 - where curtains, furniture, clothing, or other flammable objects are less than 36 inches from the front, top, or sides of the heater
 - as a fireplace insert
 - in high traffic areas
 - in windy or drafty areas
5. This heater needs fresh, outside air ventilation to run properly. This heater has an oxygen depletion sensor (ODS) pilot light safety system. The ODS shuts down the heater if not enough fresh air is available. See *Air for Combustion and Ventilation*, pages 5 through 7.
6. Before using furniture polish, wax, carpet cleaner, or similar products, turn heater off. If heated, the vapors from these products may create a white powder residue within burner box or on adjacent walls or furniture.
7. If heater shuts off, do not relight until you provide fresh, outside air. If heater keeps shutting off, have it serviced.
8. Do not run heater
 - where flammable liquids or vapors are used or stored.
 - under dusty conditions.
9. Never place any objects on the heater.
10. Surface of heater becomes very hot when running heater. Keep children and adults away from hot surface to avoid burns or clothing ignition. Heater will remain hot for a time after shutdown. Allow surface to cool before touching.
11. Carefully supervise young children when they are in same room with heater.
12. Make sure screen is in place before running heater.
13. Do not use heater if any part has been under water. Immediately call a qualified service technician to inspect the room heater and to replace any part of the control system and any gas control which has been under water.
14. Turn off and unplug heater and let cool before servicing. Only a qualified service person should service and repair heater.
15. Operating heater above elevations of 4,500 feet may cause pilot outage.

 WARNING: Do not use a blower insert, heat exchanger insert, or other accessory not approved for use with this heater.

OWNER'S MANUAL

PRODUCT IDENTIFICATION

PRODUCT FEATURES

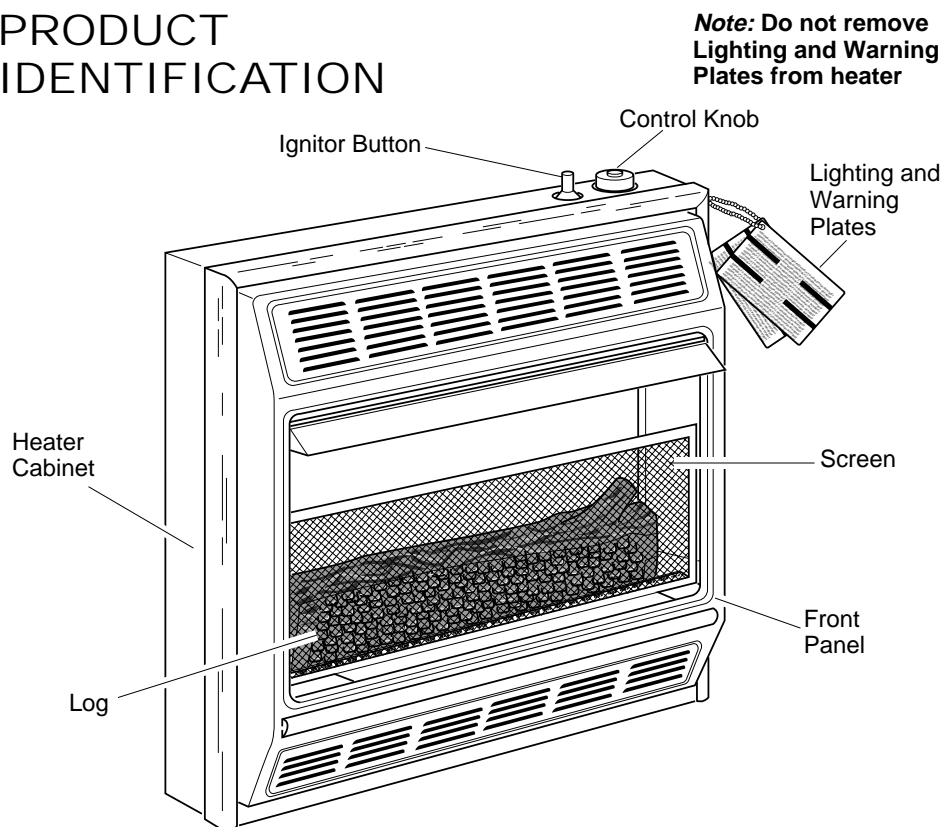

Safety Pilot

This heater has a pilot with an Oxygen Depletion Sensor Shutoff System (ODS). The ODS/pilot is a required feature for vent-free room heaters. The ODS/pilot shuts off the heater if there is not enough fresh air.

Piezo Ignition System

This heater has a piezo ignitor. This system requires no matches, batteries, or other sources to light heater.

Thermostatic Heat Control

This heater has a thermostat sensing bulb and a control valve. This results in the greatest heater comfort. This can also result in lower gas bills.

Figure 1 - Vent-Free Gas Log Natural Gas Space Heater

LOCAL CODES

Install and use heater with care. Follow all local codes. In the absence of local codes, use the latest edition of *The National Fuel Gas Code ANSI Z223.1*, also known as NFPA 54*.

*Available from:

American National Standards Institute, Inc.
1430 Broadway
New York, NY 10018

National Fire Protection Association, Inc.
Batterymarch Park
Quincy, MA 02269

UNPACKING

1. Remove heater from carton.
2. Remove all protective packaging applied to heater for shipment.
3. Make sure your heater includes two hardware packets.
4. Check heater for any shipping damage. If heater is damaged, promptly inform dealer where you bought heater.

Comfort Glow® 15,000 TO 28,000 BTU/HR VENT-FREE NATURAL GAS HEATER

ASSEMBLY

ASSEMBLING HEATER

Tools Required:

- Phillips screwdriver
- 5/16" hex wrench
- slotted screwdriver

Removing Front Panel Of Heater

1. Remove two screws near bottom corners of front panel with Phillips screwdriver.
2. Pull bottom of front panel forward, then down (see Figure 2).

Installing Log

Note: For easier installation, lay heater on its back.

1. Remove log from inside top of heater. Discard protective packaging.
2. Attach ignitor cable to piezo ignitor (see Figure 3).
3. With Phillips screwdriver, remove four screws holding screen in place. Remove screen.
4. Gently slide log between log retaining brackets on deflector assembly (see Figure 4). The log should fit firmly against bottom of log retaining brackets.
5. Reattach screen using four screws removed in step 3.

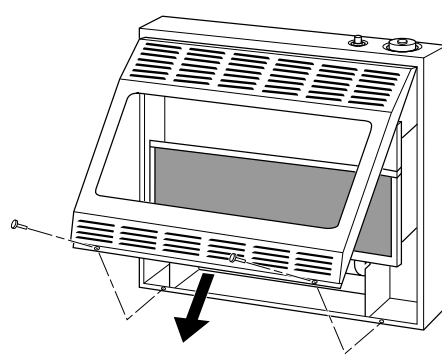

Figure 2 - Removing Front Panel of Heater

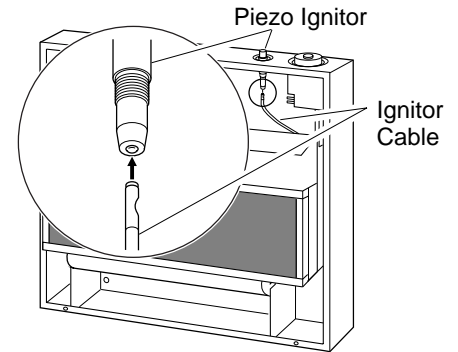

Figure 3 - Attaching Ignitor Cable to Piezo Ignitor

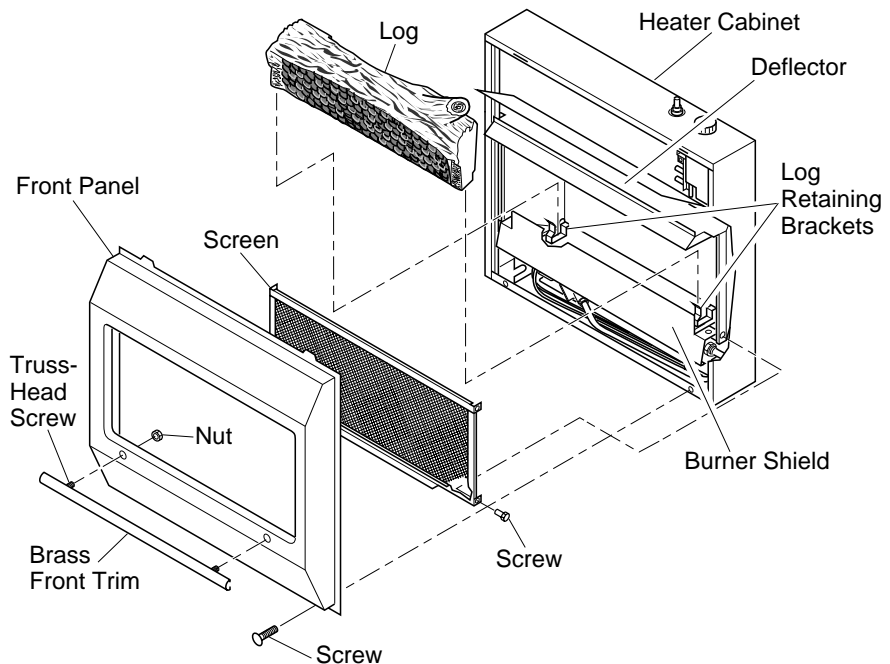

Figure 4 - Assembling Heater

Attaching Brass Front Trim to Front Panel

1. Locate brass front trim in brass trim package.
2. Slide the head of two truss-head screws from hardware packet into each end of brass front trim (see Figure 5).
3. Line up screws with holes in front panel (see Figure 4). Insert screws in holes. Attach nuts from inside of front panel. Tighten with wrench.

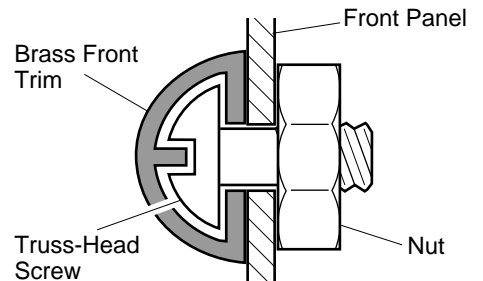

Figure 5 - Attaching Brass Front Trim to Front Panel

⚠ WARNING: Always have burner shield and screen in place before operating heater. This prevents excessive temperatures on heater surfaces.

Failure to position the parts in accordance with these diagrams or failure to use only parts specifically approved with this heater may result in property damage or personal injury.

ASSEMBLY

Continued

Assembling and Attaching Brass Trim

1. Remove packaging from remaining three pieces of brass trim.
2. Locate four brass screws, two adjusting plates with set screws, and two shims in the hardware packet.
3. Align shim under adjusting plate as shown in Figure 6.
4. Slide one end of adjusting plate/shim in slot on mitered edge of top brass trim (see Figure 6).
5. Slide other end of adjusting plate/shim in slot on mitered edge of side brass trim (see Figure 6).
6. While firmly holding edges of brass trim together, tighten both set screws on the adjusting plate with slotted screwdriver.
7. Repeat steps 1 through 6 for other side.
8. Place the assembled trim on front of heater cabinet. Attach on top and sides with four brass screws included in hardware package (see Figure 7).
9. Reattach front panel to heater if you are going to mount the heater to the base. Do not reattach front panel at this time if you are going to mount heater to wall.

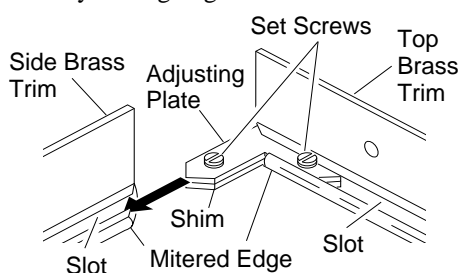

Figure 6 - Assembling Brass Trim

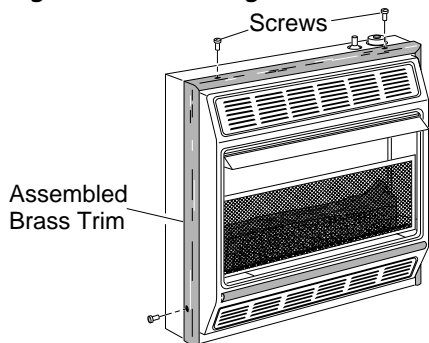

Figure 7 - Attaching Brass Trim to Heater

AIR FOR COMBUSTION AND VENTILATION

⚠ WARNING: This heater shall not be installed in a confined space unless provisions are provided for adequate combustion and ventilation air. Read the following instructions to insure proper fresh air for this and other fuel-burning appliances in your home.

Today's homes are built more energy efficient than ever. New materials, increased insulation, and new construction methods help reduce heat loss in homes. Home owners weather strip and caulk around windows and doors to keep the cold air out and the warm air in. During heating months, home owners want their homes as airtight as possible.

While it is good to make your home energy efficient, your home needs to breathe. Fresh air must enter your home. All fuel-burning appliances need fresh air for proper combustion and ventilation.

Exhaust fans, fireplaces, clothes dryers, and fuel burning appliances draw air from the house to operate. You must provide adequate fresh air for these appliances. This will insure proper venting of vented fuel-burning appliances.

PROVIDING ADEQUATE VENTILATION

The following is excerpts from *National Fuel Gas Code, NFPA 54/ANSI Z223.1, Section 5.3, Air for Combustion and Ventilation*.

All spaces in homes fall into one of the three following ventilation classifications:

1. Unusually Tight Construction
2. Unconfined Space
3. Confined Space

The information on pages 5 through 7 will help you classify your space and provide adequate ventilation.

Unusually Tight Construction

The air that leaks around doors and windows may provide enough fresh air for combustion and ventilation. However, in

buildings of unusually tight construction, you must provide additional fresh air.

Unusually tight construction is defined as construction where:

- a. walls and ceilings exposed to the outside atmosphere have a continuous water vapor retarder with a rating of one perm (6×10^{-11} kg per pa-sec- m^2) or less with openings gasketed or sealed and
- b. weather stripping has been added on openable windows and doors and
- c. caulking or sealants are applied to areas such as joints around window and door frames, between sole plates and floors, between wall-ceiling joints, between wall panels, at penetrations for plumbing, electrical, and gas lines, and at other openings.

If your home meets all of the three criteria above, you must provide additional fresh air. See *Ventilation Air From Outdoors*, page 7.

If your home does not meet all of the three criteria above, proceed to *Determining Fresh-Air Flow for Heater Location*, page 6.

Confined and Unconfined Space

The National Fuel Gas Code (ANSI Z223.1, 1992 Section 5.3) defines a confined space as a space whose volume is less than 50 cubic feet per 1,000 Btu per hour (4.8 m^3 per kw) of the aggregate input rating of all appliances installed in that space and an unconfined space as a space whose volume is not less than 50 cubic feet per 1,000 Btu per hour (4.8 m^3 per kw) of the aggregate input rating of all appliances installed in that space. Rooms communicating directly with the space in which the appliances are installed*, through openings not furnished with doors, are considered a part of the unconfined space.

This heater shall not be installed in a confined space or unusually tight construction unless provisions are provided for adequate combustion and ventilation air.

* Adjoining rooms are communicating only if there are doorless passageways or ventilation grills between them.

Continued

Comfort Glow® 15,000 TO 28,000 BTU/HR VENT-FREE NATURAL GAS HEATER

AIR FOR COMBUSTION AND VENTILATION

Continued

DETERMINING FRESH-AIR FLOW FOR HEATER LOCATION

Determining if You Have a Confined or Unconfined Space

Use this worksheet to determine if you have a confined or unconfined space.

Space: Includes the room in which you will install heater plus any adjoining rooms with doorless passageways or ventilation grills between the rooms.

1. Determine the volume of the space (length x width x height).

Length x Width x Height = _____ cu. ft. (volume of space)

Example: Space size 20 ft. (length) x 16 ft. (width) x 8 ft. (ceiling height) = 2560 cu. ft. (volume of space)

If additional ventilation to adjoining room is supplied with grills or openings, add the volume of these rooms to the total volume of the space.

2. Divide the space volume by 50 cubic feet to determine the maximum Btu/Hr the space can support.

_____ (volume of space) ÷ 50 cu. ft. = (Maximum Btu/Hr

the space can support)

Example: 2560 cu. ft. (volume of space) ÷ 50 cu. ft. = 51.2 or 51,200 (maximum Btu/Hr the space can support)

3. Add the Btu/Hr of all fuel burning appliances in the space.

Vent-free heater _____ Btu/Hr

Gas water heater* _____ Btu/Hr

Gas furnace _____ Btu/Hr

Vented gas heater _____ Btu/Hr

Gas fireplace logs _____ Btu/Hr

Other gas appliances* + _____ Btu/Hr

Total = _____ Btu/Hr

Example:

| | | |
|------------------|--------|--------|
| Gas water heater | 30,000 | Btu/Hr |
|------------------|--------|--------|

| | | |
|------------------|----------|--------|
| Vent-free heater | + 28,000 | Btu/Hr |
|------------------|----------|--------|

| | | |
|-------|----------|--------|
| Total | = 58,000 | Btu/Hr |
|-------|----------|--------|

* Do not include direct-vent gas appliances. Direct-vent draws combustion air from the outdoors and vents to the outdoors.

4. Compare the maximum Btu/Hr the space can support with the actual amount of Btu/Hr used.

_____ Btu/Hr (maximum the space can support)

_____ Btu/Hr (actual amount of Btu/Hr used)

Example: 51,200 Btu/Hr (maximum the space can support)

58,000 Btu/Hr (actual amount of Btu/Hr used)

The space in the above example is a confined space because the actual Btu/Hr used is more than the maximum Btu/Hr the space can support. You must provide additional fresh air. Your options are as follows:

- A. Rework worksheet, adding the space of an adjoining room. If the extra space provides an unconfined space, remove door to adjoining room or add ventilation grills between rooms. See *Ventilation Air From Inside Building*, page 7.
- B. Vent room directly to the outdoors. See *Ventilation Air From Outdoors*, page 7.
- C. Install a lower Btu/Hr heater, if lower Btu/Hr size makes room unconfined.

If the actual Btu/Hr used is less than the maximum Btu/Hr the space can support, the space is an unconfined space. You will need no additional fresh air ventilation.

⚠ WARNING: If the area in which the heater may be operated is smaller than that defined as an unconfined space or if the building is of unusually tight construction, provide adequate combustion and ventilation air by one of the methods described in the *National Fuel Gas Code, ANSI Z223.1, 1992, Section 5.3* or applicable local codes.

AIR FOR COMBUSTION AND VENTILATION

Continued

VENTILATION AIR

Ventilation Air From Inside Building

This fresh air would come from an adjoining unconfined space. When ventilating to an adjoining unconfined space, you must provide two permanent openings: one within 12" of the ceiling and one within 12" of the floor on the wall connecting the two spaces (see options 1 and 2, Figure 8). You can also remove door into adjoining room (see option 3, Figure 8). Follow the *National Fuel Gas Code NFPA 54/ANSI Z223.1, Section 5.3, Air for Combustion and Ventilation* for required size of ventilation grills or ducts.

⚠ WARNING: Rework worksheet, adding the space of the adjoining unconfined space. The combined spaces must have enough fresh air to supply all appliances in both spaces.

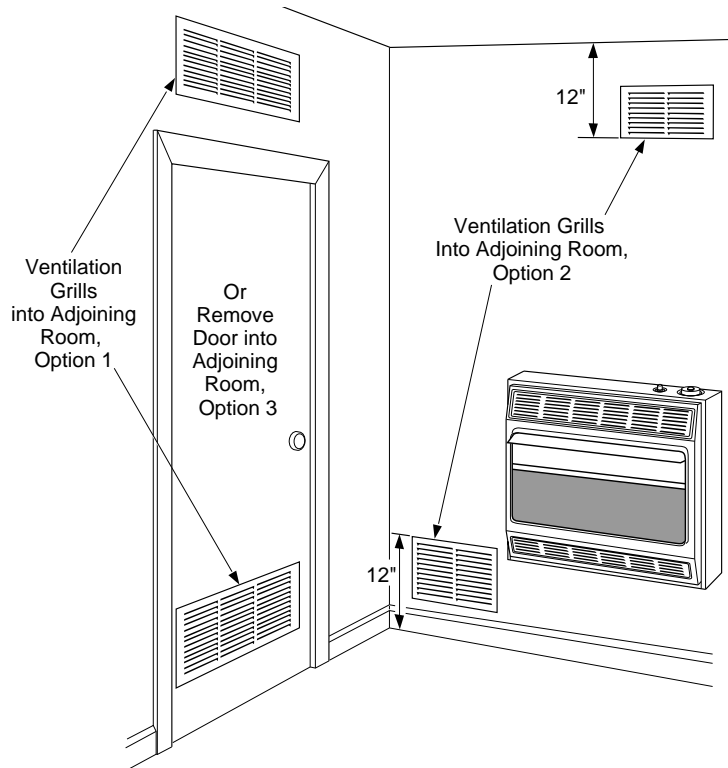

Figure 8 - Ventilation Air from Inside Building

Ventilation Air From Outdoors

Provide extra fresh air by using ventilation grills or ducts. You must provide two permanent openings: one within 12" of the ceiling and one within 12" of the floor. Connect these items directly to the outdoors or spaces open to the outdoors. These spaces include attics and crawl spaces. Follow the *National Fuel Gas Code NFPA 54/ANSI Z223.1, Section 5.3, Air for Combustion and Ventilation* for required size of ventilation grills or ducts.

IMPORTANT: Do not provide openings for inlet or outlet air into attic if attic has a thermostat-controlled power vent. Heated air entering the attic will activate the power vent.

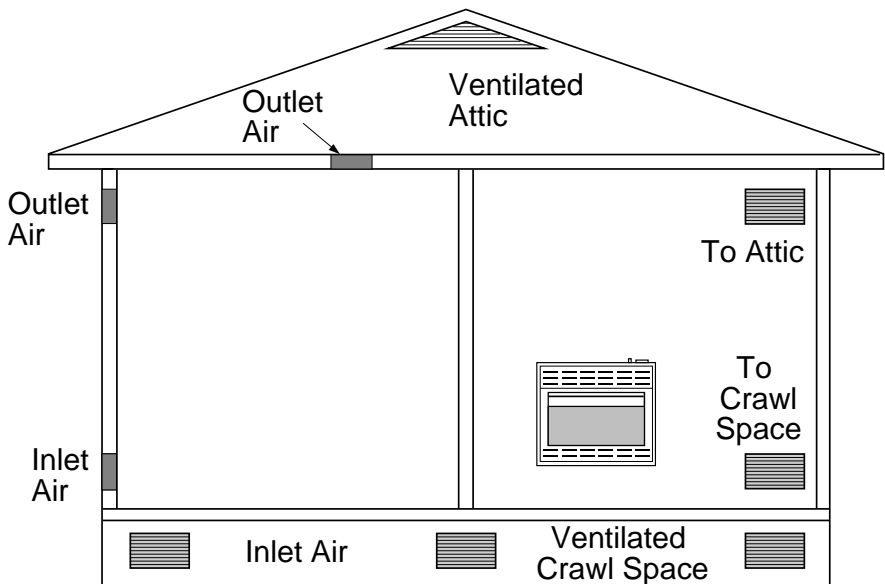

Figure 9 - Ventilation Air from Outdoors

Comfort Glow® 15,000 TO 28,000 BTU/HR VENT-FREE NATURAL GAS HEATER

INSTALLATION

NOTICE: This heater is intended for use as supplemental heat. Use this heater along with your primary heating system. Do not install this heater as your primary heat source. If you have a central heating system, you may run system's circulating blower while using heater. This will help circulate the heat throughout the house. In the event of a power outage, you can use this heater as your primary heat source.

NOTICE: A qualified service person must install heater. Follow all local codes.

CHECK GAS TYPE

Use only natural gas. If your gas supply is not natural gas, do not install heater. Call dealer where you bought heater for proper type heater.

INSTALLATION ITEMS

Before installing heater, make sure you have the items listed below.

- piping (check local codes)
- sealant (resistant to propane/LP gas)
- manual shutoff valve *
- ground joint union
- test gauge connection *
- sediment trap
- tee joint
- pipe wrench

* An A.G.A. design-certified manual shutoff valve with 1/8" NPT tap is an acceptable alternative to test gauge connection. Purchase the optional A.G.A. design-certified manual shutoff valve from your dealer. See *Accessories*, page 21.

LOCATING HEATER

WARNING: Maintain the minimum clearances shown in Figure 10. If you can, provide greater clearances from floor, ceiling, and joining wall.

You can locate heater on floor. The optional hearth base is needed. You can also install the optional decorative mantel on the heater (some mantels require hearth base).

IMPORTANT: Only use optional mantel and hearth base specified in this manual. Purchase the optional mantel and hearth base from your dealer. See *Accessories*, page 21.

The heater may also be mounted on a wall. You cannot use optional mantel if mounting heater on a wall.

WARNING: Never install the heater

- in a bedroom or bathroom
- in a recreational vehicle
- where curtains, furniture, clothing, or other flammable objects are less than 36 inches from the front, top, or sides of the heater
- as a fireplace insert
- in high traffic areas
- in windy or drafty areas

CAUTION: This heater creates warm air currents. These currents move heat to wall surfaces next to heater. Installing heater next to vinyl or cloth wall coverings or operating heater where impurities (such as tobacco smoke, aromatic candles, cleaning fluids, oil or kerosene lamps, etc.) in the air exist, may discolor walls.

IMPORTANT: Vent-free heaters add moisture to the air. Although this is beneficial, installing heater in rooms without enough ventilation air may cause mildew to form from too much moisture. See *Air for Combustion and Ventilation*, pages 5 through 7.

CAUTION: If you install the heater in a home garage

- heater pilot and burner must be at least 18 inches above floor.
- locate heater where moving vehicle will not hit it.

For convenience and efficiency, install heater

- where there is easy access for operation, inspection, and service.
- in coldest part of room.

An optional fan kit is available from your dealer. See *Accessories*, page 21. If planning to use fan, locate heater near an electrical outlet.

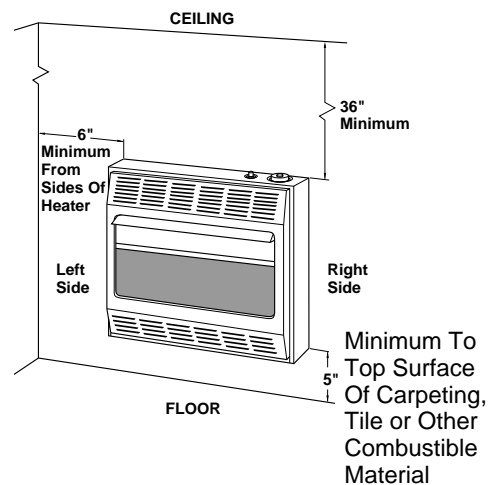

Figure 10 - Mounting Clearances As Viewed From Front of Heater

INSTALLATION

Continued

THERMOSTAT SENSING BULB

The thermostat sensing bulb has been placed inside the heater for protection during shipping.

Locating Thermostat Sensing Bulb

1. Remove front panel of heater (see Figure 2, page 4).
2. Locate thermostat sensing bulb just under burner assembly.

IMPORTANT: Attach thermostat sensing bulb to back of heater for proper operation.

Attaching Thermostat Sensing Bulb

1. Remove thermostat sensing bulb from holders inside heater. Route through slot opening in bottom of heater.
2. Place clamp on thermostat sensing bulb as shown in Figure 11. Clamp is provided in hardware package.
3. Snap clamp into upper mounting hole as shown in Figure 11. Mounting hole is located on lower left edge on back of heater. Make sure the thermostat sensing bulb is pointing up.

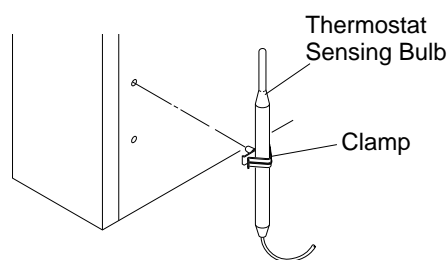

Figure 11 - Attaching Thermostat Sensing Bulb

INSTALLATION OPTIONS

There are three options for mounting this heater.

- A. Mounting heater to wall
- B. Mounting heater to optional hearth base
- C. Mounting heater with optional hearth base to optional mantel

A. MOUNTING HEATER TO WALL

Mounting Bracket

The mounting bracket is located on back panel of heater. It has been taped there for shipping. Remove mounting bracket from back panel.

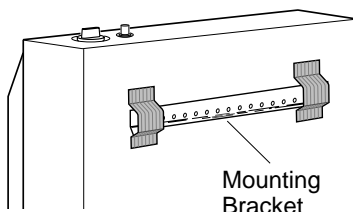

Figure 12 - Mounting Bracket Location

Methods For Attaching Mounting Bracket To Wall

Only use last hole on each end of mounting bracket to attach bracket to wall. These two holes are 16 inches apart from their centers. Attach mounting bracket to wall in one of two ways.

1. Attaching to wall stud
2. Attaching to wall anchor

Attaching to wall stud This method provides the strongest hold. Insert mounting screws through mounting bracket and into wall studs.

Attaching to wall anchor This method allows you to attach mounting bracket to hollow walls (wall areas between studs) or to solid walls (concrete or masonry).

Decide which method better suits your needs. Either method will provide a secure hold for the mounting bracket.

Marking Screw Locations

1. Tape mounting bracket to wall where heater will be located. Make sure mounting bracket is level.

WARNING: Maintain minimum clearances shown in Figure 13. If you can, provide greater clearances from floor and joining wall.

2. Mark screw locations on wall (see Figure 13).

Note: Only mark last hole on each end of mounting bracket. Insert mounting screws through these holes only.

3. Remove tape and mounting bracket from wall.

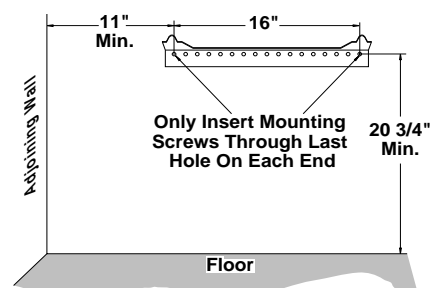

Figure 13 - Mounting Bracket Clearances

Comfort Glow® 15,000 TO 28,000 BTU/HR VENT-FREE NATURAL GAS HEATER

INSTALLATION

Continued

Attaching Mounting Bracket To Wall

Note: Wall anchors, mounting screws, and spacers are in hardware package. The hardware package is provided with heater.

Attaching to wall stud method

For attaching mounting bracket to wall studs

1. Drill holes at marked locations using 9/64" drill bit.
2. Place mounting bracket onto wall. Line up last hole on each end of bracket with holes drilled in wall.
3. Insert mounting screws through bracket and into wall studs.
4. Tighten screws until mounting bracket is firmly fastened to wall studs.

Attaching to wall anchor method

For attaching mounting bracket to hollow walls (wall areas between studs) or solid walls (concrete or masonry)

1. Drill holes at marked locations using 5/16" drill bit. For solid walls (concrete or masonry), drill at least 1" deep.
2. Fold wall anchor as shown in Figure 14.
3. Insert wall anchor (wings first) into hole. Tap anchor flush to wall.
4. For thin walls (1/2" or less), insert red key into wall anchor. Push red key to "pop" open anchor wings.
IMPORTANT: Do not hammer key!
For thick walls (over 1/2" thick) or solid walls, do not pop open wings.
5. Place mounting bracket onto wall. Line up last hole on each end of bracket with wall anchors.
6. Insert mounting screws through bracket and into wall anchors.
7. Tighten screws until mounting bracket is firmly fastened to wall.

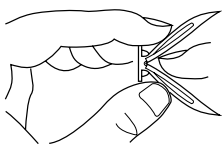

Figure 14 - Folding Anchor

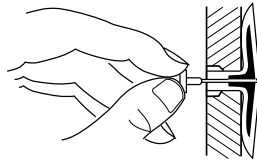

Figure 15 - Popping Open Anchor Wings For Thin Walls

Placing Heater On Mounting Bracket

1. Locate two horizontal slots on back panel of heater.
2. Place heater onto mounting bracket. Slide horizontal slots onto stand-out tabs on mounting bracket.

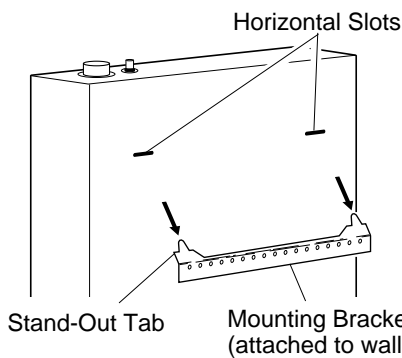

Figure 16 - Mounting Heater Onto Mounting Bracket

Installing Bottom Mounting Screws

1. Locate two bottom mounting holes. These holes are near bottom on back panel of heater (see Figure 17).
2. Mark screw locations on wall.
3. Remove heater from mounting bracket.
4. If installing bottom mounting screws into hollow or solid wall, install wall anchors. Follow steps 1 through 4 under *Attaching To Wall Anchor Method*. If installing bottom mounting screw into wall stud, drill holes at marked locations using 9/64" drill bit.
5. Replace heater onto mounting bracket.
6. Place spacers between bottom mounting holes and wall anchor or drilled hole.
7. Hold spacer in place with one hand. With other hand, insert mounting screw through bottom mounting hole and spacer. Place tip of screw in opening of wall anchor or drilled hole.

8. Tighten both screws until heater is firmly secured to wall. Do not over tighten.

Note: Do not replace front panel at this time. Replace front panel after making gas connections and checking for leaks (see pages 12 and 13).

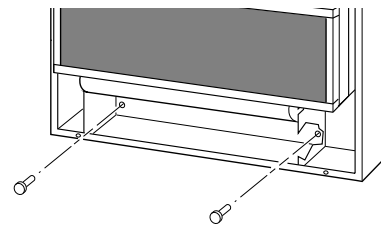

Figure 17 - Installing Bottom Mounting Screws

B. MOUNTING HEATER ON OPTIONAL HEARTH BASE

Tools needed

- #2 Phillips screwdriver
- Slotted screwdriver
- Electric drill (if securing base to floor)

The optional hearth base kit includes the following:

- Hearth base
- 4 wood screws
- 4 sheet metal screws
- Brass base trim
- Hearth insert
- 4 anchors
- Laminate sheet & adhesive
- 2 brass screws

Note: It is an option to secure GHB802A model hearth base to floor. You must secure the GHB802B, GHB802C, or GHB38 series model hearth base to floor. To secure hearth base to floor, follow instructions under *Securing Hearth Base to Floor*, below. If not securing hearth base to floor, proceed to *Mounting Heater to Optional Hearth Base*, page 11.

INSTALLATION

Continued

Securing Hearth Base to Floor

1. Position hearth base in desired location. Mark holes for drilling (see Figure 18). Remove hearth base.
2. For carpeted floor, make a small cut with a sharp knife at marked locations before drilling. If securing to a wood floor, drill a 3/4" deep hole using a 1/8" diameter drill bit. Do not use anchors in wood floors. If securing to a concrete floor, drill a 1 3/8" deep hole using a 1/4" diameter concrete drill bit. Completely insert anchors into each hole.
3. Mount heater to hearth base following steps under *Mounting Heater to Optional Hearth Base*, below. After mounting heater, position heater and hearth base over drilled holes. With slotted screwdriver, secure hearth base to floor with four wood screws.

Mounting Heater to Optional Hearth Base

1. Lay heater on its back on a table with the bottom of heater overhanging the edge of the table.
2. Remove 2 shipping screws in bottom of heater. Discard shipping screws.
3. Line up mounting holes on top of hearth base with holes in bottom of heater (see Figure 18).
4. Using a Phillips screwdriver, secure hearth base to heater with four sheet metal screws (see Figure 18).
5. Stand heater up on base.
6. Place hearth insert in hearth base as shown in Figure 19.
7. Assemble brass trim (see steps 1 through 7 under *Assembling and Attaching Brass Trim*, page 5).
8. Slide base trim on heater base. Attach brass trim to base with two brass screws included as shown in Figure 19.

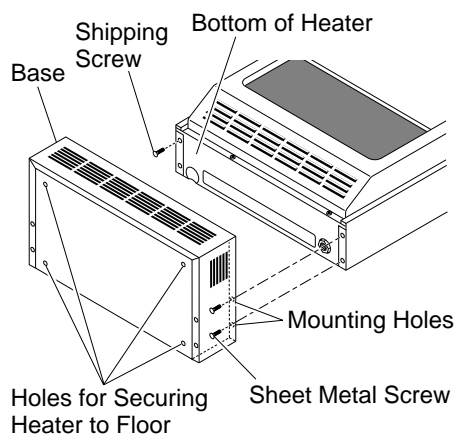

Figure 18 - Attaching Heater to Hearth Base

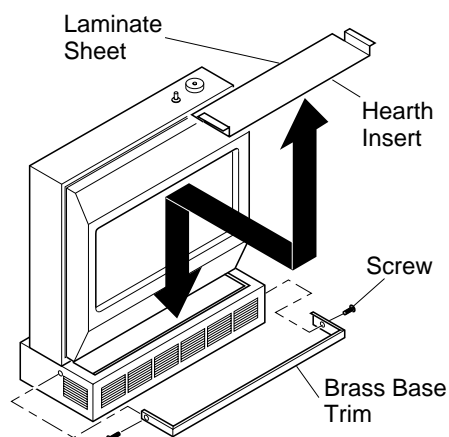

Figure 19 - Placing Hearth Insert on Heater Base and Attaching Brass Base Trim

C. MOUNTING HEATER WITH OPTIONAL HEARTH BASE (IF APPLICABLE) TO OPTIONAL MANTEL

See instructions included with mantel kit.

Assembling Mantel

IMPORTANT: Only use the optional mantels specified in this manual. See *Accessories*, page 21 for proper mantel kits. This heater is only approved for use with models GMF800 series / GMU801 series, GM900F series / GM901U series, GM700F/GM701U series, GMC22F/GMC23U/GMC24U series, GMC32F/GMC33U series, GMC34F/GMC35U series, and GMC26F/GMC27U/GMC28F series mantel kits. Using any other mantel will void the A.G.A. approval for this heater. Do not use models GMF800/GMU801 series, GM900F/GM901U series, GM700F/GM701U series, GMC22F/GMC23U/GMC24U series, GMC32F/GMC33U series, GMC26F/GMC27U/GMC28F series and GMC34F/GMC35U series mantels with any other product. If the metal base is required with your mantel, the heater must be mounted on the base first.

Comfort Glow® 15,000 TO 28,000 BTU/HR VENT-FREE NATURAL GAS HEATER

INSTALLATION

Continued

CONNECTING TO GAS SUPPLY

NOTICE: A qualified service person must connect heater to gas supply. Follow all local codes.

WARNING: Never connect heater to private (non-utility) gas wells. This gas is commonly known as wellhead gas.

IMPORTANT: Check gas line pressure before connecting heater to gas line. Gas line pressure must be no greater than 14 inches of water. If gas line pressure is higher, heater regulator damage could occur.

CAUTION : Use only new, black iron or steel pipe. Internally-tinned copper tubing may be used in certain areas. Check your local codes. Use pipe of 1/2" or greater diameter to allow proper gas volume to heater. If pipe is too small, undue loss of pressure will occur.

Installation must include a manual shutoff valve, union, and plugged 1/8" NPT tap. Locate NPT tap within reach for test gauge hook up. NPT tap must be upstream from heater (see Figure 20).

Apply pipe joint sealant lightly to male threads. This will prevent excess sealant from going into pipe. Excess sealant in pipe could result in clogged heater valves.

CAUTION: Use pipe joint sealant that is resistant to liquid petroleum (LP) gas.

Install sediment trap in supply line as shown in Figure 20, below. Locate sediment trap where it is within reach for cleaning. Locate sediment trap where trapped matter is not likely to freeze. A sediment trap traps moisture and contaminants. This keeps them from going into heater controls. If sediment

trap is not installed or is installed wrong, heater may not run properly.

IMPORTANT: Hold pressure regulator with wrench when connecting it to gas piping and/or fittings.

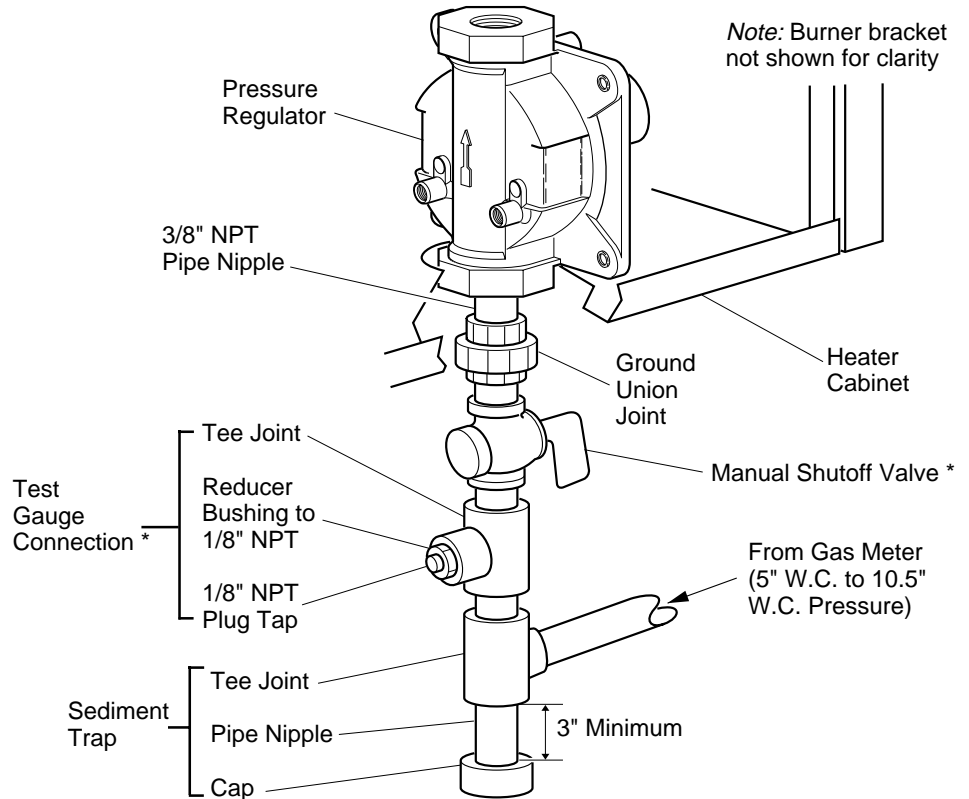

Figure 20 - Gas Connection

* An A.G.A. design-certified manual shutoff valve with 1/8" NPT tap is an acceptable alternative to test gauge connection. Purchase the optional A.G.A. design-certified manual shutoff valve from your dealer. See *Accessories*, page 21.

INSTALLATION

Continued

CHECKING GAS CONNECTIONS

⚠ WARNING: Test all gas piping and connections for leaks after installing or servicing. Correct all leaks at once.

⚠ WARNING: Never use an open flame to check for a leak. Apply a mixture of liquid soap and water to all joints. Bubbles forming show a leak. Correct all leaks at once.

Pressure Testing Gas Supply Piping System

Test Pressures In Excess Of 1/2 PSIG

1. Disconnect heater and its individual manual shutoff valve from gas supply piping system. Pressures in excess of 1/2 psig will damage heater regulator.
2. Cap off open end of gas pipe where manual shutoff valve was connected.
3. Pressurize supply piping system by either using compressed air or opening main gas valve located on or near gas meter.
4. Check all joints of gas supply piping system. Apply mixture of liquid soap and water to gas joints. Bubbles forming show a leak.
5. Correct all leaks at once.

Test Pressures Equal To or Less Than 1/2 PSIG

1. Close manual shutoff valve (see Figure 21).
2. Pressurize supply piping system by either using compressed air or opening main gas valve located on or near gas meter.
3. Check all joints from gas meter to manual shutoff valve (see Figure 22). Apply mixture of liquid soap and water to gas joints. Bubbles forming show a leak.
4. Correct all leaks at once.

Pressure Testing Heater Gas Connections

1. Open manual shutoff valve (see Figure 21).
2. Open main gas valve located on or near gas meter.
3. Make sure control knob of heater is in the OFF position.
4. Check all joints from manual shutoff valve to thermostat gas valve (see Figure 22). Apply mixture of liquid soap and water to gas joints. Bubbles forming show a leak.
5. Correct all leaks at once.
6. Light heater (see *Operating Heater*). Check all other internal joints for leaks.
7. Turn off heater (see *To Turn Off Gas to Appliance*, page 14).
8. Replace front panel.

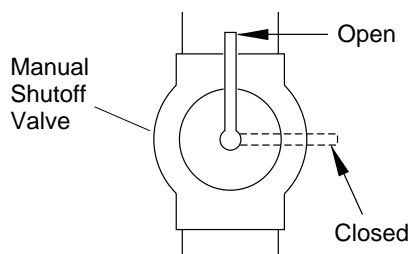

Figure 21 - Manual Shutoff Valve

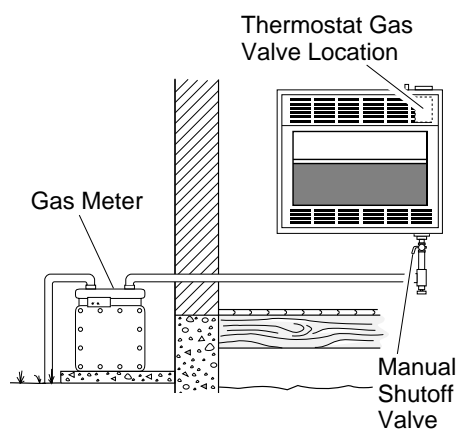

Figure 22 - Checking Gas Joints

OPERATING HEATER

**FOR YOUR SAFETY
READ BEFORE
LIGHTING**

⚠ WARNING: If you do not follow these instructions exactly, a fire or explosion may result causing property damage, personal injury or loss of life.

- A. This appliance has a pilot which must be lighted by hand. When lighting the pilot, follow these instructions exactly.
- B. **BEFORE LIGHTING** smell all around the appliance area for gas. Be sure to smell next to the floor because some gas is heavier than air and will settle on the floor.

WHAT TO DO IF YOU SMELL GAS

- Do not try to light any appliance.
 - Do not touch any electric switch; do not use any phone in your building.
 - Immediately call your gas supplier from a neighbor's phone. Follow the gas supplier's instructions.
 - If you cannot reach your gas supplier, call the fire department.
- C. Use only your hand to push in or turn the gas control knob. Never use tools. If the knob will not push in or turn by hand, don't try to repair it, call a qualified service technician or gas supplier. Force or attempted repair may result in a fire or explosion.
 - D. Do not use this appliance if any part has been under water. Immediately call a qualified service technician to inspect the appliance and to replace any part of the control system and any gas control which has been under water.

Comfort Glow® 15,000 TO 28,000 BTU/HR VENT-FREE NATURAL GAS HEATER

OPERATING HEATER

Continued

LIGHTING INSTRUCTIONS

1. STOP! Read the safety information on page 13, column 3.
2. Make sure manual shutoff valve is fully open.
3. Turn control knob clockwise to the OFF position.

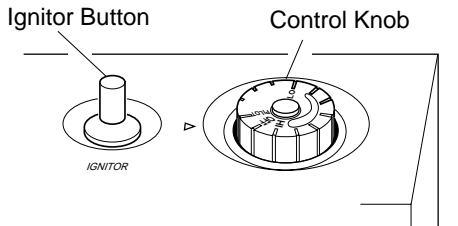

Figure 23 - Control Knob In The OFF Position

4. Wait five (5) minutes to clear out any gas. Then smell for gas, including near the floor. If you smell gas, STOP! Follow "B" in the safety information on page 13, column 3. If you don't smell gas, go to the next step.
5. Turn control knob counterclockwise to the PILOT position. Press in control knob for five (5) seconds (see Figure 23).

Note: You may be running this heater for the first time after hooking up to gas supply. If so, the control knob may need to be pressed in for 30 seconds. This will allow air to bleed from the gas system.

6. With control knob pressed in, push down and release ignitor button. This will light pilot. The pilot is attached to the front of burner. If needed, keep pressing ignitor button until pilot lights.

Note: If pilot does not stay lit, refer to *Troubleshooting*, pages 16 through 18. Also contact a qualified service person or gas supplier for repairs. Until repairs are made, light pilot with match. To light pilot with match, see *Manual Lighting Procedure*.

7. Keep control knob pressed in for 30 seconds after lighting pilot. After 30 seconds, release control knob.

- If control knob does not pop up when released, contact a qualified service person or gas supplier for repairs.

Note: If pilot goes out, repeat steps 3 through 7. This heater has a safety interlock system. Wait one (1) minute before lighting pilot again.

8. Turn control knob counterclockwise to desired heating level. The main burner should light. Set control knob to any heat level between HI and LO.

CAUTION: Do not try to adjust heating levels by using the manual shutoff valve.

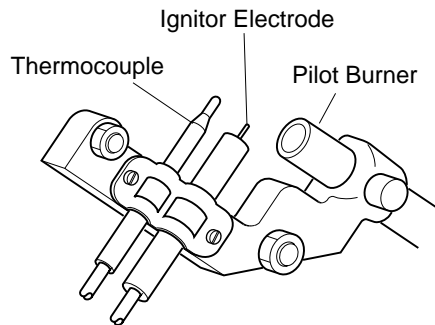

Figure 24 - Pilot

TO TURN OFF GAS TO APPLIANCE

Shutting Off Heater

1. Turn control knob clockwise to the OFF position.
2. Turn off all electric power to the appliance if service is to be performed.

Shutting Off Burner Only (pilot stays lit)

Turn control knob clockwise to the PILOT position.

THERMOSTAT CONTROL OPERATION

The thermostatic control used on this heater differs from standard thermostats. Standard thermostats simply turn on and off the burner. The thermostat used on this heater senses the room temperature. The thermostat adjusts the amount of gas flow to the burner. This increases or decreases the burner flame height. At times the room may exceed the set temperature. If so, the burner will shut off. The burner will cycle back on when room temperature drops below the set temperature.

The control knob can be set to any heat level between HI and LO.

Note: The thermostat sensing bulb measures the temperature of air near the heater cabinet. This may not always agree with room temperature (depending on housing construction, installation location, room size, open air temperatures, etc.). Frequent use of your heater will let you determine your own comfort levels.

MANUAL LIGHTING PROCEDURE

1. Remove front panel (see Figure 2, page 4).
2. Follow steps 1 through 5 under *Lighting Instructions*.
3. With control knob pressed in, strike match. Hold match to pilot until pilot lights.
4. Keep control knob pressed in for 30 seconds after lighting pilot. After 30 seconds, release control knob.
5. Replace front panel.

INSPECTING BURNER

Check pilot flame pattern and burner flame pattern often.

PILOT FLAME PATTERN

Figure 25 shows a correct pilot flame pattern. Figure 26 shows an incorrect pilot flame pattern. The incorrect pilot flame is not touching the thermocouple. This will cause the thermocouple to cool. When the thermocouple cools, the heater will shut down.

If pilot flame pattern is incorrect, as shown in Figure 26

- turn heater off (see *To Turn Off Gas to Appliance*, page 14)
- see *Troubleshooting*, pages 16 through 18

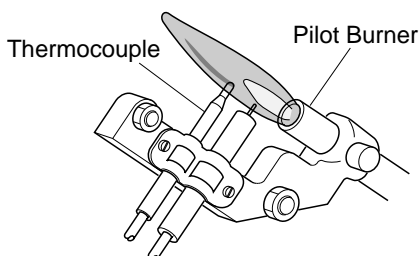

Figure 25 - Correct Pilot Flame Pattern

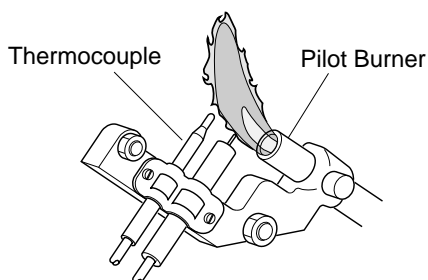

Figure 26 - Incorrect Pilot Flame Pattern

BURNER FLAME PATTERN

Figure 27 shows a correct burner flame pattern. Figure 28 shows an incorrect burner flame pattern. The incorrect burner flame pattern shows yellow tipping of the flame. It also shows the flame higher than one inch above the log.

Note: When using the heater the first time, the flame will be yellow for approximately one hour until the log cures.

WARNING: If yellow tipping occurs, your heater could produce increased levels of carbon monoxide. If burner flame pattern shows yellow tipping, follow instructions at bottom of this page.

NOTICE: Do not mistake orange flames with yellow tipping. Dirt or other fine particles enter the heater and burn causing brief patches of orange flame.

If burner flame pattern is incorrect, as shown in Figure 28

- turn heater off (see *To Turn Off Gas to Appliance*, page 14)
 - see *Troubleshooting*, pages 16 through 18
- Top of Flame About One Inch Above Logs

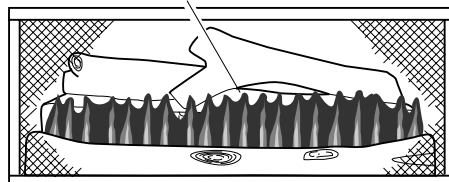

CORRECT FLAME PATTERN AT HIGH POSITION

Figure 27 - Correct Burner Flame Pattern

Yellow Tipping

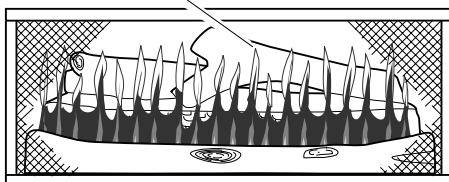

INCORRECT FLAME PATTERN AT HIGH POSITION

Figure 28 - Incorrect Burner Flame Pattern

CLEANING AND MAINTENANCE

WARNING: Turn off heater and let cool before cleaning.

CAUTION: You must keep control areas, burner, and circulating air passageways of heater clean. Inspect these areas of heater before each use. Have heater inspected yearly by a qualified service person. Heater may need more frequent cleaning due to excessive lint from carpeting, pet hair, etc.

ODS/PILOT AND BURNER

- Use a vacuum cleaner, pressurized air, or small, soft bristled brush to clean.

CABINET

Air Passageways

- Use a vacuum cleaner or pressurized air to clean.

Exterior

- Use a soft cloth dampened with a mild soap and water mixture. Wipe the cabinet to remove dust.

Comfort Glow® 15,000 TO 28,000 BTU/HR VENT-FREE NATURAL GAS HEATER

TROUBLESHOOTING

Note: All troubleshooting items are listed in order of operation.

⚠ WARNING: Turn off and unplug heater and let cool before servicing. Only a qualified service person should service and repair heater.

⚠ CAUTION : Never use a wire, needle, or similar object to clean ODS/pilot. This can damage ODS/pilot unit.

| OBSERVED PROBLEM | POSSIBLE CAUSE | REMEDY |
|---|--|---|
| When ignitor button is pressed, there is no spark at ODS/pilot | <ol style="list-style-type: none"> 1. Ignitor cable pinched or wet 2. Ignitor electrode not connected to ignitor cable 3. Piezo ignitor nut is loose 4. Broken ignitor cable 5. Ignitor electrode broken 6. Bad piezo ignitor 7. Ignitor electrode positioned wrong | <ol style="list-style-type: none"> 1. Free ignitor cable if pinched by any metal or tubing. Keep ignitor cable dry 2. Reconnect ignitor cable 3. Tighten nut holding piezo ignitor to base panel of log set. Nut is located behind base panel. 4. Replace ignitor cable 5. Replace ignitor 6. Replace piezo ignitor 7. Replace ignitor |
| When ignitor button is pressed, there is spark at ODS/pilot but no ignition | <ol style="list-style-type: none"> 1. Gas supply turned off or manual shutoff valve closed 2. Control knob not in PILOT position 3. Control knob not pressed in while in PILOT position 4. Air in gas lines when installed 5. ODS/pilot is clogged 6. Gas regulator setting is not correct | <ol style="list-style-type: none"> 1. Turn on gas supply or open manual shutoff valve 2. Turn control knob to PILOT position 3. Press in control knob while in PILOT position 4. Continue holding down control knob. Repeat igniting operation until air is removed 5. Clean ODS/pilot (see <i>Cleaning and Maintenance</i>, page 15) or replace ODS/pilot assembly 6. Replace gas regulator |
| ODS/pilot lights but flame goes out when control knob is released | <ol style="list-style-type: none"> 1. Control knob not fully pressed in 2. Control knob not pressed in long enough 3. Safety interlock system has been triggered 4. Manual shutoff valve not fully open 5. Thermocouple connection loose at control valve 6. Pilot flame not touching thermocouple, which allows thermocouple to cool, causing pilot flame to go out. This problem could be caused by one or both of the following: <ol style="list-style-type: none"> A) Low gas pressure B) Dirty or partially clogged ODS/pilot 7. Thermocouple damaged 8. Control valve damaged | <ol style="list-style-type: none"> 1. Press in control knob fully 2. After ODS/pilot lights, keep control knob pressed in 30 seconds 3. Wait one minute for safety interlock system to reset. Repeat ignition operation 4. Fully open manual shut-off valve 5. Hand tighten until snug, then tighten 1/4 turn more 6. A) Contact local natural gas company B) Clean ODS/pilot (see <i>Cleaning and Maintenance</i>, page 15) or replace ODS/pilot assembly 7. Replace thermocouple 8. Replace control valve |

OWNER'S MANUAL

TROUBLESHOOTING

Continued

| OBSERVED PROBLEM | POSSIBLE CAUSE | REMEDY |
|---|---|---|
| Burner does not light after ODS/pilot is lit | <ol style="list-style-type: none">1. Burner orifice is clogged2. Burner orifice diameter is too small3. Inlet gas pressure is too low | <ol style="list-style-type: none">1. Clean burner (see <i>Cleaning and Maintenance</i>, page 15) or replace burner orifice2. Replace burner orifice3. Contact local natural gas company |
| Delayed ignition of burner | <ol style="list-style-type: none">1. Manifold pressure is too low2. Burner orifice is clogged | <ol style="list-style-type: none">1. Contact local natural gas company2. Clean burner (see <i>Cleaning and Maintenance</i>, page 15) or replace burner orifice |
| Burner backfiring during combustion | <ol style="list-style-type: none">1. Burner orifice is clogged or damaged2. Burner damaged3. Gas regulator defective | <ol style="list-style-type: none">1. Clean burner (see <i>Cleaning and Maintenance</i>, page 15) or replace burner orifice2. Replace burner3. Replace gas regulator |
| Yellow flame during burner combustion | <ol style="list-style-type: none">1. Not enough air2. Gas regulator defective | <ol style="list-style-type: none">1. Check burner for dirt and debris. If found, clean burner (see <i>Cleaning and Maintenance</i>, page 15)2. Replace gas regulator |
| Slight smoke or odor during initial operation | <ol style="list-style-type: none">1. Residues from manufacturing processes | <ol style="list-style-type: none">1. Problem will stop after a few hours of operation |
| Heater produces a whistling noise when burner is lit | <ol style="list-style-type: none">1. Turning control knob to HI position when burner is cold2. Air in gas line3. Air passageways on heater blocked4. Dirty or partially clogged burner orifice | <ol style="list-style-type: none">1. Turn control knob to LO position and let warm up for a minute2. Operate burner until air is removed from line. Have gas line checked by local natural gas company3. Observe minimum installation clearances (see Figure 10, page 8)4. Clean burner (see <i>Cleaning and Maintenance</i>, page 15) or replace burner orifice |
| White powder residue forming within burner box or on adjacent walls or furniture. | <ol style="list-style-type: none">1. When heated, vapors from furniture polish, wax, carpet cleaners, etc. turn into white powder residue. | <ol style="list-style-type: none">1. Turn heater off when using furniture polish, wax, carpet cleaners, or similar products. |

Continued

Comfort Glow® 15,000 TO 28,000 BTU/HR VENT-FREE NATURAL GAS HEATER

TROUBLESHOOTING

Continued

- ⚠ WARNING: If you smell gas**
- Shut off gas supply.
 - Do not try to light any appliance.
 - Do not touch any electrical switch; do not use any phone in your building.
 - Immediately call your gas supplier from a neighbor's phone. Follow the gas supplier's instructions.
 - If you cannot reach your gas supplier, call the fire department.

IMPORTANT: Operating heater where impurities in air exist may create odors. Cleaning supplies, paint, paint remover, cigarette smoke, cements and glues, new carpet or textiles, etc., create fumes. These fumes may mix with combustion air and create odors.

| OBSERVED PROBLEM | POSSIBLE CAUSE | REMEDY |
|---|---|--|
| Heater produces a clicking/ticking noise just after burner is lit or shut off | 1. Metal expanding while heating or contracting while cooling | 1. This is common with most heaters. If noise is excessive, contact qualified service person |
| Heater produces unwanted odors | 1. Heater burning vapors from paint, hair spray, glues, etc. (see <i>IMPORTANT</i> statement above) 2. Gas leak. See Warning statement at top of page | 1. Ventilate room. Stop using odor causing products while heater is running 2. Locate and correct all leaks (see <i>Checking Gas Connections</i> , page 13) |
| Heater shuts off in use (ODS operates) | 1. Not enough fresh air is available 2. Low line pressure 3. ODS/pilot is partially clogged | 1. Open window and/or door for ventilation 2. Contact local natural gas company 3. Clean ODS/pilot (see <i>Cleaning and Maintenance</i> , page 15) |
| Gas odor even when control knob is in OFF position | 1. Gas leak. See Warning statement at top of page 2. Control valve defective | 1. Locate and correct all leaks (see <i>Checking Gas Connections</i> , page 13) 2. Replace control valve |
| Gas odor during combustion | 1. Foreign matter between control valve and burner 2. Gas leak. See Warning statement at top of page | 1. Take apart gas tubing and remove foreign matter 2. Locate and correct all leaks (see <i>Checking Gas Connections</i> , page 13) |
| Moisture/condensation noticed on windows | 1. Not enough combustion/ventilation air. | 1. Refer to <i>Air for Combustion and Ventilation</i> requirements (page 5) |

OWNER'S MANUAL

SPECIFICATIONS

| | |
|-------------------------------------|--------------------|
| BTU (Variable) | 15,000/28,000 |
| Type Gas | Natural Only |
| Ignition | Piezo |
| Pressure Regulator Setting | 3" W.C. |
| Inlet Gas Pressure (in. of water) * | |
| Maximum | 10.5" |
| Minimum | 5" |
| Dimensions, Inches (H x W x D) | |
| Heater | 23.75 x 25.9 x 8.5 |
| Carton | 26 x 27.75 x 10.25 |
| Weight (pounds) | |
| Heater | 29 |
| Shipping | 35 |

* For purposes of input adjustment

TECHNICAL SERVICE

You may have further questions about installation, operation, or troubleshooting.

If so, contact DESA International's Technical Service Department at 1-800-323-5190.

SERVICE HINTS

When gas pressure is too low

- pilot will not stay lit
- burner will have delayed ignition
- heater will not produce specified heat

When gas quality is bad

- pilot will not stay lit
- burner will produce flames and soot
- heater will backfire when lit

You may feel your gas pressure is too low or gas quality is bad. If so, contact your local natural gas supplier.

REPLACEMENT PARTS

Note: Use only original replacement parts. This will protect your warranty coverage for parts replaced under warranty.

Parts Under Warranty

Contact authorized dealers of this product. If they can't supply original replacement part(s), either contact your nearest Parts Central (see page 20) or call DESA International's Technical Service Department at 1-800-323-5190.

When calling DESA International, have ready:

- your name
- your address
- model number of your heater
- how heater was malfunctioning
- type of gas used (propane/LP or natural gas)
- purchase date

Usually, we will ask you to return the defective part to the factory.

Parts Not Under Warranty

Contact authorized dealers of this product. If they can't supply original replacement part(s), either contact your nearest Parts Central (see page 20) or call DESA International's Parts Department at 1-800-972-7879 for referral information.

When calling DESA International, have ready:

- model number of your heater
- the replacement part number

Comfort Glow® 15,000 TO 28,000 BTU/HR VENT-FREE NATURAL GAS HEATER

PARTS CENTRALS

These Parts Centrals are privately-owned businesses. They have agreed to support our customer's needs by providing original replacement parts and accessories.

Baltimore Electric

1348 Dixwell Avenue
Hamden, CT 06514
1-800-397-7553
203-248-7553
Parts Department

Portable Heater Parts

342 N. County Rd. 400 East
Valparaiso, IN 46383
All States
219-462-7441
1-800-362-6951

FBD

1349 Adams St.
Bowling Green, KY 42103
502-846-1199
1-800-654-8534

Four Flags Power Products

1115 Stateline Road
Niles, MI 49120
616-684-2697
1-800-268-4983
Parts Only

Master Parts Distributors

1184 Wilson Ave. NW
Grand Rapids, MI 49504
616-791-8270
1-800-446-1446

Washer Equipment Co.

1715 Main Street
Kansas City, MO 64108
KS, MO, AR
816-842-3911

East Coast Energy Products

707 Broadway
W. Long Branch, NJ 07764
732-870-8809
1-800-755-8809

Tarantin Tank Co.

P.O. Box 6129
Freehold, NJ 07728
908-780-9340
1-800-922-0724

Heater & Fireplace Store

1922 N. Route 9
Cape May Court, NJ 08210
609-624-0678

Dayton Hardware

P.O. Box 275
North Dayton Station
Dayton, OH 45404
All States
937-258-3721
OH 1-800-762-3426

Halco Enterprises

208 Carter Drive, Unit 21
West Chester, PA 19382
610-430-7717
1-800-368-0803

LA Porte's Parts & Service

2444 North 5th Street
Hartsville, SC 29550
803-332-0191
Parts Department

Cans Unlimited, Inc.

P.O. Box 645
Taylor, SC 29687
All States
803-879-3009
1-800-845-5301

OWNER'S MANUAL

ACCESSORIES

Purchase these heater accessories from your local dealer. If they can not supply these accessories, either contact your nearest Parts Central (see page 20) or call DESA International's Sales Department at 1-800-458-2472 for information. You can also write to the address listed on the back page of this manual.

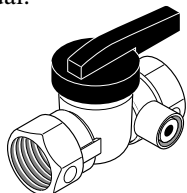

MANUAL SHUTOFF VALVE - GA5010

Manual shutoff valve with 1/8" NPT tap.

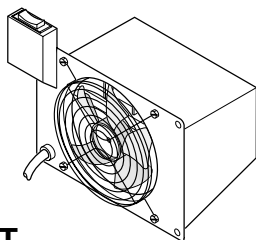

FAN KIT

GA3100A - Manually Controlled or GA3200TA - Thermostatically Controlled

Provides better heat distribution. Makes heater more efficient. Complete installation and operating instructions included.

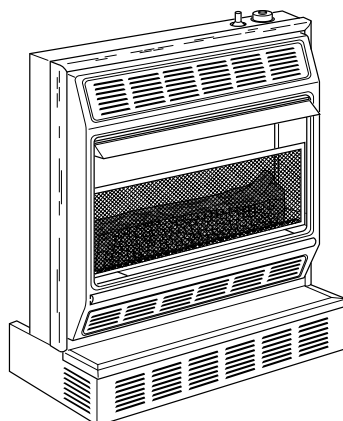

HEARTH BASE - GHB38 Series

For locating heater on the floor. Includes brass trim. Complete installation instructions included.

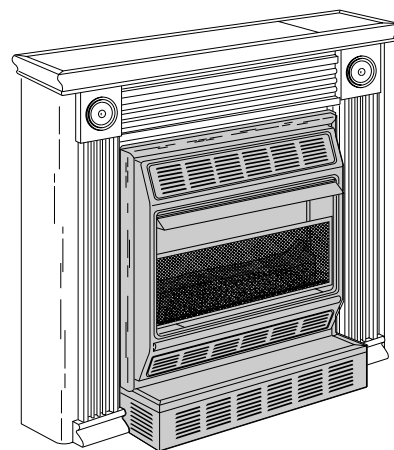

PRESTIGE MANTEL Finished - GMC22F Series

For use with heater and hearth base. Sturdy hardwood construction embellished with fluted sides and bullet medallions. Available in a walnut finish. Complete assembly and installation instructions included.

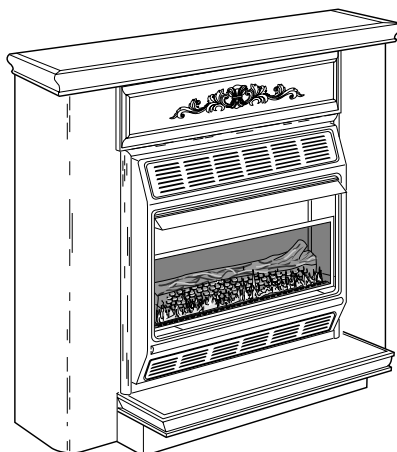

PRESTIGE MANTEL WITH BUILT-IN BASE Unfinished - GMC27U Series Finished - GMC26F Series Finished Oak - GMC28F

For use with heater. Features built-in base, sturdy hardwood construction with classic styling and attractive molding. Available in light oak finish, walnut finish, or an unfinished hardwood, ready to stain or paint. Complete assembly and installation instructions included.

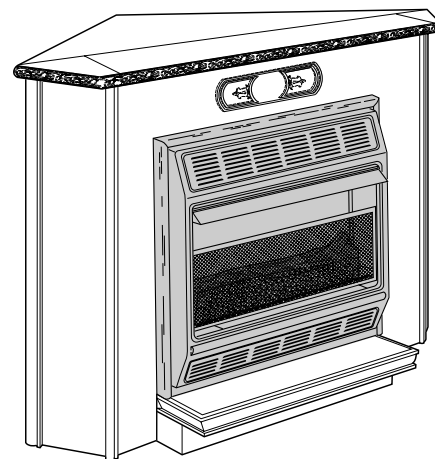

CORNER MANTEL Unfinished - GMC35U Series Finished - GMC34F Series

For use with heater. Features built-in base. Space-saving corner design featuring clean, classic lines. Available in a walnut finish or an unfinished hardwood, ready to stain or paint. Complete assembly and installation instructions included.

Comfort Glow® 15,000 TO 28,000 BTU/HR VENT-FREE NATURAL GAS HEATER

ILLUSTRATED PARTS BREAKDOWN

RFN28TD

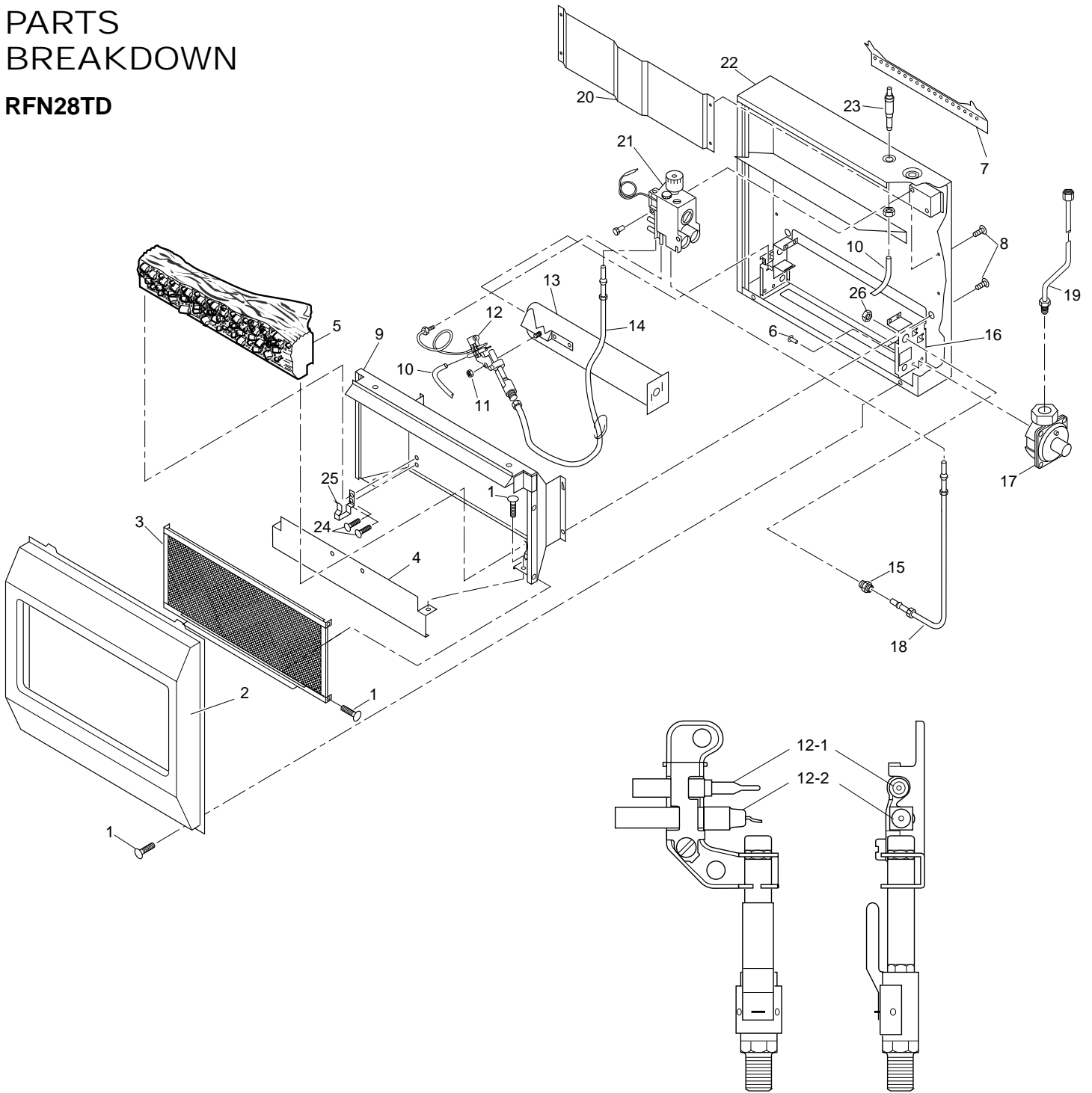

OWNER'S MANUAL

PARTS LIST

This list contains replaceable parts used in your heater. When ordering parts, follow the instructions listed under *Replacement Parts* on page 19 of this manual.

RFN28TD

| KEY NO. | PART NUMBER | DESCRIPTION | QTY. |
|------------------------------------|-------------|-----------------------------|------|
| 1 | 098304-01 | Screw, #10 x 3/8" | 6 |
| 2 | 100566-01CK | Front Panel | 1 |
| 3 | 100573-01BR | Screen Assembly | 1 |
| 4 | 100568-02BR | Burner Shield | 1 |
| 5 | 100903-04 | Log | 1 |
| 6 | M11084-38 | Screw, #8 x 3/8" | 2 |
| 7 | 099066-01 | Mounting Bracket | 1 |
| 8 | M11084-26 | Screw, #10 x 3/8" | 8 |
| 9 | 100571-03BR | Deflector Unit | 1 |
| 10 | 098271-03 | Ignitor Cable | 1 |
| 11 | 098249-01 | Nut, M5 | 2 |
| 12 | 099440-05 | ODS/Pilot Assembly | 1 |
| 12-1 | 098514-01 | Thermocouple | 1 |
| 12-2 | 098594-01 | Ignitor Electrode | 1 |
| 13 | 103447-01 | Burner | 1 |
| 14 | 098517-01 | 3/16" Pilot Tubing | 1 |
| 15 | 103845-07 | Injector | 1 |
| 16 | 103408-01 | Burner Bracket | 2 |
| 17 | 099415-07 | Pressure Regulator | 1 |
| 18 | 103255-01 | 3/8" Outlet (Burner) Tubing | 1 |
| 19 | 103256-01 | 3/8" Inlet Tubing | 1 |
| 20 | 103837-03 | Bracket Support | 1 |
| 21 | 098522-12 | Thermostat Gas Valve | 1 |
| 22 | 103502-01 | Cabinet | 1 |
| 23 | 097159-04 | Piezo Ignitor | 1 |
| 24 | 098304-03 | Screw, #8 x 3/8" | 5 |
| 25 | 101046-01 | Log Strap | 2 |
| 26 | NJF-8C | Nut, Hex | 1 |
| PARTS AVAILABLE — NOT SHOWN | | | |
| | 100562-01 | Lighting Instructions Plate | 1 |
| | 100563-01 | Warning Plate | 1 |
| | 101899-01 | Brass Trim Assembly | 1 |
| | 100642-01 | Hardware Package | 1 |
| | 100769-02 | Brass Trim Hardware | 1 |
| | 100563-01 | Warning Plate | 1 |
| | 101416-29 | Instructional Video | 1 |

WARRANTY INFORMATION

KEEP THIS WARRANTY

| |
|----------------------|
| Model _____ |
| Serial No. _____ |
| Date Purchased _____ |

Always specify model and serial numbers when communicating with the factory.

We reserve the right to amend these specifications at any time without notice. The only warranty applicable is our standard written warranty. We make no other warranty, expressed or implied.

LIMITED WARRANTY COMFORT GLOW VENT-FREE NATURAL GAS COMPACT FIREPLACE

DESA International warrants this product to be free from defects in materials and components for two (2) years from the date of first purchase, provided that the product has been properly installed, operated and maintained in accordance with all applicable instructions. To make a claim under this warranty the Bill of Sale or cancelled check must be presented.

This warranty is extended only to the original retail purchaser. This warranty covers only the cost of part(s) required to restore this heater to proper operating condition. Warranty part(s) MUST be obtained through authorized dealers of this product and/or DESA International who will provide original factory replacement parts. Failure to use original factory replacement parts voids this warranty. The heater MUST be installed by a qualified installer in accordance with all local codes and instructions furnished with the unit.

This warranty does not apply to parts that are not in original condition because of normal wear and tear, or parts that fail or become damaged as a result of misuse, accidents, lack of proper maintenance or defects caused by improper installation. Travel, diagnostic cost, labor, transportation and any and all such other costs related to repairing a defective heater will be the responsibility of the owner.

TO THE FULL EXTENT ALLOWED BY THE LAW OF THE JURISDICTION THAT GOVERNS THE SALE OF THE PRODUCT; THIS EXPRESS WARRANTY EXCLUDES ANY AND ALL OTHER EXPRESSED WARRANTIES AND LIMITS THE DURATION OF ANY AND ALL IMPLIED WARRANTIES, INCLUDING WARRANTIES OF MERCHANTABILITY AND FITNESS FOR A PARTICULAR PURPOSE TO TWO (2) YEARS FROM THE DATE OF FIRST PURCHASE; AND DESA INTERNATIONAL'S LIABILITY IS HEREBY LIMITED TO THE PURCHASE PRICE OF THE PRODUCT AND DESA INTERNATIONAL SHALL NOT BE LIABLE FOR ANY OTHER DAMAGES WHATSOEVER INCLUDING INDIRECT, INCIDENTAL OR CONSEQUENTIAL DAMAGES.

Some states do not allow a limitation on how long an implied warranty lasts or an exclusion or limitation of incidental or consequential damages, so the above limitation on implied warranties, or exclusion or limitation on damages may not apply to you.

This warranty gives you specific legal rights, and you may also have other rights that vary from state to state.

For information about this warranty write:

DESA
INTERNATIONAL
2701 Industrial Drive
P.O. Box 90004
Bowling Green, KY 42102-9004



104779 01
NOT A UPC

104779-01
REV. A
5/98