



Item# 109088

8-Gallon Air-Operated Oil Changer

User's Manual



Assembly and Operation Instructions

MADE IN CHINA

For technical questions and replacement parts, please call 1-800-556-7885.

Thank you very much for choosing a NORTHERN TOOL & EQUIPMENT CO., Product! For future reference, please complete the owner's record below:

Model: _____ Purchase Date: _____

Save the receipt, warranty and these instructions. It is important that you read the entire instruction sheet to become familiar with this product before you begin using it.

This machine is designed for certain applications only. Northern Tool & Equipment strongly recommends that this machine is not modified and/or used for any application other than that for which it was designed. If you have any questions relative to a particular application, DO NOT use the machine until you have first contacted Northern Tool & Equipment to determine if it can or should be performed on the product.

Before using this product, please read the following instructions carefully.

WARNING!

Do not extract caustic or flammable products. Do not expose the reservoir to any source of heat. While extracting high temperature oils, keep hands and face protected. Only use the device for the purpose for which it has been designed. Do not modify any component of the equipment. Only use original spare parts. Our technical office is at your full disposal for any information you may need.

ATTENTION!

Some cars have a built-in oil suction probe. In this case, connect the coupler of the oil changer B directly to the probe. For other makes of car (Volkswagen and BMW) equipped with a built-in probe having a different opening, connector(C-Volkswagen, D-BMW) must be used.

OPERATION

Fig.1: Close the suction valve (ball valve) A.

Hand tighten the drain cap B.

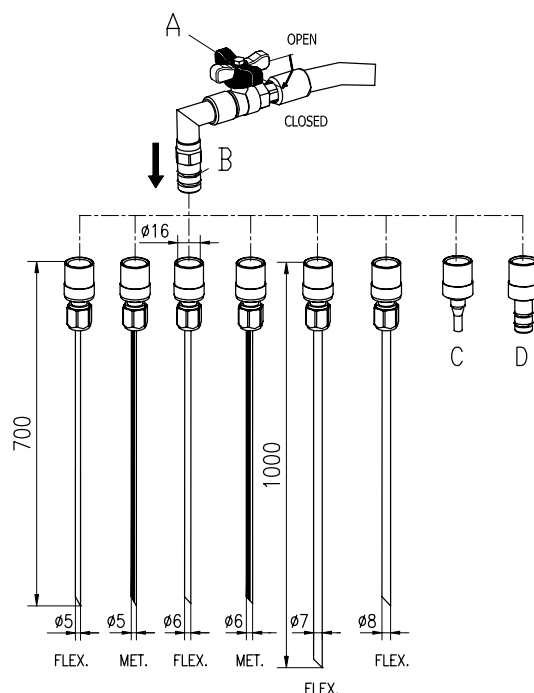
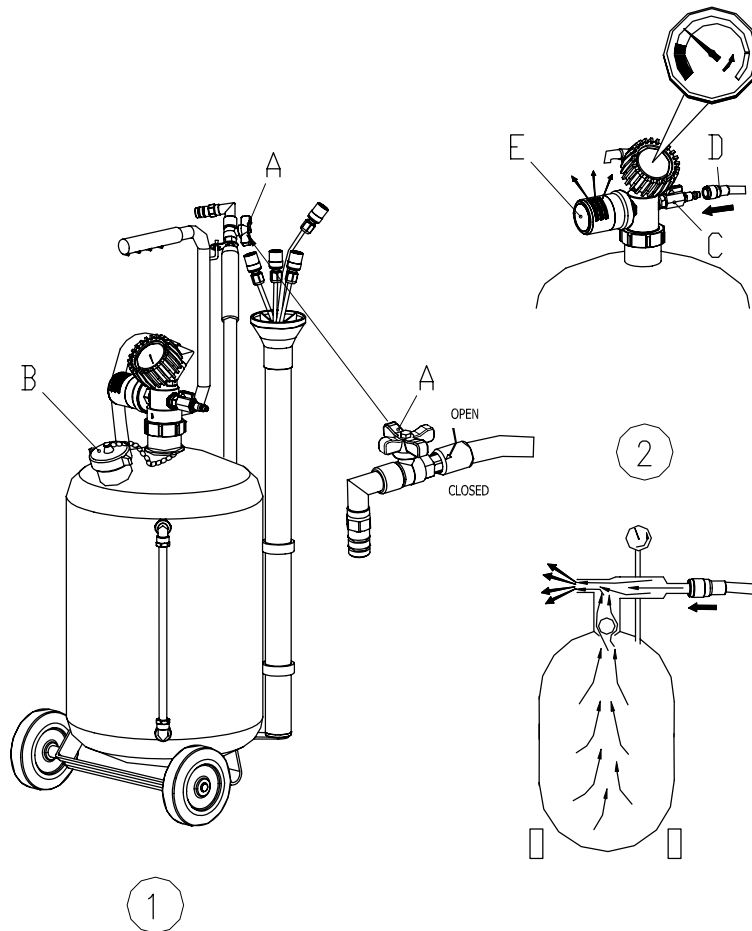

Fig.2: Connect compressed air 100PSI (7bar) to quick couple D. Open the ball

Valve C. Air will flow out from the muffler E. When the arrow of the vacuum gauge approaches the red field, after 70-80 seconds, close the ball valve C, then shut off the compressed air. The aspiration oil is now ready for use.



OIL EXTRACTION

Oils should always be removed when they are hot (158°-176°F). The suction capacity of the unit is equal to 2/3 of its reservoir capacity.

Insert the probe into the dipstick tube. Connect the probe to the unit. Open ball valve A taking care to keep the probe near the bottom of the sump.

EMPTYING THE ASPIRATION OIL

Remove the cap B and manually drain the oil.

First open suction valve A.

CAUTION!

Do not completely overturn the reservoir.

The drained fluids should not come into contact with the oil changer's venturi valve. If this happens, unscrew the muffler and blow it out with compressed air.

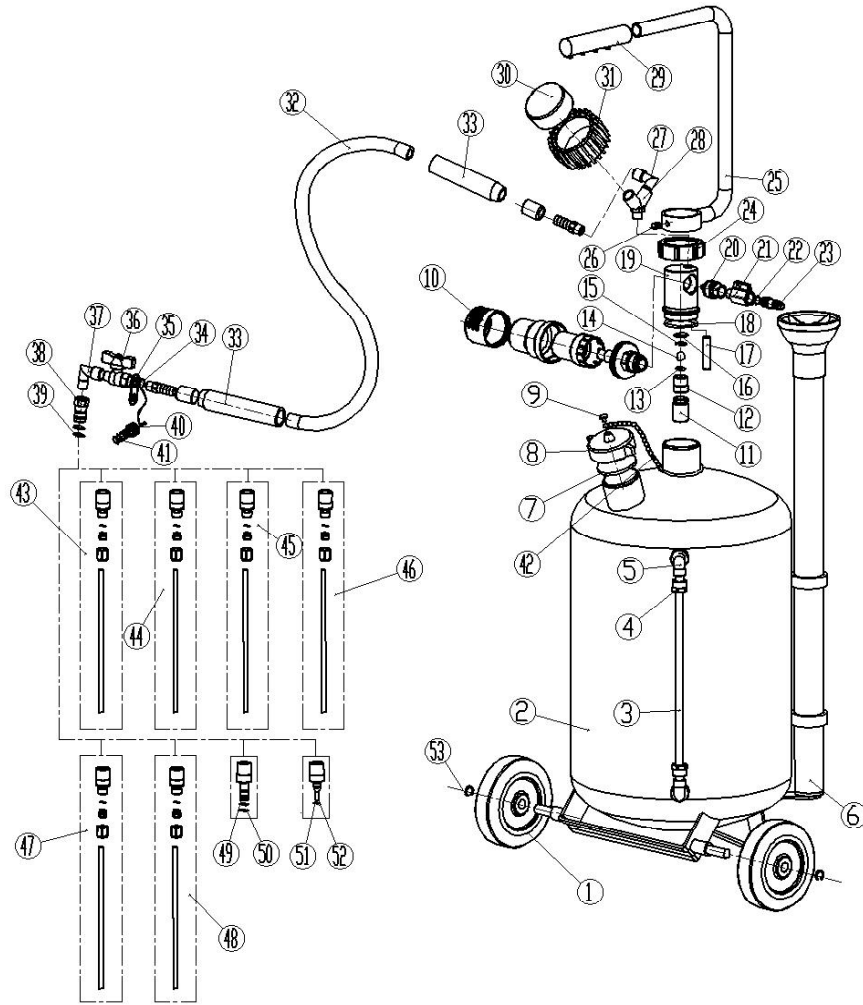

No.	Description	Quantiv	No.	Description	Quantiv	No.	Description	Quantiv
1	WHEELS	2	19	SEAT	1	37	ELBOW ADAPTER	1
2	RESERVOIR 30L	1	20	MUZZLE	1	38	LINKER	1
3	TUBE WITH LABEL	1	21	BALL VALVE	1	39	O-RING 13.8X1.8	2
4	RING	2	22	O-RING 10X1.8	1	40	STUFF	1
5	ELBOW	2	23	PLUGS	1	41	O-RING 7.5X1.8	2
6	PROBES CONTAINER	1	24	ROUND NUT WITH COLLAR	1	42	CHAIN	1
7	GASKET	1	25	GRIPE	1	43	PROBE ϕ 5X700 FLEXIBLE	1
8	PRESSURE PLUG	1	26	SCREWS	1	44	PROBE ϕ 6X700 FLEXIBLE	1
9	ROUND HEAD SCREWS	1	27	ELBOW ADAPTER	1	45	PROBE ϕ 7X700 FLEXIBLE	1
10	COMPLETE MUFFLER	1	28	Y-ELBOW ADAPTER	1	46	PROBE ϕ 8X700 FLEXIBLE	1
11	ASPIRATOR	1	29	HANDLE	1	47	PROBE ϕ 5X700 MALLEABLE	1
12	VALVE BADCY	1	30	VACUUMETER	1	48	PROBE ϕ 6X700 MALLEABLE	1
13	O-RING 9.5X2.65	1	31	PROTECT SET	1	49	CONNECTOR(VOLKSWAGEN)	1
14	STEEL BALL	1	32	COMPLETE SUCTION HOSE	1	50	O-RING 10X1.8	2
15	SPRING LOCK WASHER	1	33	PROTECT SET	2	51	CONNECTOR(BMW)	1
16	O-RING 15X2.65	1	34	CHAIN	1	52	O-RING 6.7X1.8	1
17	VITTA	1	35	HOOK	1	53	SPRING LOCK WASHER	2
18	O-RING 42.5X2.65	1	36	BALL VALVE	1			