

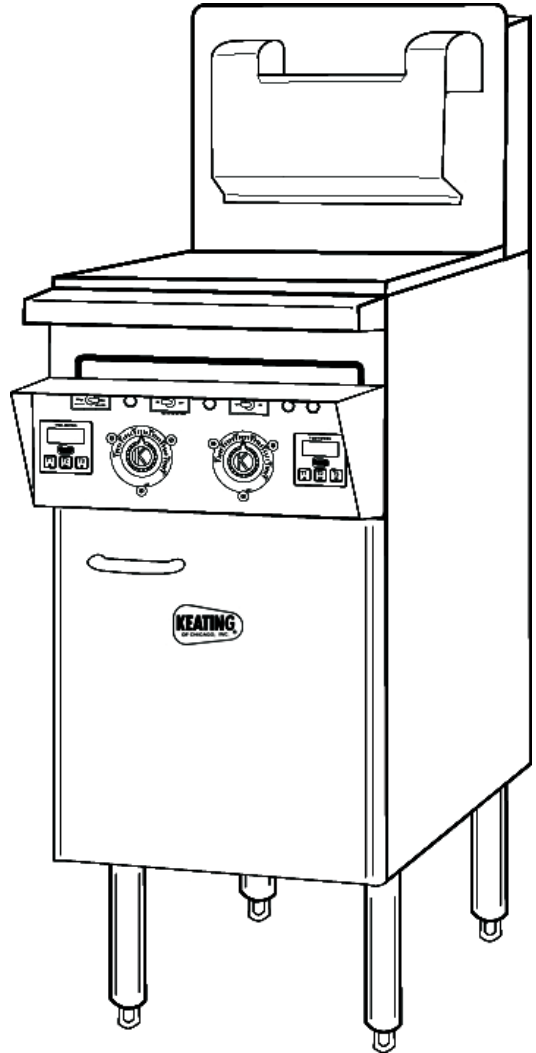

"Serving Those Who Serve The Very Best"

CUSTOM PASTA™ SYSTEM ELECTRIC SERVICE MANUAL



KEEP THIS MANUAL FOR TRAINING NEW PERSONNEL

1-800-KEATING
www.keatingofchicago.com

ⓘ NOTICE

This operating, installation, and service manual should be given to the user. The operator of the Custom Pasta™ System should be familiar with the functions and operation of the cooker. This manual must be kept in a prominent, easily reachable location near the Pasta System.

POST THIS LABEL IN A PROMINENT LOCATION ON YOUR UNIT

	<p>FOR YOUR SAFETY</p> <p>DO NOT STORE OR USE GASOLINE OR OTHER FLAMMABLE VAPORS AND LIQUIDS IN THE VICINITY OF THIS OR ANY OTHER APPLIANCE.</p>
--	--

	<p>IMPROPER INSTALLATION, ADJUSTMENT, ALTERATION, SERVICE OR MAINTENANCE CAN CAUSE PROPERTY DAMAGE, INJURY OR DEATH. READ THE INSTALLATION, OPERATING AND MAINTENANCE INSTRUCTIONS THOROUGHLY BEFORE INSTALLING OR SERVICING THIS EQUIPMENT.</p>
---	---

ⓘ NOTICE

Using any parts other than genuine, Keating of Chicago, Inc. factory manufactured part relieves the manufacturer of all warrant and liability.

ⓘ NOTICE

Keating of Chicago, Inc. manufacturer reserves the right to change specifications at any time.

TABLE OF CONTENTS

SECTION I SPECIFICATIONS 2

SECTION II INSTALLATION

Shipment and Transit	4
Installation	4
A. Positioning, Leveling, & Restraining Devices ..	5
B. Electrical Connection	5
C. Water & Drain Connection	5

SECTION III OPERATION

Filling	6
Thermostats	6
Control Panel Features	6
The Auto-Fill System	6
Cooking	6-7
Draining & Cleaning	7-8
Electronic (Digital) Timers	8-9

SECTION IV MAINTENANCE

Warranty Repairs	9
Preventive Maintenance	9
Calibration	9-10
Auto-Fill & Safety Shut Off	10
Sensor Tube Cleaning	10

SECTION V SERVICE DIAGNOSIS

Auto-Fill System	11
Cooker Heating Section	11
Troubleshooting Charts	12-13

SECTION VI PARTS LIST

Ordering Parts	14
Control Panel Assembly	14
Parts List	15

SECTION VII WIRING DIAGRAMS

14" Electric Pasta without timers	16
14" Electric Pasta with Digital timers	17
14" Electric Pasta with 138 (Black Dial) timers ..	18
14" Electric Pasta with Basket-Lift & Digital timers . . .	19
18" & 20" Electric Pasta with (Black Dial) 138 timers . .	20
18" Electric Pasta, 2-Thermostats without timers .	21
24" Electric Pasta with Digital Timers	22

WARRANTY

Keating Warranty	23
------------------------	----

I INTRODUCTION

Instructions in this manual should be read thoroughly before attempting to operate this Keating Electric Pasta Cooker. All installation and service on Keating Equipment must be performed by qualified, certified, licensed and/or authorized installation or service personnel.

Operating information for Keating equipment has been prepared for use by qualified and/or authorized personnel.

Keating equipment is made in the U.S.A. and has American sizes of hardware. All metric conversions are approximate.

GENERAL

Keating Electric Custom Pasta™ Systems are designed to give maximum production efficiency, delivering high quality food products. The following design features are incorporated in Keating Pasta Electric Systems.

STANDARD FEATURES

- Highly polished stainless steel vessel
- Highly polished stainless steel front
- Highly polished stainless steel elements
- Highly polished stainless steel thermostat bulb
- Highly polished stainless steel Hi-Limit sensor
- Grid screen over elements
- Automatic water fill with manual override
- Water solenoid and indicating light
- Starch overflow
- Two electronic timers
- Low water safety shutoff
- 1" full port front drain valve on 14; 1¼" for 18 and larger
- High temperature limit control with manual reset
- Patented accurate temperature control system ±2°F
- Ideal 35" working height
- One pair of perforated split baskets or one bulk basket
- Patented dual thermostat system
- Indicating lights for pilot and secondary thermostat on

STANDARD ACCESSORIES

- Keating Klenzer Sample
- Drain clean out rod
- Sensor Cleaning Brush

STANDARD PASTA SYSTEMS

- Sizes: 14" to 24"
- Water capacity 5½ to 24 gallons
- 24" Pasta System can cook 6 lbs. of dry pasta per load up to 110 lbs. per hour
- NSF certified
- ETL Certified listed
- ETL Sanitation Certified listed

MODEL VARIATIONS

Basket-Lift Model: Basket-Lift Model Pasta Systems come with all the same features as the standard models. The Basket-Lift mechanism lowers the baskets of food into the water when the timer button is pressed and raises the baskets when the cooking cycle is complete. Split baskets are required for these models.

SPECIFICATIONS

MODEL	CAPACITY	HEIGHT	DEPTH	WIDTH
14	7 gal.	46½"	31⅛"	15¾"
18	10 gal.	46½"	33⅛"	19¾"
20	17 gal.	46½"	35⅛"	21¾"
24	24 gal.	46½"	39⅛"	25¾"

MODEL	kW @ 240V	AMPS		SHIP WT.
		3P	1P	
14	15.5	32-56-32	65	140 lbs
18	21.4	52-52-52	89	215 lbs.
20	21.4	52-52-52	89	235 lbs.
24	28.6	79-79-52	119	285 lbs.

SAFETY PRECAUTIONS

WARNING

THIS SYMBOL WARNS YOU THAT SERIOUS BURNS OR OTHER INJURIES MAY RESULT IF SAFETY INSTRUCTIONS ARE NOT FOLLOWED.

- This service manual should be retained in a safe place for future reference. The installation of your new Pasta System must conform to local codes and with the current National Electrical Codes and regulations as applicable.
- Your ventilation hood, when installed, must conform to the current standards.
- No frame or restriction shall be constructed around the Custom Pasta System that will restrict air movement into the Pasta System or prevent proper ventilation.
- You must maintain this appliance free and clear from combustibles.
- Adequate clearance for servicing and proper operation must be maintained. Your pasta system is designed to be serviced from the front.
- Keating Custom Pasta™ Systems are not intended for household use. Installation in household voids warranty.
- ALWAYS instruct new employees on proper pasta system operation.
- A Custom Pasta System™ should be operated ONLY by properly trained personnel.
- ALWAYS turn pasta system off each night.
- ALWAYS turn pasta system off at customer power panel before servicing.
- NEVER leave a pasta system unattended during operation.
- NEVER move a pasta system when full of hot water.
- NEVER introduce objects or liquids into pasta system, while operational, which are not designed or made for cooking.
- THIS CUSTOM PASTA™ SYSTEM MAY NOT BE ALTERED, MODIFIED OR CHANGED IN ANY WAY.

WARNING



IF THE EQUIPMENT IS NOT INSTALLED, OPERATED AND MAINTAINED IN ACCORDANCE WITH THE ABOVE, CONCENTRATIONS OF CARBON MONOXIDE IN EXCESS OF THE ESTABLISHED LIMITS COULD BE PRESENT IN THE KITCHEN ENVIRONMENT.

ALL PERSONNEL IN THE WORK PLACE WHO MAY BE SUBJECT TO ANY EXPOSURE OF CARBON MONOXIDE MUST BE WARNED OF SUCH POSSIBLE EXPOSURE. THIS WARNING SHOULD BE CONVEYED IN A MANNER SO THAT IT IS CLEARLY UNDERSTOOD BY THE EMPLOYEE, AND THE EMPLOYEE SHOULD BE ASKED IF IN FACT HE OR SHE UNDERSTANDS THE CORRECT METHOD OF OPERATION OF THE EQUIPMENT AND THAT A RISK OF EXPOSURE EXISTS IF THE EQUIPMENT IS OPERATED IMPROPERLY.

WARNING

IF NOT INSTALLED, OPERATED AND MAINTAINED IN ACCORDANCE WITH THE MANUFACTURER'S INSTRUCTIONS, THIS PRODUCT COULD EXPOSE YOU TO SUBSTANCES IN FUEL OR IN FUEL COMBUSTION WHICH CAN CAUSE DEATH OR SERIOUS ILLNESS AND WHICH ARE KNOWN TO THE STATE OF CALIFORNIA TO CAUSE CANCER, BIRTH DEFECTS OR OTHER REPRODUCTIVE HARM.

II INSTALLATION



This Custom Pasta™ System MUST be installed, inspected, calibrated and serviced by qualified and/or certified and/or licensed service personnel – you may void your Keating warranty if installation is not completed per current local, national and Keating specifications. Contact your dealer for assistance.

DAMAGE DURING SHIPMENT

The Custom Pasta™ System has been assembled, tested and inspected at the factory. Upon arrival, the complete Pasta System should be checked for any damage that may have occurred during shipment.

IF EQUIPMENT ARRIVES DAMAGED

Keating does not assume responsibility for loss or damage incurred in transit.

IMPORTANT

This merchandise has been thoroughly inspected and carefully packed before leaving our plant. Responsibility for its safe delivery was assumed by the carrier at the time of shipment. Claims for loss or damage to the contents should, therefore, be made upon the carrier, as follows:

CONCEALED LOSS OR DAMAGE

Concealed loss or damage means loss or damage which does not become apparent until the merchandise has been unpacked. The contents may be damaged in transit due to rough handling even though the carton may not show external damage. When the damage is discovered upon unpacking, make a written request for inspection by the carrier's agent within fifteen days of the delivery date. Then file a claim with the carrier since such damage is the carrier's responsibility. By following these instructions carefully, we guarantee our full support of your claims to protect you against loss from concealed damage.

VISIBLE LOSS OR DAMAGE

Any external evidence of loss or damage must be noted on the freight bill or express receipt, and signed by the carrier's agent. Failure to adequately describe such external evidence of loss or damage may result in the carrier refusing to honor a damage claim. The form required to file such a claim will be supplied by the carrier.

DO NOT RETURN DAMAGED MERCHANDISE TO KEATING. FILE YOUR CLAIM AS ABOVE.

⚠ WARNING

IT MAY BE NECESSARY TO INSTALL A BACK FLOW OR CHECK VALVE ON THE WATER SUPPLY LINE TO THE PASTA COOKER. CHECK WITH EITHER YOUR LOCAL WATER OR HEALTH DEPARTMENT TO DETERMINE IF THIS IS NECESSARY IN YOUR SPECIFIC AREA.

DROP-IN PASTA COUNTER CUTOUT/INSTALLATION

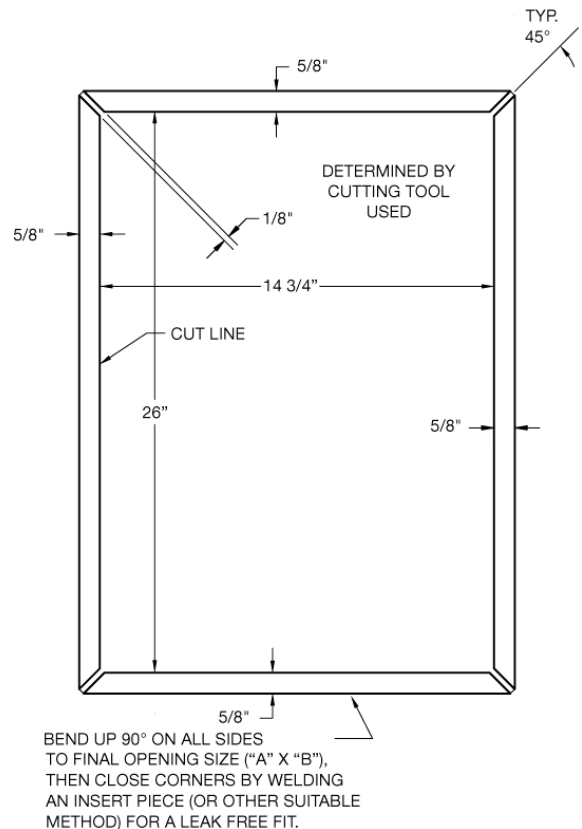

INSTALLATION NOTES

1. Minimum of 130 sq. in. unobstructed vent area near pasta cooker required for combustion.
2. All Drop-In Pasta must be 16" from any open flame.
3. Pasta must be located no more than 5" from counter top front.
4. Cabinet must be reinforced to support full weight of past in use (pasta, water, food, etc.).
5. Pasta cooker must be properly ventilated and located under an exhaust hood.

DROPPING THE PASTA COOKER INTO THE COUNTER TOP

It is only necessary to place the pasta cooker in such a position that the front edge overlaps the front raised edge of the opening.

Push the fryer forward as far as it will go holding the fryer on approximately a 15° angle, and then drop the rear of the pasta cooker into its proper position lowering it down gently so you do not deform the table or equipment stand.

POSITIONING

CLEARANCES		
	Combustible Construction	Non-Combustible Construction
Back	6"	0"
Right Side	6"	0"
Left Side	6"	0"

The pasta cooker must be no closer than 6" from any combustible material. When placed under an exhaust hood with a fire retardant system it must comply with ANSI/UL 507-(Latest Edition) and ANSI/NFPA 96-(Latest Edition). No frame or restriction can be constructed around the lower part of the pasta cooker that would restrict ventilation or air movement into the pasta cooker. You must insure adequate air supply to the pasta cooker.

Adequate clearance for servicing and proper operation must be maintained. Your pasta cooker is designed to be serviced from the front. Do not place a pasta cooker next to a deep fat fryer. Hot oil and water can cause an unstable condition creating a hazardous situation.

LEVELING

The Pasta System will operate at its highest efficiency when properly leveled. Place a level on Pasta System vessel from side to side. For Pasta Systems on legs, the bottom foot of the leg is adjustable. Turn counter clockwise to decrease height or clockwise to increase height until level. For Pasta Systems on casters, the casters are adjustable by loosening the jam nut and turning the caster in or out. When the desired level is reached, tighten the jam nut. Adjustments of more than 3/4" are not recommended on any caster. The same procedure should be followed to level the Pasta System from front to back.

Figure 2-1

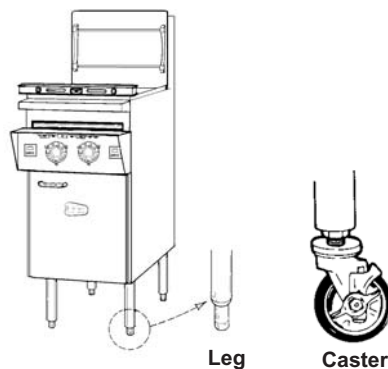

RESTRAINING DEVICES



On Custom Pasta™ System installations with casters, casters and jam nuts must be completely tightened. Adequate means must also be provided to limit the movement of the appliance without depending on the connector, the quick-disconnect device or its associated piping to limit the appliance movement.

Connectors must comply with ANSI Z21.69/CAN1 CAN/CGA 6.16 (latest edition) for connectors for movable gas appliances. Quick-disconnect devices must comply with ANSI Z21.41/CAN 1 6.9 (or latest edition) standard for quick-disconnect devices for use with gas fuel as applicable.

WARNING

IF DISCONNECTION OF THE RESTRAINT IS NECESSARY, IT MUST BE RECONNECTED WHEN THE CUSTOM PASTA™ SYSTEM IS RETURNED TO ITS ORIGINALLY INSTALLED POSITION.

ELECTRICAL CONNECTION

Your pasta cooker has been ordered in either 1 phase or 3 phase by your dealer. All electrical connections should be made by a licensed electrician. If necessary this unit can be field changed from 1 phase to 3 phase or from 3 phase to 1 phase. Have a qualified electrician refer to the wiring diagram.

WARNING

ALL ELECTRICAL WIRING LEADING TO THE PASTA COOKER MUST CONFORM TO LOCAL CODES. BE SURE THE ON/OFF SWITCH IS IN THE OFF POSITION BEFORE TURNING THE POWER ON TO THE PASTA COOKER.

WATER AND DRAIN CONNECTION

The water is to be connected to the 3/8" female pipe connection on the cabinet back, for auto-fill and the optional faucet.

Make sure this and all other connections do not leak. Check your water pressure. The auto-fill system is not designed to handle pressure greater than 60 psi. Any pressure greater than this can damage the auto-fill solenoid or cause the system to fail. If the pressure is greater than 60 psi a pressure regulator should be added. The water temperature must not exceed 150°F (65.6°C). Hot or warm water is not needed due to the instant recovery of the Custom Pasta™ System.

If during operation the boil is killed when water automatically enters the pasta cooker, turn the water pressure down until the water is added without killing the boil. The drain terminates within inches of the floor and is designed for the standard dump to drain opening.

In most cases the health department will not allow a direct connection between the cooker drain and the floor receptical. Contact your local health department for specific information in your area.

III OPERATION

FILLING

NOTE: Before filling the Pasta System make certain the vessel is sanitized, dry and the drain valve is completely closed.

Figure 3-1

Manual Water Fill Level

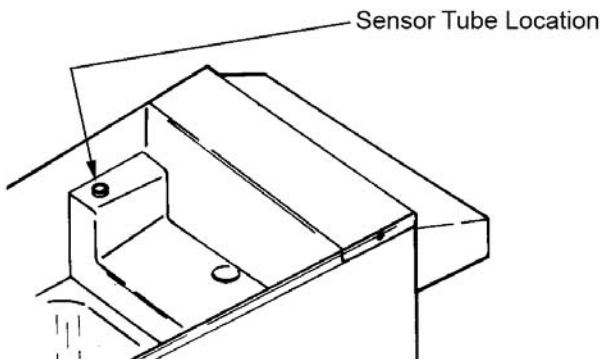

When the water fill toggle switch (located between the green and blue indicating lights) is turned on, the Pasta System vessel automatically will be filled to the proper level. If the vessel is being manually filled with water from a faucet or through the manual fill button, fill to just below the overflow deck. The black manual fill button is located to the right of the blue water fill indicating light.

THERMOSTATS

The Keating pasta cooker has two thermostats. This is to allow maximum control of the boil. The system is designed so that both thermostats will function together when called for but one thermostat will act as primary and hold the water at a rolling boil during cooking as well as idle time. The two thermostats allow the user to have complete control over the cooking process.

The right side thermostat will only activate if the left side thermostat is active. From a cold start all elements and thermostats will be on and heat the water to a rolling boil. Once the water has reached a rolling boil the right side (*secondary*) thermostat will turn off and the left side thermostat (*primary*) will hold the water at a rolling boil. When product to be cooked is dropped into the pasta cooker the drop in temperature depends on the temperature spread between the two thermostats as determined by the user.

If adding product does not turn on the secondary thermostat and the water falls below a rolling boil, increase the setting slightly on the secondary thermostat. It is not recommended that there be less than a twenty degree difference between the two

thermostats. Having less than a twenty degree difference will increase the possibility of a boil over and cause the pasta cooker to short cycle. The recommended starting temperatures for the cooker are 212°F (98.8°C) for the primary and 190°F (87.8°C) for the secondary thermostat. Using these settings with the knowledge of the operation of this system, the user can fine tune the settings to fit his specific operation.

CONTROL PANEL FEATURES

Figure 3-2

Custom Pasta System Electric Control Panel

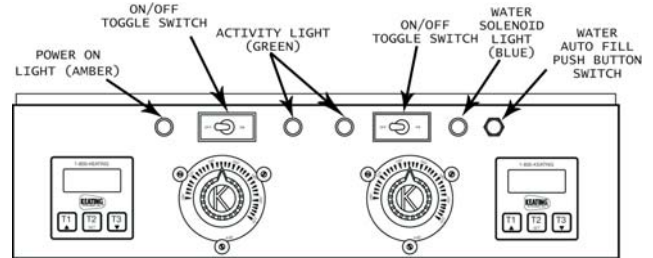

- **AMBER**—shows the power is on.
- **GREEN**—shows the secondary (right) thermostat is calling for heat from the center element(s).
- **BLUE**—shows water is filling into the Pasta System vessel through the Pasta System water solenoid valve.

NOTE: The black manual water fill button is located to the right of the blue indicating light.

THE AUTO-FILL SYSTEM

The water temperature must not exceed 120°F (48.8°C). Control of the water level is fully automatic with the auto-fill system. The water level is controlled by two circuit boards attached to the two water level sensors located on the front of the pot below the splashdeck. Once the water switch is turned to ON, the pasta cooker will start to fill with water. The heating elements will not turn on until the water level is above the bottom sensor. This is an automatic water safety built into every pasta cooker. This safety prevents the pasta cooker from accidental heat damage due to low or no water. The bottom sensor is the low water cut off. The top sensor is the water level control. Both sensors should be cleaned on a regular basis to prevent water deposits from interfering with the sensor reaction. Cleaning should be done with the brush up and down the sensor tube located on the right side of the splashdeck.

COOKING

Keating Electric Custom Pasta Systems are designed to provide maximum production efficiency and deliver high quality food products. Low-temperature cooking and highly polished stainless steel mean greater energy savings. Two thermostats are used to provide instant recovery and to save energy while water is boiling. The secondary (right)

thermostat calls for additional heat at start up or occasionally when water is added. Follow cooking procedures below for your model.

NOTE: Use of sodium chloride during the cooking process will have a detrimental effect on the cooker tank and will void the warranty.

WARNING

- **OPERATION OF THIS PASTA SYSTEM SHOULD BE LIMITED TO PERSONNEL WHO HAVE BEEN THOROUGHLY TRAINED IN OPERATING PROCEDURES.**
- **USE ONLY KEATING APPROVED BASKETS IN YOUR PASTA SYSTEM. NEVER OVERFILL BASKETS. DO NOT BANG BASKETS ON BASKET HANGERS OR PASTA SYSTEM VESSEL.**
- **CARE SHOULD BE TAKEN WHEN LOWERING BASKETS INTO PASTA SYSTEM TO PREVENT SPLASHING HOT WATER FROM PASTA SYSTEM VESSEL.**
- **NEVER LIFT BASKETS DIRECTLY OUT OF THE PASTA SYSTEM VESSEL WITHOUT DRAINING AS SEVERE INJURY MAY RESULT.**

NOTE: For counter model Pasta Systems, always check the rear drain operating handle before attempting to use the Pasta System. A safety switch prevents the Pasta System from operating if the handle is not pushed in completely and latched.

A. Standard Pasta System

1. Fill Pasta System as described on page 6 – Filling.
2. Set primary (left) thermostat to 212°F(100°C) and secondary (right) thermostat to 190°F(87.8°C).
3. When the water starts boiling, lower baskets slowly into the hot water.
4. Set timer for left or right side basket, whichever is being lowered into water.
5. When timer sounds, lift basket out of water. Place on basket hanger rods on splashback of Pasta System to allow draining of excess water.

B. Basket-Lift Model

1. Fill Pasta System as described on page 6 – Filling.
2. Set primary (left) thermostat to 212°F(100°C) and secondary (right) thermostat to 190°F(87.8°C).
3. Fill basket(s) to proper level and place on upper basket hanger rods on splashback of Pasta System.
4. Set timers to desired cooking time using T1, T2 or T3 buttons. (For Programming Timers see pages 8-9).

5. Start the timer. Basket(s) will automatically lower into the Pasta System vessel.
6. When cooking cycle is complete, an audible alarm will sound and the basket(s) will raise automatically. Allow water to drain before removing.

DRAINING

WARNING

ALWAYS SHUT THE PASTA SYSTEM OFF COMPLETELY BEFORE DRAINING. THE PASTA SYSTEM SHOULD BE DRAINED ONLY UNDER THE SUPERVISION OF PROPERLY TRAINED PERSONNEL.

1. Turn off Pasta System and open the door.

Figure 3-3

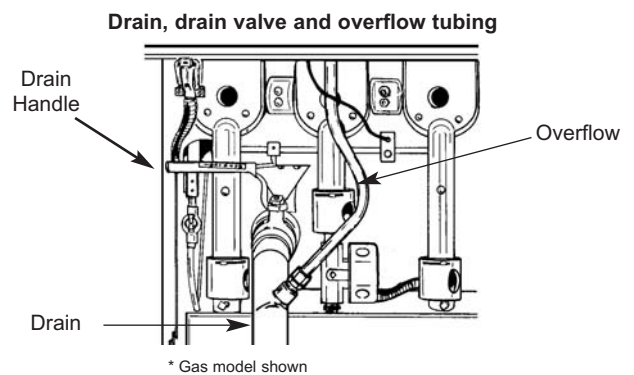

2. Slowly turn handle. The drain valve will be completely open after ¼ turn.

CLEANING

When cleaning and boiling out your Pasta System, use white vinegar and Keating Klenzer to keep your Pasta System in top condition. Once your Pasta System vessel is clean, use Keating Klenzer, the finest dry stainless steel polish available, to restore your Keating Electric Pasta System' exterior to its original luster.

CAUTION

Disconnect electric power source before cleaning.

CAUTION

To avoid damaging the Pasta System, do not power wash, spray or hose it down while cleaning.

1. Operator should be outfitted with proper attire including:
 - Water and heat resistant gloves
 - Water and heat resistant apron
 - Safety goggles
 - Water and heat resistant footwear
2. Turn the Pasta System off.
3. Drain water from Pasta System.

4. Fill Pasta System vessel with water. See page 6 – Filling.

WARNING

UNDER NO CIRCUMSTANCES SHOULD THE PASTA SYSTEM BE LEFT UNATTENDED DURING BOIL-OUT. TRAINED PERSONNEL MUST BE PRESENT DURING THE PROCEDURE TO PREVENT BOIL OVER OR TO TURN OFF THE POWER IF WATER DROPS BELOW HEAT TRANSFER TUBES.

5. Turn Pasta System on and bring water to a gentle boil.
6. Once boil has been reached, turn Pasta System off.
7. Dissolve 3 cups of vinegar for every five gallons of warm water and let soak for one hour. If there is a large build-up of scale, allow Pasta System to soak overnight.
8. While soaking, a natural fiber brush may be used to scrub the tubes and inside walls of Pasta System vessel.
9. Drain the water and vinegar.
10. Spread Keating Klenzer liberally on elements and sides of Pasta System vessel.
11. At this point, a non-abrasive scouring pad may be used to remove any leftover scale.
12. Thoroughly rinse Pasta System vessel with potable water to remove all Klenzer.
13. Prior to refilling with water, wipe the inside of the Pasta System vessel making sure all water and Klenzer has been removed.
14. Close drain valve.
15. Refill the Pasta System with fresh water. See page 6 – Filling.

HOW TO PROGRAM THE “KEATING” ELECTRONIC TIMER – PART #023709

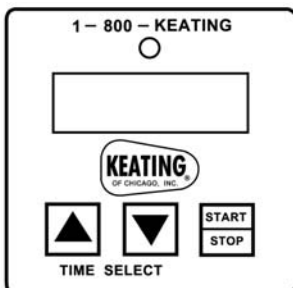

- STEP 1** Make certain power to the timer has been OFF for at least 30 seconds. Then PRESS and hold down the UP arrow button while turning the rocker power switch to the ON position.

NOTE: If power switch does not turn off timers, the

unit must be unplugged (two people may be needed).

The timer will turn ON and the display will now be indicating



The BEEPER will BEEP 4 times.

NOTE: If STEP 1 was OK, proceed to STEP 2. If not, retry Step 1 making sure the power was OFF for at least 30 seconds or more.

- STEP 2** PRESS all 3 buttons in sequence: left-center-right. The BEEPER will BEEP when each button is pressed. If BEEPER does not BEEP, the timer is defective. STOP TESTING. Reset procedure is completed when 1:00 appears on the digital display.

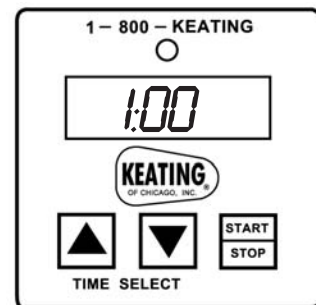

TIMER OPERATING INSTRUCTIONS

DIGITAL TIMERS

PART #056921 – REPLACES PART #023709 (FOR ALL MODELS EXCEPT 14” BASKET-LIFT)

The electronic timers provide a clearly visible and accurate display and are very easy to use. Three independent “cook” times can be set - T1, T2, and T3.

A. PROGRAMMING

To program the timers, the unit must be in the idle mode. Press and hold the set button for approximately two seconds. The display will show “Set”. Press the T1, T2, or T3 button for the cook time to be programmed. The display will show the current setting for that cook time. Use the up or down button to increment or decrement the setting. When the setting is correct, press and hold the set button again for approximately two seconds. The display will show “StO” for approximately two seconds and the timer will return to normal operation. Repeat the process as necessary for the other timers.



B. OPERATING LOGIC

When the timer is powered up, the display will show the time setting for the cook time that was operated last and the relay output contacts will be open. To start a cycle, press the desired cook time button (T1, T2, T3). The display will begin to countdown from the preset time setting and the relay output contacts will close. During the countdown the colon will flash at a one-second rate.

When the countdown has reached "00:00" the relay output contacts will open, the display will flash, and the audible alarm will sound. To cancel the audible alarm, press any button.

C. PAUSE FEATURE

To pause a cycle in progress, press any button. The relay output contacts will open, the display will flash, and the countdown will pause. To resume the countdown, press any button. The display will resume the normal countdown and the relay output contacts will close.

D. CANCELING A CYCLE

To cancel a cycle in progress press and hold any button for approximately two seconds. The relay output contacts will open and the display will show the time setting for the cook time last used.

IV MAINTENANCE

WARRANTY REPAIRS

Keating's warranty begins with the date of installation. In the event that your Pasta System, under warranty, needs repairs other than routine maintenance or cleaning, you are requested to contact Keating of Chicago Inc. at 1-800-KEATING before calling a local service company.

PREVENTIVE MAINTENANCE

Preventive maintenance should be done in daily, weekly, monthly and yearly intervals as necessary. Following preventive maintenance procedures will help keep your Pasta System working efficiently. Proper care and servicing will lead to years of quality performance.

NOTE: The most important part of any maintenance program is daily cleaning. Ninety percent of any maintenance problem is directly or indirectly related to cleanliness.

NOTE: Water level problems caused by the sensors not being cleaned adequately will not be covered under warranty.

NOTE: Use of sodium chloride during the cooking process will have a detrimental effect on the cooker vessel and will void the warranty.

PREVENTIVE MAINTENANCE CHART		
TIME FRAME	OPERATOR/OWNER	SECTION
Hourly	• Clean sensor tube with a brush	
Daily	• Check lights and controls. • Check water level. • Clean all baskets. • Clean sensor tube with a brush and vinegar	III
Weekly	• Boil-out Pasta Cooker (2-3 times/week) • Drain and clean Pasta Cooker	III
Monthly	• Verify thermostat settings (primary and secondary)	IV & V
Yearly	QUALIFIED SERVICE PERSONNEL ONLY • Check all wire connections. • Replace suspect wires.	IV & V

**High production facilities should be checked more often.*

WARNING

WHEN THE WATER LEVEL FALLS BELOW THE BOTTOM WATER SENSOR THE HEATING ELEMENTS WILL TURN OFF. IF THEY CONTINUE TO HEAT, TURN THE MAIN POWER SWITCH OFF AND CHECK AUTO-FILL SYSTEM.

LIMITED CALIBRATION

Calibration is not covered under warranty

A. Calibration

NOTE: This procedure can only be used with the primary (left side) thermostat. When calibrating the secondary (right side) thermostat you will need:

- One standard flat blade screwdriver.
- One accurate thermometer suitable for boiling water.

NOTE: For best results, water should be clean.

1. Set thermostat to 212°F(190°C).
2. Allow Pasta System to cycle three times.
3. Place an accurate thermometer in the water.

Figure 4-1: Thermometer in water



NOTE: Locate thermometer in same position for

every calibration. Position near primary thermostat (center) bulb is recommended.

- Pre-2000 model: If calibration of thermostat is found to be less than 15°F(9.44°C) off, simply loosen three dial plate retaining screws, rotate dial plate to match thermometer reading and tighten screws.

2000-model: If calibration is found to be less than 15°F (9.44°C) off, remove thermostat knob. Loosen four screws in thermostat dial plate. Replace knob. Reset dial plate to match thermometer reading. Remove knob to tighten screws on dial plate and replace knob.

If the thermostat is more than 15°F(9.44°C) off then a qualified service company must be contacted to have the Pasta System properly calibrated.

Figure 4-2

Thermostat calibration (pre-2000 model shown)

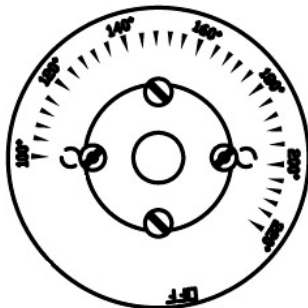
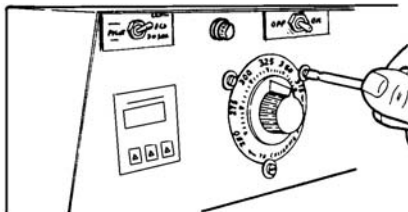

Thermostat Calibration 2000 Model

(Thermostat knob removed to reveal calibration screws.)

B. The Water Auto-Fill and Low Water Safety Shut-Off Systems

The water supply connection, located at the bottom rear of the Pasta System and marked water, is a standard 3/8" female pipe connection. The water pressure should be between 20-60 psi. If the pressure exceeds 60 psi, a pressure regulator must be used. The water temperature must not exceed 150°F(65.6°C). Hot or warm water is not needed due to the instant recovery of the Pasta System.

CAUTION

Connections suitable for hot water must be used. All connections must be tested for leaks before using the Pasta System.

NOTE: For Pasta Systems with casters, flexible hose must be used to avoid leaking when the Pasta System is moved for cleaning.

Control of the water level is fully automatic with the auto-fill system. The water level is controlled by two circuit boards and two sensors. The sensors are located in the tube on the right side of the overflow deck. The upper sensor controls the water level and the lower sensor controls the low water safety shut-off system. Once the water On/Off switch is turned on, the blue light will come on and start to fill until the water level reaches the upper sensor. The burners will not come on until the water level reaches the lower sensor, preventing the Pasta System from being damaged if there is little or no water in it. Both sensors must be cleaned with the sensor brush (like the one provided) on an hourly basis or whenever starch foams up to maintain the proper water level. Sensors must be cleaned more often in areas with hard water, in installations with softened water (due to the salt in the water) or when oil or salt is placed in the water for cooking.

The brush must be checked on a regular basis and replaced whenever it starts to wear.

CAUTION

Do not store the sensor brush in the sensor tube as it could contact the sensors, which could allow the water level to drop below the heat tubes and damage the Pasta System.

CAUTION

Using a worn brush could damage the sensors.

NOTE: Water level problems caused by the sensors not being cleaned adequately will not be covered under warranty.

WARNING

WHEN THE WATER LEVEL FALLS BELOW THE LOWER SENSOR THE BURNERS WILL SHUT OFF. IF THEY STAY ON, TURN THE MAIN POWER ON/OFF SWITCH TO THE "OFF" POSITION AND CLEAN THE SENSORS THOROUGHLY. IF THE PROBLEM STILL OCCURS, HAVE THE WATER AUTO-FILL SYSTEM CHECKED BY A QUALIFIED SERVICE TECHNICIAN.

Figure

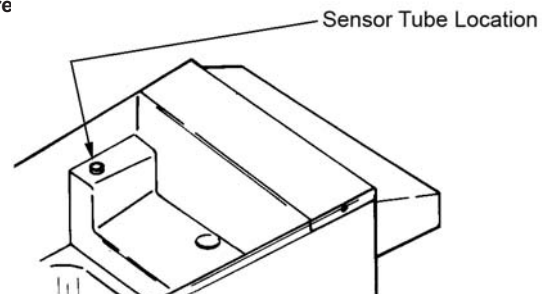

V SERVICE DIAGNOSIS

WARNING

THE COOKER MUST BE DISCONNECTED FROM ITS POWER SOURCE OR SHUT DOWN AT THE BREAKER PRIOR TO SERVICE.

AUTO-FILL SYSTEM

The auto-fill system allows the automatic addition of water to the pasta cooker during cooking or idle function. The system is controlled by the on/off switch explained in CLEANING. If the system should fail to allow the pasta cooker to fill with water, check the power supply to the pasta cooker. If the left side amber indicating light is not on, check the circuit breaker to the cooker. If the pasta cooker fails to stop adding water or fails to turn the elements off, check the water level sensors. Clean the sensors as stated in PREVENTIVE MAINTENANCE. If after cleaning, the system still fails it is possible to adjust the control boards inside the field wire box.

WARNING

THIS ADJUSTMENT IS DONE PRIOR TO SHIPMENT AT THE FACTORY. IT SHOULD ONLY BE ADJUSTED BY A QUALIFIED SERVICE TECHNICIAN.

The potentiometer is located on the control board. It is a black knob with a white triangle imprinted on it. The potentiometer adjusts the sensitivity of the probe. Adjusting this sensor will not increase the depth of the water. Improper adjustments can effect the operation of the cooker and cause damage. All boards returned to Keating are tested. The board marked with a "B" is the top water level or fill board. The board marked with an "A" is the safety or low level board. The "A" board is connected to the bottom sensor and turns the elements off when the water falls below the level of sensor. The "B" board is connected to the top sensor and adds water when the level falls below the probe. **Regular cleaning of these sensors is of the utmost importance.**

COOKER HEATING SECTION

The heating section as explained in CONTROL FEATURES is not that of a fryer. The thermostats control the heat only to one element except during heavy use. If the cooker boils over, check the thermostat setting and calibration. Remember a boil over is not covered under warranty and the pasta cooker should never be left unattended. When the ON/OFF switch on the left side is turned to the ON position, you will hear one of three contactors click in. As the thermostats turn the elements on and off, other contactors will also be heard. Refer to wiring diagram.

TROUBLESHOOTING CHART

The following diagnosis is only to be used as a guide to qualified service personnel. Keating recommends that you use a qualified service company. Call 1-800-KEATING if you need assistance in locating a qualified service company.

COMMON PROBLEMS	SOLUTIONS (FOLLOW IN SEQUENCE)
Water always filling	<ol style="list-style-type: none"> 1. Clean sensors thoroughly with brush and vinegar. 2. Adjust the sensitivity of the B Board (for the top sensor) fully clockwise. 3. If filling persists, ground out the top sensor (if filling stops, replace sensor – Part #010212). 4. If filling persists after grounding the sensor, replace the B Board (Part #001166).
Water never fills	<ol style="list-style-type: none"> 1. Turn water switch (far right) 'on.' 2. Clean sensors thoroughly with the brush and vinegar. 3. Adjust the sensitivity of the B Board (for the top sensor) fully counter clockwise (follow service instruction sheet - <i>Setting Water Level Control</i>). 4. Remove the wire from the top sensor. If filling begins, replace sensor (Part # 010212). 5. If water does not fill, place a jumper wire across terminals A & C on the B Board. If filling begins, replace B Board (Part # 001166). 6. If water does not fill, replace water solenoid (Part # 008133).
Timers counting down in the wrong mode (not minutes or seconds)	<ol style="list-style-type: none"> 1. Reset the timer (see pages 8-9).
Water leaking in the rear of the pasta cooker	<ol style="list-style-type: none"> 1. Replace fill hose (Part #037390 – sold per foot)
Breakers continue to trip	<ol style="list-style-type: none"> 1. Ensure all wires to the contactors, breakers and elements are tight. 2. Verify water is not getting on any components. 3. Check contactors for proper operation. 4. Check continuity of heating elements. 5. Replace breaker.
Heating elements won't come on	<ol style="list-style-type: none"> 1. Verify operating instructions in the manual. 2. Clean sensors with brush and vinegar. 3. Adjust sensitivity of the A Board (for the lower sensor) fully clockwise (follow service instruction sheet - <i>Setting Water Level Control</i>). 4. Place the wire attached to the lower sensor to the ground (if heating begins, replace sensor – Part #010212). 5. If heating does not begin, place a jumper wire across terminals A&C on the A Board. If heating begins, replace the A Board (Part #001167).

COMMON PROBLEMS	SOLUTIONS (FOLLOW IN SEQUENCE)
Unit is out of power	<ol style="list-style-type: none"> 1. Check electrical connection. 2. Check fuses. 3. Check Hi-Limit control.

PROBLEM	PROBABLE CAUSE	SOLUTION
Pasta Cooker has poor recovery or runs cold.	<ol style="list-style-type: none"> a. Over-filling baskets. b. Thermostat out of calibration. c. Element is faulty. d. Thermostat is faulty. e. Contactor is faulty. 	<ol style="list-style-type: none"> a. Don't overfill baskets. b. Calibrate thermostat. See pages 9-10 - Calibration. c. Replace element. d. Replace thermostat. e. Replace contactor.
Contactor chatters.	<ol style="list-style-type: none"> a. Voltage is low to Pasta Cooker. b. Contactor coil faulty. c. Connections are loose. d. Thermostat contacts do not close properly. 	<ol style="list-style-type: none"> a. Contact your electrician or the local power company and have the incoming power checked. b. Replace contactor. c. Tighten connections. d. Replace thermostat.
Basket-Lift mechanism does not operate.	<ol style="list-style-type: none"> a. Connections are loose or timer is faulty. b. Motor limit switch is faulty. c. Lift motor is faulty. d. Actuator is faulty. e. Control circuit fuse has blown. f. Relay is faulty. 	<ol style="list-style-type: none"> a. Tighten connections. Replace timer if it will not operate. b. Replace limit switch. c. Replace motor. Specify left or right side when ordering. d. Replace actuator. e. Replace fuse. f. Replace relay.
Basket-Lift motor runs, but basket doesn't move.	<ol style="list-style-type: none"> a. Cam is slipping on the motor shaft. 	<ol style="list-style-type: none"> a. Tighten cam onto motor shaft.
Basket-Lift basket goes down, but won't go up.	<ol style="list-style-type: none"> a. Basket-Lift motor limit switch is misaligned. 	<ol style="list-style-type: none"> a. Align limit switch.
Basket-Lift buzzer won't shut off.	<ol style="list-style-type: none"> a. Buzzer limit switch is misaligned. 	<ol style="list-style-type: none"> a. Align limit switch.

VI PARTS LIST

ORDERING PARTS

Parts may be ordered by part number by calling Keating at 1-800-KEATING or your local service company. You may also order online at Keating's part store, www.keatingofchicago.com.

Refer to the limited warranty in this manual for complete service and ordering information.

The model/serial plate is located on the inside of the front door. The serial and model numbers are necessary when ordering.

NOTE: On Drop-In Pasta Cookers, the model/serial plate is attached to the top of the control panel.

WARNING AND OPERATING PLATES

All warning and operating plates on the Keating Pasta Cooker should be in place at all times. If plates are damaged or lost, replace them immediately.

CUSTOM PASTA SYSTEM ELECTRIC CONTROL PANEL ASSEMBLY

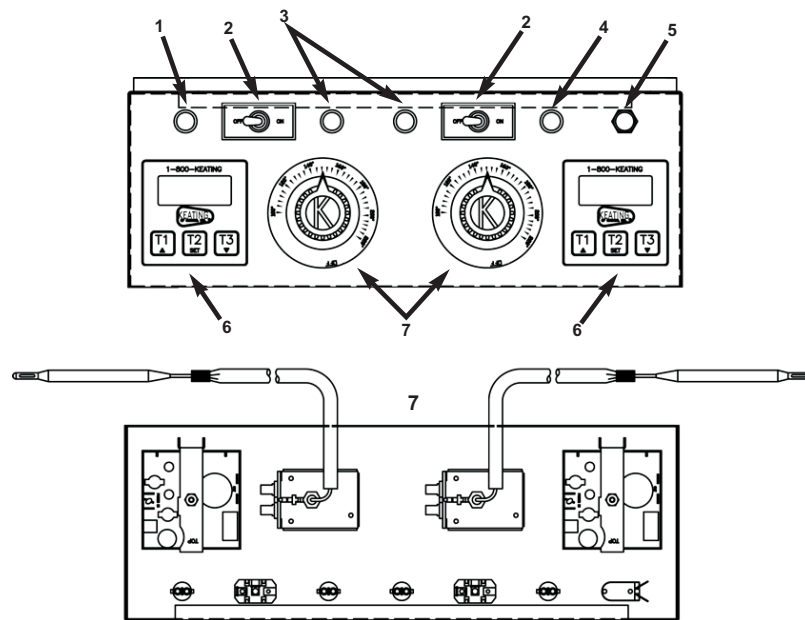
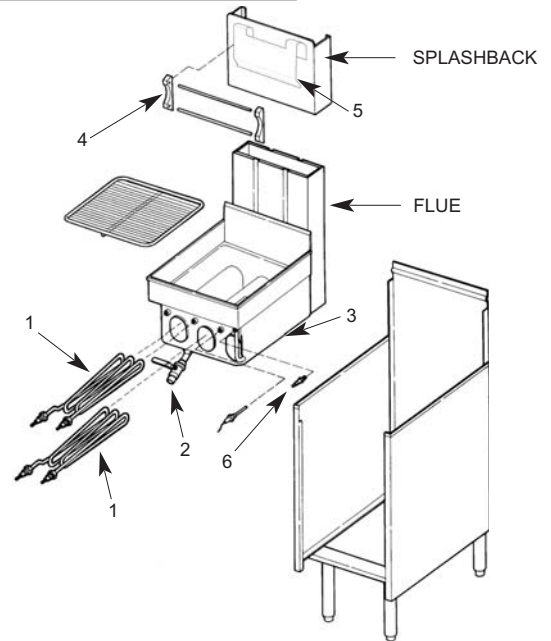
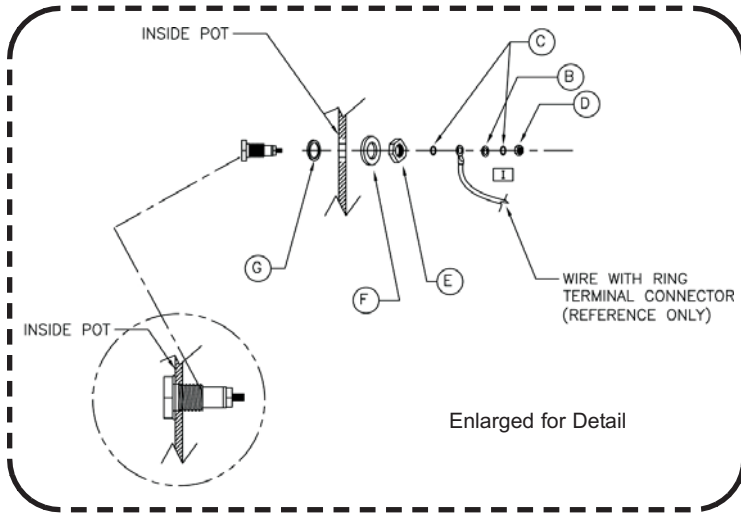

Fig 7-1

Custom Pasta System Electric Control Panel

ITEM #	DESCRIPTION	QTY	PART #
1	INDICATING LIGHT, AMBER, POWER ON	1	031624
2	TOGGLE SWITCH- MAIN ON-OFF	2	004499
3	INDICATING LIGHT, GREEN, THERMOSTAT HEATING	2	010682
4	INDICATING LIGHT, WATER FILLING	1	009256
5	MANUAL WATER FILL BUTTON	1	004304
	NUT WITH BOOT	1	009389
6	DIGITAL TIMERS	2	056921
	14" BASKET LIFT TIMER (Not Shown)	2	023709
7	THERMOSTAT	2	031466
	THERMOSTAT KNOB	2	004163
	DIAL PLATE	2	034975
	RETAINING SCREWS FOR DIAL PLATE	6	004610
Not Shown	HI-LIMIT CONTROL	1	034357
Not Shown	LOW WATER SAFETY CONTROL ("A") BOARD	1	001167
Not Shown	AUTOMATIC WATER FILL CONTROL ("B")	1	001166

PARTS LIST FOR CUSTOM PASTA SYSTEM™



ITEM	DESCRIPTION	MODELS	PART #	14	18	20	24
1	HEATING ELEMENT 220V 6500W	14" ONLY	018668	2			
1	HEATING ELEMENT 220V 6000W	18" & 20" ONLY	004353		3	3	
1	HEATING ELEMENT 220V 6000W	24" ONLY	004355				4
	(SEE DETAIL - QUANTITIES ARE PER ELEMENT)						
	B. WASHER FLAT #10		059502	2	2	2	2
	C. WASHER LOCKTOOTH #10		011562	4	4	4	4
	D. NUT 10-32 HEX		000361	2	2	2	2
	E. NUT 5/8 JAM HEX		004323	2	2	2	2
	F. WASHER 1 1/8" OD X 5/8" ID X 3/32"		004319	2	2	2	2
	G. WASHER 5/8" TEFLON		004318	2	2	2	2
2	DRAIN VALVE – 1" FRONT	14" ONLY	026813	1			
2	DRAIN VALVE HANDLE – 1" FRONT	14" ONLY	016387	1			
2	DRAIN VALVE – 1 1/4" FRONT	18", 20" & 24"	016346		1	1	1
	TERMINAL BLOCK – 600V 3P 175AMP (LARGE)		034381	1	1	1	1
	TERMINAL BLOCK 3P (SMALL)		002565				
	CIRCUIT BREAKER 40AMP 1P		012129	4	6	6	4
	FUSE 300V 3AMP		004334	2	2	2	2
	CONTACTOR 110V 3P 50AMP		011225	3	3	3	2
	CONTRACTOR 110V 4P 40AMP		005597				1
	TRANSFORMER, STEPDOWN, 220-110V 60HZ		004376	1	1	1	1
	CIRCUIT BREAKER, 50 AMP 3		033891	1	1	1	1
	DOOR CATCH, ROLLER STYLE	ALL	004540	1	1	1	1
	WATER FILL SOLENOID	ALL	008133	1	1	1	1
	HOSE CLAMP	ALL	004167	2	2	2	2
	WATER FILL HOSE	CALL 1-800-KEATING					
	BOLT 1/4-20X1/2 SHOULDER WITH FLATS	ALL	016782	2	2	2	4
4	BASKET HANGER MOUNTING BLOCK (PRE 2000 MODEL)						
		LEFT	004539	1	1	1	1
		CENTER	003813		1	1	1
		RIGHT	004538	1	1	1	1
4	BASKET HANGER ROD (PRE 2000 MODEL)		SEE BELOW	2	2	2	2
5	BASKET HANGER (2000 MODEL)		SEE BELOW	1	1	1	1
6	WATER SENSOR		010212	2	2	2	2

ITEM	DESCRIPTION	MODELS	14"	18"	20"	24"
4	BASKET HANGER ROD	2/UNIT	003895	003935	003953	003954
5	BASKET HANGER	2000 MODEL	018477	018556	018559	018562

VII WIRING DIAGRAMS

14" ELECTRIC PASTA 2-THERMOSTAT WIRING DIAGRAM (WITHOUT TIMERS)

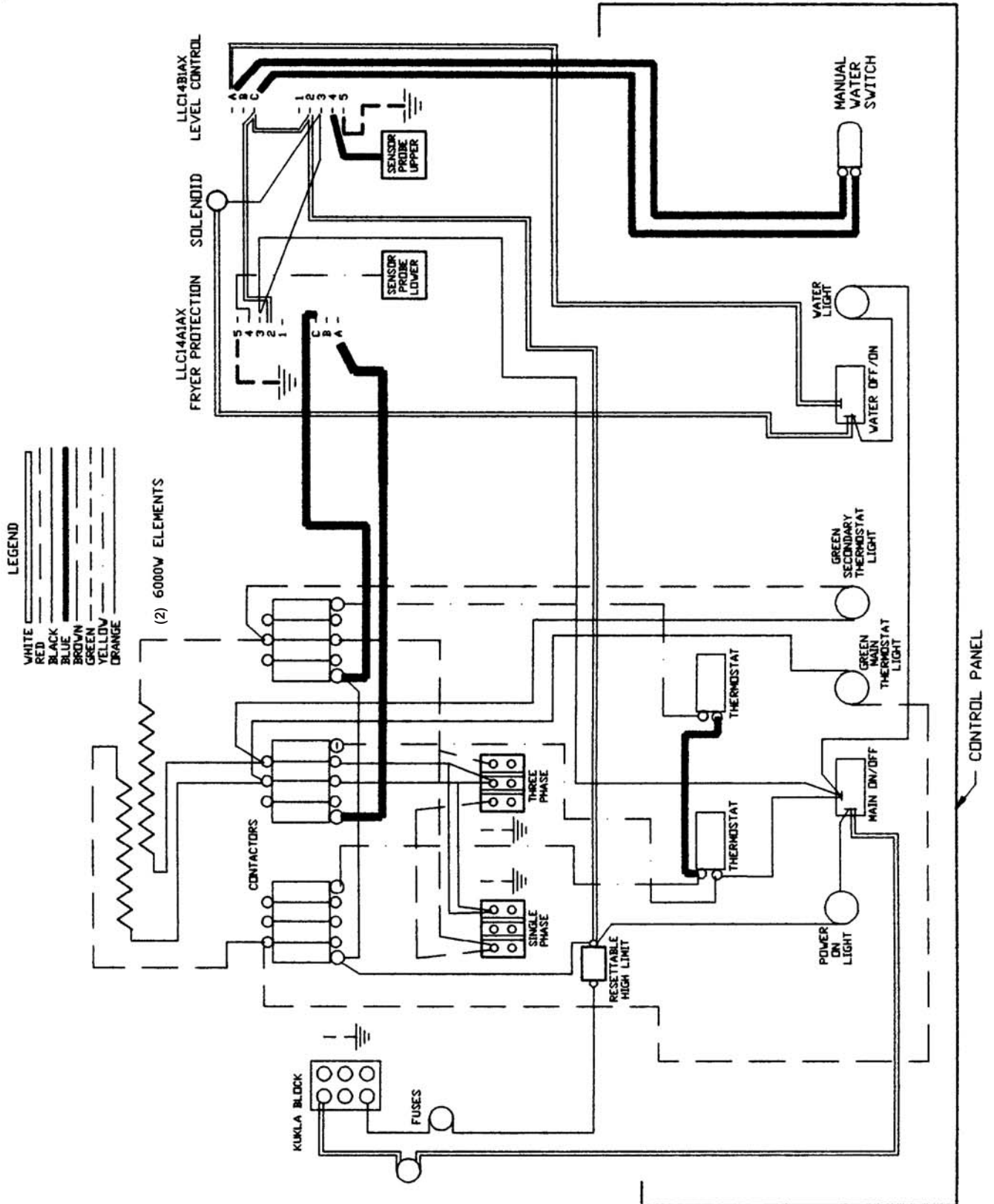

14" ELECTRIC PASTA WITH DIGITAL TIMERS WIRING DIAGRAM

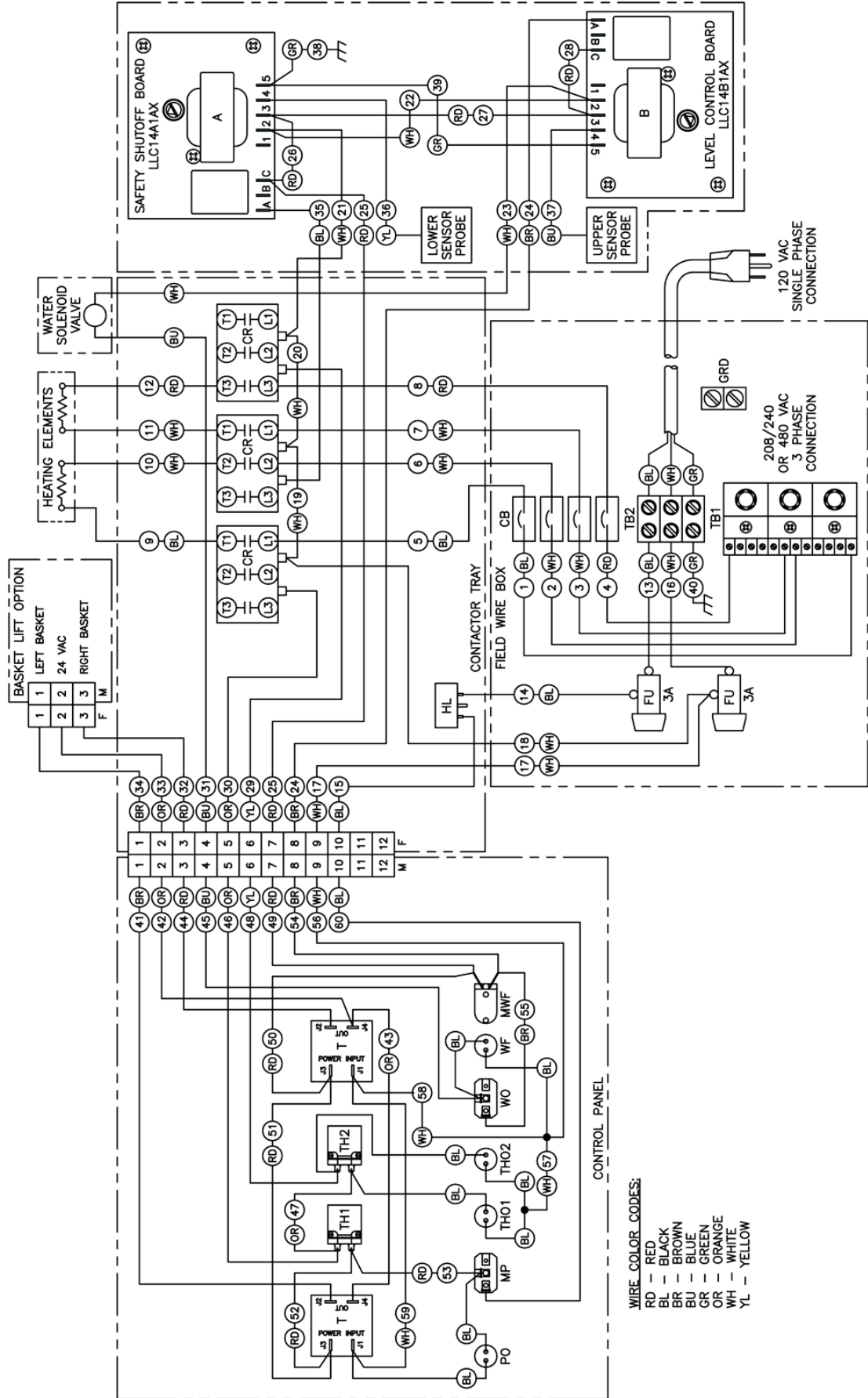

**14" ELECTRIC PASTA WITH 138 TIMERS WIRING DIAGRAM (PRE-2000 SERIES)
BLACK DIAL TIMER (NOT DIGITAL)**

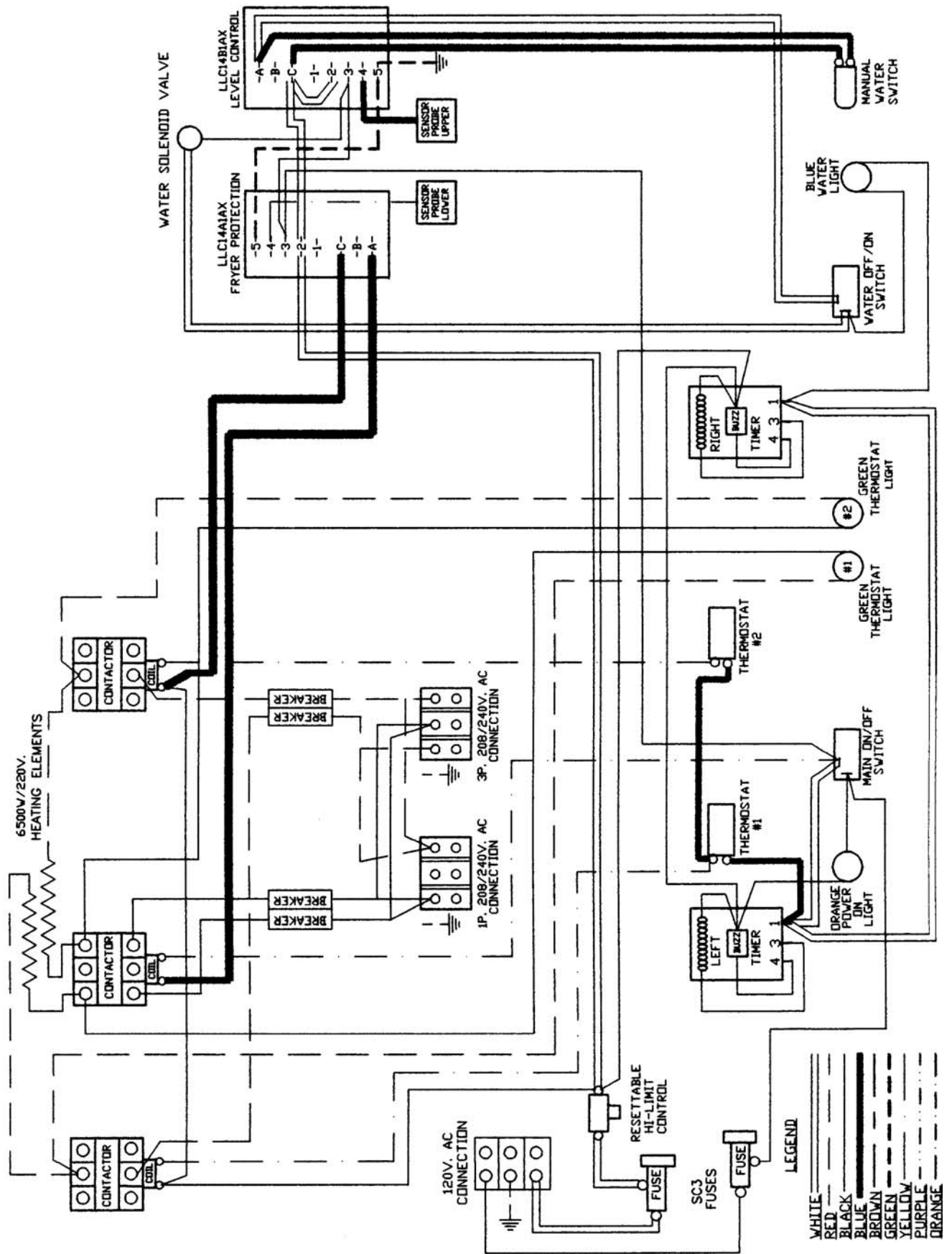

14" ELECTRIC PASTA WITH BASKET-LIFT AND DIGITAL TIMERS WIRING DIAGRAM

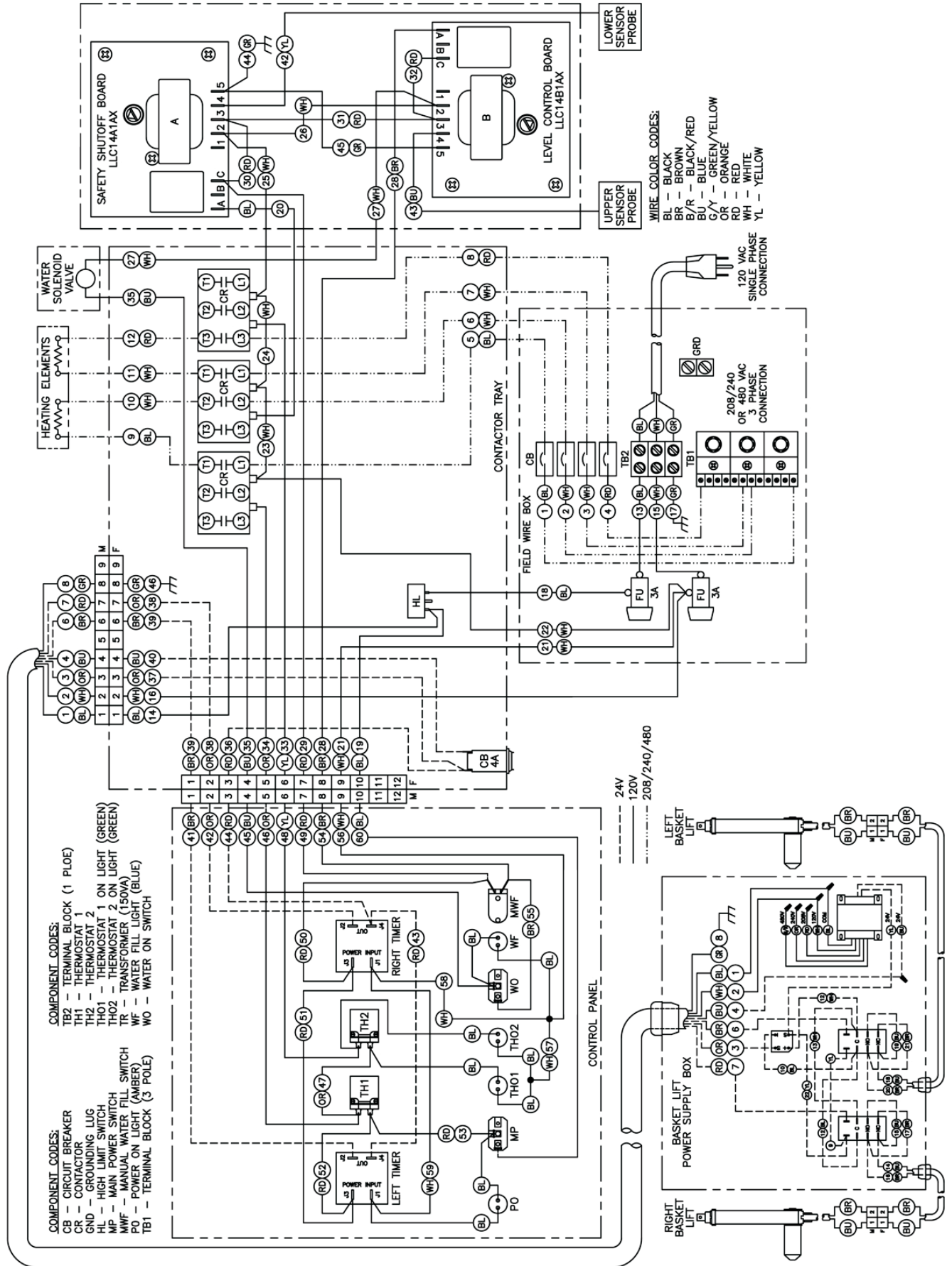

**18" & 20" ELECTRIC PASTA WITH 138 TIMERS WIRING DIAGRAM (PRE-2000 SERIES)
BLACK DIAL TIMER (NOT DIGITAL)**

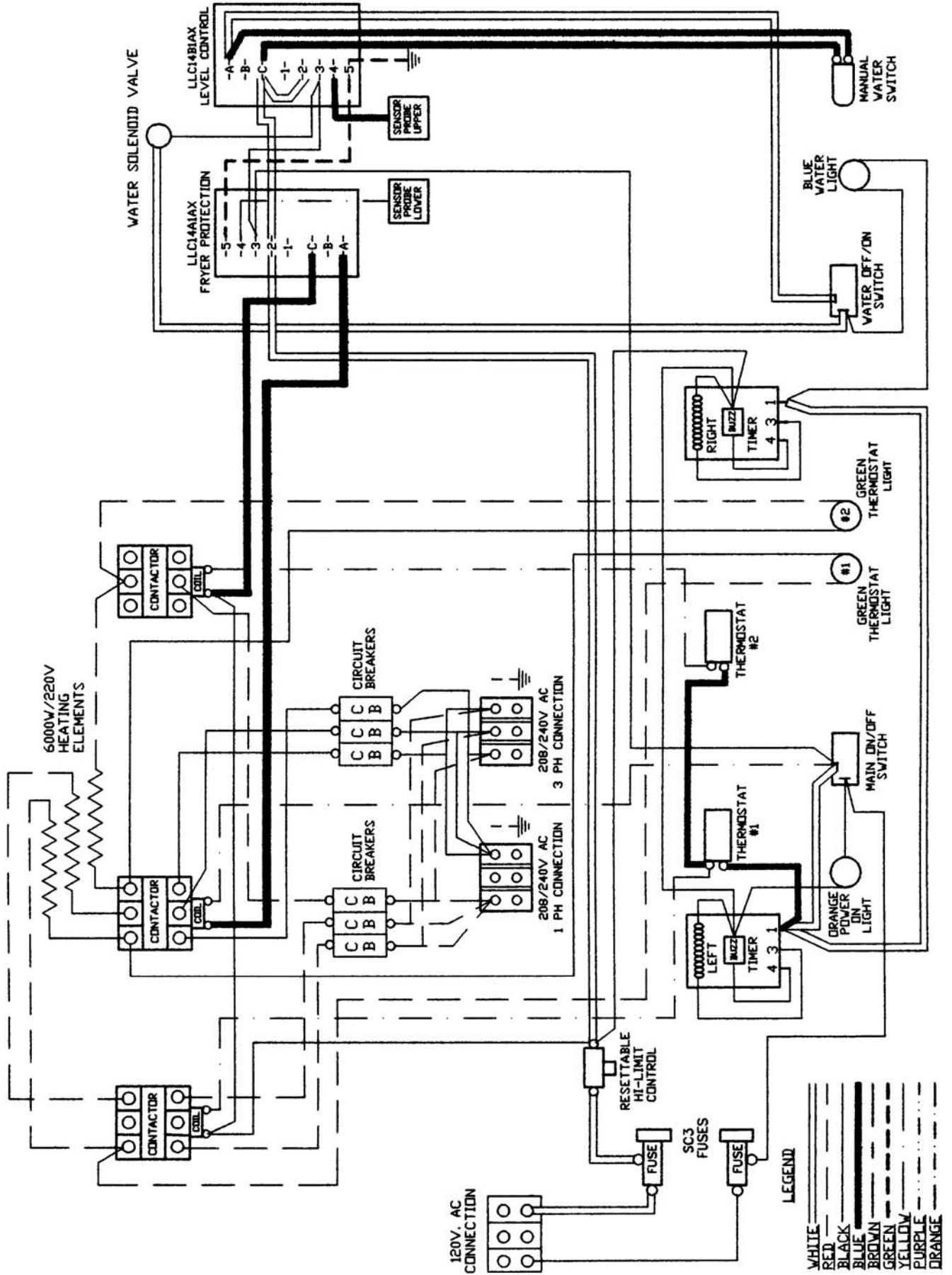

18" ELECTRIC PASTA 2-THERMOSTAT WIRING DIAGRAM (WITHOUT TIMERS)

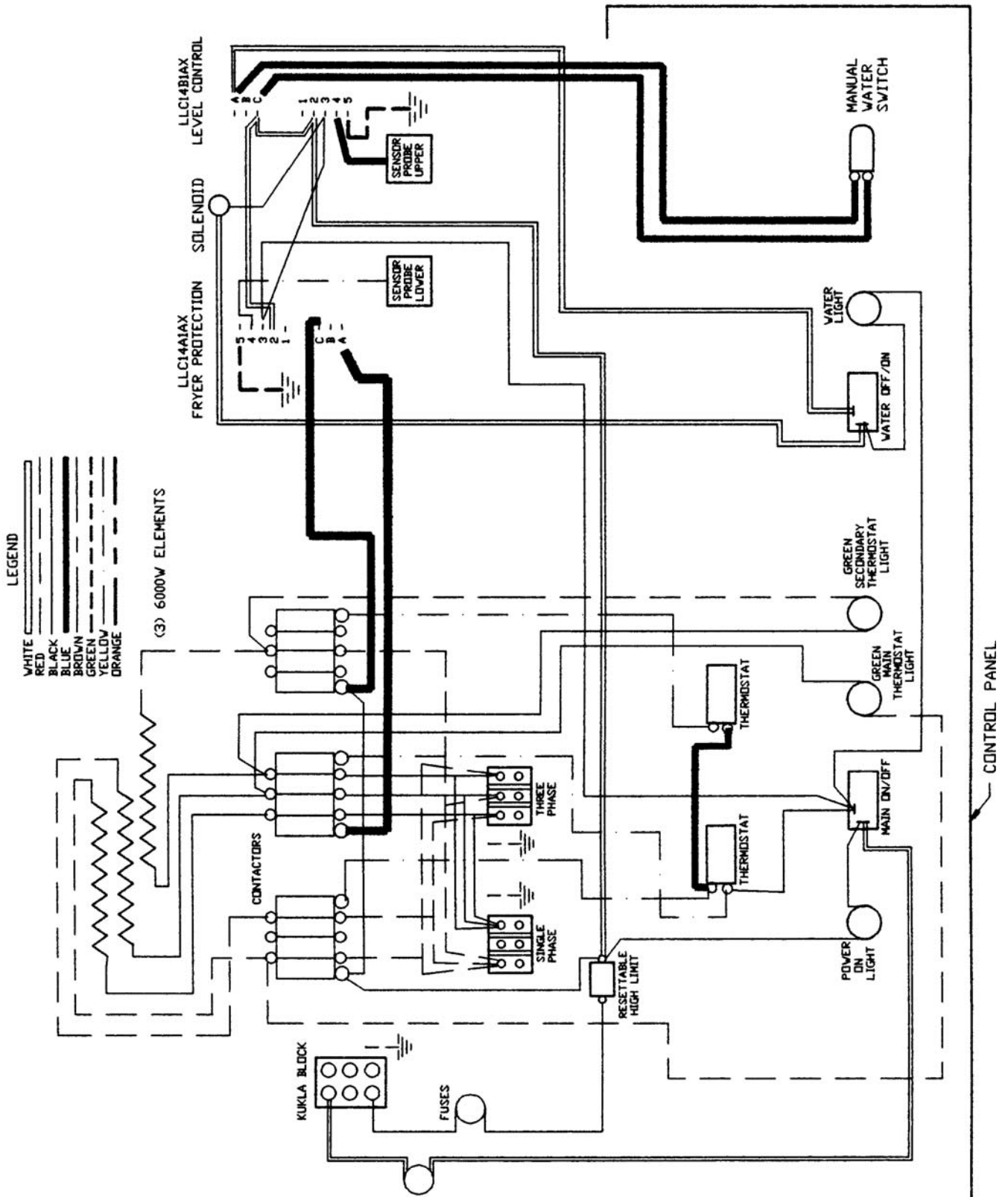

24" ELECTRIC PASTA WITH DIGITAL TIMERS WIRING DIAGRAM

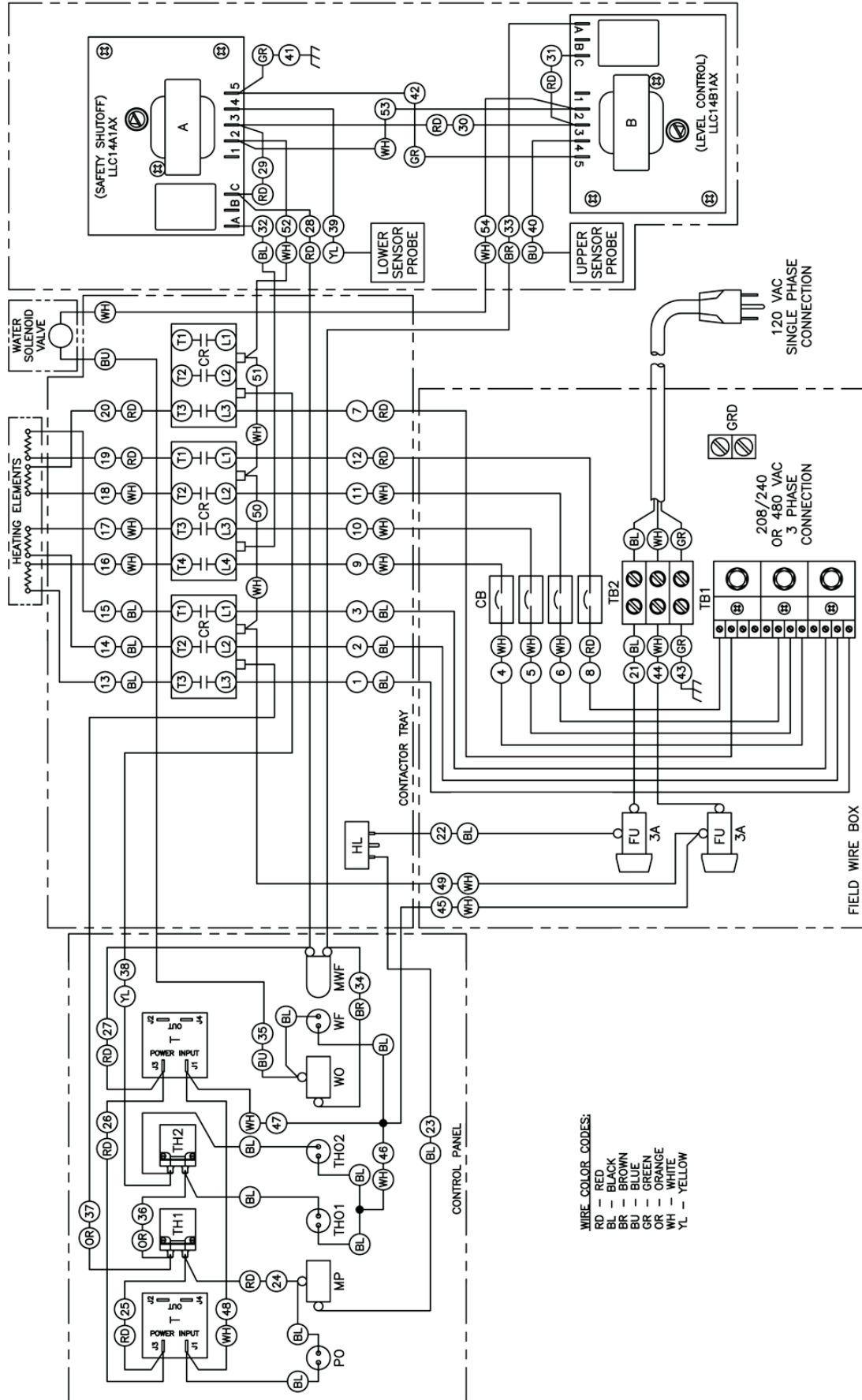



WARRANTY

LIMITED WARRANTY

Keating Of Chicago, Inc. ("Keating") warrants to the original purchaser. ("Customer"), all new Keating Fryers, Filter Systems, Griddles, Keep Krisp®. Custom Pasta Systems, Top-Side™ Cookers, Computer Timers, Fryer & Pasta Vessels, and Keating replacement parts ("products") installed after June 1, 1994 to be free to defects in material or workmanship, subject to the following terms and conditions.

LENGTH OF WARRANTY

All products other than Fryer & Pasta Vessels and replacement parts shall be warranted for a period of one year from the date of original equipment installation. Keating replacement parts are warranted for a period of ninety days from the date of installation. Fryer & Pasta Vessels are warranted as described below.

FRYER & PASTA VESSEL WARRANTY

Fryers purchased after June 1, 1994 carry a prorated vessel warranty on defects in materials or workmanship to the Customer based on the following scale:

Fryer Vessel Warranty Credit

<i>Time from Installation Date</i>	<i>100%</i>
13-60 months	80%
61-72 months	60%
73-84 months	40%
85-96 months	20%
97-108 months	10%
109-120 months	0%

The credit for the defective fryer & pasta vessel shall be applied against the cost of the replacement vessel, utilizing Keating's then current price, upon return of the vessel to Keating, (freight to be paid by Keating within the first 2 months only), only during the first 60 months, subject to the limitations described below.

LIMITATIONS OF LIABILITY

In the event of warranty claim or otherwise, the sole obligation of Keating shall be the repair and/or replacement at the option of Keating of the product or component or part thereof. Such repair or replacement shall be at the expense of Keating except that the Customer shall pay the following expenses: all freight and labor expense for Keating replacement parts; for all other products, mileage exceeding 50 miles or travel more than one hour, labor costs of more than one person, overtime rates, truck charges, difference between ground and other mode of transportation, and holiday charges. Any repair or replacement under this Limited Warranty does not constitute an extension of the original warranty for any period for the product or for any component or part thereof. Parts to be replaced under this Limited Warranty will be repaired at the option of Keating with new or functionally operative parts. Keep Krisps and Computer Timers must be returned to Keating for warranty repair or replacement. Field repairs of those items are not authorized.

THE LIABILITY OF KEATING ON ANY CLAIM OF ANY KIND, INCLUDING CLAIMS BASED ON WARRANTY, EXPRESSED OR IMPLIED, CONTRACT, NEGLIGENCE, STRICT LIABILITY OR ANY OTHER THEORIES SHALL BE SOLELY AND EXCLUSIVELY THE REPAIR OR REPLACEMENT OF THE PRODUCT AS STATED HEREIN, AND SUCH LIABILITY SHALL NOT INCLUDE, AND CUSTOMER SPECIFICALLY RENOUNCES ANY RIGHTS TO RECOVER, SPECIAL, INCIDENTAL, CONSEQUENTIAL OR OTHER INJURIES TO PERSONS OR DAMAGE TO PROPERTY, LOSS OF PROFITS OR ANTICIPATED PROFITS, OR LOSS OF USE OF THE PRODUCT. If any oral statements have been made regarding the Keating products, such statements do not constitute warranties and are not part of the contract sale. This Limited Warranty constitutes the complete, final and exclusive statement with regard to warranties.

THIS LIMITED WARRANTY IS EXCLUSIVE AND IS IN LIEU OF ALL OTHER WARRANTIES WHETHER WRITTEN, ORAL, STATUTORY OR IMPLIED, INCLUDING BUT NOT LIMITED TO ANY WARRANTY OF MERCHANTABILITY OR FITNESS FOR PARTICULAR PURPOSE OR WARRANTY AGAINST LATENT DEFECTS.

EXCLUSIONS

The warranties provided by Keating of Chicago, Inc. do not apply in the following instances:

1. Defects arising out of or resulting from improper installation or maintenance, abuse, misuse, modification or alteration by unauthorized service personnel, or any other condition not attributable to a defect in material or workmanship. Proper installation and maintenance are the responsibility of the installer and Customer, respectively. Proper installation and maintenance procedures are prescribed by the Keating Service Manual.
2. In the event that the product was damaged after leaving the factory due to flood, fire, other acts of God or accident, damage during shipment should be reported to the carrier and is not the responsibility of Keating.
3. In the event the serial number or rating plate has been removed from the product or altered.
4. On parts which would normally be worn or replaced under normal conditions, including but not limited to electric bulbs, fuses, interior and exterior finishes, gaskets and radiants.
5. With regard to adjustments and calibrations such as leveling, tightening of fasteners or plumbing connections, improper gas pressure or improper electrical supply, the checking of and changes in adjustment and calibrations are the responsibility of the installer. Proper installation procedures are prescribed by the Keating Service Manual.
6. In the event of unauthorized repairs or alterations to the Keating product.
7. With the use of sodium chloride in pasta vessels or harsh chemicals in fryer or pasta vessels.
8. Installation in Household.

The Customer must provide proof of purchase from Keating.

This Limited Warranty is valid in the 50 United States, its territories, and Canada, and is void elsewhere.

Keating products are sold for commercial use only. If any Keating product is sold as a component of another product or used as a consumer product, such Keating product is sold As Is without any warranty.

If any provision of this Limited Warranty is held to be unenforceable under the law of any jurisdiction, such provision shall be inapplicable in such jurisdiction, and the remainder of the warranty shall remain unaffected. Further in such event, the maximum exclusion or limitation allowable under applicable law shall be deemed substituted for the unenforceable provision.

This Limited Warranty shall be governed by and construed in accordance with the laws of the State of Illinois.

TO SECURE WARRANTY SERVICE

All repair services under this Limited Warranty must be authorized by Keating or performed at Keating. Authorization may be obtained by calling 1-800-KEATING within the Continental United States, Alaska, Hawaii, Puerto Rico and Canada during normal business hours (8 a.m. through 5 p.m. Central Time, Monday through Friday). When calling, please have the following information available: (1) name, address and telephone number of the Customer; (2) location of product, if different; (3) name, model number and serial number of the product; (4) installation date; and (5) description of defect. Keating will then issue a service authorization work order number to one of its approved independent servicing organizations, or request the product or part be shipped to Keating for repair or replacement, as appropriate. Any defective part subject to a claim under this Limited Warranty must be shipped freight prepaid to Keating for testing and examination. Keating's decision as to the cause and nature of any defect under this Limited Warranty shall be final.

KEATING

KEATING OF CHICAGO, INC., 1-800-KEATING, WWW.KEATINGOFCHICAGO.COM

SERVICE INFORMATION

If you have a service related question call 1-800-KEATING.

Please state the nature of the call; it will ensure speaking with the appropriate person.

Have your serial and model number available when ordering parts.

KEATING OF CHICAGO, INC.

8901 W. 50th Street, McCook, Illinois 60525-6001

Phone: (708) 246-3000 FAX: (708) 246-3100

Toll Free 1-800-KEATING (In U.S. and Canada)

www.keatingofchicago.com

***As continuous product improvement occurs, specifications may be changed without notice.**

KEATING LIMITED WARRANTY CARD

PLEASE COMPLETE AND MAIL AT ONCE--WARRANTY IS NOT IN EFFECT UNTIL CARD IS RETURNED.

WARRANTY CARD IS ALSO AVAILABLE TO COMPLETE ON LINE AT YOUR CONVENIENCE.

COMPANY: _____

ADDRESS: _____

CITY: _____ STATE: _____ ZIP: _____

DEALER: _____

DATE OF PURCHASE: _____ INVOICE NUMBER: _____

SERIAL NUMBER: _____ FRYER FILTER SYSTEM GRIDDLE

REMARKS: _____ TOP-SIDE COOKER HOT PLATE CUSTOM PASTA

I HAVE READ THE INSTALLATION AND OPERATION INSTRUCTIONS.

SIGNED: _____ DATE: _____

"Serving Those Who Serve The Very Best"®