

HP UPS R1500 Generation 2 User Guide



Part Number 419178-002
December 2009 (Second Edition)

© Copyright 2006, 2009 Hewlett-Packard Development Company, L.P.

The information contained herein is subject to change without notice. The only warranties for HP products and services are set forth in the express warranty statements accompanying such products and services. Nothing herein should be construed as constituting an additional warranty. HP shall not be liable for technical or editorial errors or omissions contained herein.

Microsoft, Windows, and Windows Server are U.S. registered trademarks of Microsoft Corporation.

Intended audience

This guide is for the person who operates, configures, maintains, and troubleshoots UPSs. HP assumes you are qualified in the servicing of high-voltage equipment and trained in recognizing hazards in products with hazardous energy levels.

Contents

Component identification	6
UPS R1500 G2 overview	6
UPS front panel	6
UPS front panel controls	7
UPS front panel LED indicators	8
UPS R1500 G2 NA/JPN/TWN rear panel	8
UPS R1500 G2 INTL rear panel	9
Installation	11
Precautions	11
Preparing to install the hardware	11
Tools required	11
Selecting a site	11
Readying the equipment	12
Installing the mounting rails	12
Installing the UPS	16
Connecting the batteries	17
Attaching the UPS front bezel	18
Selecting the UPS voltage configuration	19
Connecting the host computer	19
Connecting the serial communications port	20
Connecting the USB communications port	20
Connecting the Network Transient Protectors	20
Connecting the UPS to utility power	21
Connecting devices to the UPS	21
Powering up the UPS	22
Charging the UPS batteries	22
UPS operations	23
Modes of operation	23
Standby mode	23
Operate mode	23
Battery mode	24
Initiating a self-test	24
Silencing an audible alarm	24
Powering down the UPS	24
Power management	25
Power management software	25
Maintenance	26
Removing the UPS front bezel	26
Replacing the UPS option card	26
Replacing the batteries	27
Important battery safety information	27
Battery care and storage guidelines	27
UPS battery replacement procedure	28
Testing the new battery module	29

Replacing the UPS	29
Updating the UPS firmware	30
Configuring a USB to serial converter	30
Reassigning the USB COM ports	31
Cleaning battery spills	32
Troubleshooting	33
LED and audible alarm troubleshooting	33
UPS does not start	34
UPS operates on battery only	34
UPS frequently switches between utility and battery power	34
UPS does not provide the expected backup time	34
UPS cannot communicate with the host computer	35
UPS emits a slight clicking noise	35
Site wiring condition	35
Specifications	36
UPS physical specifications	36
UPS input specifications	36
UPS output specifications	36
Power protection specifications	37
Voltage specifications	37
Output tolerance specifications	37
Output feature specifications	37
Battery specifications	37
Battery runtime	38
Environmental specifications	38
Serial communications port pin assignment	38
Spares	40
Ordering spares	40
UPS spare parts list	40
Hardware options	40
Technical support	41
Before you contact HP	41
HP contact information	41
Warranty information	42
Limited warranty	42
\$250,000 Computer Load Protection Guarantee	42
Pre-Failure Battery Warranty	42
Recommended duration of use	43
Regulatory compliance notices	44
Regulatory compliance identification numbers	44
Federal Communications Commission notice	44
FCC rating label	44
Class A equipment	44
Class B equipment	44
Declaration of conformity for products marked with the FCC logo, United States only	45
Modifications	45
Cables	45
Canadian notice (Avis Canadien)	46
European Union regulatory notice	46

Disposal of waste equipment by users in private households in the European Union	46
Japanese notice	47
BSMI notice	48
Korean notice	48
Battery replacement notice	48
Power cord statement for Japan	49
Electrostatic discharge	50
Preventing electrostatic discharge	50
Grounding methods to prevent electrostatic discharge.....	50
Acronyms and abbreviations	51
Index	52

Component identification

UPS R1500 G2 overview

The HP UPS R1500 G2 features a 1U rack-mount design and offers power protection for loads up to 1440 VA/1000 W (NA/TWN), 1200 VA/1000 W (JPN) or 1500 VA/1000 W (INTL).

To benefit from the latest product enhancements, update to the latest versions of UPS firmware and software.

NOTE: To download the latest versions of UPS firmware and software, see the HP website (<http://www.hp.com/go/rackandpower>).

UPS front panel

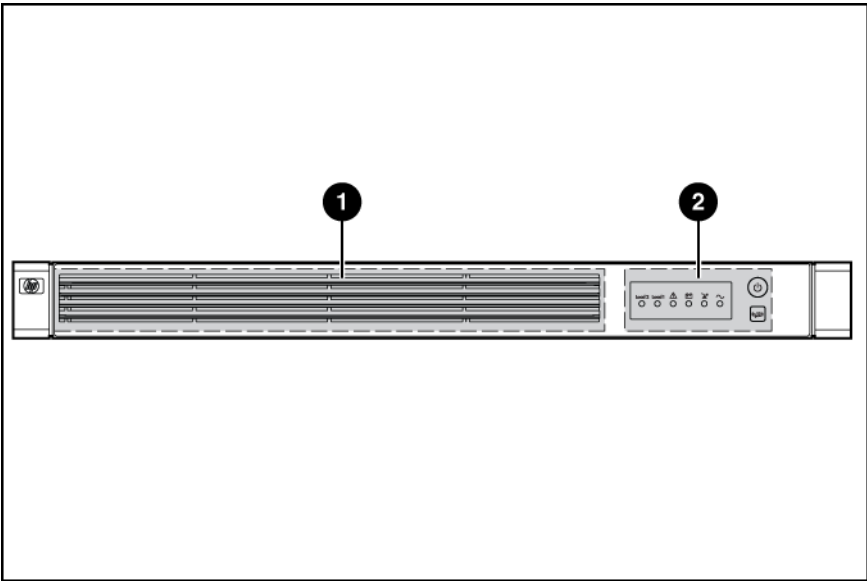

Item	Description
1	Battery compartment
2	Control buttons and LED display

UPS front panel controls

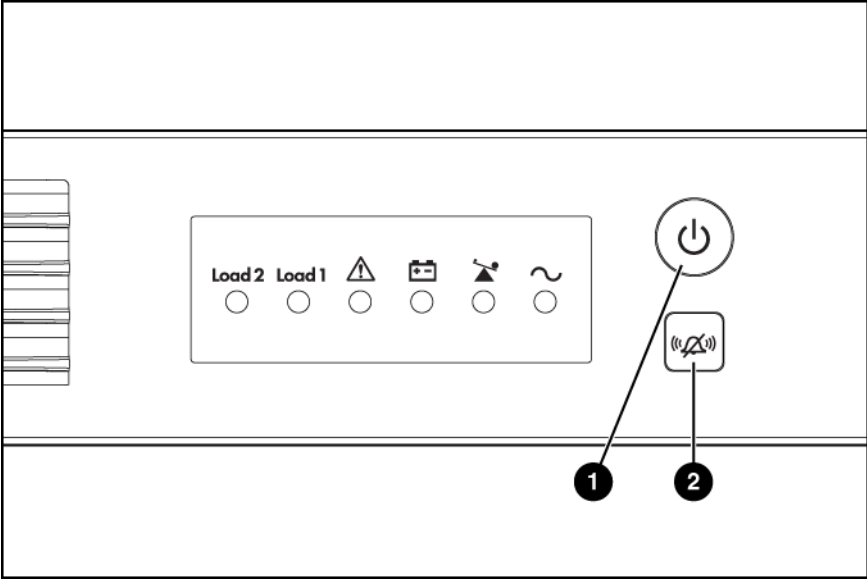

Item	Description	Function
1	Power On/Standby button	Powers up the UPS (" Powering up the UPS " on page 22).
		Powers down the UPS (" Powering down the UPS " on page 24).
		Places the UPS in Standby mode (on page 23).
2	Test/Alarm Reset button	Initiates a self-test (" Initiating a self-test " on page 24).
		Silences UPS alarms (" Silencing an audible alarm " on page 24).

UPS front panel LED indicators

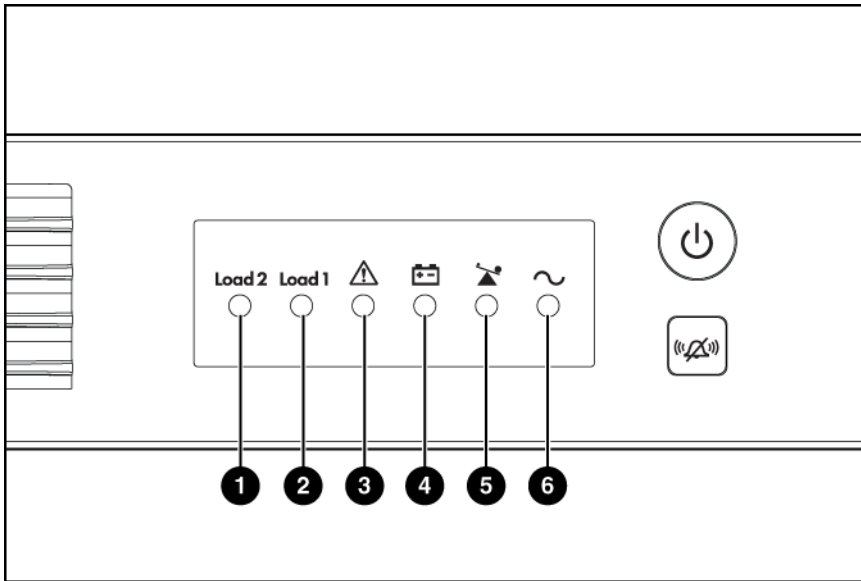

Item	LED description
1	Load Segment 2
2	Load Segment 1
3	General Alarm
4	On Battery
5	Overload
6	Power On

For more information, see "LED and audible alarm troubleshooting (on page 33)."

UPS R1500 G2 NA/JPN/TWN rear panel

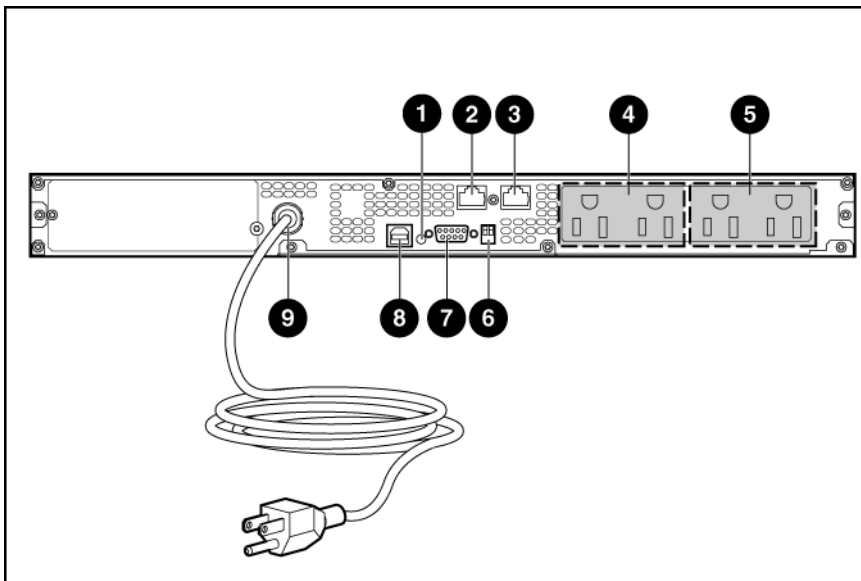

Item	Description
1	Site Wiring Fault LED
2	Network Transient Protector IN jack
3	Network Transient Protector OUT jack
4	Load segment 1 (two NEMA 5-15 output receptacles for surge and battery backup protection)
5	Load segment 2 (two NEMA 5-15 output receptacles for surge and battery backup protection)
6	Voltage configuration DIP switches
7	Serial communications port
8	USB communications port
9	Input power cord with NEMA 5-15 plug (BSMI approved for TWN)

UPS R1500 G2 INTL rear panel

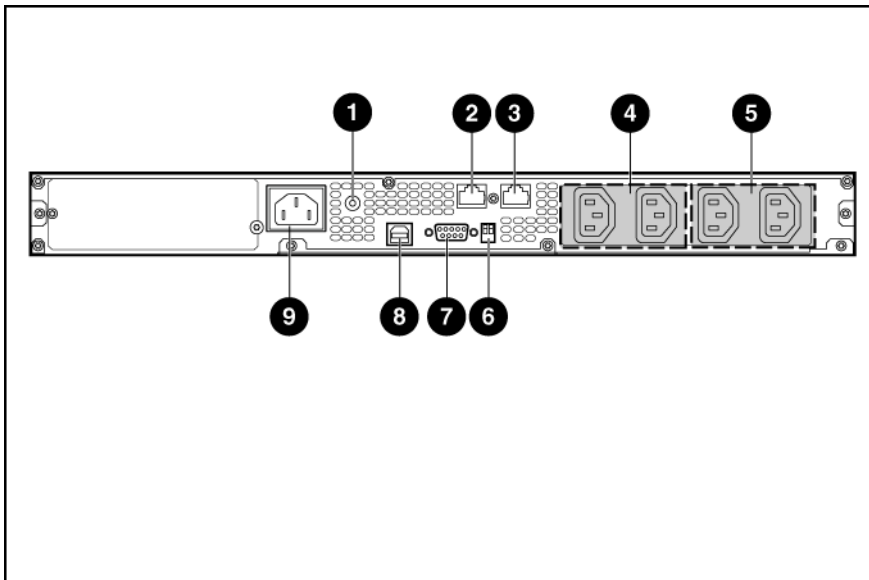

Item	Description
1	Input circuit breaker
2	Network Transient Protector IN jack
3	Network Transient Protector OUT jack
4	Load segment 1 (two IEC-320-C13 output receptacles for surge and battery backup protection)
5	Load segment 2 (two IEC-320-C13 output receptacles for surge and battery backup protection)
6	Voltage configuration DIP switches
7	Serial communications port
8	USB communications port

Item	Description
9	Input power connector (IEC-320-C14 power inlet)

Installation

Precautions

Save these instructions. This document contains important safety instructions that should be followed during installation, operation, and maintenance of the UPS and batteries.

-
-  **WARNING:** A risk of personal injury from electric shock and hazardous energy levels exists. The installation of options and routine maintenance and service of this product must be performed by individuals who are knowledgeable about the procedures, precautions, and hazards associated with AC power products.

 -  **WARNING:** To prevent personal injury from earth conductor leakage current:
 - Do not operate the UPS while disconnected from the utility power source.
 - Disconnect load devices before disconnecting the UPS from the utility power source.

 -  **WARNING:** To prevent personal injury, prepare the area and observe all materials handling procedures when transporting the UPS. When fully assembled, the UPS weighs 23 kg (50.5 lb).
-

Preparing to install the hardware

Before installing the hardware:

1. Be sure the necessary tools and materials ("[Tools required](#)" on page 11) are available.
2. Select an installation site ("[Selecting a site](#)" on page 11).
3. Prepare the equipment ("[Readying the equipment](#)" on page 12) for installation in the rack.

Tools required

A Philips screwdriver is required.

Selecting a site

-
-  **WARNING:** To prevent fire or electric shock, install the unit in a temperature- and humidity-controlled indoor environment, free of conductive contaminants.
-

When selecting a site, consider the following factors:

- Elevated operating ambient temperature—If the equipment is installed in a closed or multi-unit rack assembly, the operating ambient temperature of the rack environment might be greater than room ambient temperature. Install the equipment in an environment compatible with the operating temperature ("[Environmental specifications](#)" on page 38).

- Reduced air flow—In the rack, the rate of air flow required for safe operation of the equipment must not be compromised.
- Circuit overloading—Consideration should be given to the connection of the equipment to the supply circuit and the effect that overloading of the circuits might have on overcurrent protection and supply wiring. Appropriate consideration of equipment nameplate ratings should be used when addressing this concern.
- Reliable earthing—Reliable earthing of rack-mounted equipment should be maintained. Particular attention should be given to supply connections other than direct connections to the branch circuit, such as the use of power strips.
- Electrical requirements—All models require a dedicated (unshared) branch circuit, suitably rated for the specific UPS as stated in "Input specifications ("[UPS input specifications](#)" on page 36)" .

Readying the equipment

1. Check the battery recharge date specified on the label that is affixed to the shipping carton.



IMPORTANT: Do not use the battery if the recharge date has passed. If the date on the battery recharge date label has passed without the battery being recharged, contact an HP authorized service representative for directions.

2. Transport the packaged unit to its installation location.
3. Unpack the equipment near the rack where the unit will be assembled.



CAUTION: Always plan the rack installation so that the heaviest item is on the bottom of the rack. Install the heaviest item first, and continue to populate the rack from the bottom to the top.

Installing the mounting rails



WARNING: To reduce the risk of personal injury or damage to the equipment, be sure that:

- The leveling feet are extended to the floor.
 - The full weight of the rack rests on the leveling feet.
 - The stabilizing feet are attached to the rack if it is a single-rack installation.
 - The racks are coupled together in multiple-rack installations.
 - Only one component is extended at a time. A rack may become unstable if more than one component is extended for any reason.
-

1. Attach the side-mounting brackets to the unit.

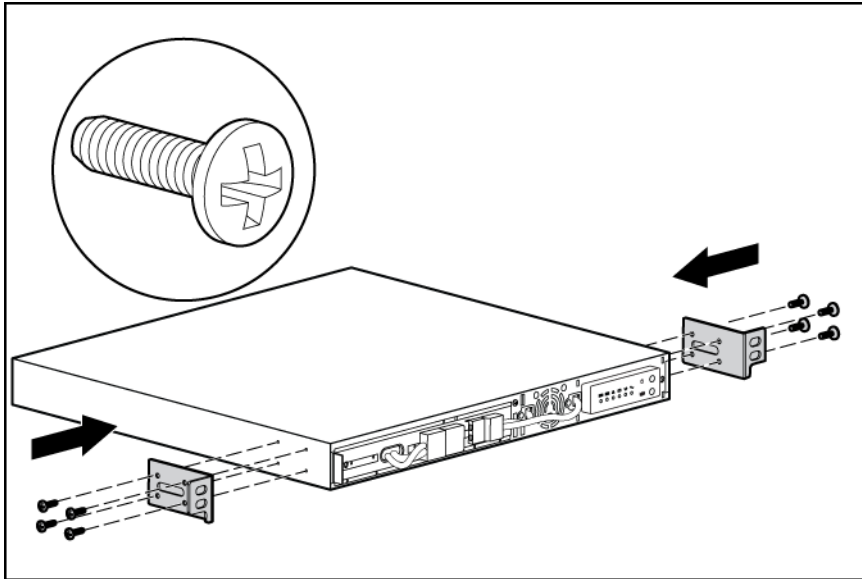

2. Loosen the wing nuts or hex nuts, and then extend the brackets to the desired length.

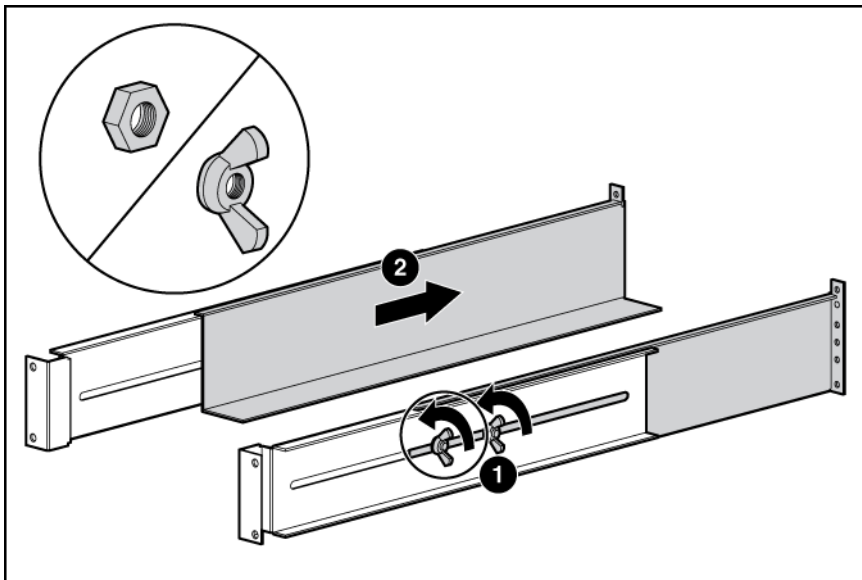

3. Use the cage nut tool to install cage nuts or clip nuts into the rear of the rack.

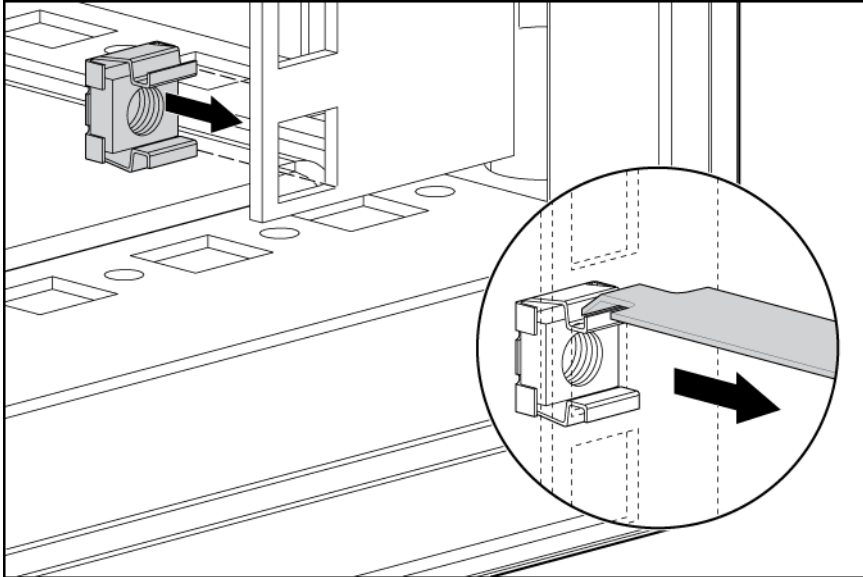

4. Insert screws through the mounting rail into the cage nuts or clip nuts.

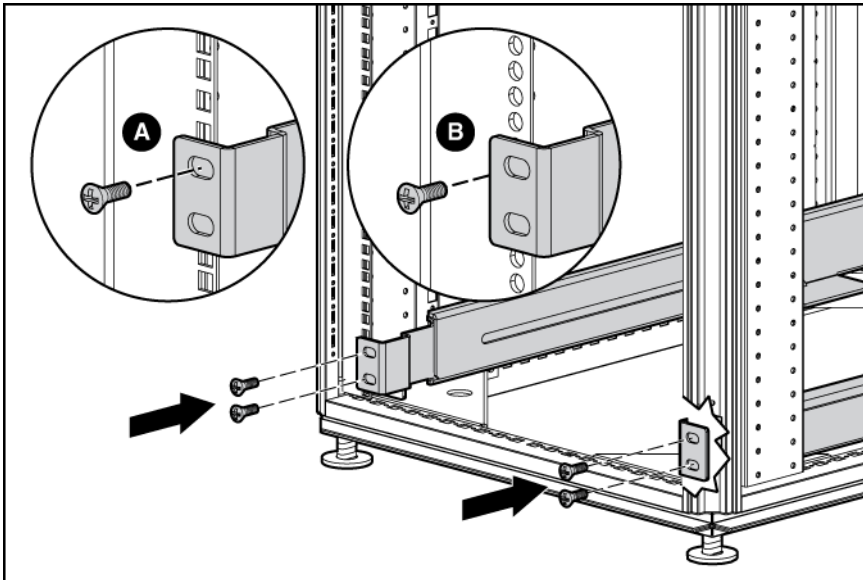

5. Use the cage nut tool to install cage nuts or clip nuts into the front of the rack.

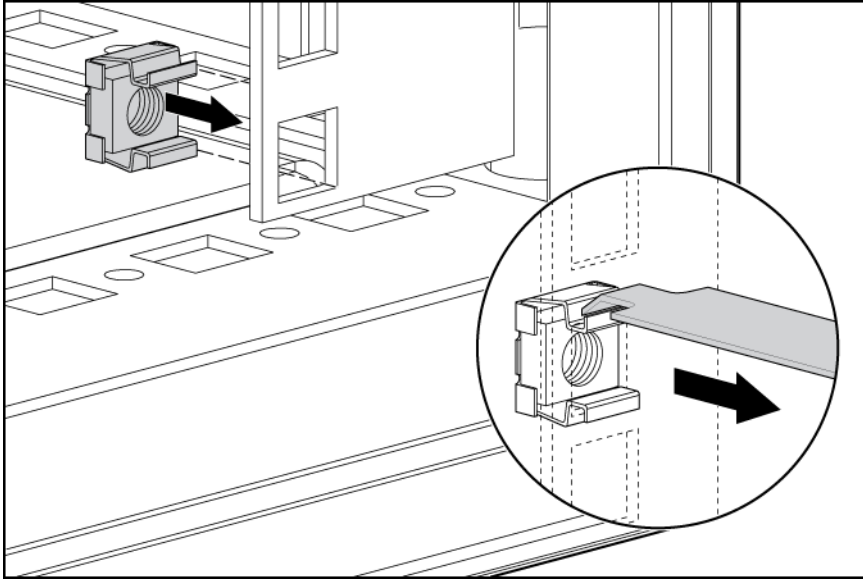

6. Insert a screw through the bottom hole of the mounting rail into the cage nuts or clip nuts.

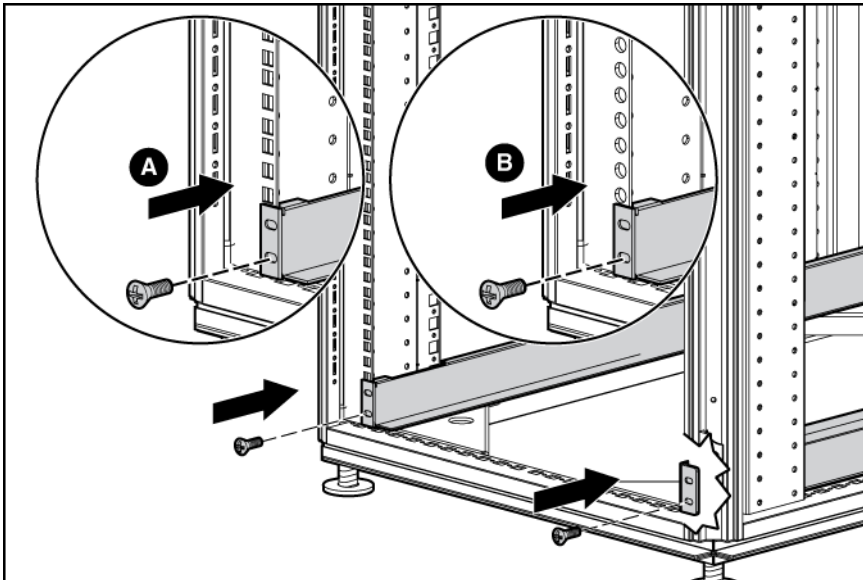

7. Tighten the wing nuts or hex nuts.

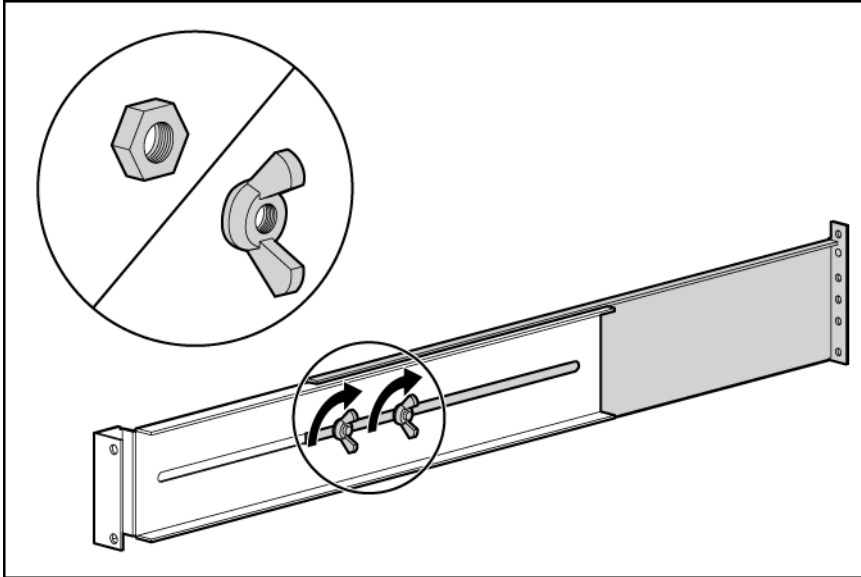

Installing the UPS

Before installing the unit, review and adhere to all warnings provided in "Precautions (on page 11)."

⚠ WARNING: A risk of personal injury or damage to the equipment exists. Uneven loading of equipment in the rack might cause the rack to become unstable. Install the heavier components first, and then continue to populate the rack from the bottom to the top.

1. Install the mounting rails ("Installing the mounting rails" on page 12).
2. Attach the chassis to the rack using the supplied screws.

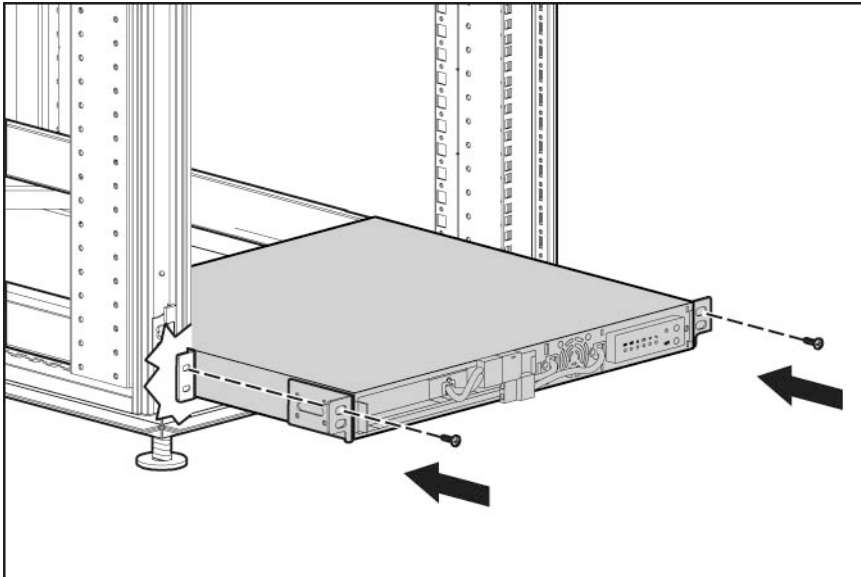

3. (optional) Insert the rear stabilization brackets into the mounting rails and then attach the brackets to the UPS.

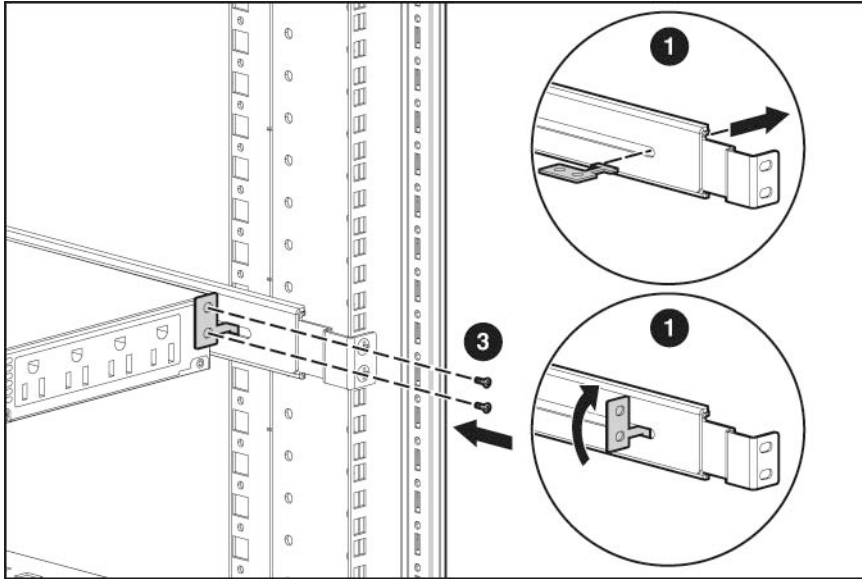

Connecting the batteries



WARNING: The unit contains sealed lead-acid battery modules. To prevent fire or chemical burns:

- Do not attempt to recharge batteries after removal from the unit.
- Do not disassemble, crush, or puncture the batteries.
- Do not short the external contacts of the batteries.
- Do not immerse the batteries in water.
- Do not expose to temperatures higher than 40°C (104°F).



WARNING: To prevent personal injury from hazardous energy:

- Remove watches, rings, or other metal objects.
- Use tools with insulated handles.
- Do not place tools or metal parts on top of batteries.



IMPORTANT: Before performing the following tasks, be sure that the unit is powered down and disconnected from the utility power source.

NOTE: A small amount of arcing may occur when connecting the batteries. This is normal and does not damage the unit or present any safety concern.

Connect the battery lead to the battery terminal.

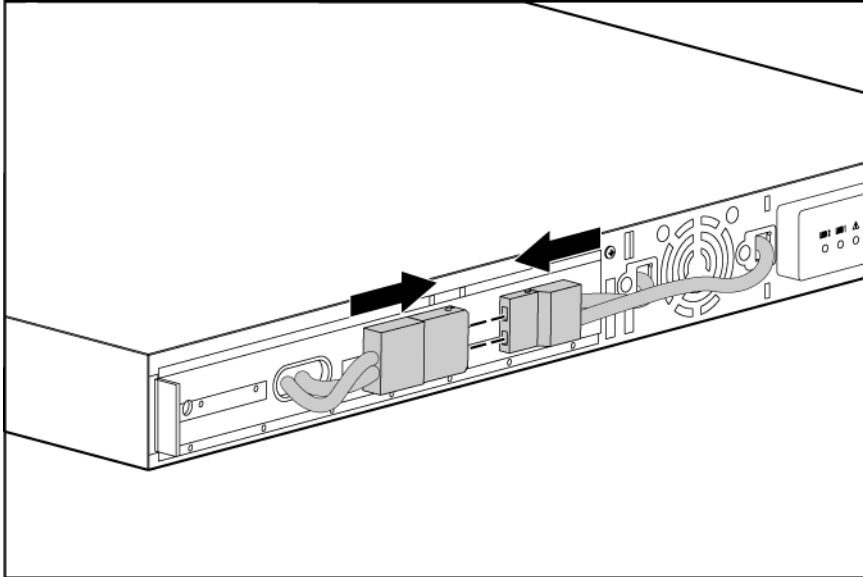

Attaching the UPS front bezel

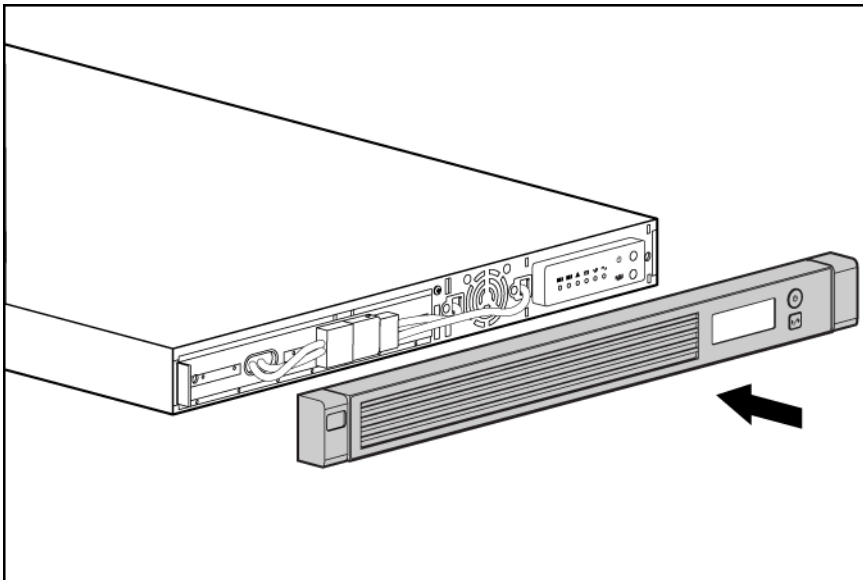

Selecting the UPS voltage configuration

Using a small tool, position the DIP switches according to the desired voltage configuration.

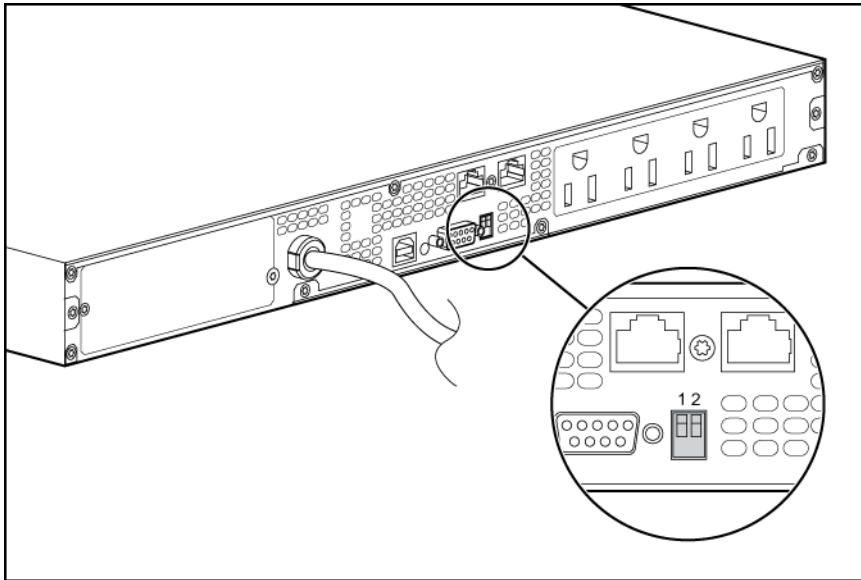

NOTE: An asterisk (*) indicates the default setting.

	Output voltage	Input voltage range	DIP switch 1	DIP switch 2
R1500 G2 JPN/TWN	100 V*	90–106 V	Down	Down
	110 V	99–116 V	Down	Up
R1500 G2 NA	110 V	99–116 V	Down	Up
	120 V*	108–127 V	Up	N/A
R1500 G2 INTL	220 V	198–233 V	Down	Up
	230 V*	207–243 V	Up	N/A
	240 V	216–254 V	Down	Down

Connecting the host computer

CAUTION: Only one communications port can be connected to the host computer. Connecting more than one will result in unexpected UPS behavior. If an option card is installed, the serial and USB communications ports are automatically disabled.

Connect the UPS to a host computer using either the USB cable or the DB9 serial cable included with the UPS. Install HP Power Manager software 4.0 or later on the host computer. See the HP website (<http://www.hp.com/go/rackandpower>) to download the latest version of HP Power Manager.

NOTE: To install and configure the software, see the software user guide. The software user guide is available for download from the HP website (<http://www.hp.com/go/rackandpower>).

Connecting the serial communications port

CAUTION: Use only the computer interface cable supplied with the UPS to connect the communications port to the host computer.

IMPORTANT: Power management software requires the communications port to be appropriately cabled to the host computer.

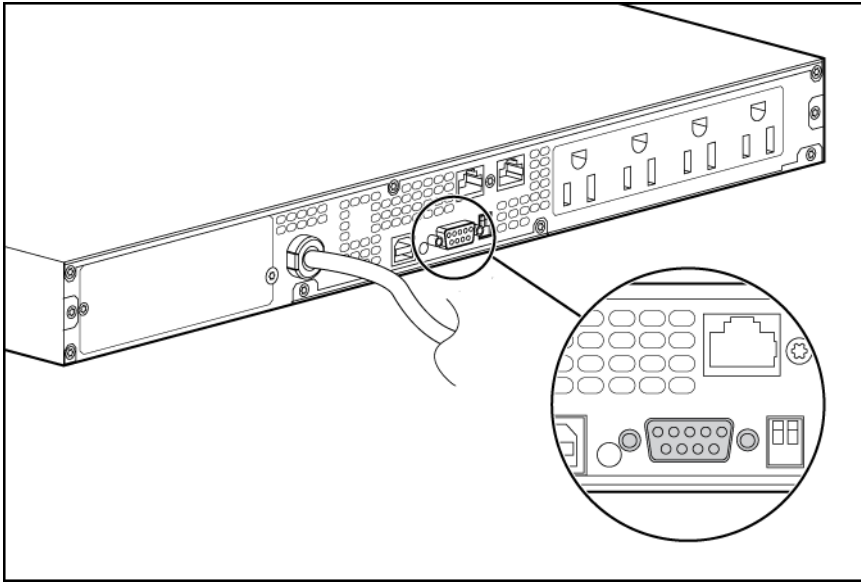

For information about serial port pin assignment, see "Serial communications port pin assignment (on page 38)" .

Connecting the USB communications port

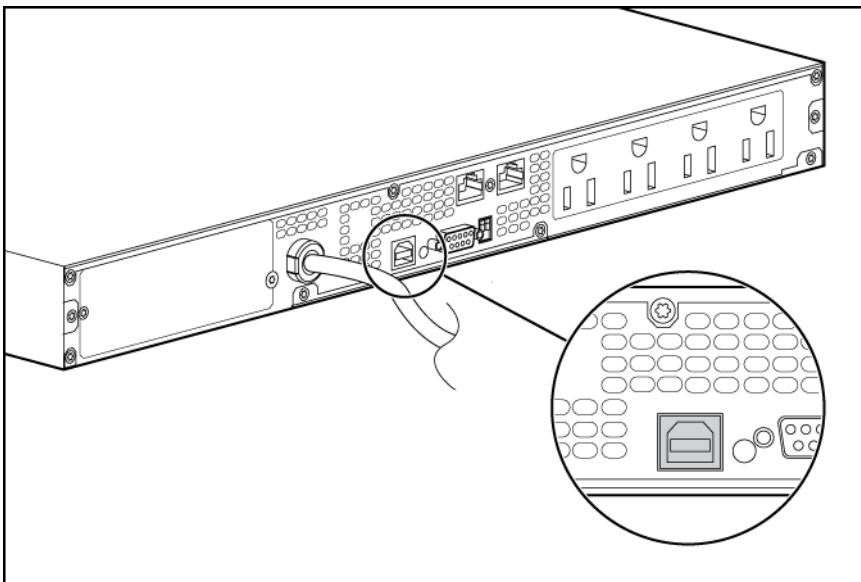

Connecting the Network Transient Protectors

-
- △ **CAUTION:** To avoid damaging the equipment, use the Network Transient Protector with a standard telephone line only, not with a digital PBX.
-

To protect equipment against surges over a network data line:

1. Connect the network wall jack to the UPS Network Transient Protector IN jack.
2. Connect the equipment to the UPS Network Transient Protector OUT jack.

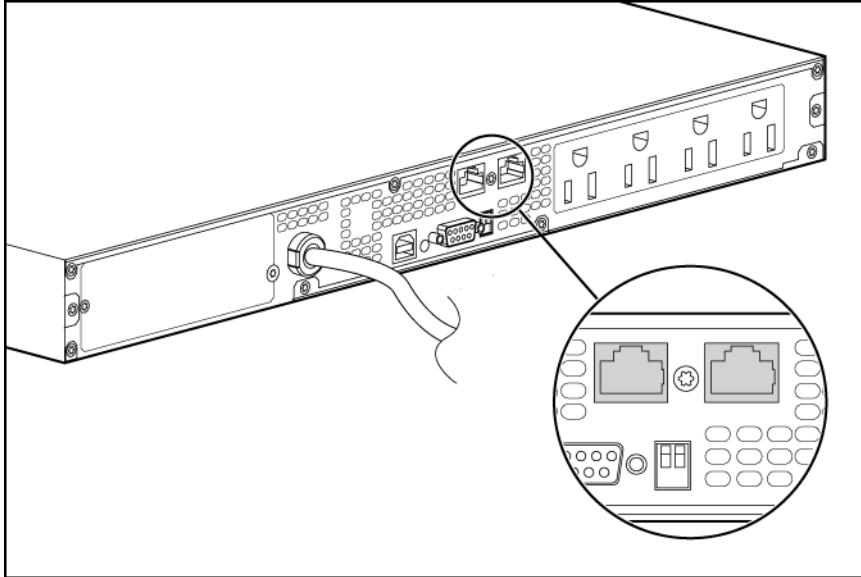

Connecting the UPS to utility power

-
- △ **WARNING:** To prevent injury from electric shock or damage to the equipment:
- Plug the input line cord into a grounded (earthed) electrical outlet that is installed near the equipment and is easily accessible.
 - Do not disable the grounding plug on the input line cord. The grounding plug is an important safety feature.
 - Do not use extension cords.
-

1. Connect the input power cord to the IEC-320-C14 input power connector on the UPS rear panel (INTL model only).
2. Connect the UPS power cord to a grounded utility power outlet. When the UPS is plugged in, the batteries begin to charge. Power to the output receptacles designated for surge and battery backup is not available until the unit is powered up.

For more information about receptacle control, see "Power management software (on page 25)".

Connecting devices to the UPS

-
- △ **CAUTION:** Do not plug laser printers into the UPS output receptacles. The instantaneous current drawn by this type of printer can overload the UPS.
-

Before connecting devices, verify that the UPS will not overload by checking that the ratings of the devices do not exceed the UPS capacity. If the equipment rating is listed in amps, multiply the number of amps by the selected output voltage to determine the VA.

After verifying that the UPS will not overload:

- Connect the device power cords to the output receptacles on the rear panel of the UPS (NA/JPN/TWN model).
- or-
- Connect devices to the output receptacles on the rear panel of the UPS using the jumper cords included with the UPS (INTL model).

Powering up the UPS

Press and hold the Power On/Standby button (1) until the UPS beeps. The Power On, Load 1 and Load 2 LEDs illuminate, indicating that power is available at the UPS output receptacles.

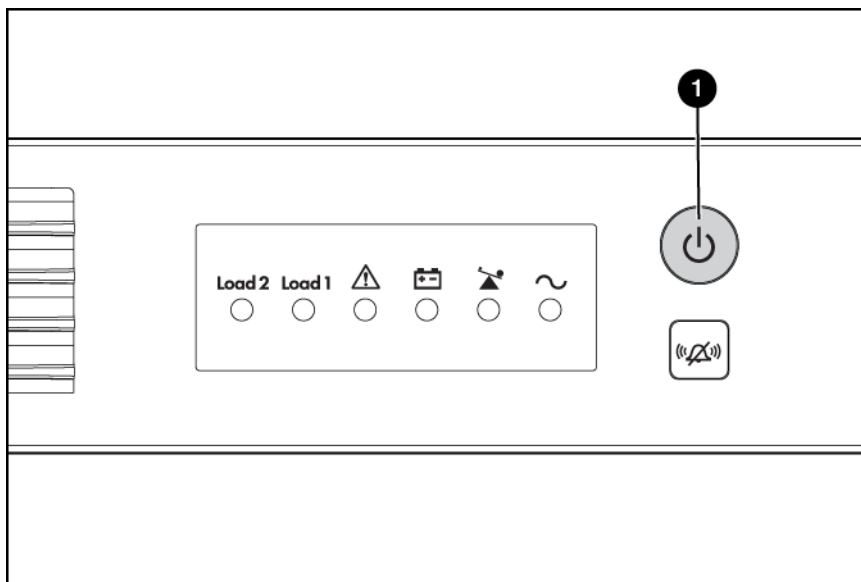

Charging the UPS batteries

With the UPS in Standby mode (on page 23), allow the batteries to charge before putting the UPS into service.



IMPORTANT: Charge the batteries for at least 24 hours before supplying backup power to devices. The batteries charge to:

- 90% of their capacity within 4 hours
- 100% of their capacity within 24 hours

UPS operations

Modes of operation

The UPS has three modes of operation:

- Standby mode (on page 23)
- Operate mode (on page 23)
- Battery mode (on page 24)

Standby mode

In Standby mode:

- No power is available at the UPS output receptacles.
- The UPS charges the batteries as necessary.

The UPS can be placed in Standby mode when the UPS is in Operate mode (the Power On LED ("UPS front panel LED indicators" on page 8) is illuminated).

To place the UPS in Standby mode, press and hold the Power On/Standby button ("UPS front panel controls" on page 7) until the audible alarm sounds. The Power On LED turns off and power to the load ceases.



IMPORTANT: While in Standby mode, the UPS maintains the charge on the batteries, but no power is available at the output receptacles. The UPS remains in Standby mode until an alternate mode is selected or until utility power is removed.

Operate mode

In Operate mode:

- Power is available at the UPS receptacles.
- The UPS charges the batteries as necessary.

The UPS can be placed in Operate mode if either of the following conditions applies:

- The UPS is powered up and in Standby mode (on page 23).
- The UPS is powered down and no utility power is available.

To place the UPS in Operate mode, press and hold the Power On/Standby button ("UPS front panel controls" on page 7) until the UPS acknowledges compliance with a short beep. The Power On, Load 1 and Load 2 LEDs ("UPS front panel LED indicators" on page 8) illuminate, indicating that power is available at the UPS output receptacles.

Battery mode

In Battery mode, the UPS supplies power without being connected to utility power.

To power up the UPS without using utility power, press and hold the Power On/Standby button ("UPS front panel controls" on page 7) for two seconds.

Initiating a self-test

To initiate a self-test, press and hold the Test/Alarm Reset button ("UPS front panel controls" on page 7) for three seconds.

Because a portion of the self-test requires battery power, the self-test cannot be initiated if the batteries are less than 90 percent charged. If the UPS detects a problem, the appropriate LED ("UPS front panel LED indicators" on page 8) illuminates and an audible alarm may sound.

For information on what to do if the self-test detects a problem, see "Troubleshooting (on page 33)."

Silencing an audible alarm

To silence an alarm, press the Test/Alarm Reset button ("UPS front panel controls" on page 7).



IMPORTANT:

- Although the audible alarm silences, the condition that caused the alarm to sound may still exist.
 - If a utility power failure caused the alarm (the Utility LED or the General Alarm LED illuminates red), the alarm silences after power is restored.
-

For information about audible alarm conditions, see "LED and audible alarm troubleshooting (on page 33)."

Powering down the UPS

1. Shut down all connected load devices.
2. Press the Power On/Standby button. Power to the output receptacles ceases.
3. Disconnect the UPS from utility power.
4. Wait at least 60 seconds for the UPS internal circuitry to discharge.

Power management

Power management software

HP Power Manager software ensures maximum power reliability of computer systems through comprehensive control of UPSs. The easy-to-use browser interface enables novice users to configure and manage power protection settings. To download the latest version of HP Power Manager software, see the HP website (<http://www.hp.com/go/rackandpower>).

NOTE: To install and configure the software, see the software user guide. The software user guide is available for download from the HP website (<http://www.hp.com/go/rackandpower>).

HP Power Manager:

- Does not require complex management systems, which simplifies deployment, configuration, and management of UPS-protected environments.
- Manages a graceful shutdown of attached devices during utility power failures.
- Prioritizes the timing of attached load device shutdowns.
- Shuts down and reboots any UPS and attached load devices based on a user-specified schedule.
- Customizes alert generation with modifiable dialog boxes, command execution, and email and broadcast messages.
- Monitors the status of the UPS and reports alarms.
- Displays a power log for analysis.
- Manages independent UPS load segments to provide separate power control of attached load devices.
- Delays reboot by load segment after a power outage to sequence the startup of system components.

Maintenance

Removing the UPS front bezel

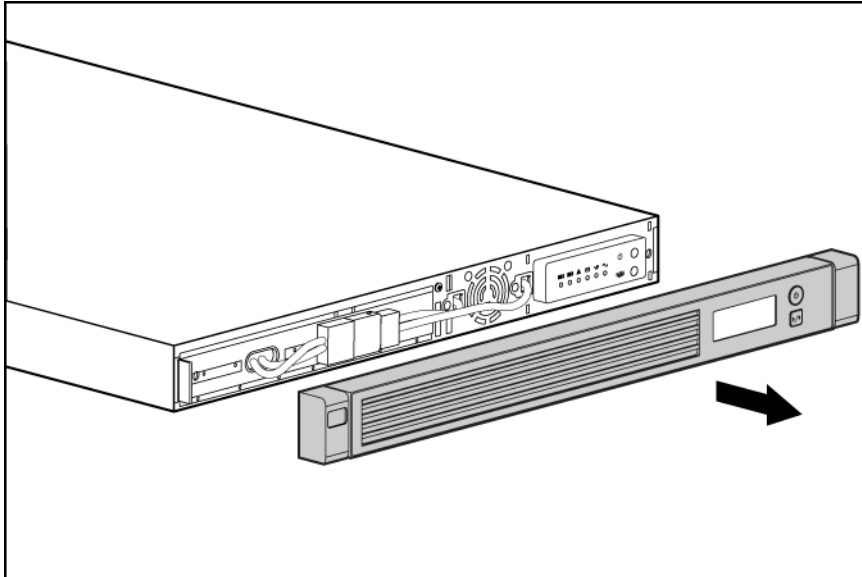

Replacing the UPS option card

This component is hot-swappable and can be replaced without powering down the UPS.

1. (optional) To replace the component with the UPS powered down, refer to "Powering down the UPS (on page 24)."
2. Remove the two screws securing the option card and slide the card out.

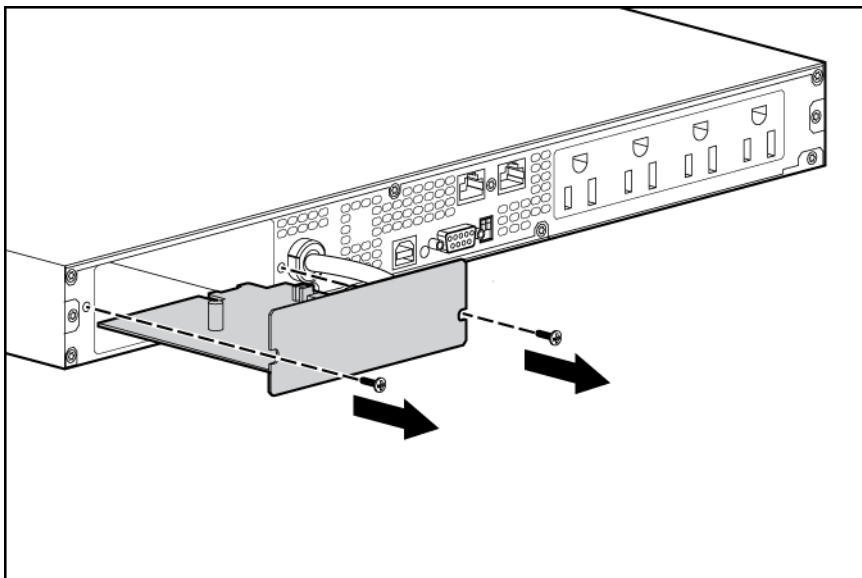

To replace the component, reverse the removal procedure.

 **CAUTION:** Only one communications port can be connected to the host computer. Connecting more than one will result in unexpected UPS behavior. If an option card is installed, the serial and USB communications ports are automatically disabled.

NOTE: Replacing the option card might require power management software to be restarted or reconfigured.

Replacing the batteries

To replace the batteries:

1. Read and observe the requirements in "Important battery safety information" and "Battery care and storage guidelines (on page 27)."
2. Follow the instructions in "UPS battery replacement procedure (on page 28)."

Important battery safety information

 **WARNING:** The unit contains sealed lead-acid battery modules. To prevent fire or chemical burns:

- Do not attempt to recharge batteries after removal from the unit.
 - Do not disassemble, crush, or puncture the batteries.
 - Do not short the external contacts of the batteries.
 - Do not immerse the batteries in water.
 - Do not expose to temperatures higher than 60°C (140°F).
-

 **WARNING:** To prevent personal injury from hazardous energy:

- Remove watches, rings, or other metal objects.
 - Use tools with insulated handles.
 - Do not place tools or metal parts on top of batteries.
-

NOTE: Replace all battery modules at the same time.

Battery care and storage guidelines

 **CAUTION:** Because of the short shelf life of the batteries, avoid storing a battery spare as a backup. Do not maintain an inventory of spare batteries on site unless a procedure to keep these batteries charged while in storage is implemented.

To maintain the batteries:

- Minimize the amount of time the UPS uses battery power by matching the UPS configuration with the utility voltage. See "Selecting the UPS voltage configuration (on page 19)."
- Keep the area around the UPS clean and dust-free. If the environment is very dusty, clean the outside of the UPS regularly with a vacuum cleaner.

- Maintain the ambient temperature at 25°C (77°F).
- If storing a UPS for an extended period, recharge the batteries ("[Charging the UPS batteries](#)" on page 22) every 6 months, and then update the battery recharge date label.

UPS battery replacement procedure

This component is hot-swappable and can be replaced without powering down the UPS.

1. (optional) To replace the component with the UPS powered down, refer to "Powering down the UPS (on page 24)."
2. Remove the UPS front bezel ("[Removing the UPS front bezel](#)" on page 26).
3. Disconnect the battery leads.

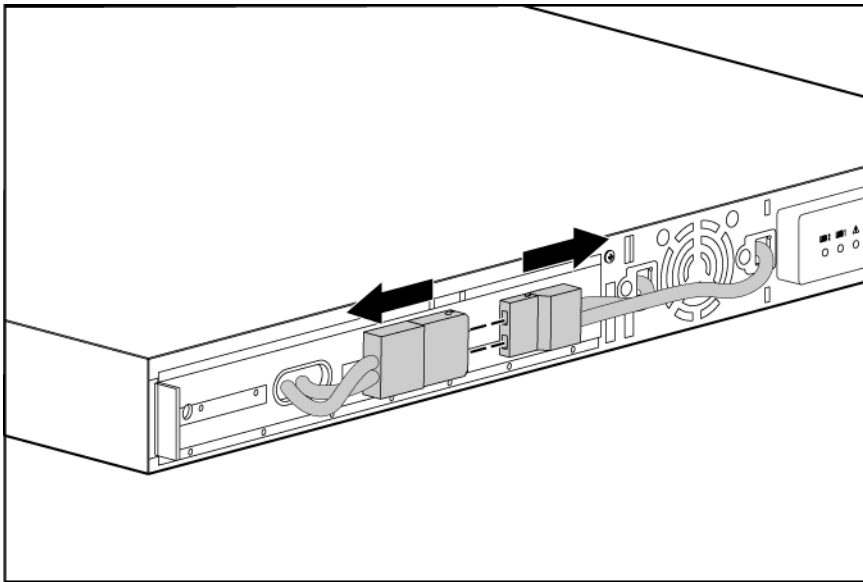

4. Remove the battery bracket.

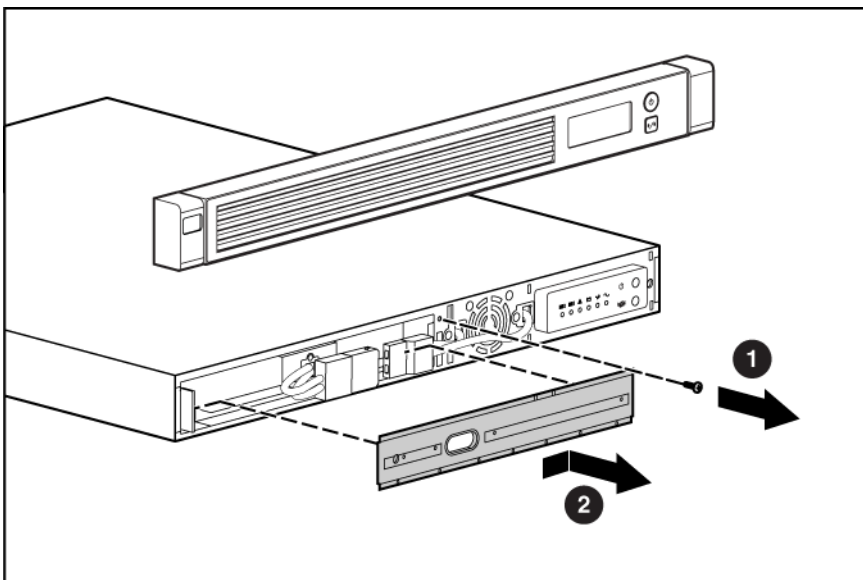

5. Remove the UPS battery modules.



IMPORTANT: Do not pull the battery leads when removing or installing the batteries.

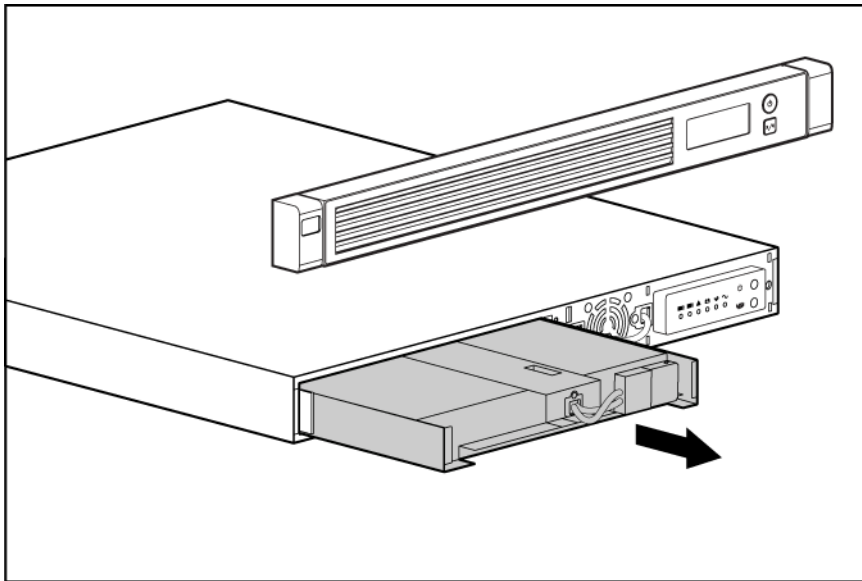

To replace the component, reverse the removal procedure.



IMPORTANT: Charge the batteries for at least 24 hours before supplying backup power to devices. The batteries charge to:

- 90% of their capacity within 4 hours
 - 100% of their capacity within 24 hours
-

Testing the new battery module

After installing the new battery module, press the Test/Alarm Reset button. For information on initiating a self-test, see "Initiating a self-test (on page 24)."



IMPORTANT: The UPS does not execute a self-test until the batteries are 90 percent charged.

If the installation has been successful, the UPS enters Operate mode. If the installation has not been successful, the alarm beeps, the On Battery LED illuminates and the General Alarm LED flashes. If this occurs, repeat the procedures in "Replacing the batteries (on page 27)," and check the battery terminal connections. If the condition persists, see "Troubleshooting (on page 33)."



IMPORTANT: Charge the batteries for at least 24 hours before supplying backup power to devices. The batteries charge to:

- 90% of their capacity within 4 hours
 - 100% of their capacity within 24 hours
-

Replacing the UPS

To remove the UPS:

1. Power down all attached load devices.

2. Power down the UPS ("Powering down the UPS" on page 24).
3. Unplug the UPS power cord.
4. Disconnect the communications cable.
5. Unplug the load devices.
6. Remove the UPS front bezel ("Removing the UPS front bezel" on page 26).
7. Remove the UPS battery bracket.
8. Remove the UPS battery modules.
9. Remove the screws securing the UPS to the rack.
10. Remove the UPS from the rack.

To replace the component, reverse the removal procedure.

Updating the UPS firmware

To update the UPS firmware, see the HP website (<http://www.hp.com/go/rackandpower>).

Configuring a USB to serial converter

NOTE: This procedure was tested on the Windows® XP Professional and Windows Server® 2003 operating systems using the HP USB to serial converter (part number 304098-001). Depending on your system configuration, a driver download might be required to successfully install the converter. The driver can be downloaded from the USB-Drivers website (<http://www.usb-drivers.com/drivers/123/123294.htm>).

To configure a USB port to the COM 1 port on systems that do not have available serial ports:

1. Connect the USB to serial converter to the USB port on your system.
2. Click **Start**, select **Control Panel**, and then double-click **System**.
The System Properties screen appears.
3. Click the **Hardware** tab.
4. Click **Device Manager**.
The Device Manager screen appears.
5. In the tree displayed in the left panel, click the **Ports (COM & LPT)** branch to expand.
6. Double-click the port that is assigned to your USB to serial converter device. This port is usually named with the device manufacturer's name followed by "USB to Serial Bridge (com 4)."
The Port Properties screen appears.
7. Click the **Port Settings** tab.
The Port Settings screen appears.
8. Click **Restore Defaults**.
The following default settings appear:
 - Bits per second: 9600
 - Data Bits: 8
 - Parity: None
 - Stop bits: 1

- o Flow control: None
9. Click **Advanced**.
The Advanced Settings screen appears.
 10. From the COM Port Number drop down menu, select **Com 1** for the USB port number.
If COM 1 is being used by another USB port, the following message appears:
This COM name is being used by another device. Using duplicate names can lead to inaccessible devices and changed settings. Do you want to continue?
 - a. Click **YES**.
 - b. Reassign the COM ports so that the USB to serial converter is using COM 1. See "Reassigning the USB COM ports."
 11. Reduce the Receive Buffer and Transmit Buffer to the low setting by scrolling down to select **low (1)**.
 12. Be sure that the **Use FIFO buffers (requires 16550 compatible UART)** checkbox is selected.
Depending on your operating system, the USB settings might be different. Choose the lowest, most dependable Receive and Transmit buffers by using the drop down menus, radio buttons, or other selection methods.
 13. Click **OK** to close the Advanced screen.
 14. Click **OK** to close the Device Manager screen.
 15. Run the firmware Flash batch file program. Follow the instructions provided with the program.

Reassigning the USB COM ports

To reassign a device from COM 1 to another port:

1. From the open Device Manager screen, locate the USB device that is assigned to COM 1.
2. Double-click the port name.
The Port Properties screen appears.
3. Click the **Port Settings** tab.
The Port Settings screen appears.
4. Click **Advanced**.
The Advanced Settings screen appears.
5. Select an available USB port number from the **COM Port Number** drop down menu.
6. Click **OK** to close the Advanced screen.
7. Click **OK** to close the Port Settings screen.
8. Verify that the Device Manager screen shows that the USB to serial converter is assigned to COM 1, and that the other USB device is assigned to a different port.
If the Device Manager screen does not automatically refresh to show the change:
 - a. Click **Action**.
The Action Menu appears.
 - b. Click **Scan for hardware changes** to refresh the screen and display the changes.

Cleaning battery spills

1. Put on acid-resistant boots, a chemical face shield, chemical splash goggles, and acid-resistant gloves.



WARNING: Battery acid can severely damage your eyes and skin.

2. Remove combustible materials and all sources of ignition.
3. Stop the flow of material and contain or absorb small spills with dry sand, earth, or vermiculite.
4. Neutralize spilled battery acid with the special solutions contained in a spill kit or with a solution of 1 lb baking soda to 1 gallon of water.
5. Be sure the mixture is neutral, then collect the residue and place the residue in a drum or other suitable container.
6. Properly dispose of hazardous waste.



WARNING: Do not allow discharge of unneutralized acid to reach the sewer.

Troubleshooting

LED and audible alarm troubleshooting

Condition	Power On LED (green)	On Battery LED (yellow)	Overload LED (red)	General Alarm LED (red)	Audible alarm	Can alarm be silenced ("Silencing an audible alarm" on page 24)?
UPS operating from utility	On	Off	Off	Off	No audible alarm	N/A
Buck mode (high input voltage)	On	Off	Off	Off	No audible alarm	N/A
Boost mode (low input voltage)	On	Off	Off	Off	No audible alarm	N/A
Over temperature condition	On	On	Off	Flashing	On—Continuous	No
Battery test failure	Off	On	Off	Flashing	On—Continuous	Yes
Fan failure	On	Off	Off	Flashing	On—Continuous	No
Output short circuit	On	On	On	Flashing	On—Continuous	No
Power up failure from a DC start— Low battery (no utility power)	Flashing	Flashing	Flashing	Flashing	On—3 beeps/10 seconds	No
Low battery (no utility power)	Off	Flashing	Off	Off	On—2 second beep	No
Online—UPS power capacity exceeded	On	Off	On	Off	On—1 second beep	No
Overload timeout	Off	Off	On	Flashing	On—Continuous	No
On battery—Input voltage is out of range	On	On	Off	Off	On—2 second beep	Yes
On battery—No utility power	Off	On	Off	Off	On—4 second beep	Yes
On battery—Battery voltage condition	Flashing	Off	Off	Flashing	On—Continuous	Yes
On battery—Overload condition	Off	On	On	Off	On—1 second beep	No

Condition	Power On LED (green)	On Battery LED (yellow)	Overload LED (red)	General Alarm LED (red)	Audible alarm	Can alarm be silenced ("Silencing an audible alarm" on page 24)?
On battery—Output voltage is out of range	Off	Flashing	Off	Flashing	On—Continuous	No
On battery—Output wave is abnormal	Flashing	Flashing	Off	Flashing	On—Continuous	No

For the location of individual LEDs, see "UPS front panel LED indicators (on page 8)."

UPS does not start

Action:

1. Be sure that the power cord is plugged in to a utility power receptacle.
2. Check the power source at the utility power receptacle.
3. Allow the UPS batteries to charge for 24 hours.

UPS operates on battery only

Action:

1. Save your work.
2. Power down the load devices connected to the UPS output receptacles.
3. Remove one or more load devices to reduce the power requirements.
4. Be sure the UPS configuration matches the utility voltage. Refer to "Selecting the UPS voltage configuration (on page 19)."

UPS frequently switches between utility and battery power

Action:

1. Check the input voltage and reconfigure the UPS ("[Selecting the UPS voltage configuration](#)" on page 19).
2. Contact a qualified electrician to verify that the utility power is suitable for the UPS.

UPS does not provide the expected backup time

Action:

1. If the Overload LED is illuminated, remove one or more load devices to reduce the power requirements.
2. Power down the UPS ("[Powering down the UPS](#)" on page 24).
3. Verify the batteries are connected.
4. Allow the UPS batteries to charge for 24 hours.
5. Initiate a self-test ("[Initiating a self-test](#)" on page 24).
6. During extended power outages, save your work, power down the load devices, and then power down the UPS ("[Powering down the UPS](#)" on page 24) to conserve battery power.

UPS cannot communicate with the host computer

Action:

- Verify only one communications port is connected to the host computer ("[Connecting the host computer](#)" on page 19).
- If an option card is installed, verify the host computer is only connected to the option card. Installing an option card automatically disables the built-in serial and USB communications ports.

UPS emits a slight clicking noise

Action: The UPS is automatically correcting high or low AC voltage on the utility line. No action is required.

Site wiring condition

Action: Contact a qualified electrician to be sure that:

- The utility power receptacle is grounded.
- There is a ground wire in the UPS power cord.
- The line and neutral wires are not reversed in the wall outlet.

Specifications

UPS physical specifications

Parameter	Value
Height	4.5 cm (1.75 in)
Depth	57.8 cm (22.8 in)
Width	44 cm (17.3 in)
Weight	23 kg (50.5 lb)

UPS input specifications

NOTE: An asterisk (*) indicates the default setting.

UPS model	Utility voltage frequency (auto-sensing)	Available settings utility voltage ("Selecting the UPS voltage configuration" on page 19) (VAC)	Branch circuit rating (A)	Line cord
R1500 G2 NA	50/60 Hz	110, 120*	15 or 20	Power cord with NEMA 5-15 plug
R1500 G2 JPN/TWN	50/60 Hz	100*, 110	15 or 20	Power cord with NEMA 5-15 plug (BSMI approved for TWN)
R1500 G2 INTL	50/60 Hz	220, 230*, 240	16	IEC-320-C14 power inlet

UPS output specifications

UPS model	Output receptacles
R1500 G2 NA/JPN/TWN	4 x NEMA 5-15
R1500 G2 INTL	4 x IEC-320-C13

Power protection specifications

UPS model	VA	Nominal power rating (W)	Nominal voltage setting
R1500 G2 NA	1440	1000	110, 120
R1500 G2 JPN/TWN	1200	900	100
	1440	1000	110
R1500 G2 INTL	1500	1000	220, 230, 240

Voltage specifications

Configuration setting (VAC)	Available nominal output voltage (VAC)
100	100
110	110
120	120
220	220
230	230
240	240

Output tolerance specifications

Source of power	Regulation
Utility power (nominal range)	-10% to +6% of nominal output voltage rating (within the guidelines of the Computer Business Equipment Manufacturers Association)
Battery power	±20% of nominal output voltage rating

Output feature specifications

Feature	Specification
Online efficiency	95% nominal input voltage
Voltage wave shape	Sine wave; 5% THD with typical PFC load
Surge suppression	ANSI C62.41 Category A (formerly IEEE 587)
Noise filtering	Full-time EMI/RFI filtering

Battery specifications

Feature	Specification
Type	6 V, 9 AH, sealed, maintenance-free, valve-regulated, rechargeable, lead-acid battery.
Voltage	The battery modules have a battery string voltage of 36 V.

Feature	Specification
Charging	Advanced charging for faster recovery. Complete charge takes no more than 24 hours. After approximately 4 hours, the batteries reach 90% charge at default nominal utility voltage and no load.

Battery runtime

Load, percent	Load, watts	Estimated battery runtime at 100% battery charge
20	200	58 minutes
50	500	17 minutes
80	800	8 minutes
100	1000	5 minutes

Environmental specifications

Feature	Specification
Operating temperature	0°C to 35°C (32°F to 95°F)
Nonoperating temperature	-15°C to 55°C (5°F to 131°F)
Relative humidity	5% to 95%; noncondensing
Operating altitude	Up to 3,000 m (9,843 ft) above sea level
Nonoperating altitude	Up to 15,000 m (49,212 ft) above sea level
Audible noise	Less than 45 dBA

Serial communications port pin assignment

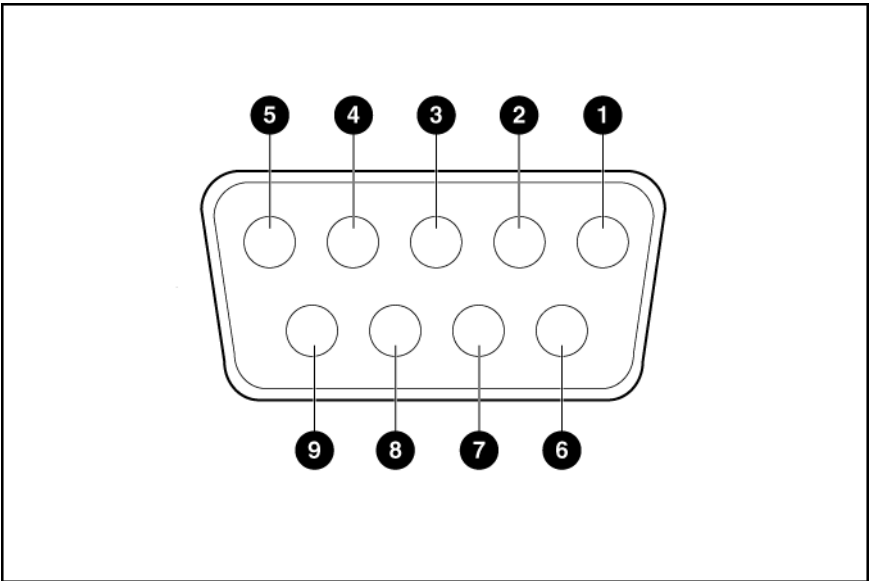

Pin number	Signal name	Function	Direction from the UPS
1	Low batt	Low battery relay contact; 20 mA, 30 Vdc contact rating	Out
2	TxD	Transmit to external device	Out
3	RxD	Receive from external device	In
4	DTR	PnP from external device (tied to Pin 6)	In
5	GND	Signal common (tied to chassis)	—
6	DSR	To external device (tied to Pin 4)	Out
7	—	No connection	—
8	AC fail	AC fail relay contact; 20 mA, 30 Vdc contact rating	Out
9	—	No connection	—

Spares

Ordering spares

To order a spare, visit the HP website (<http://www.hp.com/buy/parts>).

To replace parts under warranty, contact an HP authorized service representative.

UPS spare parts list

Item	Spare part number
UPS unit NA	418400-001
UPS unit JPN/TWN	419011-291
UPS unit INTL	419012-B31
Battery	418401-001

Hardware options

For information on the supported hardware options, see the HP website (<http://www.hp.com/go/rackandpower>).

Technical support

Before you contact HP

Be sure to have the following information available before you call HP:

- Technical support registration number (if applicable)
- Product serial number
- Product model name and number
- Product identification number
- Applicable error messages
- Add-on boards or hardware
- Third-party hardware or software
- Operating system type and revision level

HP contact information

For the name of the nearest HP authorized reseller:

- See the Contact HP worldwide (in English) webpage (<http://welcome.hp.com/country/us/en/wwcontact.html>).

For HP technical support:

- In the United States, for contact options see the Contact HP United States webpage (http://welcome.hp.com/country/us/en/contact_us.html). To contact HP by phone:
 - Call 1-800-HP-INVENT (1-800-474-6836). This service is available 24 hours a day, 7 days a week. For continuous quality improvement, calls may be recorded or monitored.
 - If you have purchased a Care Pack (service upgrade), call 1-800-633-3600. For more information about Care Packs, refer to the HP website (<http://www.hp.com/hps>).
- In other locations, see the Contact HP worldwide (in English) webpage (<http://welcome.hp.com/country/us/en/wwcontact.html>).

Warranty information

Limited warranty

To back up the wide range of features offered with the UPS, a 3-year limited warranty is provided.

\$250,000 Computer Load Protection Guarantee

In addition to the limited warranty, a \$250,000 Computer Load Protection Guarantee (provided by the original equipment manufacturer) is offered.



IMPORTANT: The \$250,000 Computer Load Protection Guarantee is offered only in The United States and Canada.

The \$250,000 Computer Load Protection Guarantee only applies if:

- The UPS is plugged into a suitably grounded and wired outlet using no extension cords, adapters, other ground wires, or other electrical connections.
- The UPS installation complies with all applicable electrical and safety codes specified by the NEC.
- The UPS is used under normal operating conditions and users comply with all instructions and labels.
- The UPS is not damaged by accident (other than a utility power transient), misuse, or abuse.
 - The Guarantee applies only to the original end-user and is non-transferable.
 - The Guarantee does not include reimbursement for or restoration of any data loss.
- The UPS is either connected directly to an enterprise class PDU, which is then connected directly to a server, workstation, or personal computer, or the UPS is connected directly to a server, workstation, or personal computer.

Pre-Failure Battery Warranty

The Pre-Failure Battery Warranty, standard on all UPS units, extends the advantage of a 3-year limited warranty by applying it to the battery before it actually fails. The Pre-Failure Battery Warranty ensures that the battery is replaced free of charge when a notification that the battery might fail is received from power management software. The battery warranty coverage is 3 years for parts. The warranty for the first year of ownership includes parts and labor. If battery spares are not available for a particular UPS model, the entire UPS, including its battery, is replaced.

A Pre-Failure Battery warning is given 30 days before a battery failure. The warning is indicated in one or both of the following ways:

- An LED showing the battery is low
- Notification from power management software

Recommended duration of use

Although tests and a multitude of customer experiences have shown no noticeable performance issues with UPSs for significant time periods after expiration of the 3-year limited warranty, we strongly recommend considering replacing UPSs after a maximum of 5 to 6 years of use to assure full functionality and a safe operating environment. This recommendation does not extend or in any way alter the warranty for UPSs which is limited to a time period of 3 years and a coverage as stated in the applicable warranty statement.

Regulatory compliance notices

Regulatory compliance identification numbers

For the purpose of regulatory compliance certifications and identification, this product has been assigned a unique regulatory model number. The regulatory model number can be found on the product nameplate label, along with all required approval markings and information. When requesting compliance information for this product, always refer to this regulatory model number. The regulatory model number is not the marketing name or model number of the product.

Federal Communications Commission notice

Part 15 of the Federal Communications Commission (FCC) Rules and Regulations has established Radio Frequency (RF) emission limits to provide an interference-free radio frequency spectrum. Many electronic devices, including computers, generate RF energy incidental to their intended function and are, therefore, covered by these rules. These rules place computers and related peripheral devices into two classes, A and B, depending upon their intended installation. Class A devices are those that may reasonably be expected to be installed in a business or commercial environment. Class B devices are those that may reasonably be expected to be installed in a residential environment (for example, personal computers). The FCC requires devices in both classes to bear a label indicating the interference potential of the device as well as additional operating instructions for the user.

FCC rating label

The FCC rating label on the device shows the classification (A or B) of the equipment. Class B devices have an FCC logo or ID on the label. Class A devices do not have an FCC logo or ID on the label. After you determine the class of the device, refer to the corresponding statement.

Class A equipment

This equipment has been tested and found to comply with the limits for a Class A digital device, pursuant to Part 15 of the FCC Rules. These limits are designed to provide reasonable protection against harmful interference when the equipment is operated in a commercial environment. This equipment generates, uses, and can radiate radio frequency energy and, if not installed and used in accordance with the instructions, may cause harmful interference to radio communications. Operation of this equipment in a residential area is likely to cause harmful interference, in which case the user will be required to correct the interference at personal expense.

Class B equipment

This equipment has been tested and found to comply with the limits for a Class B digital device, pursuant to Part 15 of the FCC Rules. These limits are designed to provide reasonable protection against harmful interference in a residential installation. This equipment generates, uses, and can radiate radio frequency energy and, if not installed and used in accordance with the instructions, may cause harmful interference

to radio communications. However, there is no guarantee that interference will not occur in a particular installation. If this equipment does cause harmful interference to radio or television reception, which can be determined by turning the equipment off and on, the user is encouraged to try to correct the interference by one or more of the following measures:

- Reorient or relocate the receiving antenna.
- Increase the separation between the equipment and receiver.
- Connect the equipment into an outlet on a circuit that is different from that to which the receiver is connected.
- Consult the dealer or an experienced radio or television technician for help.

Declaration of conformity for products marked with the FCC logo, United States only

This device complies with Part 15 of the FCC Rules. Operation is subject to the following two conditions: (1) this device may not cause harmful interference, and (2) this device must accept any interference received, including interference that may cause undesired operation.

For questions regarding this product, contact us by mail or telephone:

- Hewlett-Packard Company
P. O. Box 692000, Mail Stop 530113
Houston, Texas 77269-2000
- 1-800-HP-INVENT (1-800-474-6836). (For continuous quality improvement, calls may be recorded or monitored.)

For questions regarding this FCC declaration, contact us by mail or telephone:

- Hewlett-Packard Company
P. O. Box 692000, Mail Stop 510101
Houston, Texas 77269-2000
- 1-281-514-3333

To identify this product, refer to the part, series, or model number found on the product.

Modifications

The FCC requires the user to be notified that any changes or modifications made to this device that are not expressly approved by Hewlett-Packard Company may void the user's authority to operate the equipment.

Cables

Connections to this device must be made with shielded cables with metallic RFI/EMI connector hoods in order to maintain compliance with FCC Rules and Regulations.

Canadian notice (Avis Canadien)

Class A equipment

This Class A digital apparatus meets all requirements of the Canadian Interference-Causing Equipment Regulations.

Cet appareil numérique de la classe A respecte toutes les exigences du Règlement sur le matériel brouilleur du Canada.

Class B equipment

This Class B digital apparatus meets all requirements of the Canadian Interference-Causing Equipment Regulations.

Cet appareil numérique de la classe B respecte toutes les exigences du Règlement sur le matériel brouilleur du Canada.

European Union regulatory notice

This product complies with the following EU Directives:

- Low Voltage Directive 2006/95/EC
- EMC Directive 2004/108/EC

Compliance with these directives implies conformity to applicable harmonized European standards (European Norms) which are listed on the EU Declaration of Conformity issued by Hewlett-Packard for this product or product family.

This compliance is indicated by the following conformity marking placed on the product:



This marking is valid for non-Telecom products and EU harmonized Telecom products (e.g. Bluetooth).



This marking is valid for EU non-harmonized Telecom products.

*Notified body number (used only if applicable—refer to the product label)

Hewlett-Packard GmbH, HQ-TRE, Herrenberger Strasse 140, 71034 Boeblingen, Germany

The official EU CE declaration of conformity for this device can be found on the HP website (<http://www.hp.com/go/certificates>).

Disposal of waste equipment by users in private households in the European Union



This symbol on the product or on its packaging indicates that this product must not be disposed of with your other household waste. Instead, it is your responsibility to dispose of your waste equipment by handing it over to a designated collection point for the recycling of waste electrical and electronic equipment. The separate collection and recycling of your waste equipment at the time of disposal will help to conserve natural resources and ensure that it is recycled in a manner that protects human health and the environment. For more information about where you can drop off your waste equipment for recycling, please contact your local city office, your household waste disposal service or the shop where you purchased the product.

Japanese notice

JAPANESE NOTICE

ご使用になっている装置に VCCI マークが付いていましたら、次の説明文をお読み下さい。

この装置は、クラス B 情報技術装置です。この装置は、家庭環境で使用することを目的としていますが、この装置がラジオやテレビジョン受信機に近接して使用されると、受信障害を引き起こすことがあります。取扱説明書に従って正しい取り扱いをして下さい。

VCCI-B

VCCI マークが付いていない場合には、次の点にご注意下さい。

この装置は、クラス A 情報技術装置です。この装置を家庭環境で使用すると電波妨害を引き起こすことがあります。この場合には使用者は適切な対策を講ずるよう要求されることがあります。

VCCI-A

April 1, 2009

BSMI notice

警告使用者:

這是甲類的資訊產品，在居住的環境中使用時，可能會造成射頻干擾，在這種情況下，使用者會被要求採取某些適當的對策。

Korean notice

Class A equipment

A급 기기 (업무용 방송통신기기)	이 기기는 업무용(A급)으로 전자파적합등록을 한 기기이오니 판매자 또는 사용자는 이 점을 주의하시기 바라며, 가정 외의 지역에서 사용하는 것을 목적으로 합니다.
-----------------------	---

Class B equipment

B급 기기 (가정용 방송통신기기)	이 기기는 가정용(B급)으로 전자파적합등록을 한 기기로서 주로 가정에서 사용하는 것을 목적으로 하며, 모든 지역에서 사용할 수 있습니다.
-----------------------	--

Battery replacement notice



WARNING: Power products contain sealed lead-acid battery modules. A risk of fire and burns exists if the battery is not properly handled. To reduce the risk of personal injury:

- Do not attempt to recharge the battery.
- Do not expose the battery to temperatures higher than 60°C (140°F).
- Do not disassemble, crush, puncture, short external contacts, or dispose of in fire or water. The battery might explode.



Batteries, battery packs, and accumulators should not be disposed of together with the general household waste. To forward them to recycling or proper disposal, use the public collection system or return them to HP, an authorized HP Partner, or their agents.

For more information about battery replacement or proper disposal, contact an authorized reseller or an authorized service provider.

Power cord statement for Japan

製品には、同梱された電源コードをお使い下さい。
同梱された電源コードは、他の製品では使用出来ません。

Electrostatic discharge

Preventing electrostatic discharge

To prevent damaging the system, be aware of the precautions you need to follow when setting up the system or handling parts. A discharge of static electricity from a finger or other conductor may damage system boards or other static-sensitive devices. This type of damage may reduce the life expectancy of the device.

To prevent electrostatic damage:

- Avoid hand contact by transporting and storing products in static-safe containers.
- Keep electrostatic-sensitive parts in their containers until they arrive at static-free workstations.
- Place parts on a grounded surface before removing them from their containers.
- Avoid touching pins, leads, or circuitry.
- Always be properly grounded when touching a static-sensitive component or assembly.

Grounding methods to prevent electrostatic discharge

Several methods are used for grounding. Use one or more of the following methods when handling or installing electrostatic-sensitive parts:

- Use a wrist strap connected by a ground cord to a grounded workstation or computer chassis. Wrist straps are flexible straps with a minimum of 1 megohm ± 10 percent resistance in the ground cords. To provide proper ground, wear the strap snug against the skin.
- Use heel straps, toe straps, or boot straps at standing workstations. Wear the straps on both feet when standing on conductive floors or dissipating floor mats.
- Use conductive field service tools.
- Use a portable field service kit with a folding static-dissipating work mat.

If you do not have any of the suggested equipment for proper grounding, have an authorized reseller install the part.

For more information on static electricity or assistance with product installation, contact an authorized reseller.

Acronyms and abbreviations

IEC

International Electrotechnical Commission

LED

light-emitting diode

NEC

National Electrical Code

NEMA

National Electrical Manufacturers Association

PFC

power factor corrected

PnP

plug and play

UPS

uninterruptible power system

USB

universal serial bus

Index

A

- alarm cannot be silenced 33
- alarm conditions 33
- alarms, silencing 24
- alarms, troubleshooting 33
- authorized reseller 41

B

- backup time, insufficient 34
- batteries, care and storage 27
- batteries, charging 22
- batteries, cleaning spills 32
- batteries, connecting 17
- batteries, replacing 27, 28
- batteries, runtime 38
- batteries, specifications 37
- batteries, testing 29
- battery bracket 28
- battery cables, connecting 17
- Battery mode 24
- battery replacement notice 48
- battery warranty 42
- bezel, attaching 18
- bezel, removing 28
- BSMI notice 48
- buttons 6, 7

C

- cables 45
- cables, battery 17
- cabling, USB 20
- Canadian notice 46
- charging batteries 22
- class A equipment 44
- class B equipment 44
- communications port, connecting 20
- components, identification 6, 7, 8, 9
- components, rear 8, 9
- configuring components 19
- connecting batteries 17
- contacting HP 41

D

- Declaration of Conformity 45
- devices, connecting 21
- diagnostics 24
- dimensions, UPS 36
- DIP switches, location 8, 9
- DIP switches, setting 19
- disposal, battery 46, 48
- duration of use 43

E

- electrical requirements 11
- electrostatic discharge 50
- environmental specifications 38
- European Union notice 46

F

- FCC rating label 44
- Federal Communications Commission (FCC)
notice 44, 45
- firmware, updating 30
- frequent switching between battery and utility
power 34
- front panel buttons 7
- front panel components 6
- front panel LEDs 8

G

- General Alarm LED, location 8
- General Alarm LED, troubleshooting 33
- grounding methods 50

H

- hardware options 40
- hardware, preparing to install 11
- HP Power Manager 25
- HP technical support 41

I

- input circuit breaker, location 9

- input specifications 36
- installation instructions 11, 16
- installing the batteries 28
- installing the rails 12
- installing the UPS 16
- insufficient backup time 34
- International model 9

J

- Japanese notice 47

K

- Korean notices 48

L

- LEDs, testing 24
- LEDs, troubleshooting 33
- LEDs, unit identification (UID) 8
- limited warranty 42
- load protection guarantee 42
- Load Segment 1 LED 8
- Load Segment 2 LED 8
- load segments, controlling 25
- load segments, location 8, 9
- load segments, specifications 36
- low-voltage UPS 8

M

- maintenance 26
- models, high-voltage UPS 9
- models, low-voltage UPS 8
- modes of operation 23
- modifications, FCC notice 45
- mounting rails 12

N

- network transient protectors 20
- nominal voltage, configuring 19

O

- On Battery LED, location 8
- On Battery LED, troubleshooting 33
- On button, location 7
- Operate mode 23
- operations, UPS 23
- option card, replacing 26
- ordering spares 40

- output feature specifications 37
- output specifications 36
- output tolerance specifications 37
- Overload LED, location 8
- Overload LED, troubleshooting 33
- overview, HP Power Manager 25
- overview, power management software 25
- overview, UPS 6

P

- phone numbers 41
- physical specifications 36
- pin assignment 38
- power cord 49
- power LED, location 8
- Power LED, troubleshooting 33
- power management 25
- Power On/Standby button 7
- power protection specifications 37
- powering down 24
- powering up 22
- preparation procedures 11
- problem diagnosis 33

R

- rails, installing 12
- rear panel components 8, 9
- recommended duration of use 43
- regulatory compliance identification numbers 44
- regulatory compliance notices 44, 46
- replacing the batteries 27, 28
- replacing the option card 26
- replacing the UPS 29
- required information 41
- required tools 11
- runtime specifications 38

S

- safety considerations 11
- selecting a site 11
- serial port 20
- series number 44
- shipping the UPS 12
- site requirements 11
- Site Wiring Fault LED, location 8
- software 25
- spare part numbers 40
- spares 40
- specifications 36

- Standby button, location 7
- Standby mode 23
- static electricity 50
- storing batteries 27
- support 41
- supported hardware 40
- supported software 25
- system configuration settings 19

T

- technical support 41
- telephone numbers 41
- temperature ranges (environmental) 38
- Test/Alarm Reset button, location 7
- testing batteries 29
- testing LEDs 24
- tools 11
- troubleshooting 33

U

- Uninterruptible Power System, high-voltage models 9
- Uninterruptible Power System, low-voltage models 8
- unpacking the components 12
- updating the firmware 30
- UPS does not start 34
- UPS firmware, updating 30
- UPS operations 23
- UPS, installing 11, 16
- UPS, replacing 29
- USB connectors 20
- utility power, connecting 21

V

- voltage specifications 37
- voltage, configuring 19

W

- warranties 42
- weight, UPS 36