

Manual Addendum

Model T265 *Chemiluminescence Ozone Analyzer*

(Addendum to Model T200 Operation Manual PN 06858)

© TELEDYNE ADVANCED POLLUTION INSTRUMENTATION
9480 CARROLL PARK DRIVE
SAN DIEGO, CA 92121-5201
USA

Toll-free Phone: 800-324-5190
Phone: 858-657-9800
Fax: 858-657-9816
Email: api-sales@teledyne.com
Website: <http://www.teledyne-api.com/>

IMPORTANT SAFETY INFORMATION

Important safety messages are provided throughout this manual for the purpose of avoiding personal injury or instrument damage. Please read these messages carefully. Each safety message is associated with a safety alert symbol and placed throughout this manual and inside the instrument. The symbols with messages are defined as follows:



WARNING: Electrical Shock Hazard



HAZARD: Strong oxidizer



GENERAL WARNING/CAUTION: Read the accompanying message for specific information.



CAUTION: Hot Surface Warning



Do Not Touch: Touching some parts of the instrument without protection or proper tools could result in damage to the part(s) and/or the instrument.



Technician Symbol: All operations marked with this symbol are to be performed by qualified maintenance personnel only.



Electrical Ground: This symbol inside the instrument marks the central safety grounding point for the instrument.

CAUTION



This instrument should only be used for the purpose and in the manner described in this manual. If you use this instrument in a manner other than that for which it was intended, unpredictable behavior could ensue with possible hazardous consequences.

NEVER use any gas analyzer to sample combustible gas(es)!

Note

For Technical Assistance regarding the use and maintenance of this instrument or any other Teledyne API product, contact Teledyne API's Customer Service Department:

Phone: 800-324-5190

Email: api-customerservice@teledyne.com

or by accessing various service options on our website at

<http://www.teledyne-api.com/>.

CONSIGNES DE SÉCURITÉ

Des consignes de sécurité importantes sont fournies tout au long du présent manuel dans le but d'éviter des blessures corporelles ou d'endommager les instruments. Itée par un pictogramme d'alerte de sécurité; ces pictogrammes se retrouvent dans ce manuel et à l'intérieur des instruments. Les symboles correspondent aux consignes suivantes :



AVERTISSEMENT : Risque de choc électrique



DANGER : Oxydant puissant



AVERTISSEMENT GÉNÉRAL / MISE EN GARDE : Lire la consigne complémentaire pour des renseignements spécifiques



MISE EN GARDE : Surface chaude



Ne pas toucher : Toucher à certaines parties de l'instrument sans protection ou sans les outils appropriés pourrait entraîner des dommages aux pièces ou à l'instrument.



Pictogramme « technicien » : Toutes les opérations portant ce symbole doivent être effectuées uniquement par du personnel de maintenance qualifié.



Mise à la terre : Ce symbole à l'intérieur de l'instrument détermine le point central de la mise à la terre sécuritaire de l'instrument.

MISE EN GARDE



Cet instrument doit être utilisé aux fins décrites et de la manière décrite dans ce manuel. Si vous utilisez cet instrument d'une autre manière que celle pour laquelle il a été prévu, l'instrument pourrait se comporter de façon imprévisible et entraîner des conséquences dangereuses.

NE JAMAIS utiliser un analyseur de gaz pour échantillonner des gaz combustibles!

ABOUT THIS MANUAL

This addendum is to be used in conjunction with the T200 Operation Manual, PN 06858.

REVISION HISTORY

This section provides information regarding changes to this manual.

2011 December 07, Model T265 Addendum,		
Rev	DCN	Description of Changes
B	6324	Specs update: Zero Noise, LDL, Zero and Span Drifts
2011 November 08, T265 Addendum, PN07337A, DCN6120, Initial Release		

This page intentionally left blank.

TABLE OF CONTENTS

IMPORTANT SAFETY INFORMATION	I
ABOUT THIS MANUAL.....	III
REVISION HISTORY	III
TABLE OF CONTENTS.....	V
1. INTRODUCTION.....	7
1.1 OVERVIEW.....	7
2. SPECIFICATIONS, APPROVALS, & CERTIFICATIONS.....	9
2.1 EPA DESIGNATION	11
2.2 COMPLIANCE STATEMENTS	11
2.2.1 <i>Safety</i>	11
2.2.2 <i>EMC</i>	11
2.3 WARRANTY	11
3. GETTING STARTED.....	13
3.1 UNPACKING	13
3.2 INSTRUMENT LAYOUT	15
3.2.1 <i>Front Panel</i>	15
3.2.2 <i>Rear Panel</i>	16
3.2.3 <i>Internal Chassis Layout</i>	17
3.3 CONNECTIONS AND SETUP	18
3.3.1 <i>Electrical and Pneumatic Connections</i>	18
3.4 STARTUP, FUNCTIONAL CHECKS, AND INITIAL CALIBRATION	20
3.4.1 <i>Startup</i>	20
3.4.2 <i>Initial Calibration</i>	20
4. MAINTENANCE	23
4.1 MAINTENANCE SCHEDULE.....	23
4.2 MAINTENANCE ITEMS SPECIFIC TO THE MODEL T265	23
5. PRINCIPLES OF OPERATION	25

LIST OF FIGURES

FIGURE 3-1. FRONT PANEL	15
FIGURE 3-2. REAR PANEL	16
FIGURE 3-3. INTERNAL CHASSIS LAYOUT	17
FIGURE 3-4. T265 PNEUMATICS, BASIC CONFIGURATION	19

LIST OF TABLES

TABLE 2-1. MODEL T265 SPECIFICATIONS	10
--	----

This page intentionally left blank.

1. INTRODUCTION

This section presents a brief overview of the Model T265; supplemental information may be found in the Model T200 Operation Manual.

1.1 OVERVIEW

The Model T265 is a close derivative of the Model T200 Chemiluminescence NO_x Analyzer. This addendum provides an overview of the instrument with details of the features and functions that are specific to the Model T265; it is intended as a supplement to the Model T200 operation manual (Teledyne API part number 06858). Note: it is imperative that before placing the analyzer into service, users familiarize themselves with the Model T200 manual, which describes in detail specific functionality common to both products, such as hardware adjustment during calibration, initializing communications with the product and trouble-shooting approaches.

This page intentionally left blank.

2. SPECIFICATIONS, APPROVALS, & CERTIFICATIONS

Table 2-1 presents the specifications for the Model T265 analyzer. This is followed by EPA and Safety and Emissions Compliance information.

Table 2-1. Model T265 Specifications

PARAMETER	SPECIFICATION
Ranges	0-100 ppb to 0-2,000 ppb full scale, user selectable.
Measurement Mode	Single Range or AutoRange
Measurement Units	ppb, ppm, $\mu\text{g}/\text{m}^3$ mg/m^3
Zero Noise ¹	<0.15 ppb (RMS)
Span Noise ¹	<0.5% of reading (RMS) above 100 ppb
Lower Detectable Limit	<0.3 ppb
Zero Drift (24 hours)	<0.5 ppb
Span Drift (24 hours)	<0.5% of full scale
Linearity	<1% of full scale
Precision	<0.5% of reading
Lag Time ¹	<10 sec
Rise/Fall Time ¹	<20 sec to 95%
Sample Flow Rate	500 $\text{cm}^3/\text{min} \pm 10\%$
Reagent Gas	NO at 10,000 ppm $\pm 10\%$
Reagent Flow	5 ± 2 cm^3/min
Environmental	Installation Category (Over-voltage Category) II Pollution Degree 2
Temperature Range	5 – 40° C (with EPA equivalency)
Humidity Range	10-90% RH non-condensing
Dimensions H x W x D	7" x 17" x 23.5" (18 cm x 43 cm x 61 cm)
Weight, Analyzer	40 lbs (18 kg) (with internal pump)
AC Power	100 V – 120 V, 60Hz (3.0 A) 220 V – 240 V, 50 Hz (2.5 A)
Analog Output Ranges	All Outputs: 100 mV, 1 V, 5 V, 10 V Two concentration outputs convertible to 4-20 mA isolated current loop (option) All Ranges with 5% Under/Over Range
Analog Output Resolution	1 part in 4096 of selected full scale voltage
Standard I/O	1 Ethernet: 10/100Base-T 2 RS-232 (300 – 115,200 baud) 2 USB device ports 8 opto-isolated digital status outputs 6 opto-isolated digital control inputs 4 analog outputs
Optional I/O	1 USB com port 1 RS485 8 analog inputs (0-10V, 12-bit) 4 digital alarm outputs Multidrop RS232 3 4-20mA current outputs
¹ As defined by the US EPA	

2.1 EPA DESIGNATION

Teledyne API's Model T265 Chemiluminescence Ozone Analyzer received EPA approval for Designation EQOA-0611-199. The designation will be considered valid when operated under the following conditions:

- on any full scale range between 0-100 ppb and 0-1000 ppb
- with any range mode (Single, Dual, or AutoRange)
- at any ambient temperature in the range of 5°C to 40°C
- with a TFE filter in the sample air inlet
- with a sample flow rate of 500 ± 50 cm³/min (sea level)
- with the dilution factor set to 1
- with Temp/Press compensation ON
- in accordance with the appropriate associated instrument manuals
- with or without any of the following options:
 - Internal or external sample pump
 - Sample/Cal valve option
 - Rack mount with or without slides
 - Analog input option
 - 4-20 mA isolated current loop output

2.2 APPROVALS AND CERTIFICATIONS

The Teledyne - API Model T265 analyzer was tested and certified for Safety and Electromagnetic Compatibility (EMC). This section presents the compliance statements for those requirements and directives.

2.2.1 Safety

IEC 61010-1:2001, Safety requirements for electrical equipment for measurement, control, and laboratory use.

CE: 2006/95/EC, Low-Voltage Directive

North American:

cNEMKO (Canada): CAN/CSA-C22.2 No. 61010-1-04

NEMKO-CCL (US): UL No. 61010-1 (2nd Edition)

2.2.2 EMC

EN 61326-1 (IEC 61326-1), Class A Emissions/Industrial Immunity

EN 55011 (CISPR 11), Group 1, Class A Emissions

FCC 47 CFR Part 15B, Class A Emissions

CE: 2004/108/EC, Electromagnetic Compatibility Directive

2.3 WARRANTY

Refer to the Model T200 operation manual regarding the Warranty policy for the Model T265.

This page intentionally left blank.

3. GETTING STARTED

This section addresses the procedures for unpacking the instrument and inspecting for damage, and introduces the instrument layout, then presents the procedures for getting started: making electrical and pneumatic connections, and conducting an initial calibration check. Please see the Model T200 Operation Manual for more information.

3.1 UNPACKING



CAUTION – GENERAL SAFETY HAZARD

To avoid personal injury, always use two persons to lift and carry the Model T265.

ATTENTION

COULD DAMAGE INSTRUMENT AND VOID WARRANTY

Printed Circuit Assemblies (PCAs) are sensitive to electro-static discharges too small to be felt by the human nervous system. Failure to use ESD protection when working with electronic assemblies will void the instrument warranty

See *A Primer on Electro-Static Discharge* in the accompanying Model T200 manual for more information on preventing ESD damage.



CAUTION - ELECTRICAL SHOCK HAZARD

Never disconnect PCAs, wiring harnesses or electronic subassemblies while analyzer is under power.

**CAUTION**

Remove dust plugs from pneumatic fittings on the rear panel of the analyzer, prior to applying power to the analyzer.

Note

It is recommended that you store shipping containers/materials for future use if/when the instrument should be returned to the factory for repair and/or calibration service. See Warranty section in this manual and shipping procedures on our Website at <http://www.teledyne-api.com> under Customer Support > Return Authorization.

1. First, verify that there is no apparent external shipping damage. If damage has occurred, please advise the shipper first, then Teledyne-API. Save the packaging for shipper's examination.
2. Included with your analyzer is a printed record of the final performance characterization performed on your instrument at the factory. This record, titled Final Test and Validation Data Sheet (P/N 06627) is an important quality assurance and calibration record for this instrument. It should be placed in the quality records file for this instrument.
3. Carefully remove the top cover of the analyzer and check for internal shipping damage.
 - Remove the set screw located in the top, center of the front panel.
 - Remove the two screws fastening the top cover to the unit (one per side towards the rear).
 - Slide the cover backward until it clears the analyzer's front bezel.
 - Lift the cover straight up.
 - Check for internal shipping damage, and generally inspect the interior of the instrument to make sure all circuit boards and other components are in good shape and properly seated.
4. Reinstall the cover and screws, once the inspection is complete.
5. Check the voltage and frequency label on the serial number tag on the rear panel. Compare that to your local power before plugging the instrument into an outlet.

3.2 INSTRUMENT LAYOUT

Instrument layout includes front panel and display, rear panel connectors, and internal chassis layout.

3.2.1 Front Panel

Figure 3-1 illustrates the front panel of the Model T265 analyzer.

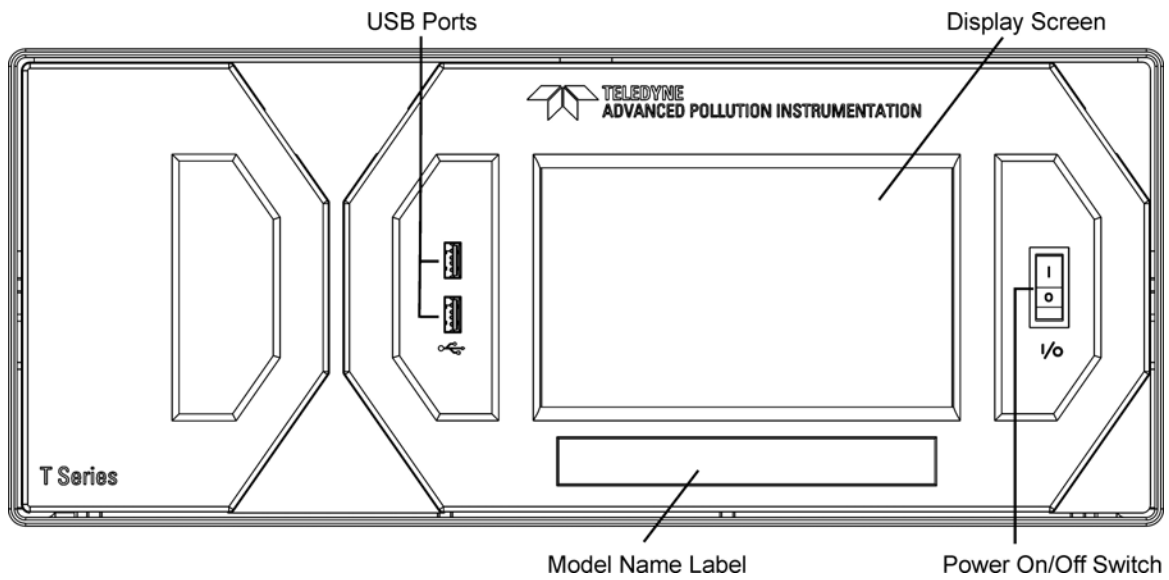

Figure 3-1. Front Panel

3.2.2 Rear Panel

Figure 3-2 illustrates the layout of the Model T265 analyzer's rear panel.

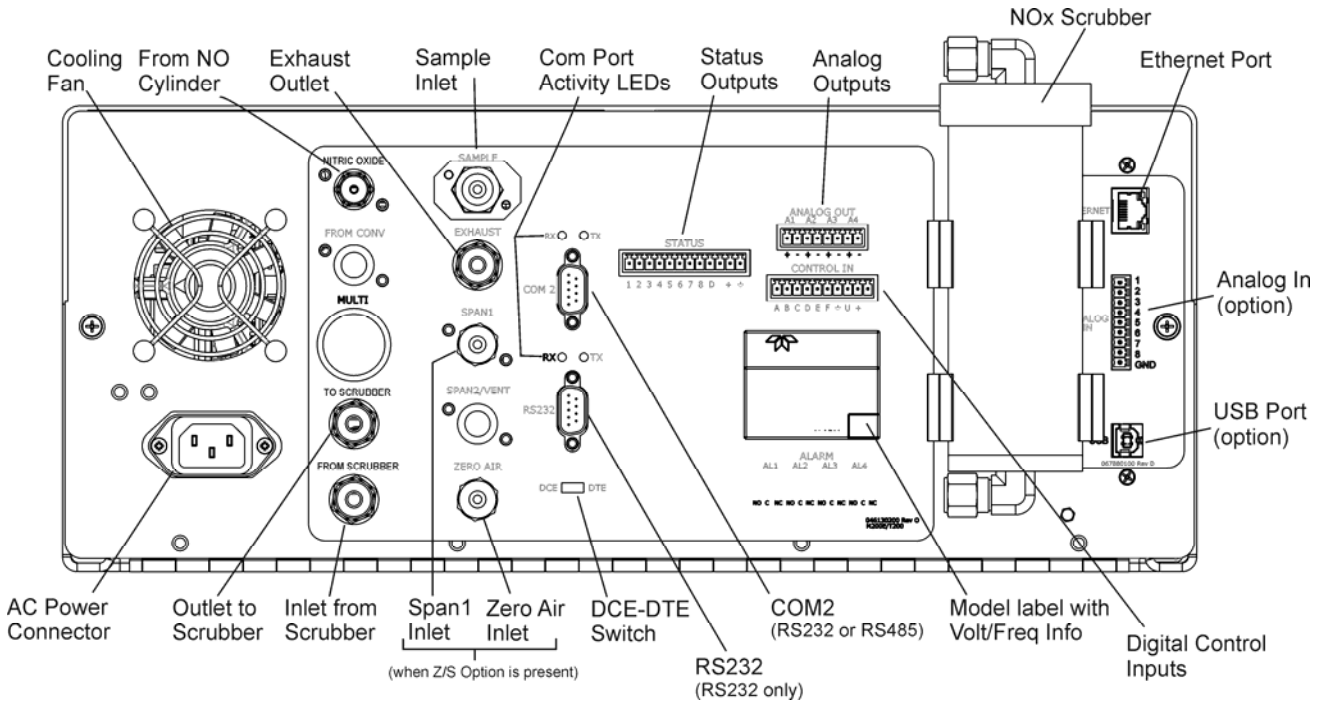

Figure 3-2. Rear Panel

3.2.3 Internal Chassis Layout

Figure 3-3 illustrates the location of the internal chassis components.

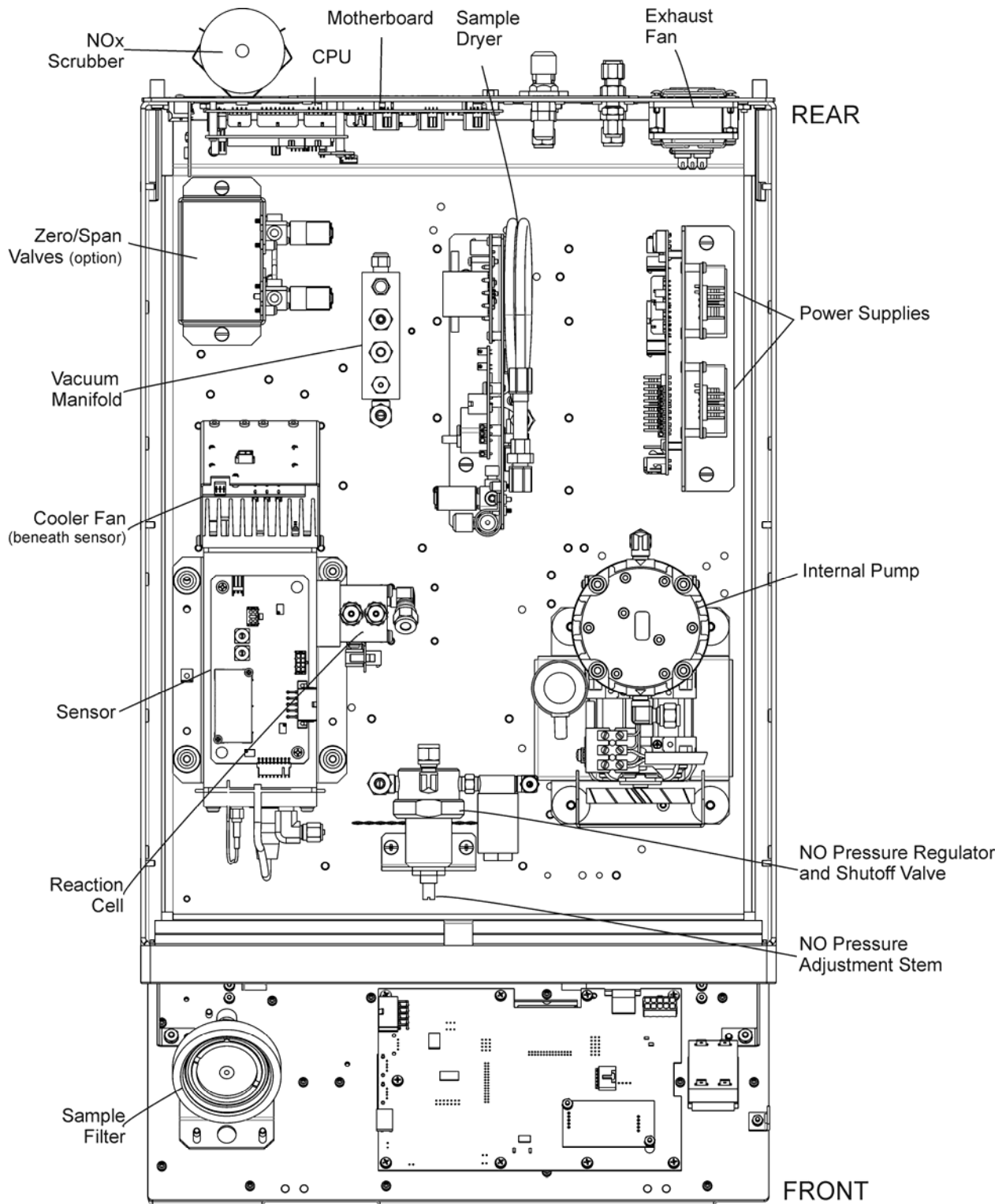

Figure 3-3. Internal Chassis Layout

3.3 CONNECTIONS AND SETUP

This section presents connection information for setting up the instrument to operate.

3.3.1 Electrical and Pneumatic Connections

1. Refer to Figure 3-2 for the rear panel electrical and pneumatic connectors.
2. Mount the NO_x scrubber with base down (arrow labeled “FLOW” pointing down) onto the rear panel.
3. Connect tubing from NO_x scrubber base fitting to rear panel fitting labeled “FROM SCRUBBER”.
4. Connect tubing from NO_x scrubber top fitting to rear panel fitting labeled “TO SCRUBBER”.
5. Vent the EXHAUST port to atmospheric pressure and out of the room, because of its nitric oxide content.



CAUTION

GENERAL SAFETY HAZARD

Analyzer Exhaust Contains Nitric Oxide Gas.

Vent pump exhaust to a well-ventilated area at atmospheric pressure. Obtain a Material Safety Data Sheet (MSDS) for this material. Read and rigorously follow the safety guidelines described there.

6. Attach the sample inlet line to the sample inlet port. The pressure of the sample gas at the inlet port should be at ambient pressure and constant.
7. Using 1/8” stainless steel tubing, attach a cylinder with 10,000 ppm \pm 10% of nitric oxide (NO) in nitrogen (N₂), with an appropriate pressure regulator, to the 1/8” stainless steel port (labeled NITRIC OXIDE) on the rear panel as shown in Figure 3-2. Note: The NO cylinder’s pressure regulator should be set to deliver gas at 20 PSIG \pm 5 PSIG.
8. Attach a strip chart recorder and/or data-logger to the appropriate analog output connections on the rear panel. See section on analog output connections in the Model T200 manual for connector pin-out definitions.
9. Connect the power cord to the correct line voltage.



WARNING

Lethal voltages present inside the analyzer’s case.

- Do not operate with cover off during normal operation.
- Before operation, check for correct input voltage and frequency.
- Do not operate without proper chassis grounding.
- Do not defeat the ground wire on power plug.
- Turn off analyzer power before disconnecting electrical subassemblies.

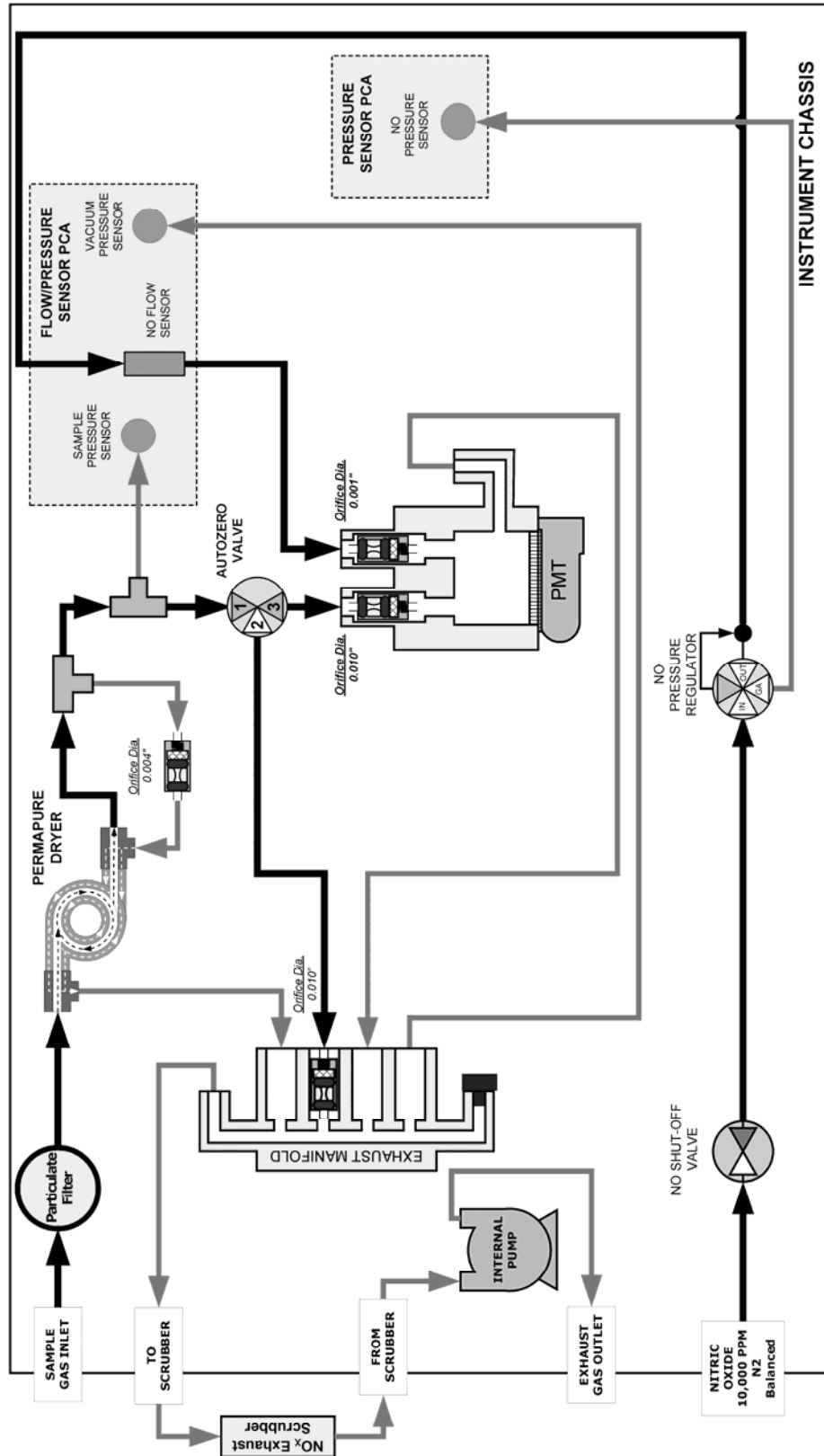

Figure 3-4. T265 Pneumatics, Basic Configuration

STARTUP, FUNCTIONAL CHECKS, AND INITIAL CALIBRATION

3.4.1 Startup

1. Turn on the instrument by pressing the on/off rocker switch on the front panel. The display should immediately light, showing the computer's memory configuration, then the instrument type - Model T265. A diagram of the software menu trees can be found in Appendix A of this addendum.
2. Thirty minutes after power-up an internal solenoid valve will open allowing Nitric Oxide gas to flow. Check the Nitric Oxide flow "NO FLOW" test function (TEST button, <TST TST> buttons) on the front panel to verify that the flow is $5 \text{ cm}^3/\text{min} \pm 2. \text{ cm}^3/\text{min}$.
 - If the flow is out of this range, check the Nitric Oxide pressure "NO PRESS" test function on the front panel display, to verify that the pressure is set to 5 PSIG +/- 1 PSIG.
 - If the pressure is out of this range, check that the cylinder regulator is set to 20 PSIG, then drop the front panel and use a flat head screw driver to turn the NO Pressure Adjustment Stem (Figure 3-3) to adjust the NO pressure regulator: clockwise to increase; counter-clockwise to decrease.

Note

The NO pressure sets the flow; therefore, the "NO PRESS" test function is of greater importance when setting up the analyzer. The "NO FLOW" test function is only provided to indicate the presence of gas flow.

- The Model T265 analyzer requires about one hour for all internal components to heat to operating temperature.

IMPORTANT

IMPACT ON READINGS OR DATA

It is recommended that the analyzer operate for about four (4) hours before calibration and the collection of reliable readings.

3. When the instrument is warmed up, check the TEST functions. All of the readings should compare closely with those in Appendix C of this addendum.
4. After checking the TEST functions, calibrate the instrument as presented sequentially in Parts 1 through 3 in Section 3.4.2, which follows.

3.4.2 Initial Calibration

The initial calibration is accomplished in three parts:

- Setting the range and inputting the expected ozone span gas concentration
- Performing a zero/span calibration
- Running a calibration quality check

Part 1 - Set the range, then enter the expected ozone span gas concentration:

Step	Action	Comment
1.	Press CAL>CONC	This menu sequence causes the Model T265 to prompt for the expected span concentration. Enter the span value by pressing the button for each digit until the expected value is set.
2.	Press ENTR	ENTR stores the expected span value. The internal formula is adjusted to compute this number when span gas concentration is input into the instrument.
5.	Press EXIT	Returns instrument to SAMPLE mode.
6.	Press SETUP>RNGE> MODE>SNGL	If necessary, you may want to change the Range Mode. Choices are either Single or AutoRange. Normally the instrument is shipped in Single Range Mode.
7.	Press SETUP>RNGE> SET	After the mode is set, you may want to set the maximum Range value. The instrument is shipped with the Range set at 500 ppb. This setting affects only your analog outputs, not the RS-232 output.

Part 2 - Calibrate the instrument: Zero/Span Calibration Procedure

Step	Action	Comment
1.	Input zero gas	Allow zero gas to flow passed the sample port on the rear of the instrument.
2.	Press CAL	The Model T265 enters the calibrate mode from sample mode.
3.	Wait 30 min	Wait for the reading to stabilize at the zero value. If you wait less than 10 minutes the final zero value may drift. You may want to watch the stability "O ₃ STB" test function (moving standard deviation) for its minimum value.
4.	Press ZERO	The ZERO button will be displayed once the concentration approaches zero.
5.	Press ENTR	Pressing ENTR zeroes the instrument and adjusts both offset and slope so that Zero concentration is displayed.

Step	Action	Comment
6.	Press EXIT, input Span gas	The Model T265 returns to the CAL menu. Now allow span gas to flow passed the instrument.
7.	Wait 30 min	Wait for the O ₃ reading to stabilize at the span value (watch O ₃ STB).
8.	Press SPAN	The SPAN button should be displayed once the concentration approaches the span value. In certain circumstances at low span concentrations both the ZERO and SPAN buttons will appear. Do not press ZERO again when running span gas!
9.	Press ENTR	Pressing ENTR to span the instrument actually changes the equations so that the concentration displayed is the same as the expected span concentration you entered above, thus spanning the instrument.
10.	Press EXIT	Pressing EXIT returns the instrument to SAMPLE mode.

IMPORTANT**IMPACT ON READINGS OR DATA**

Over time PMTs lose sensitivity, which is reflected by an increase in the O₃ slope test function during ongoing calibrations. If the slope falls outside the range of 0.7 to 1.3, a hardware adjustment to the PMT gain is required. The process involves the adjustment of both a high and low gain potentiometer, located on the preamp printed circuit board, while noting the "NORM PMT" test function value, for a particular concentration of Ozone span gas. Typically, the high voltage to the PMT is adjusted, such that, the "NORM PMT" is twice the measured O₃ concentration. **See *PMT Sensor Hardware Calibration in the Model T200 manual's Troubleshooting & Service section for detailed procedures.***

Step 3 - Review Quality of calibration: Calibration Quality Check Procedure

Step	Action	Comment
1.	Scroll the TEST function menu until the O ₃ SLOPE is displayed.	The SLOPE value for O ₃ should be 1.0 ± 0.3 . If the SLOPE value is in the acceptable range the instrument will perform optimally.
2.	Scroll the TEST function menu until the O ₃ OFFS is displayed.	The Model T265 will display the offset parameter "O ₃ OFF" for the O ₃ equation. This number should be near zero. A value of ± 10 indicates calibration in the optimal range.

The Model T265 is now ready to measure sample gas.

4. MAINTENANCE

4.1 MAINTENANCE SCHEDULE



CAUTION

The operations outlined in this section are to be performed by qualified maintenance personnel only.

Please refer to the *Instrument Maintenance* section of the Model T200 manual for maintenance items and their interval schedules.

Exceptions:

- “Ozone cleanser” does not apply.
- The reaction cell window (optical filter) may not need to be cleaned annually, but rather on an “as needed” basis.

4.2 MAINTENANCE ITEMS SPECIFIC TO THE MODEL T265

Annually replace the charcoal in the NO_x scrubber, attached to the rear of the analyzer; Kit 005960000.

This page intentionally left blank.

5. PRINCIPLES OF OPERATION

The Teledyne API Model T265 analyzer is designed to measure the concentration of ozone using the chemiluminescence reaction below. The signal comes from the light emitted by the gas phase reaction of nitric oxide (NO) and ozone (O₃) as follows:

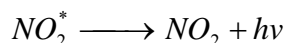
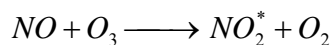

The reaction of ozone with NO results in electronically excited NO₂^{*} molecules as shown in the first equation. The excited NO₂^{*} molecules release their excess energy by emitting a photon *hv* and dropping to a lower energy level as shown in the second equation. It has been shown that the number of emitted photons is directly proportional to the O₃ concentration in the sample stream.

Calibration of the instrument is performed in software and usually does not require physical adjustments to the instrument. During calibration, the microprocessor measures the photo multiplier tube (PMT) signal when gases with known amounts of O₃ are supplied, and stores these results in memory. The microprocessor uses these calibration values, along with the signal from the sample gas, the pressure readings for both the reaction cell and sample gas and box temperature in order to calculate a final concentration.

The product requires a cylinder of NO balanced in N₂, which acts as the reagent gas. Both the electronic and pneumatic platforms are built using the current T series hardware. An additional precision regulator is added to keep the NO pressure constant, prior to the reaction cell. The internal pump draws sample through the sample dryer, removing ambient moisture, into the reaction cell. Periodically, an AutoZero valve switches the sample stream to the vacuum manifold, allowing the reaction cell to be evacuated and the analyzer to read zero background. The AutoZero readings are subtracted from the concentration readings, which improves zero baseline stability.

The analyzer uses two temperature-controlled critical orifices to deliver sample O₃ and reagent NO into the reaction cell. See diagram of the pneumatic design in Figure 3-4.

This page intentionally left blank.

APPENDIX A: Models T265 and 265E Menu Trees

The following menu trees in this appendix show the structure of the Sample menu and the Setup submenu. For additional details refer to Appendix A of the Model T200 operation manual.

This page intentionally left blank.

APPENDIX A-1: Software Menu Trees: Sample Menu

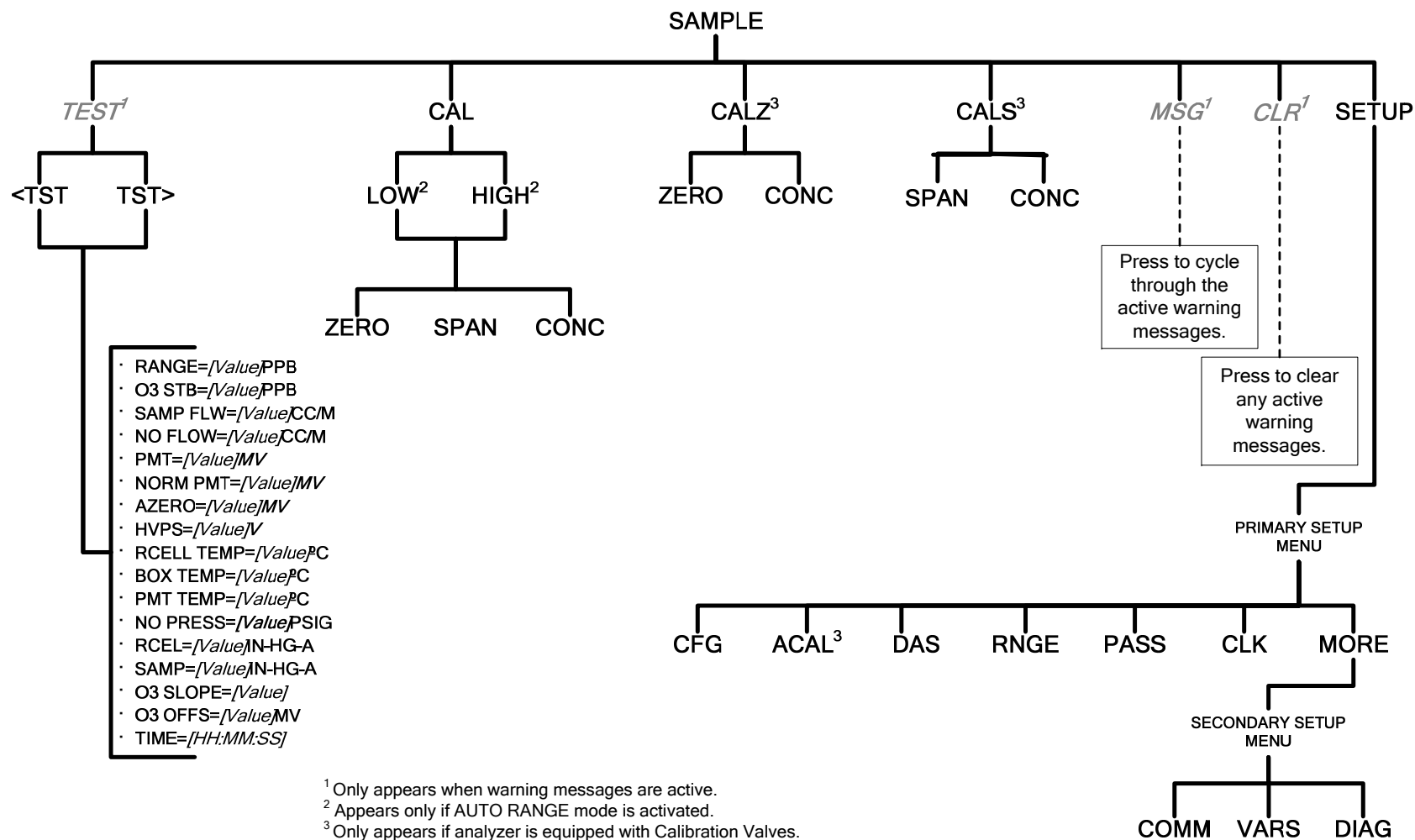

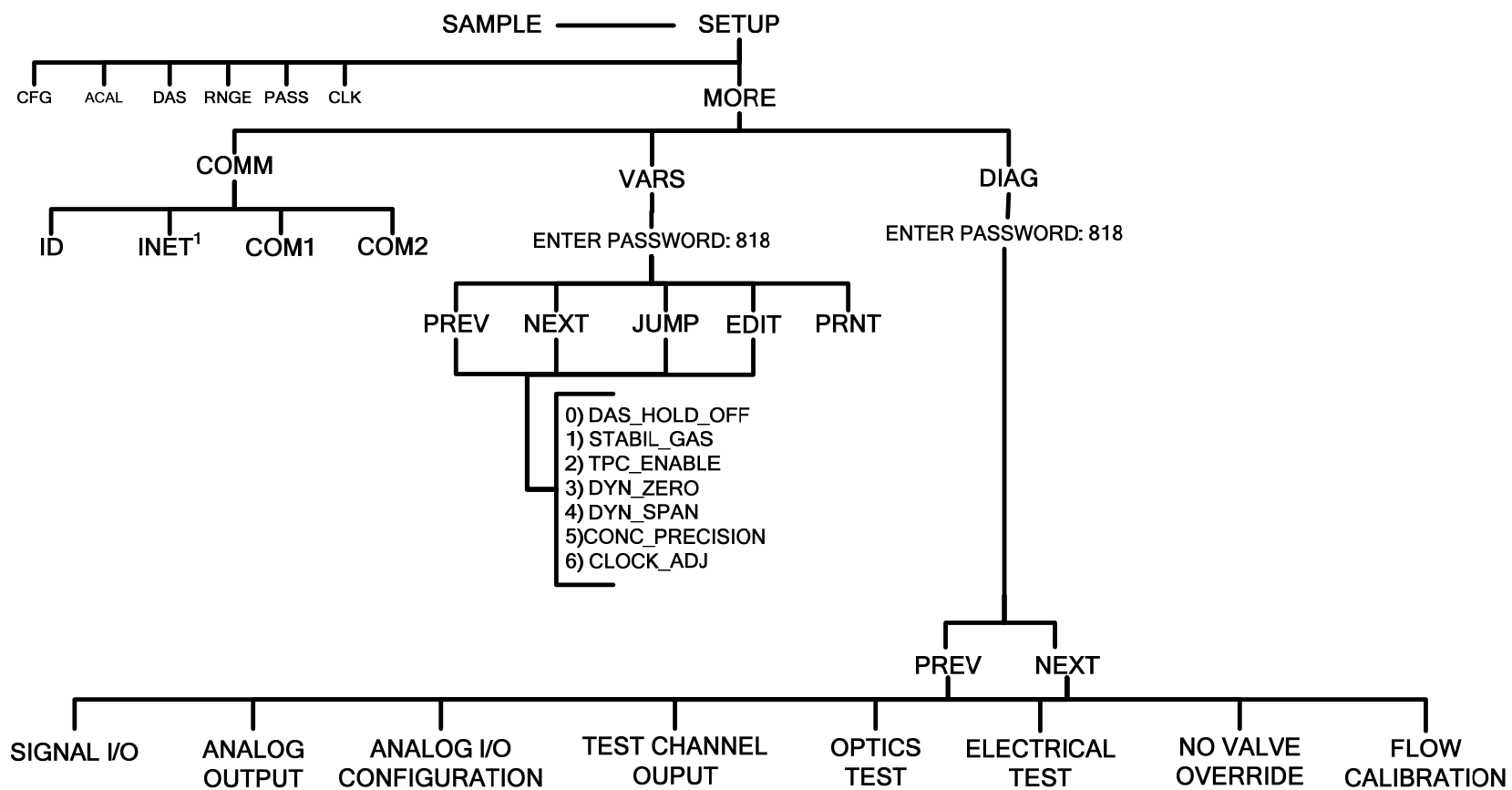

¹ E-Series models: Only appears if optional Ethernet PCA is installed.
 NOTE: When Ethernet PCA is present in E-Series models, COM2 submenu disappears.

For all other menus, refer to main manual for your model (T265: T200 or Model 265E: M200E).

APPENDIX B - Spare Parts

Note Use of replacement parts other than those supplied by Teledyne Advanced Pollution Instrumentation (TAPI) may result in non-compliance with European standard EN 61010-1.

Note Due to the dynamic nature of part numbers, please refer to the TAPI Website at <http://www.teledyne-api.com> or call Customer Service at 800-324-5190 for more recent updates to part numbers.

This page intentionally left blank.

T265 Spare Parts List

(Reference: 07388 06/01/2011, 15:53)

PARTNUMBER	DESCRIPTION
000940600	CD, ORIFICE, .010 BROWN
000941800	CD, ORIFICE, .001, RED/BLK
001330000	SLEEVE, 303 SS (UNPLATED) (KB)
002160000	ASSY, SCRUBBER, M200A/AH/M100AH, PUMPACK
002270100	AKIT, GASKETS, WINDOW, (12 GASKETS = 1)
002730000	CD, FILTER, 665NM (KB)
005960000	AKIT, EXP, 6LBS ACT CHARCOAL (2 BT=1)
008140000	DRYER ASSEMBLY (KB)
008830000	COLD BLOCK (KB)
009690200	AKIT, TFE FLTR ELEM (FL19,100=1) 47mm
009690300	AKIT, TFE FLTR ELEM (FL19, 30=1) 47mm
009810300	ASSY, PUMP PK, 115V/60HZ w/FL34/NO/SO
009810600	ASSY, PUMP PACK, 100V/60HZ w/FL34
009811000	ASSY, PUMP, NOX, 220-240V/50-60HZ FL34
011630000	HVPS INSULATOR GASKET (KB)
013140000	ASSY, COOLER FAN (NOX/SOX)
014080200	ASSY, HVPS, NOX
014610000	KIT, REPLACEMENT COOLER ASSY
016290000	WINDOW, SAMPLE FILTER, 47MM (KB)
016301100	ASSY, SAMPLE FILTER, 47MM, ANG BKT, 1UM
022890000	ASSY, PMT, LOW DARK CURR/HI GAIN, M200AU
037860000	ORING, TEFLON, RETAINING RING, 47MM (KB)
040010000	ASSY, FAN REAR PANEL
040030800	PCA, PRESS SENSORS (2X), FLOW, (NOX)
040400000	ASSY, HEATERS/THERMAL SWITCH, RX CELL
040900000	ORIFICE HOLDER, REACTION CELL (KB)
041800500	PCA, PMT PREAMP, VR
041920000	ASSY, THERMISTOR
043170000	MANIFOLD, RCELL, (KB) *
045230100	PCA, RELAY CARD(KB)
045500300	ASSY, ORIFICE HOLDER, 10 MIL, (NOX)
045500800	ASSY, ORIFICE HOLDER, 1 MIL
046030000	AKIT, CH-43, 3 REFILLS
047150200	AKIT, EXPENDABLES, M265E
049310100	PCA,TEC DRIVER,PMT,(KB)
051990000	ASSY, SCRUBBER, INLINE EXHAUST, DISPOS
055740000	ASSY, PUMP, NOx PUMP PACK, 115V/60HZ
055740100	ASSY, PUMP, NOx PUMP PACK, 220V/60HZ
055740200	ASSY, PUMP, NOx PUMP PACK, 220V/50HZ
058021100	PCA, MOTHERBD, GEN 5-ICOP
059430000	ASSY, VALVE, VA59 w/o DIODE, 5" LEADS *
059430100	ASSY, VALVE, VA59 w/o DIODE, 9" LEADS *
059940000	OPTION, SAMPLE GAS CONDITIONER, NOX*
064540000	ASSY, PUMP NOX INTERNAL, 115V/60HZ
064540100	ASSY, PUMP NOX INTERNAL, 230V/60HZ
064540200	ASSY, PUMP NOX INTERNAL, 230V/50HZ
066100000	REGULATOR, PRESSURE, 0-10 PSIG
066140000	SENSOR M265E,03 CHEMI ANALYZER
066210000	ASSY, O3 REACTION CELL 265E

T265 Spare Parts List

(Reference: 07388 06/01/2011, 15:53)

PARTNUMBER	DESCRIPTION
066220000	ASSY, VACUUM MANIFOLD, M265E
066970000	PCA, INTRF. LCD TOUCH SCRNR, F/P
067240000	CPU, PC-104, VSX-6154E, ICOP *(KB)
067300000	PCA, AUX-I/O BD, ETHERNET, ANALOG & USB
067300100	PCA, AUX-I/O BOARD, ETHERNET
067300200	PCA, AUX-I/O BOARD, ETHERNET & USB
067900000	LCD MODULE, W/TOUCHSCREEN(KB)
068810000	PCA, LVDS TRANSMITTER BOARD
068870000	ASSY, VALVE, 265E REGULATOR
069500000	PCA, SERIAL & VIDEO INTERFACE BOARD
072150000	ASSY. TOUCHSCREEN CONTROL MODULE
073370000	MANUAL, ADDENDUM, T265
CN0000073	POWER ENTRY, 120/60 (KB)
CN0000458	PLUG, 12, MC 1.5/12-ST-3.81 (KB)
CN0000520	PLUG, 10, MC 1.5/10-ST-3.81 (KB)
FL0000001	FILTER, SS (KB)
FL0000003	FILTER, DFU (KB)
FL0000019	ELEMENT, FILTER, TFE, 47MM, (1UM) *(KB)
FM0000004	FLOWMETER (KB)
FT0000010	CONNECTOR-ORING, SS, 1/8" (HK)
HW0000005	FOOT
HW0000020	SPRING
HW0000030	ISOLATOR
HW0000031	FERRULE, SHOCKMOUNT
HW0000093	SPRING
HW0000099	STANDOFF, #6-32X.5, HEX SS M/F
HW0000101	ISOLATOR
HW0000453	SUPPORT, CIRCUIT BD, 3/16" ICOP
HW0000685	LATCH, MAGNETIC, FRONT PANEL
KIT000051	AKIT, REBUILD, RX CELL AMBIENT
KIT000095	AKIT, REPLACEMENT COOLER
KIT000207	KIT, RELAY RETROFIT
KIT000208	KIT, M200E RELAY RETRO, GND'ED HICON
KIT000219	AKIT, 4-20MA CURRENT OUTPUT
KIT000231	KIT, RETROFIT, Z/S VALVE
KIT000240	KIT, M200E RELAY RETRO, ISOLATED HICON
KIT000249	KIT, M200E RELAY BOARD RETROFIT, 220V
KIT000253	ASSY & TEST, SPARE PS37
KIT000254	ASSY & TEST, SPARE PS38
OR0000001	ORING, 2-006VT *(KB)
OR0000002	ORING, 2-023V
OR0000025	ORING, 2-133V
OR0000027	ORING, 2-042V
OR0000034	ORING, 2-011V FT10
OR0000039	ORING, 2-012V
OR0000044	ORING, 2-125V
OR0000086	ORING, 2-006, CV-75 COMPOUND(KB)
OR0000094	ORING, 2-228V, 50 DURO VITON(KB)
PU0000005	PUMP, THOMAS 607, 115V/60HZ (KB)

T265 Spare Parts List

(Reference: 07388 06/01/2011, 15:53)

PARTNUMBER	DESCRIPTION
PU0000011	REBUILD KIT, THOMAS 607(KB)
PU0000052	PUMP, THOMAS 688, 220/240V 50HZ/60HZ
PU0000054	PUMP, THOMAS 688, 100V, 50/60HZ
PU0000083	KIT, REBUILD, PU80, PU81, PU82
RL0000015	RELAY, DPDT, (KB)
SW0000025	SWITCH, POWER, CIRC BREAK, VDE/CE *(KB)
SW0000059	PRESSURE SENSOR, 0-15 PSIA, ALL SEN
WR0000008	POWER CORD, 10A(KB)

This page intentionally left blank.

Appendix C
Warranty/Repair Questionnaire
M265E and T265
(P/N 074990000 Rev A, DCN# 6167)



CUSTOMER: _____ PHONE: _____

CONTACT NAME: _____ FAX NO. _____

SITE ADDRESS: _____

MODEL SERIAL NO.: _____ FIRMWARE REVISION: _____

1. ARE THERE ANY FAILURE MESSAGES? _____

PLEASE COMPLETE THE FOLLOWING TABLE: (NOTE: *DEPENDING ON OPTIONS INSTALLED, NOT ALL TEST PARAMETERS SHOWN BELOW WILL BE AVAILABLE IN YOUR INSTRUMENT*)

*IF OPTION IS INSTALLED

PARAMETER	RECORDED VALUE	ACCEPTABLE VALUE
RANGE	PPB/PPM	100 PPB TO 2000 PPB
O3 STAB	PPB/PPM	< 0.3 PPB (RMS) WITH ZERO AIR
SAMPLE FLOW	CM ³	500 ± 50
NO FLOW	CM ³	5 ± 2
PMT SIGNAL WITH ZERO AIR	MV	-20 TO 150
PMT SIGNAL AT SPAN GAS CONC	MV PPB	0-5000MV 0-20000 PPB
NORM PMT SIGNAL AT SPAN GAS CONC	MV PPB	0-5000MV 0-20000PPB
AZERO	MV	-20 TO 150
HVPS	V	400 – 900
RCELL TEMP	°C	50 ± 1
BOX TEMP	°C	AMBIENT + 3 -7°C
PMT TEMP	°C	7 ± 2°C
RCEL PRESS	IN-HG-A	2-10 (constant)
SAMP PRESS	IN-HG-A	AMBIENT - 1 ± 1
NO PRESS	IN PSIG	5 ± 0.2
O3 SLOPE		1.0 ± 0.3
O3 OFFSET		-20 TO 150
ETEST	PMT MV	2000 ± 1000
OTEST	PMT MV	2000 ± 1000
Values are in the Signal I/O		
REF_4096_MV	MV	4096mv ±2mv and Must be Stable
REF_GND	MV	0± 0.5 and Must be Stable

TELEDYNE API CUSTOMER SERVICE
EMAIL: api-customerservice@teledyne.com
PHONE: (858) 657-9800 TOLL FREE: (800) 324-5190 FAX: (858) 657-9816

Appendix C
Warranty/Repair Questionnaire
M265E and T265
(P/N 074990000 Rev A, DCN# 6167)



2. WHAT ARE THE RCELL & SAMPLE PRESSURES WITH THE SAMPLE INLET ON REAR OF MACHINE CAPPED?

RCELL PRESS - _____ IN-HG-A SAMPLE PRESSURE - _____ IN-HG-A

3. WHAT ARE THE FAILURE SYMPTOMS? _____

4. WHAT TEST(S) HAVE YOU DONE TRYING TO SOLVE THE PROBLEM? _____

5. IF POSSIBLE, PLEASE INCLUDE A PORTION OF A STRIP CHART PERTAINING TO THE PROBLEM. CIRCLE PERTINENT DATA.

THANK YOU FOR PROVIDING THIS INFORMATION. YOUR ASSISTANCE ENABLES TELEDYNE API TO RESPOND FASTER TO THE PROBLEM THAT YOU ARE ENCOUNTERING.

TELEDYNE API CUSTOMER SERVICE
EMAIL: api-customerservice@teledyne.com

APPENDIX D – Wire List and Electronic Schematics

This page intentionally left blank.

T265 INTERCONNECT LIST

(Reference: 0739001A DCN6165)

Cable Part #	Signal	CONNECTION FROM				CONNECTION TO			
		Assembly	PN	J/P	Pin	Assembly	PN	J/P	Pin
0364901	CBL, AC POWER								
	AC Line	Power Entry	CN0000073		L	Power Switch	SW0000025		L
	AC Neutral	Power Entry	CN0000073		N	Power Switch	SW0000025		N
	Power Grnd	Power Entry	CN0000073			Shield	SW0000025		
	Power Grnd	Power Entry	CN0000073			Chassis			
	AC Line Switched	Power Switch	SW0000025		L	PS2 (+12)	060820000	SK2	1
	AC Neutral Switched	Power Switch	SW0000025		N	PS2 (+12)	060820000	SK2	3
	Power Grnd	Power Entry	CN0000073			PS2 (+12)	060820000	SK2	2
	AC Line Switched	Power Switch	SW0000025		L	PS1 (+5, ±15)	068010000	SK2	1
	AC Neutral Switched	Power Switch	SW0000025		N	PS1 (+5, ±15)	068010000	SK2	3
	Power Grnd	Power Entry	CN0000073			PS1 (+5, ±15)	068010000	SK2	2
	AC Line Switched	Power Switch	SW0000025		L	Relay PCA	045230100	J1	1
	AC Neutral Switched	Power Switch	SW0000025		N	Relay PCA	045230100	J1	3
	Power Grnd	Power Entry	CN0000073			Relay PCA	045230100	J1	2
03829	CBL, DC POWER TO MOTHERBOARD								
	DGND	Relay PCA	045230100	P7	1	Motherboard	058021100	P15	1
	+5V	Relay PCA	045230100	P7	2	Motherboard	058021100	P15	2
	AGND	Relay PCA	045230100	P7	3	Motherboard	058021100	P15	3
	+15V	Relay PCA	045230100	P7	4	Motherboard	058021100	P15	4
	AGND	Relay PCA	045230100	P7	5	Motherboard	058021100	P15	5
	-15V	Relay PCA	045230100	P7	6	Motherboard	058021100	P15	6
	+12V RET	Relay PCA	045230100	P7	7	Motherboard	058021100	P15	7
	+12V	Relay PCA	045230100	P7	8	Motherboard	058021100	P15	8
	Chassis Gnd	Relay PCA	045230100	P7	10	Motherboard	058021100	P15	9
04023	CBL, I2C, RELAY PCA TO MOTHERBOARD								
	I2C Serial Clock	Motherboard	058021100	P107	3	Relay PCA	045230100	P3	1
	I2C Serial Data	Motherboard	058021100	P107	5	Relay PCA	045230100	P3	2
	I2C Reset	Motherboard	058021100	P107	2	Relay PCA	045230100	P3	4
	I2C Shield	Motherboard	058021100	P107	6	Relay PCA	045230100	P3	5
04105	CBL, KEYBOARD, DISPLAY TO MOTHERBOARD								
	Kbd Interrupt	LCD Interface PCA	066970000	J1	7	Motherboard	058021100	J106	1
	DGND	LCD Interface PCA	066970000	J1	2	Motherboard	058021100	J106	8
	SDA	LCD Interface PCA	066970000	J1	5	Motherboard	058021100	J106	2
	SCL	LCD Interface PCA	066970000	J1	6	Motherboard	058021100	J106	6
	Shld	LCD Interface PCA	066970000	J1	10	Motherboard	058021100	J106	5
04176	CBL, DC POWER TO RELAY PCA								
	DGND	Relay PCA	045230100	P8	1	Power Supply Triple	068010000	J1	3
	+5V	Relay PCA	045230100	P8	2	Power Supply Triple	068010000	J1	1
	+15V	Relay PCA	045230100	P8	4	Power Supply Triple	068010000	J1	6
	AGND	Relay PCA	045230100	P8	5	Power Supply Triple	068010000	J1	4
	-15V	Relay PCA	045230100	P8	6	Power Supply Triple	068010000	J1	5
	+12V RET	Relay PCA	045230100	P8	7	Power Supply Single	068020000	J1	3
	+12V	Relay PCA	045230100	P8	8	Power Supply Single	068020000	J1	1
04433	CBL, PREAMPLIFIER TO RELAY PCA								
	Preamplifier DGND	Relay PCA	045230100	P9	1	Preamp PCA	041800500	P5	1
	Preamplifier +5V	Relay PCA	045230100	P9	2	Preamp PCA	041800500	P5	2
	Preamplifier AGND	Relay PCA	045230100	P9	3	Preamp PCA	041800500	P5	3
	Preamplifier +15V	Relay PCA	045230100	P9	4	Preamp PCA	041800500	P5	4
	Preamplifier -15V	Relay PCA	045230100	P9	6	Preamp PCA	041800500	P5	6
04437	CBL, PREAMPLIFIER TO TEC								
	Preamp TEC drive VREF	Preamp PCA	041800500	J1	1	TEC PCA	049310100	J3	1
	Preamp TEC drive CTRL	Preamp PCA	041800500	J1	2	TEC PCA	049310100	J3	2
	Preamp TEC drive AGND	Preamp PCA	041800500	J1	3	TEC PCA	049310100	J3	3

T265 INTERCONNECT LIST

(Reference: 0739001A DCN6165)

Cable Part #	Signal	CONNECTION FROM				CONNECTION TO			
		Assembly	PN	J/P	Pin	Assembly	PN	J/P	Pin
04671	CBL, MOTHERBOARD TO XMITTER BD (MULTIDROP OPTION)								
	GND	Motherboard	058021100	P12	2	Xmitter bd w/Multidrop	069500000	J4	2
	RX0	Motherboard	058021100	P12	14	Xmitter bd w/Multidrop	069500000	J4	14
	RTS0	Motherboard	058021100	P12	13	Xmitter bd w/Multidrop	069500000	J4	13
	TX0	Motherboard	058021100	P12	12	Xmitter bd w/Multidrop	069500000	J4	12
	CTS0	Motherboard	058021100	P12	11	Xmitter bd w/Multidrop	069500000	J4	11
	RS-GND0	Motherboard	058021100	P12	10	Xmitter bd w/Multidrop	069500000	J4	10
	RTS1	Motherboard	058021100	P12	8	Xmitter bd w/Multidrop	069500000	J4	8
	CTS1/485-	Motherboard	058021100	P12	6	Xmitter bd w/Multidrop	069500000	J4	6
	RX1	Motherboard	058021100	P12	9	Xmitter bd w/Multidrop	069500000	J4	9
	TX1/485+	Motherboard	058021100	P12	7	Xmitter bd w/Multidrop	069500000	J4	7
	RS-GND1	Motherboard	058021100	P12	5	Xmitter bd w/Multidrop	069500000	J4	5
	RX1	Motherboard	058021100	P12	9	Xmitter bd w/Multidrop	069500000	J4	9
	TX1/485+	Motherboard	058021100	P12	7	Xmitter bd w/Multidrop	069500000	J4	7
	RS-GND1	Motherboard	058021100	P12	5	Xmitter bd w/Multidrop	069500000	J4	5
06634	CBL, MAIN, M265E/T								
	TPMT	Motherboard	058021100	P109	4	Preamp PCA	041800500	P6	5
	HVPS	Motherboard	058021100	P109	5	Preamp PCA	041800500	P6	6
	PMT+	Motherboard	058021100	P109	6	Preamp PCA	041800500	P6	7
	AGND	Motherboard	058021100	P109	11	Shield			
	ETST	Motherboard	058021100	P108	8	Preamp PCA	041800500	P6	1
	OTST	Motherboard	058021100	P108	16	Preamp PCA	041800500	P6	2
	PRNG	Motherboard	058021100	P108	7	Preamp PCA	041800500	P6	4
	CH2	Motherboard	058021100	P109	2	P/Flow Sensor PCA	040030800	P1	4
	AGND	Relay PCA	045230100	P10	3	P/Flow Sensor PCA	040030800	P1	3
	+15V	Relay PCA	045230100	P10	4	P/Flow Sensor PCA	040030800	P1	6
	TEC +12V	Relay PCA	045230100	P10	8	TEC PCA	049310100	P1	1
	TEC +12V RET	Relay PCA	045230100	P10	7	TEC PCA	049310100	P1	2
	DGND	Relay PCA	045230100	P10	1	LCD Interface PCA	066970000	P14	8
	+5V	Relay PCA	045230100	P10	2	LCD Interface PCA	066970000	P14	1
	DGND	Relay PCA	045230100	P11	1	LCD Interface PCA	066970000	P14	2
	VCC	Relay PCA	045230100	P11	2	LCD Interface PCA	066970000	P14	3
	+12V RET	Relay PCA	045230100	P11	7	Chassis fan	040010000	P1	1
	+12V	Relay PCA	045230100	P11	8	Chassis fan	040010000	P1	2
	P/Flow Sensor AGND	Relay PCA	045230100	P11	3	P/Flow Sensor PCA	040030800	P1	3
	P/Flow Sensor +15V	Relay PCA	045230100	P11	4	P/Flow Sensor PCA	040030800	P1	6
	Pressure signal 1	Motherboard	058021100	P110	6	P/Flow Sensor PCA	040030800	P1	2
	Pressure signal 2	Motherboard	058021100	P110	5	P/Flow Sensor PCA	040030800	P1	4
	Flow signal 1	Motherboard	058021100	P110	4	P/Flow Sensor PCA	040030800	P1	5
	Flow signal 2	Motherboard	058021100	P110	3	P/Flow Sensor PCA	040030800	P1	1
	Shield	Motherboard	058021100	P110	12	P/Flow Sensor PCA	040030800	P1	S
	Shield	Motherboard	058021100	P110	9	Relay PCA	045230100	P17	S
	Thermocouple signal 1	Motherboard	058021100	P110	2	Relay PCA	045230100	P17	1
	TC 1 signal DGND	Motherboard	058021100	P110	8	Relay PCA	045230100	P17	2
	Thermocouple signal 2	Motherboard	058021100	P110	1	Relay PCA	045230100	P17	3
	TC 2 signal DGND	Motherboard	058021100	P110	7	Relay PCA	045230100	P17	4
06636	CBL, FAN								
	+12V	Relay PCA	045230100	P12	8	PMT cooling fan	013140000	P1	1
	+12V RET	Relay PCA	045230100	P12	7	PMT cooling fan	013140000	P1	2

T265 INTERCONNECT LIST

(Reference: 0739001A DCN6165)

Cable Part #	Signal	CONNECTION FROM				CONNECTION TO			
		Assembly	PN	J/P	Pin	Assembly	PN	J/P	Pin
06651	CBL, RX CELL THERM								
	Rcell thermistor A	Reaction cell thermistor	041920000	P1	2	Motherboard	058021100	P27	7
	Rcell thermistor B	Reaction cell thermistor	041920000	P1	1	Motherboard	058021100	P27	14
06652	CBL, Z/S, SAMP, AZ VALVES								
	Zero/Span valve +12V	Relay PCA	045230100	P4	1	Zero/Span valve	042680100	P1	1
	Zero/Span valve +12V RET	Relay PCA	045230100	P4	2	Zero/Span valve	042680100	P1	2
	Sample valve +12V	Relay PCA	045230100	P4	3	Sample valve	042680100	P1	1
	Sample valve +12V RET	Relay PCA	045230100	P4	4	Sample valve	042680100	P1	2
	AutoZero valve +12V	Relay PCA	045230100	P4	5	AutoZero valve	042680100	P1	1
	AutoZero valve +12V RET	Relay PCA	045230100	P4	6	AutoZero valve	042680100	P1	2
	NONOx valve +12V	Relay PCA	045230100	P4	7	NONOx valve	042680100	P1	1
	NONOx valve +12V RET	Relay PCA	045230100	P4	8	NONOx valve	042680100	P1	2
06653	CBL, RX CELL HTRS								
	Configuration jumper intern.	Relay PCA	045230100	P2	13	Relay PCA	045230100	P2	14
	Configuration jumper intern.	Relay PCA	045230100	P2	8	Relay PCA	045230100	P2	9
	Reaction cell heater/switch	Relay PCA	045230100	P2	1	Reaction cell heater 1B	040400000	P1	4
	Reaction cell heater/switch	Relay PCA	045230100	P2	1	Reaction cell heater 2B	040400000	P1	6
	Reaction cell heater/switch	Relay PCA	045230100	P2	2	Reaction cell heater 1A	040400000	P1	3
	Reaction cell heater/switch	Relay PCA	045230100	P2	3	Reaction cell heat switch	040400000	P1	1
	Reaction cell heater/switch	Relay PCA	045230100	P2	4	Reaction cell heat switch	040400000	P1	2
	Reaction cell heater/switch	Relay PCA	045230100	P2	5	Reaction cell heater 2A	040400000	P1	5
06737	CBL, I2C to AUX I/O (ANALOG IN OPTION)								
	ATX+	AUX I/O PCA	067300000	J2	1	Motherboard	058021100	J106	1
	ATX-	AUX I/O PCA	067300000	J2	2	Motherboard	058021100	J106	2
	LED0	AUX I/O PCA	067300000	J2	3	Motherboard	058021100	J106	3
	ARX+	AUX I/O PCA	067300000	J2	4	Motherboard	058021100	J106	4
	ARX-	AUX I/O PCA	067300000	J2	5	Motherboard	058021100	J106	5
	LED0+	AUX I/O PCA	067300000	J2	6	Motherboard	058021100	J106	6
	LED1+	AUX I/O PCA	067300000	J2	8	Motherboard	058021100	J106	8
06738	CBL, CPU COM to AUX I/O (USB OPTION)								
	RXD1	CPU PCA	067240000	COM1	1	AUX I/O PCA	0673000 or -02	J3	1
	DCD1	CPU PCA	067240000	COM1	2	AUX I/O PCA	0673000 or -02	J3	2
	DTR1	CPU PCA	067240000	COM1	3	AUX I/O PCA	0673000 or -02	J3	3
	TXD1	CPU PCA	067240000	COM1	4	AUX I/O PCA	0673000 or -02	J3	4
	DSR1	CPU PCA	067240000	COM1	5	AUX I/O PCA	0673000 or -02	J3	5
	GND	CPU PCA	067240000	COM1	6	AUX I/O PCA	0673000 or -02	J3	6
	CTS1	CPU PCA	067240000	COM1	7	AUX I/O PCA	0673000 or -02	J3	7
	RTS1	CPU PCA	067240000	COM1	8	AUX I/O PCA	0673000 or -02	J3	8
	RI1	CPU PCA	067240000	COM1	10	AUX I/O PCA	0673000 or -02	J3	10
06738	CBL, CPU COM to AUX I/O (MULTIDROP OPTION)								
	RXD	CPU PCA	067240000	COM1	1	Xmitter bd w/Multidrop	069500000	J3	1
	DCD	CPU PCA	067240000	COM1	2	Xmitter bd w/Multidrop	069500000	J3	2
	DTR	CPU PCA	067240000	COM1	3	Xmitter bd w/Multidrop	069500000	J3	3
	TXD	CPU PCA	067240000	COM1	4	Xmitter bd w/Multidrop	069500000	J3	4
	DSR	CPU PCA	067240000	COM1	5	Xmitter bd w/Multidrop	069500000	J3	5
	GND	CPU PCA	067240000	COM1	6	Xmitter bd w/Multidrop	069500000	J3	6
	CTS	CPU PCA	067240000	COM1	7	Xmitter bd w/Multidrop	069500000	J3	7
	RTS	CPU PCA	067240000	COM1	8	Xmitter bd w/Multidrop	069500000	J3	8
	RI	CPU PCA	067240000	COM1	10	Xmitter bd w/Multidrop	069500000	J3	10
06739	CBL, CPU LAN TO AUX I/O PCA								
	ATX-	CPU PCA	067240000	LAN	1	AUX I/O PCA	06730XXXX	J2	1
	ATX+	CPU PCA	067240000	LAN	2	AUX I/O PCA	06730XXXX	J2	2
	LED0	CPU PCA	067240000	LAN	3	AUX I/O PCA	06730XXXX	J2	3
	ARX+	CPU PCA	067240000	LAN	4	AUX I/O PCA	06730XXXX	J2	4
	ARX-	CPU PCA	067240000	LAN	5	AUX I/O PCA	06730XXXX	J2	5
	LED0+	CPU PCA	067240000	LAN	6	AUX I/O PCA	06730XXXX	J2	6
	LED1	CPU PCA	067240000	LAN	7	AUX I/O PCA	06730XXXX	J2	7
	LED1+	CPU PCA	067240000	LAN	8	AUX I/O PCA	06730XXXX	J2	8
06741	CBL, CPU USB to Front Panel								
	GND	CPU PCA	067240000	USB	8	LCD Interface PCA	066970000	JP9	
	LUSBD3+	CPU PCA	067240000	USB	6	LCD Interface PCA	066970000	JP9	
	LUSBD3-	CPU PCA	067240000	USB	4	LCD Interface PCA	066970000	JP9	
	VCC	CPU PCA	067240000	USB	2	LCD Interface PCA	066970000	JP9	

T265 INTERCONNECT LIST

(Reference: 0739001A DCN6165)

Cable Part #	Signal	CONNECTION FROM				CONNECTION TO			
		Assembly	PN	J/P	Pin	Assembly	PN	J/P	Pin
06746	CBL, MB TO 06154 CPU								
	GND	Motherboard	058021100	P12	2	Shield			
	RX0	Motherboard	058021100	P12	14	CPU PCA	067240000	COM1	1
	RTS0	Motherboard	058021100	P12	13	CPU PCA	067240000	COM1	8
	TX0	Motherboard	058021100	P12	12	CPU PCA	067240000	COM1	4
	CTS0	Motherboard	058021100	P12	11	CPU PCA	067240000	COM1	7
	RS-GND0	Motherboard	058021100	P12	10	CPU PCA	067240000	COM1	6
	RTS1	Motherboard	058021100	P12	8	CPU PCA	067240000	COM2	8
	CTS1/485-	Motherboard	058021100	P12	6	CPU PCA	067240000	COM2	7
	RX1	Motherboard	058021100	P12	9	CPU PCA	067240000	COM2	1
	TX1/485+	Motherboard	058021100	P12	7	CPU PCA	067240000	COM2	4
	RS-GND1	Motherboard	058021100	P12	5	CPU PCA	067240000	COM2	6
	RX1	Motherboard	058021100	P12	9	CPU PCA	067240000	485	1
	TX1/485+	Motherboard	058021100	P12	7	CPU PCA	067240000	485	2
	RS-GND1	Motherboard	058021100	P12	5	CPU PCA	067240000	485	3
WR256	CBL, TRANSMITTER TO INTERFACE								
		LCD Interface PCA	066970000	J15		Transmitter PCA	068810000	J1	

REVISIONS				
REV	DESCRIPTION	DATE	DCN	APPROVED
A	Initial Release	7/11/11	6165	KV

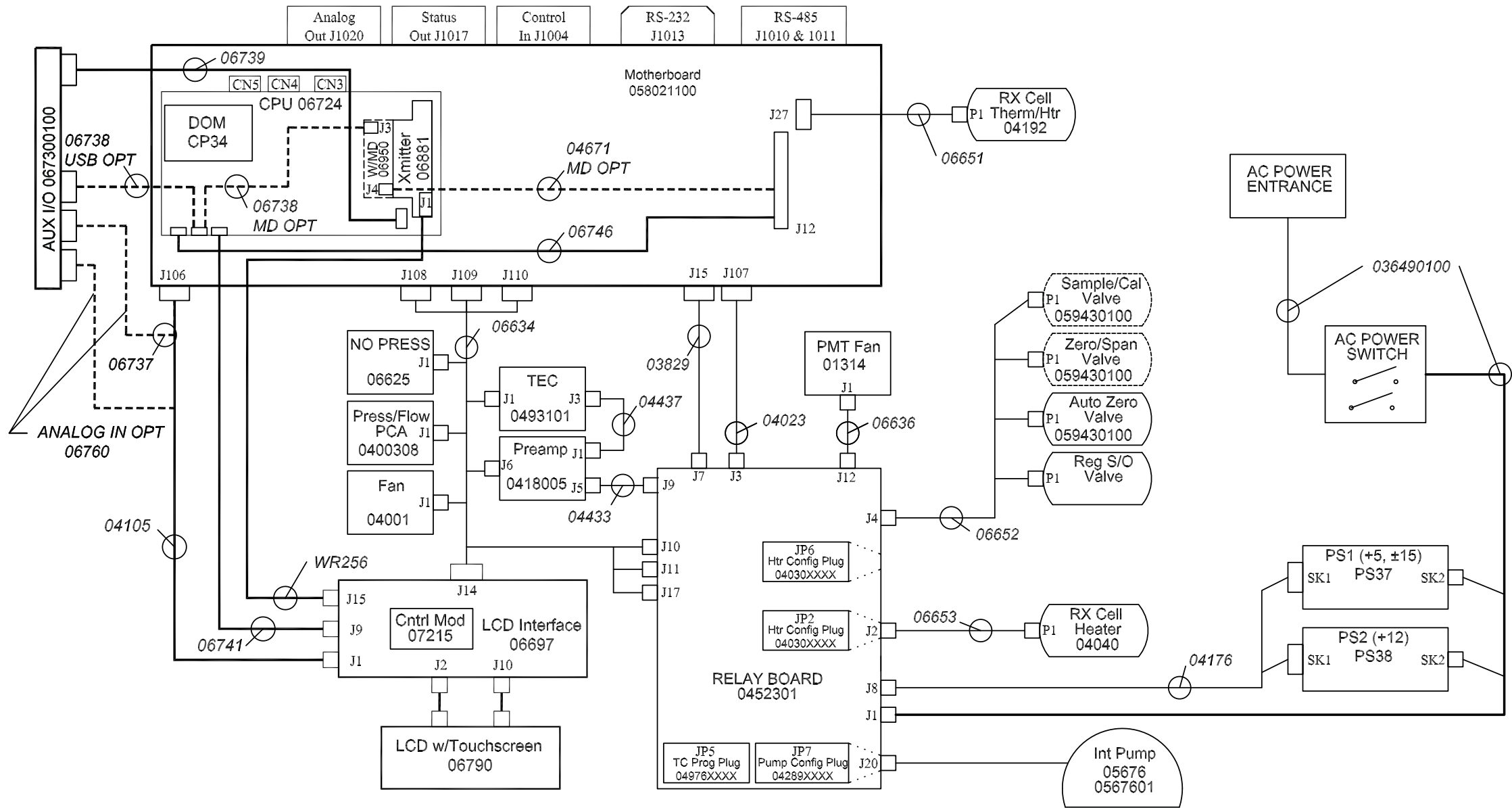

KEY:
 1. All part numbers in *Italic* identify cables that are referred to in the accompanying document 073900100
 2. All items in Dashed boxes are optional.

PRINTED DOCUMENTS ARE UNCONTROLLED

<p>The information herein is the property of API and is submitted in strictest confidence for reference only. Unauthorized use by anyone for any other purposes is prohibited. This document or an information contained in it may not be duplicated without proper authorization.</p> <p>THIRD ANGLE PROJECTION</p>	<p>UNLESS OTHERWISE SPECIFIED DIMENSIONS ARE IN INCHES</p> <p>TOLERANCES ARE:</p> <table border="1"> <tr> <th>FRACTIONS</th> <th>DECIMALS</th> <th>ANGULAR</th> </tr> <tr> <td>± 1/32</td> <td>±.03[0.76]</td> <td>±0° 30'</td> </tr> <tr> <td></td> <td>±.01[0.25]</td> <td></td> </tr> </table> <p>DO NOT SCALE DRAWING</p>	FRACTIONS	DECIMALS	ANGULAR	± 1/32	±.03[0.76]	±0° 30'		±.01[0.25]		<p>CONTRACT: NA</p>	<p>TELEDYNE Advanced Pollution Instrumentation A Teledyne Technologies Company</p>
	FRACTIONS	DECIMALS	ANGULAR									
	± 1/32	±.03[0.76]	±0° 30'									
		±.01[0.25]										
<p>FINISH NA</p>	<p>APPROVALS</p> <p>APPROVED: KV</p>	<p>DATE</p> <p>7/12/11</p>	<p>TITLE</p> <p>Interconnect Diagram</p>									
<p>SIMILAR TO</p>	<p>CHECK</p> <p>CCB</p>	<p>ISSUED</p>	<p>T265</p>									
			<table border="1"> <tr> <th>SIZE</th> <th>CAGE CODE NO.</th> <th>DWG. NO.</th> <th>REV</th> </tr> <tr> <td>B</td> <td>1JZF4</td> <td>07390</td> <td>A</td> </tr> </table>	SIZE	CAGE CODE NO.	DWG. NO.	REV	B	1JZF4	07390	A	
SIZE	CAGE CODE NO.	DWG. NO.	REV									
B	1JZF4	07390	A									