

Push Switch 2.5mm-travel Vertical Type

SPEC Series

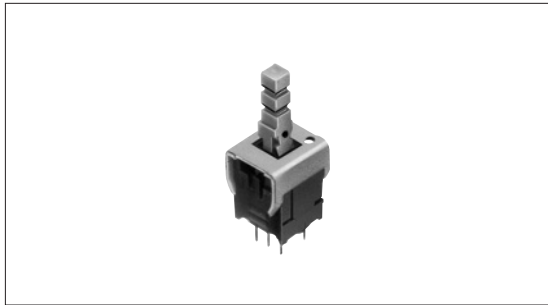

Vertical type, widely applicable to home and industrial electronic equipment.



Features

- 2.5mm-travel.
- Available in various types of standard knobs.

Applications

- For information related devices, audio equipment, telephones and various electronic devices
- For various types of switching in in-car (air conditioning) components and industrial electronic devices

Detector

Push

Slide

Rotary

Encoders

Power

Dual-in-line
Package Type

Multi Control
Devices

TACT Switch™

Custom-
Products

Horizontal
Type

Vertical
Type

Typical Specifications

Items		Specifications
Rating (max.) / (min.) (Resistive load)		0.1A 30V DC/50 μ A 3V DC
Contact resistance (Initial /After operating life)		30m Ω max./50m Ω max.
Operating force	2-poles	2 \pm 1N
Operating life	Without load	10,000cycles
	With load	10,000cycles (0.1A 30V DC)

Product Line

Changeover timing	Travel (mm)	Total travel (mm)	Mounting method	Poles	Operation	Terminal Configuration	Minimum packing unit (pcs.)	Product No.
Non shorting	2.5	3.4	PC board	2	Latching	Straight	100	SPEC121100
						Snap-in		SPEC121300

Note

Products other than those listed in the above chart are also available. Please contact us for details.

Refer to P.105 for product specifications.
Refer to P.106 for knobs.

- Detector
- Push**
- Slide
- Rotary
- Encoders
- Power
- Dual-in-line
Package Type
- Multi Control
Devices
- TACT Switch™
- Custom-
Products

Dimensions

Unit:mm

Style	PC board mounting hole dimensions (Viewed from the direction A)	
	<p>Straight terminal</p>	<p>Snap-in terminal</p>

- Horizontal
Type
- Vertical
Type**

Actuator configuration at front edge Unit:mm

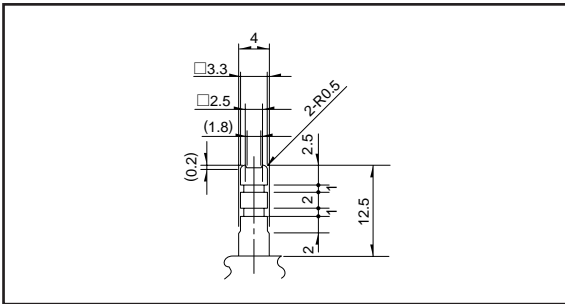

Circuit Diagram (Viewed from the Direction A)

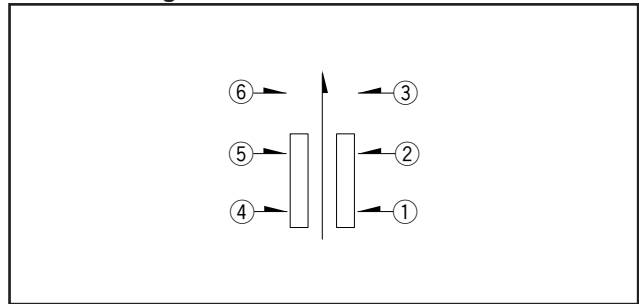

Terminal Configuration

Unit:mm

Straight terminal	Snap-in terminal

Product Specifications

Series		SPEE	SPPJ6	SPPJ2	SPPJ3	SPUJ SPUP ※1	SPUN ※1	SPUN (medium current) ※1	SPPH2	SPPH4	SPPH1	SPEA	SPEC	SPED2	SPED3	SPED4	SPED5	SPEF	
Item	Operating temperature range	-10°C to +60°C		-40°C to +85°C		-10°C to +60°C					-40°C to +85°C	-10°C to +60°C	-40°C to +85°C						
	Rating (max.) (Resistive load)	5V 20mA	0.2A 12V DC	0.2A 30V DC		0.1A 30V DC		1A 25V DC	0.1A 12V DC	0.1A 30V DC			1A 14.5V DC						
Electrical performance	Initial contact resistance	※2	20mΩ max.					30mΩ max.	100mΩ max.	20mΩ max.	30mΩ max.		100mΩ max.						
	Insulation resistance	10mΩ min. 100V DC	100MΩ min. 500V DC															3MΩ min. 500V DC	3MΩ min. 100V DC
	Voltage proof	100V AC for 1minute	500V AC for 1minute											100V AC for 1minute		100V AC for 1minute			
Mechanical performance	Terminal strength	5N for 1minute									3N for 1minute		—						
	Actuator strength	Operating direction	50N	30N	50N		30N		50N					90N					
		Pulling direction	—		24.6350N		—	10N	—	50N		—			30N				
	Vibration	10 to 55 to 10Hz/min., the amplitude is 1.5mm for all the frequencies, in the 3 direction of X, Y and Z for 2 hours respectively																	
	Resistance to soldering heat	Manual soldering	350±10°C 4±0s	350±10°C 3 ⁺¹ ±1s		300±10°C 3 ⁺¹ ±1s	350±10°C 3 ⁺¹ ±1s		350°C max. 3s max.	350±10°C 3 ⁺¹ ±1s			350±10°C 3±0.5s	—	350±10°C 3±0.5s	—	350±5°C 3s max.		
Dip soldering		—	260±5°C 5±1s	260±5°C 10±1s	260±5°C 5±1s	260±5°C 10±1s		260±5°C 5±1s	260±5°C 10±1s	260±5°C 5±1s	260°C max. 5s max.	260±5°C 10±1s	—	260±5°C 10±1s	—	260±5°C 10±1s			
Reflow	Please see P.107																		
Durability	Operating life without load	100,000 cycles	10,000 cycles 40mΩ max.			30,000cycles 40mΩ max.	10,000cycles 40mΩ max.	10,000cycles 50mΩ max.	10,000cycles 100mΩ max.	10,000cycles 40mΩ max.	10,000cycles 50mΩ max.		30,000cycles 100Ω max.						
	Operating life with load Load : As rating	100,000 cycles	10,000 cycles 40mΩ max.			5,000 cycles 40mΩ max.	10,000 cycles 50mΩ max.	10,000 cycles 100mΩ max.	10,000 cycles 40mΩ max.	10,000 cycles 50mΩ max.		30,000cycles 100mΩ max.							
Environmental performance	Cold	-40±2°C for 96h	-20±2°C for 96h										-40±2°C for 96h						
	Dry heat	85±2°C for 96h																	
	Damp heat	40±2°C, 90 to 95%RH for 96h																	

Notes

- ※1. The operating temperature range for automotive applications can be raised upon request. Please contact us for requirements of this kind.
- ※2. 1V or less, at the present rating of 1mA, 5V DC for output voltage.

Detector

Push

Slide

Rotary

Encoders

Power

Dual-in-line
Package Type

Multi Control
Devices

TACT Switch™

Custom-
Products

Horizontal
Type

Vertical
Type

Attached Parts

Please specify required knob.

Unit:mm

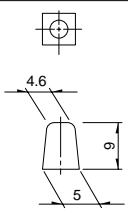
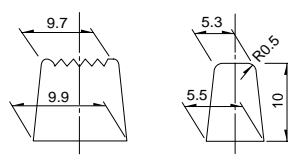
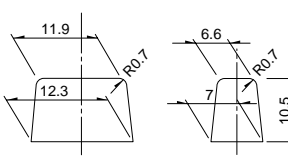
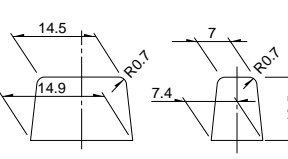
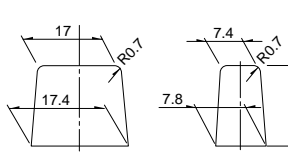
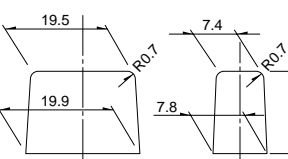
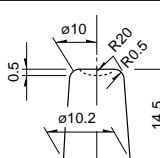
Knob outline drawing	Variety		Series
	Color	Model	
		UJ206022 UJ206020 UJ206026	SPPJ3 SPUJ
Key pitch 10mm Square knob 		4093-1 4093-2 4093-3	
Key pitch 12.5mm Square knob 		UE201011 UE201012 UE201013	
Key pitch 15mm Square knob 	Black Red White	UE202011 UE202012 UE202013	SPPJ2 SPUP SPUN SPEC
Key pitch 17.5mm Square knob 		UE203011 UE203012 UE203013	
Key pitch 20mm Square knob 		UE204011 UE204012 UE204013	
Round knob 		UE200011 UE200012 UE200013	

Note

We recommend the use of adhesive to secure the knob when mounting onto switches.

