



9.9A
15A

OWNER'S MANUAL

U.S.A. Edition
LIT-18626-04-53

⚠ WARNING

The engine exhaust from this product contains chemicals known to the State of California to cause cancer, birth defects or other reproductive harm.

YAMAHA

LIT-CALIF-65-01

TO THE OWNER

Thank you for choosing a Yamaha outboard motor. This Owner's manual contains information needed for proper operation, maintenance and care. A thorough understanding of these simple instructions will help you obtain maximum enjoyment from your new Yamaha. If you have any question about the operation or maintenance of your outboard motor, please consult a Yamaha dealer.

In this Owner's Manual particularly important information is distinguished in the following ways.



The Safety Alert Symbol means **ATTENTION! BECOME ALERT! YOUR SAFETY IS INVOLVED!**

WARNING

Failure to follow WARNING instructions could result in severe injury or death to the machine operator, a bystander, or a person inspecting or repairing the outboard motor.

CAUTION:

A CAUTION indicates special precautions that must be taken to avoid damage to the outboard motor.

NOTE:

A NOTE provides key information to make procedures easier or clearer.

* Yamaha continually seeks advancements in product design and quality. Therefore, while this manual contains the most current product information available at the time of printing, there may be minor discrepancies between your machine and this manual. If there is any question concerning this manual, please consult your Yamaha dealer.

NOTE:

The 15MH and its standard accessories are used as a base for the explanations and illustrations in this manual. Therefore, some items may not apply to every model.

**9.9A/15A
OWNER'S MANUAL
©2001 by Yamaha Motor Corporation, USA
1st Edition, March 2001
All rights reserved.
Any reprinting or unauthorized use
without the written permission of
Yamaha Motor Corporation, USA
is expressly prohibited.
Printed in Japan
P/N LIT-18626-04-53**

CONTENTS

E



GENERAL INFORMATION

1



BASIC COMPONENTS

2



OPERATION

3



MAINTENANCE

4



TROUBLE RECOVERY

5



INDEX

6

**READ THIS OWNER'S MANUAL CAREFULLY
BEFORE OPERATING YOUR OUTBOARD MOTOR.**

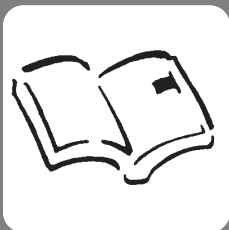

EMB00010

Chapter 1

GENERAL INFORMATION

1



IDENTIFICATION NUMBERS

RECORD1-1

Outboard motor serial number.....1-1

EMISSION CONTROL INFORMATION...1-2

SAFETY INFORMATION.....1-3

IMPORTANT LABELS1-5

Warning labels.....1-5

BASIC BOATING RULES1-6

FUELING INSTRUCTIONS.....1-10

Gasoline(petrol).....1-11

Engine oil1-11

PROPELLER SELECTION1-12

START-IN-GEAR PROTECTION1-13



EMU00005

IDENTIFICATION NUMBERS RECORD

EMU00007

OUTBOARD MOTOR SERIAL NUMBER

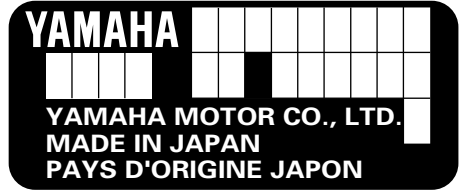
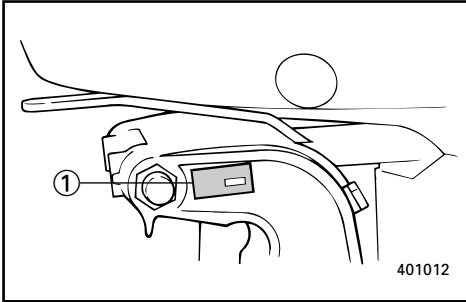

The outboard motor serial number is stamped on the label attached to the port side of the clamp-bracket.

Record your outboard motor serial number in the spaces provided to assist you in ordering spare parts from your Yamaha dealer or for reference in case your outboard motor is stolen.

- ① Outboard motor serial number

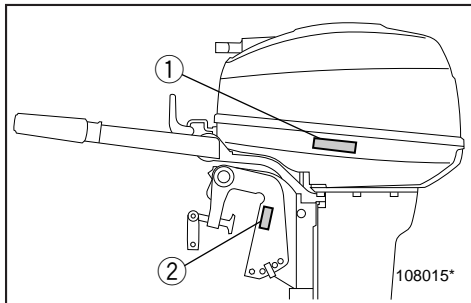

EMU01385

EMISSION CONTROL INFORMATION

EMU01386

NORTH AMERICAN MODELS

This engine conforms to U.S. Environmental Protection Agency (EPA) regulations for marine SI engines. See the label affixed to your engine for details.

Approval label of Emission control certificate

This label is attached to the bottom cowling.

① Emission control information label

EMISSION CONTROL INFORMATION	
ENGINE FAMILY : [.....]	
THIS ENGINE CONFORMS TO [.....] U.S. EPA REGULATIONS FOR MARINE SI ENGINES.	
FELS : [.....] g/kw-hr	IDLE SPEED : [.....] rpm IN NEUTRAL
SPARK PLUG : [.....]	SPARK PLUG GAP (mm) : [.....]
YAMAHA MOTOR CO.,LTD. [.....]	

Existing Technology ; N/A

Manufactured date label

This label is attached to the clamp bracket or the swivel bracket.

② Manufactured date label

YAMAHA
Manufactured: [][][][][][]



EMU00917



SAFETY INFORMATION

- Before mounting or operating the outboard motor, read this entire manual. Reading it should give you an understanding of the motor and its operation.
- Before operating the boat, read any owner's or operator's manuals supplied with it and all labels. Be sure you understand each item before operating.
- Do not overpower the boat with this outboard motor. Overpowering the boat could result in loss of control. The rated power of the outboard should be equal to or less than the rated horsepower capacity of the boat. If the rated horsepower capacity of the boat is unknown, consult the dealer or boat manufacturer.
- Do not modify the outboard. Modifications could make the motor unfit or unsafe to use.
- Never operate after drinking alcohol or taking drugs. About 50% of all boating fatalities involve intoxication.
- Have an approved personal flotation device (PFD) on board for every occupant. It is a good idea to wear a PFD whenever boating. At a minimum, children and non-swimmers should always wear PFDs, and everyone should wear PFDs when there are potentially hazardous boating conditions.
- Gasoline is highly flammable, and its vapors are flammable and explosive. Handle and store gasoline carefully. Make sure there are no gas fumes or leaking fuel before starting the engine.
- This product emits exhaust gases which contain carbon monoxide, a colorless, odorless gas which may cause brain damage or death when inhaled. Symptoms include nausea, dizziness, and drowsiness. Keep cockpit and cabin areas well ventilated. Avoid blocking exhaust outlets.
- Check throttle, shift, and steering for proper operation before starting the engine.
- Attach the engine stop switch lanyard to a secure place on your clothing, or your arm or leg while operating. If you accidentally leave the helm, the lanyard will pull from the switch, stopping the engine.
- Know the marine laws and regulations where you will be boating - and obey them. Refer to the "RULES OF THE ROAD" section for basic boating rules.
- Stay informed about the weather. Check weather forecasts before boating. Avoid boating in hazardous weather.
- Tell someone where you are going: leave a Float Plan with a responsible person. Be sure to cancel the Float Plan when you return.
- Use common sense and good judgment when boating. Know your abilities, and be sure you understand how your boat handles under the different boating conditions you may encounter. Operate within your limits, and the limits of your boat. Always operate at safe speeds, and keep a careful watch for obstacles and other traffic.
- Always watch carefully for swimmers during the engine operation.
- Stay away from swimming areas.
- When a swimmer is in the water near you shift into neutral and shut off the engine.



- Be informed about boating safety. Additional publications and information can be obtained from many organizations, including the following:

United States Coast Guard

Consumer Affairs Staff (G-BC)
Office of Boating, Public, and Consumer Affairs
U.S. Coast Guard Headquarters
Washington, D.C. 20593-0001
Boating Safety Hotline: 1-800-368-5647

National Marine Manufacturers

Association (NMMA)

401 N. Michigan Ave.
Chicago, IL 60611

Marine Retailers Association of America

155 N. Michigan Ave.
Chicago, IL 60601



EMB30010

IMPORTANT LABELS WARNING LABELS

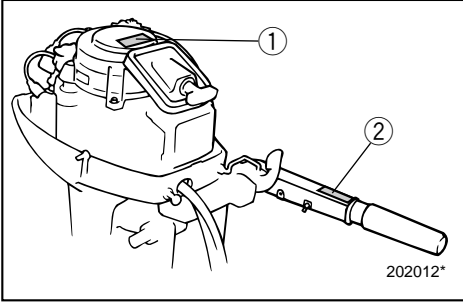

①



WARNING

- Be sure shift control is in neutral before starting engine. (except 2HP)
- Do not touch or remove electrical parts when starting or during operation.
- Keep hands, hair, and clothes away from flywheel and other rotating parts while engine is running.

YAMAHA

6A1-83625-01

②



WARNING

This engine is equipped with a neutral starting device. The engine will not start unless the shift control is in neutral position.

YAMAHA

6E0-83627-01



BASIC BOATING RULES (Rules of the road)

Just as there are rules which apply when you are driving on streets and high ways, there are waterway rules which apply when you are driving your boat. These rules are used internationally, and are also enforced by the United States Coast Guard and local agencies. You should be aware of these rules, and follow them whenever you encounter another vessel on the water.

Several sets of rules prevail according to geographic location, but are all basically the same as the International Rules of the Road. The rules presented here in your Owner's Manual are condensed, and have been provided for your convenience only. Consult your local U.S. Coast Guard Auxiliary or Department of Motor Vehicles for a complete set of rules governing the waters in which you will be using your boat.

STEERING AND SAILING RULES AND SOUND SIGNALS

Whenever two vessels on the water meet one another, one vessel has the right-of-way; it is called the "stand-on" vessel. The vessel which does not have the right-of-way is called the "give-way" or "burdened" vessel. These rules determine which vessel has the right-of-way, and what each vessel should do.

Stand-on Vessel

The vessel with the right-of-way has the duty to continue its course and speed, except to avoid an immediate collision. When you maintain your direction and speed, the other vessel will be able to determine how best to avoid you.

Give-way Vessel

The vessel which does not have the right-of-way has the duty to take positive and timely action to stay out of the way of the Stand-On vessel. Normally, you should not cross in front of the vessel with the right-of-way. You should slow down or change directions briefly and pass behind the other vessel. You should always move in such a way that the operator of the other vessel can see what you are doing.

"The general prudential rule"

This rule is called Rule 2 in the International Rules and says,

'In obeying and construing these rules due regard shall be had to all dangers of navigation and collision, and to any special circumstances, which may render a departure from the above rules necessary in order to avoid immediate danger.'

In other words, follow the standard rules except when a collision will occur unless both vessels try to avoid each other. If that is the case, both vessels become "Give-Way" vessels.



RULES WHEN ENCOUNTERING VESSELS

There are three main situations which you may encounter with other vessels which could lead to a collision unless the Steering Rules are followed:

Meeting

(you are approaching another vessel head-on)

Crossing

(you are travelling across the other vessel's path)

Overtaking

(you are passing or being passed by another vessel)

In the following illustration, your boat is in the center. You should give the right-of-way to any vessels shown in white area (you are the Give-Way vessel). Any vessels in the shaded area must yield to you (they are the Give-Way vessels). Both you and the meeting vessel must alter course to avoid each other.

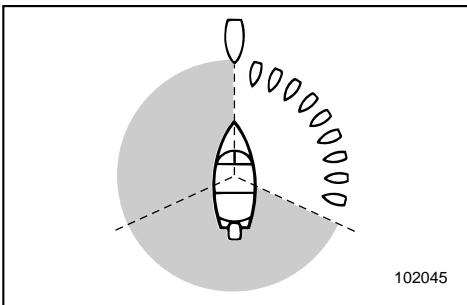

Meeting

If you are meeting another power vessel head on, and are close enough to run the risk of collision, neither of you has the right-of-way! Both of you should alter course to avoid an accident. You should keep the other vessel on your port (left)

side. This rule doesn't apply if both of you will clear one another if you continue on your set course and speed.

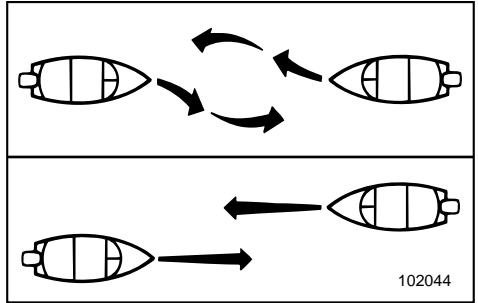

Crossing

When two power driven vessels are crossing each other's path close enough to run the risk of collision, the vessel which has the other on the starboard (right) side must keep out of the way of the other. If the other vessel is on your right, you must keep out of its way; you are the Give-Way vessel. If the other vessel is on your port (left) side, remember that you should maintain course and direction, provided the other vessel gives you the right-of-way as it should.

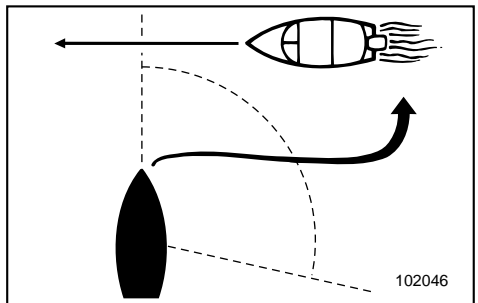

Overtaking

If you are passing another vessel, you are the "Give-Way" vessel. This means that the other vessel is expected to maintain its course and speed. You must stay out



of its way until you are clear of it. Likewise, if another vessel is passing you, you should maintain your speed and direction so that the other vessel can steer itself around you.

OTHER SPECIAL SITUATIONS

There are three other rules you should be aware of when driving your boat around other vessels.

Narrow Channels and Bends

When navigating in narrow channels, you should keep to the right when it is safe and practical to do so. If the operator of a power-driven vessel is preparing to go around a bend that may obstruct the view of other water vessels, the operator should sound a prolonged blast on the whistle (4 to 6 seconds). If another vessel is around the bend, it too should sound the whistle. Even if no reply is heard, however, the vessel should still proceed around the bend with caution. If you navigate such waters with your boat, you will need to carry a portable air horn, available from local marine supply stores.

Fishing Vessel Right-of-way

All vessels which are fishing with nets, lines or trawls are considered to be "fishing vessels" under the International Rules. Vessels with trolling lines are not considered fishing vessels. Fishing vessels have the right-of-way regardless of position. Fishing vessels cannot, however, impede the passage of other vessels in narrow channels.

Sailing Vessel Right-of-way

Sailing vessels should normally be given the right-of-way. The exceptions to this are:

1. When the sailing vessel is overtaking the power-driven vessel, the power-driven vessel has the right-of-way.
2. Sailing vessels should keep clear of any fishing vessel.
3. In a narrow channel, a sailing vessel should not hamper the safe passage of a power-driven vessel which can navigate only in such a channel.

Reading Buoys and Other Markers

The waters of the United States are marked for safe navigation by the lateral system of buoyage. Simply put, buoys and markers have an arrangement of shapes, colors, numbers and lights to show which side of the buoy a boater should pass on when navigating in a particular direction. The markings on these buoys are oriented from the perspective of being entered from seaward (the boater is going towards the port). This means that red buoys are passed on the starboard (right) side when proceeding from open water into port, and black buoys are to port (left) side. When navigating out of port, your position with respect to the buoys should be reversed; red buoys should be to port and black buoys to starboard.

Many bodies of water used by boaters are entirely within the boundaries of a particular state. The Uniform State Waterway Marking System has been devised for these waters. This system uses buoys and signs with distinctive shapes and colors to show regulatory or advisory information. These markers are white with black letters and orange borders. They signify speed zones, restricted areas, danger areas, and general information.



Remember, markings may vary by geographic location. Always consult local boating authorities before driving your boat in unfamiliar waters.

<p>BUOY COLOR CODE</p> <ul style="list-style-type: none"> BLACK RED GREEN 	<p>MAIN CHANNEL BUOYS</p>
<p>SECONDARY CHANNEL BUOYS STARTS NEW NUMBERING SYSTEM</p>	<p>"1" "3" "5" "7"</p> <p>LIGHTED BUOY (Port Hand)</p> <p>Odd number, increasing toward head of navigation. Leave to port (left) proceeding upstream.</p> <p>White Light OR Green Light</p> <p>old OR new</p>
<p>C "1"</p> <p>CAN BUOY</p> <p>Odd number. Leave to port.</p> <p>old OR new</p>	<p>"2" "4" "6"</p> <p>LIGHTED BUOY (Starboard Hand)</p> <p>Even number, increasing toward head of navigation. Leave to starboard (right) proceeding upstream.</p> <p>White Light OR Red Light</p> <p>old OR new</p>
<p>N "2"</p> <p>NUN BUOY</p> <p>Even number. Leave to starboard</p> <p>No change</p>	<p>"A"</p> <p>LIGHTED SAFE WATER BUOY</p> <p>No number. Marks midchannel, pass on either side. Letter has no lateral significance, used for identification and location purposes.</p> <p>White Light OR Top Mark White Light</p> <p>old OR new</p>
	<p>RB "L" OR RG "L"</p> <p>LIGHTED PREFERRED CHANNEL TO PORT BUOY</p> <p>No number. Topmost band red - preferred channel is to left of buoy. Letter has no lateral significance, used for identification and location purposes.</p> <p>Red or White Light OR Red Light</p> <p>old OR new</p>



EMU00016

FUELING INSTRUCTIONS

⚠ WARNING

GASOLINE AND ITS VAPORS ARE HIGHLY FLAMMABLE AND EXPLOSIVE!

- Do not smoke when refueling, and keep away from sparks, flames, or other sources of ignition.
- Stop engine before refueling.
- Refuel in a well-ventilated area. Refuel portable fuel tanks off the boat.
- Take care not to spill gasoline. If gasoline spills, wipe it up immediately with dry rags.
- Do not overfill the fuel tank.
- Tighten the filler cap securely after refueling.
- If you should swallow some gasoline inhale a lot of gasoline vapor, or get gasoline in your eyes, get immediate medical attention.
- If any gasoline spills onto your skin, immediately wash with soap and water. Change clothing if gasoline spills on it.
- Touch the fuel nozzle to the filler opening or funnel to help prevent electrostatic sparks.

CAUTION:

Use only new clean gasoline which has been stored in clean containers and is not contaminated with water or foreign matter.



EMU00018

GASOLINE (PETROL)

Recommended gasoline:

Regular unleaded gasoline with a minimum octane rating of 86
(Pump octane number) = $(R+M)/2$

If knocking or pinging occurs, use a different brand of gasoline or premium unleaded fuel. If unleaded gasoline is not available, then leaded regular gasoline can be used.

EMU00027

Gasohol

There are two types of gasohol: gasohol containing ethanol and that containing methanol. Gasohol containing ethanol can be used if ethanol content does not exceed 10% and the fuel meets minimum octane ratings. Gasohol containing methanol is not recommended by Yamaha because it can cause fuel system damage or engine performance problems.

EMU00858

ENGINE OIL

Recommended oil:

YAMALUBE 2 STROKE OUTBOARD OIL

If the recommended engine oil is not available, another 2-stroke engine oil with a NMMA-certified TC-W3 rating may be used.



PROPELLER SELECTION

The performance of your outboard motor will be critically affected by your choice of propeller, as an incorrect choice could adversely affect performance and could also seriously damage the motor. Engine speed depends on the propeller size and boat load. If engine speed is too high or too low for good engine performance, this will have an adverse effect on the engine.

Yamaha outboard motors are fitted with propellers chosen to perform well over a range of applications, but there may be uses where a propeller with a different pitch would be more appropriate. For a greater operating load, a smaller-pitch propeller is more suitable as it enables the correct engine speed to be maintained. Conversely, a larger-pitch propeller is more suitable for a smaller operating load.

Yamaha dealers stock a range of propellers, and can advise you and install a propeller on your outboard that is best suited to your application.

**NOTE:** _____

At full throttle and under a maximum boat load, the engine's rpm should be within the upper half of the full throttle operating range, as listed in "SPECIFICATIONS" on page 4-1. Select a propeller which fulfills this requirement.

If operating under conditions which allow the engine's rpm to rise above the maximum recommended range (such as light boat loads), reduce the throttle setting to maintain the rpm in the proper operating range.

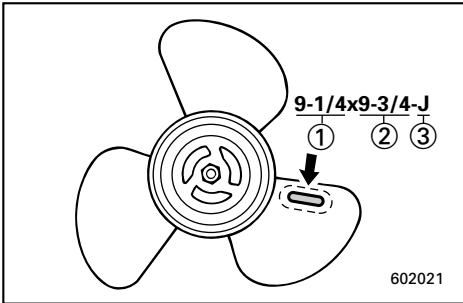

- ① Propeller diameter (in inches)
- ② Propeller pitch (in inches)
- ③ Type of propeller (propeller mark)

Refer to the section "CHECKING PROPELLER" for instructions on propeller removal and installation.

EMU01209

START-IN-GEAR PROTECTION

Yamaha outboard motors or Yamaha approved remote control units are equipped with start-in-gear protection device(s). This feature permits the engine to be started only when it is Neutral. Always select Neutral before starting the engine.

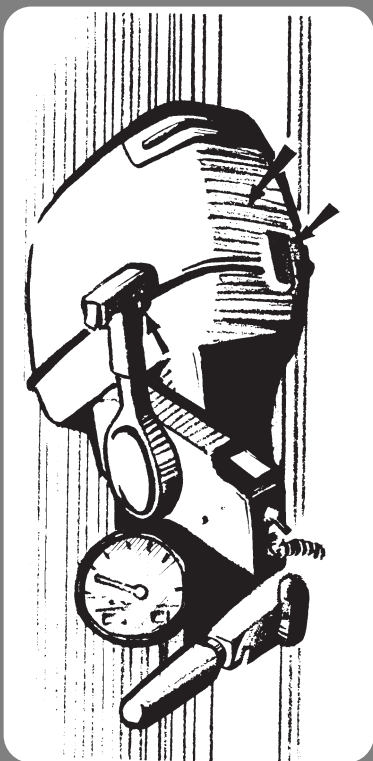
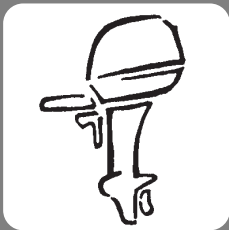

EMC00010

Chapter 2

BASIC COMPONENTS

MAIN COMPONENTS.....2-1

OPERATIONS OF CONTROLS AND
OTHER FUNCTIONS2-2

Fuel tank2-2

Gear shift lever2-2

Engine stop button.....2-3

Engine stop lanyard switch2-3

Throttle control grip2-4

Choke knob2-4

Recoil starter handle2-4

Tiller handle2-5

Steering friction adjustment2-6

Trim angle adjusting rod2-6

Tilt lock mechanism2-6

Tilt support bar2-7

Top cowling lock lever2-7

Carrying handle2-7



EMU01206

MAIN COMPONENTS

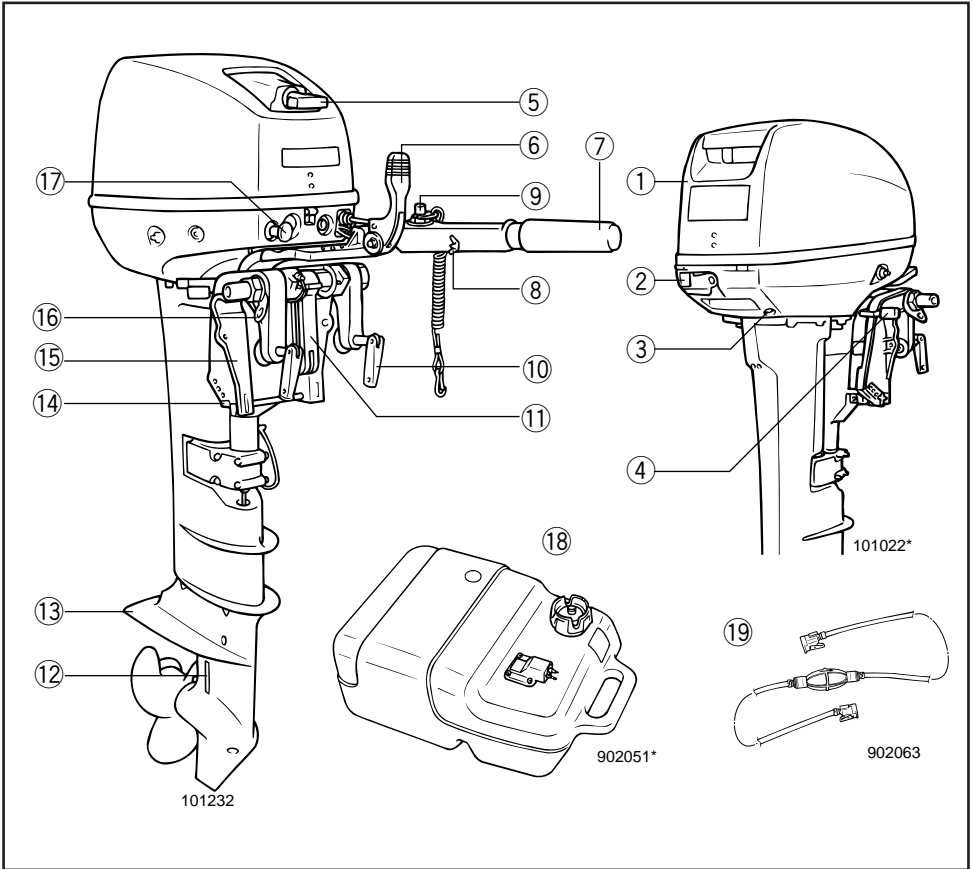

- ① Top cowling
- ② Cowling lock lever
- ③ Cooling water pilot hole
- ④ Tilt lock lever
- ⑤ Recoil starter handle
- ⑥ Gear shift lever
- ⑦ Throttle control grip
- ⑧ Throttle friction adjustment knob
- ⑨ Engine stop button/
Engine stop lanyard switch
- ⑩ Clamp screw
- ⑪ Carrying handle
- ⑫ Cooling water inlet
- ⑬ Anti-cavitation plate
- ⑭ Trim angle adjusting rod
- ⑮ Clamp bracket
- ⑯ Rope attachment

* May not be exactly as shown; also may not be included as standard equipment on all models.



EMC20010

OPERATIONS OF CONTROLS AND OTHER FUNCTIONS

EMC21012

FUEL TANK

If your model was equipped with a portable fuel tank, its function is as follows.

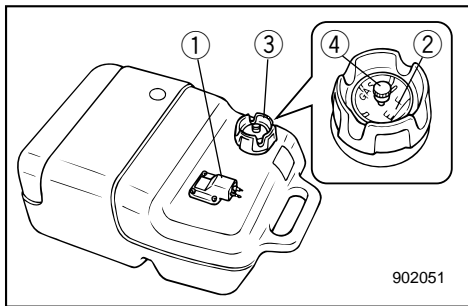

- ① Fuel hose joint
- ② Fuel meter (If equipped)
- ③ Fuel tank cap
- ④ Air vent screw (If equipped)

Fuel hose joint

This connector is provided for connecting or disconnecting fuel hose.

Fuel meter

This meter is on the fuel tank cap. It shows current fuel quantity in the fuel tank approximately.

Fuel tank cap

This cap is for filling fuel. To remove it, turn it counterclockwise.

Air Vent screw

This screw is on the fuel tank cap. To loosen it, turn it counterclockwise.

EMC25010

GEAR SHIFT LEVER

(for Tiller control model):

Turning the gear-shift lever towards you engages the clutch with the forward gear so that the boat moves ahead. Turning the lever away from you engages the reverse gear so that the boat moves astern.

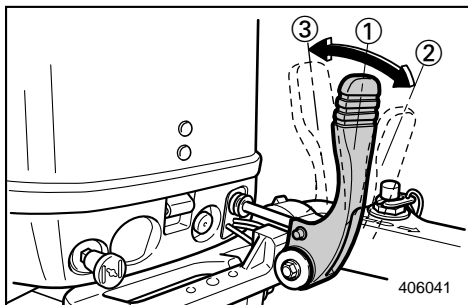

- ① Neutral
- ② Forward
- ③ Reverse

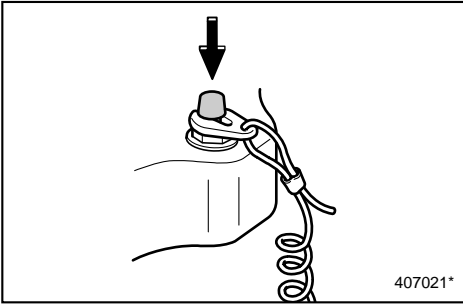

EMC27011

ENGINE STOP BUTTON (for Tiller control model)

Pushing this button opens the ignition circuit and stops the engine.

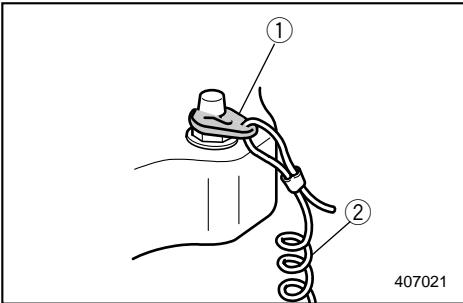

EMU00931

ENGINE STOP LANYARD SWITCH (for Tiller control model)

The lock-plate ① must be attached to the engine stop lanyard switch for the engine to run. The lanyard ② should be attached to a secure place on the operator's clothing, or arm or leg. Should the operator fall overboard or leave the helm, the lanyard will pull out the lock plate, stopping ignition to the engine. This will prevent the boat from running away under power.

⚠ WARNING

- Attach the lanyard to a secure place on your clothing, your arm or leg while operating.
- Do not attach the lanyard to clothing that could tear loose. Do not route the lanyard in such a way that it could become entangled, preventing it from functioning.
- Avoid accidentally pulling the lanyard during normal operation. Loss of engine power means the loss of most steering control. Also, without engine power, the boat could slow rapidly. This could cause people and objects in the boat to be thrown forward.

NOTE:

The engine cannot be started with the lock-plate removed.

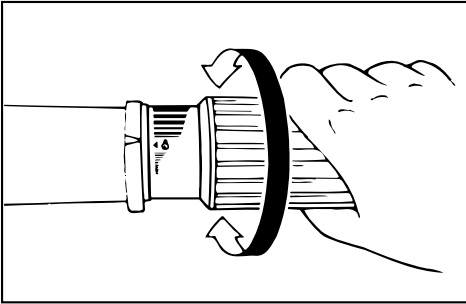

EMC40010

**THROTTLE CONTROL GRIP
(for Tiller control model)**

The throttle control grip is on the tiller handle. Turn the grip counterclockwise to increase speed and clockwise to decrease speed.

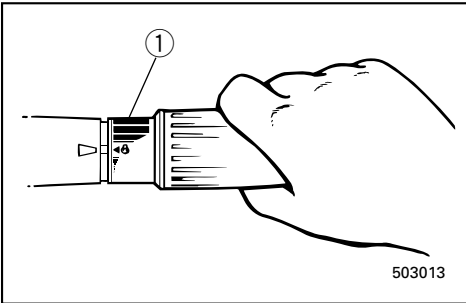

Throttle indicator

The fuel consumption curve on the throttle indicator shows the relative amount of fuel consumed for each throttle position. Choose the setting that offers the best performance and fuel economy for the desired operation.

① Throttle indicator

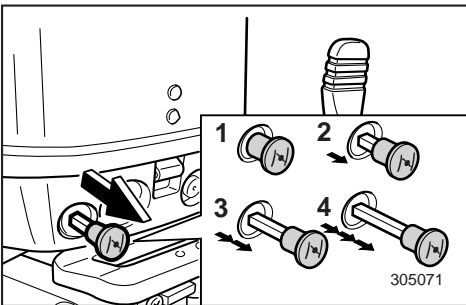

EMC42310

CHOKE KNOB

Pulling out this knob supplies a rich mixture required to start or warm up the engine. There are 4 operating position as shown below :

Position	Function
1	To start a hot engine
2 or 3	To warm up a cold engine or restart a warm engine
4	To start a cold engine

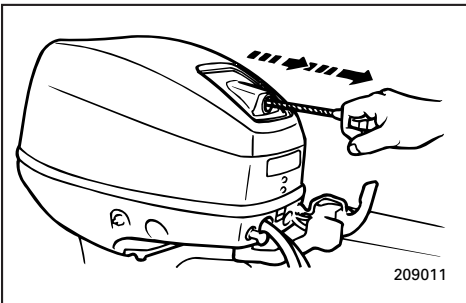

EMC44010

**RECOIL STARTER HANDLE
(If equipped)**

Pull the handle gently until resistance is felt. Then vigorously pull the handle straight out to crank the engine to start it.

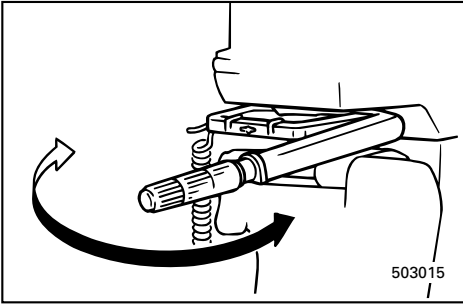

EMC60010

**TILLER HANDLE
(for Tiller control model)**

Moving the tiller handle sideways to adjust the steering direction.

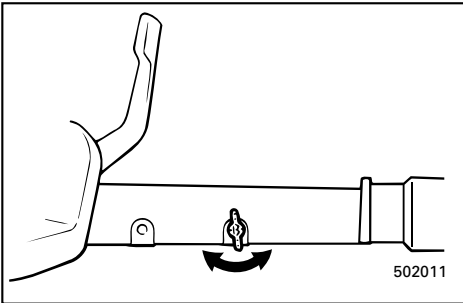

EMC64010

**Throttle Friction Adjustment
(for Tiller control model)**

A friction device in the tiller handle provides resistance to movement of the throttle grip. This is adjustable for operator preference. An adjusting screw/bolt is located within the tiller handle.

To increase the resistance:

Turn the adjusting screw/bolt clockwise.

To decrease the resistance:

Turn the adjusting screw/bolt counter-clockwise.

When constant speed is desired, tighten the adjusting screw/bolt to maintain the desired throttle setting.

⚠ WARNING

Do not overtighten the friction adjusting screw/bolt. If there is too much resistance, it may be difficult to move the throttle grip, which could result in an accident.

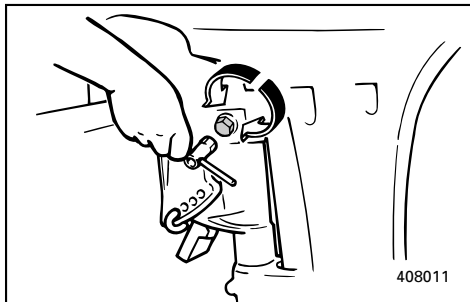

EMD00010

STEERING FRICTION ADJUSTMENT (for Tiller control model)

A friction device provides resistance to steering movement. This is adjustable for operator preference.

An adjusting screw/bolt is located on the swivel bracket.

To increase the resistance:
Turn the adjusting screw/bolt clockwise.

To decrease the resistance:
Turn the adjusting screw/bolt counter-clockwise.

⚠WARNING

Do not overtighten the friction screw/bolt. If there is too much resistance, it may be difficult to steer, which could result in an accident.

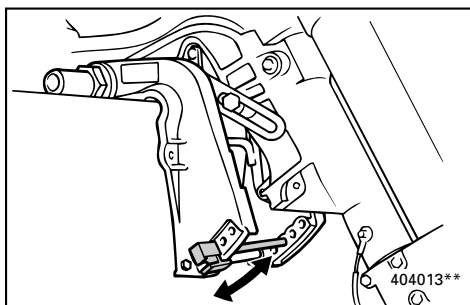

EMU01297

TRIM ANGLE ADJUSTING ROD

The position of the trim angle adjusting rod determines the minimum trim angle of the outboard motor in relation to the transom.

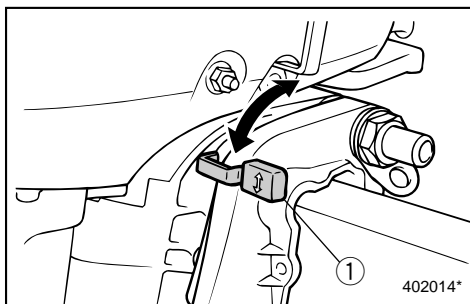

EMD44110

TILT LOCK MECHANISM (for Manual tilt model)

The tilt-lock mechanism is used to prevent reverse thrust from the propeller lifting the outboard motor when reversing. To lock it, set the tilt-lock lever in the Lock position. To release it, place the tilt-lock lever in the Tilt position.

① Tilt-lock lever

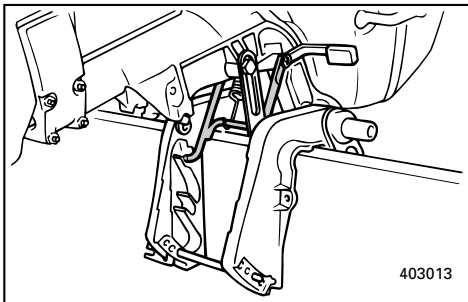

EMD48010

TILT SUPPORT BAR

The tilt support bar keeps the outboard motor in the tilted up position.

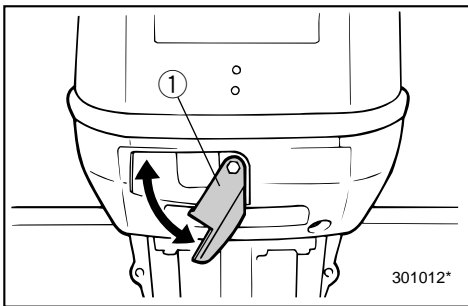

EMD62011

TOP COWLING LOCK LEVER

To remove the engine top cowling, turn the lock lever. Then lift off the cowling. When replacing the cowling, check to be sure it fits properly in the rubber seal. Then lock the cowling again by moving the lever upward.

- ① Top cowling lock lever

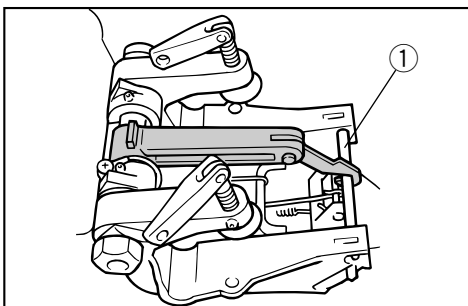

EMD68010*

CARRYING HANDLE

The carrying handle is included between the clamp bracket. The carrying handle enables you to carry the outboard motor readily with one hand after setting it up. To set up the carrying handle, proceed as follows.

- 1) Place the tilt lock lever in the lock position.
- 2) Securely hook the arm of carrying handle end to the clamp bracket bar.

CAUTION:

Place the tilt lock lever in the lock position while using the carrying handle. Otherwise, the lower casing may fall to the ground while carrying the motor.

- ① Clamp bracket bar

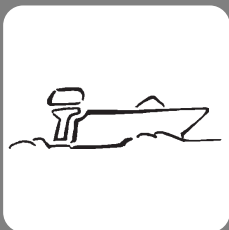

EMF00010

Chapter 3

OPERATION

INSTALLATION	3-1
Mounting the outboard motor	3-2
Clamping the outboard motor	3-4
FILLING FUEL AND ENGINE OIL	3-5
Filling fuel	3-5
Gasoline (petrol) and oil mixing	3-6
PRE-OPERATION CHECKS	3-7
BREAKING IN (RUNNING IN)	
ENGINE	3-8
STARTING ENGINE	3-10
WARMING UP ENGINE	3-13
SHIFTING	3-14
Forward	3-14
Reverse	3-15
STOPPING ENGINE	3-16
TRIMMING OUTBOARD MOTOR	3-17
Adjusting trim angle	3-18
CRUISING IN SHALLOW WATER	3-20
TILTING UP/DOWN	3-22
CRUISING IN OTHER CONDITIONS	3-24
Cruising in salt water	3-24
Cruising in turbid water	3-24



EMF10010

INSTALLATION

CAUTION: _____

Incorrect engine height or obstructions to smooth water flow (such as the design or condition of the boat or accessories such as transom ladders/depth finder transducers) can create airborne water spray while the boat is cruising. Severe engine damage may result if the motor is operated continuously in the presence of airborne water spray.

NOTE: _____

During water testing check the buoyancy of the boat, at rest, with its maximum load. Check that the static water level on the exhaust housing is low enough to prevent water entry into the powerhead, when water rises due to waves when the outboard is not running.



EMU00176

MOUNTING THE OUTBOARD MOTOR

⚠ WARNING

Improper mounting of the outboard motor could result in hazardous conditions such as poor handling, loss of control, or fire hazards. Observe the following:

- The information presented in this section is intended as reference only. It is not possible to provide complete instructions for every possible boat/motor combination. Proper mounting depends in part on experience and the specific boat/motor combination.
- Your dealer or other person experienced in proper rigging should mount the motor. If you are mounting the motor yourself, you should be trained by an experienced person. [permanent mounted type]
- Your dealer or other person experienced in proper outboard motor mounting should show you how to mount your motor. [portable type]

Mount the outboard motor on the center line (keel line) of the boat, and ensure that the boat itself is well balanced. Otherwise, the boat will be hard to steer. For boats without a keel or which are asymmetrical, consult your dealer.

- ① Center line (keel line)

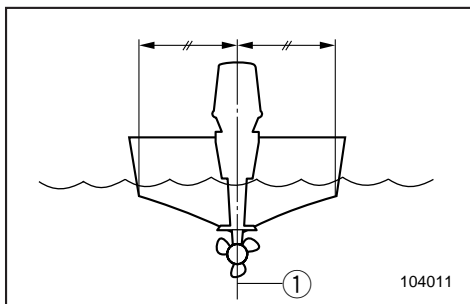

**⚠WARNING**

Overpowering a boat may cause severe instability. Do not install an outboard motor with more horsepower than the maximum rating on the capacity plate of the boat. If the boat does not have a capacity plate, consult the boat manufacturer.

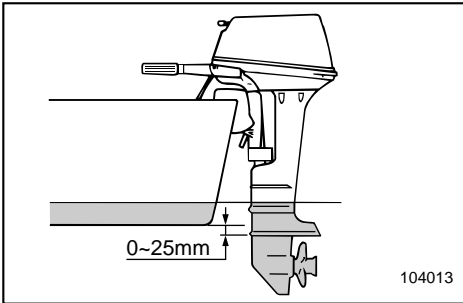

EMU01298

Mounting Height

To run your boat at optimum efficiency, the water-resistance (drag) of the boat and outboard motor must be made as little as possible. The mounting-height of the outboard motor greatly affects the water-resistance. If the mounting-height is too high, cavitation tends to occur, thus reducing the propulsion; and if the propeller tips cut the air, the engine speed will rise abnormally and cause the engine to overheat. If the mounting-height is too low, the water-resistance will increase and thereby reduce engine efficiency. Mount the engine so that the anti-cavitation plate is between the bottom of the boat and a level 25 mm (1 in.) below it.

NOTE:

- The optimum mounting height of the outboard motor is affected by the boat/motor combination and the desired use. Test runs at different heights can help determine the optimum mounting height.
- Refer to the section "TRIMMING OUTBOARD MOTOR" for instructions on setting the trim angle of the outboard.

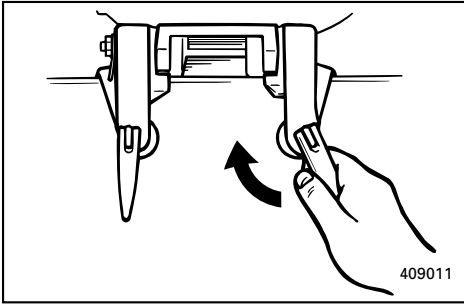

EMF14010

CLAMPING THE OUTBOARD MOTOR

- 1) Place the outboard on the transom so that it is positioned as close to the center as possible. Tighten the transom clamp screws evenly and securely. Check the clamp-screws for tightness occasionally during operation of the motor as they can work loose due to engine vibration.

⚠WARNING

Loose clamp screws could allow the motor to move on the transom or fall off the transom. This could cause loss of control and serious injury. Make sure the transom screws are tightened securely. Occasionally check the screws for tightness during operation.

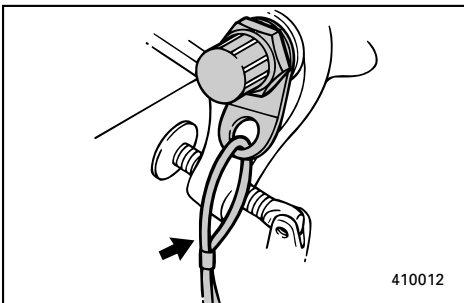

- 2) An engine restraint cable or chain should be used. Attach one end to the engine restraint cable attachment point and the other to a secure mounting point on the boat. Otherwise, the engine could be completely lost if it accidentally falls off the transom.



FILLING FUEL AND ENGINE OIL

EMF30010

FILLING FUEL

- 1) Remove the fuel tank cap.
 - 2) Fill the fuel tank carefully.
 - 3) Close the cap securely after refueling.
- Wipe up any spilled fuel.

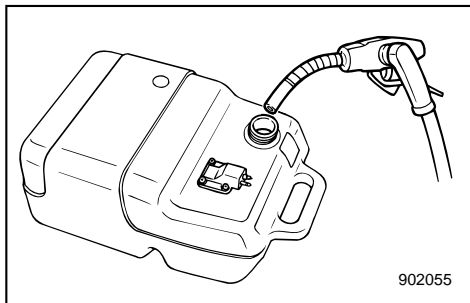

902055

Fuel tank capacity:
Refer to SPECIFICATIONS, Page 4-1.

Ring Free Fuel Additive

Gasoline is a precise blend of many different substances, each chosen to give certain characteristics. Gasoline blends have been changing in recent years in response to concerns about pollution and resulting emissions regulations. One of the most obvious changes has been the elimination of lead from most fuels.

As gasoline has changed, the amount of additives such as aromatics and oxygenates has increased. These additives are important for the engines in passenger cars, but they can have detrimental effects in marine engines, because of increased deposits in the combustion chamber. When enough deposits collect, piston rings begin sticking. Performance drops and engine wear increases dramatically.

While many additives available may reduce deposits, Yamaha recommends the use of **Ring Free Fuel Additive**, available from your Yamaha dealer. Ring Free has repeatedly proven its ability to clean combustion deposits from inside the engine, notably the critical piston-ring-land area, and fuel system components. Follow product labeling for use instructions.

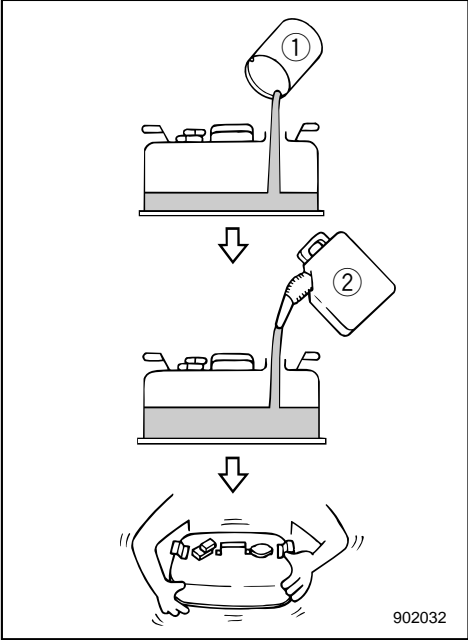

EMF35010

GASOLINE (PETROL) AND OIL MIXING

Pre-mix model

	Oil : Gasoline (Petrol)
Break-in period	1 : 25
After break-in	1 : 100

1) Pour oil and gasoline into the fuel tank, in that order.

- ① Oil
- ② Gasoline (Petrol)

- 2) Then mix the fuel thoroughly by shaking.
- 3) Make sure the oil is mixed with gasoline.

CAUTION:

- Avoid using any oil other than the designated type.
- Use a thoroughly blended fuel-oil mixture.
- If the mixture is not thoroughly blended, or if the mixing ratio is incorrect, the following problems could occur:

Low oil ratio:

Lack of oil could cause major engine trouble, such as piston seizure.

High oil ratio:

Too much oil could cause fouled spark plugs, smoky exhaust, and heavy carbon deposits.

Mixing ratio	25 : 1			
Gasoline (Petrol)	1 L (0.26 US gal, 0.22 Imp gal)	12 L (3.2 US gal, 2.6 Imp gal)	14 L (3.7 US gal, 3.1 Imp gal)	24 L (6.3 US gal, 5.3 Imp gal)
Engine oil	0.04 L (0.04 US qt, 0.04 Imp qt)	0.48 L (0.51 US qt, 0.42 Imp qt)	0.56 L (0.59 US qt, 0.49 Imp qt)	0.96 L (1.01 US qt, 0.84 Imp qt)



Mixing ratio	100 : 1			
Gasoline (Petrol)	1 L (0.26 US gal, 0.22 Imp gal)	12 L (3.2 US gal, 2.6 Imp gal)	14 L (3.7 US gal, 3.1 Imp gal)	24 L (6.3 US gal, 5.3 Imp gal)
Engine oil	0.01 L (0.01 US qt, 0.01 Imp qt)	0.12 L (0.13 US qt, 0.11 Imp qt)	0.14 L (0.15 US qt, 0.12 Imp qt)	0.24 L (0.25 US qt, 0.21 Imp qt)

NOTE: _____

If using a permanently installed tank, pour the oil gradually as the fuel is being added to the tank.

EMF40012

PRE-OPERATION CHECKS

⚠ WARNING _____

If any item in the pre-operation check is not working properly, have it inspected and repaired before operating the outboard motor. Otherwise, an accident could occur.

EMF41110

Fuel

- Check to be sure you have plenty of fuel for your trip.
- Make sure there are no fuel leaks or gasoline fumes.
- Check fuel line connections to be sure they are tight.
- Be sure the fuel tank is positioned on a secure, flat surface, and that the fuel hose is not twisted or flattened, or likely to contact sharp objects.

EMF42110

Oil

- Check to be sure you have plenty of oil for your trip.



EMF43010

Controls

- Check throttle, shift, and steering for proper operation before starting the engine.
- The controls should work smoothly, without binding or unusual free play.
- Look for loose or damaged connections.
- Check operation of the starter and stop switches when the outboard motor is in the water.

EMF43510

Engine

- Check the engine and engine mounting.
- Look for loose or damaged fasteners.
- Check the propeller for damage.

CAUTION: _____

Do not start the engine out of water. Overheating and serious engine damage can occur.

EMF50012

**BREAKING IN (RUNNING IN)
ENGINE**

Your new engine requires a period of break-in (running-in) to allow mating surfaces of moving parts to wear-in evenly. Correct break-in (running-in) will help ensure proper performance and longer engine life.

CAUTION: _____

Failure to follow the break-in (running-in) procedure may result in reduced engine life or even severe engine damage.



Break-in (running-in) time:10 hours

Break-in (running-in) premix ratio:
Refer to "Gasoline/Petrol and Oil
Mixing".

EMU00226

Run the engine under load (in gear with a propeller installed) as follows.

- 1) First 10 minutes:
Run the engine at the lowest possible-speed. A fast idle in neutral is best.
- 2) Next 50 minutes:
Do not exceed half throttle (approximately 3,000 r/min). Vary engine speed occasionally. If you have an easy-planing boat, accelerate at full throttle onto plane, then immediately reduce the throttle to 3,000 r/min or less.
- 3) Second hour:
Accelerate at full throttle onto plane, then reduce engine speed to three-quarter throttle (approximately 4,000 r/min). Vary engine speed occasionally. Run at full throttle for one minute, then allow about 10 minutes of operation at three-quarter throttle or less to let the engine cool.
- 4) Third through tenth hours:
Avoid operating at full throttle for more than 5 minutes at a time. Let the engine cool between full-throttle runs. Vary engine speed occasionally.
- 5) After the first 10 hours:
Operate the engine normally. Use the standard premix ratio of gasoline : Oil. (Refer to "Gasoline/Petrol and Oil Mixing".)



EMU01147

STARTING ENGINE

⚠WARNING

- Before starting the engine, make sure that the boat is tightly moored and that you can steer clear of any obstructions. Be sure there are no swimmers in the water near you.
- When the air vent screw is loosened, gasoline (petrol) vapor will be released. Gasoline (petrol) is highly flammable, and its vapors are flammable and explosive. Refrain from smoking, and keep away from open flames and sparks while loosening the air vent screw.
- This product emits exhaust gases which contain carbon monoxide, a colorless, odorless gas which may cause brain damage or death when inhaled. Symptoms include nausea, dizziness, and drowsiness. Keep cockpit and cabin areas well ventilated. Avoid blocking exhaust outlets.

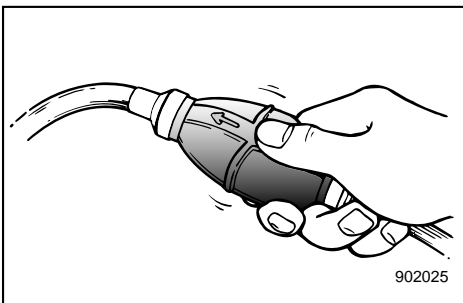
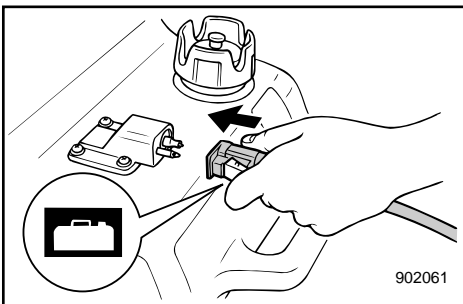
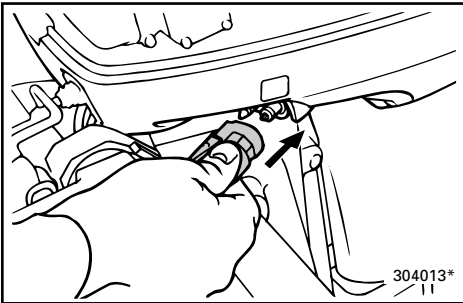
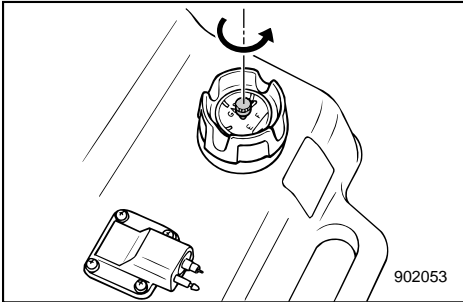

- 1) If there is an air vent screw on the fuel tank cap, loosen it 2 or 3 turns.
- 2) If there is a fuel joint on the motor, firmly connect the fuel line to the joint. Then firmly connect the other end of the fuel line to the joint on the fuel tank.

NOTE:

During engine operation place the tank horizontally, or fuel cannot be drawn into the engine.

- 3) Squeeze the primer bulb with the outlet end up until you feel it become firm.

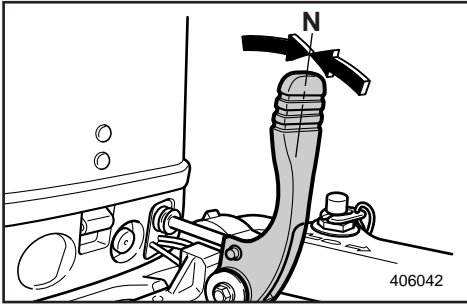

EMU00854

PROCEDURE FOR TILLER CONTROL MODEL

- 4) Place the gear-shift lever in the neutral position.

NOTE: _____

The start-in-gear protection device prevents the engine from starting except when in Neutral.

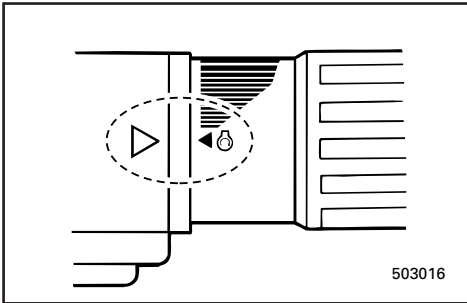

- 5) Place the throttle control grip in the "START" position.

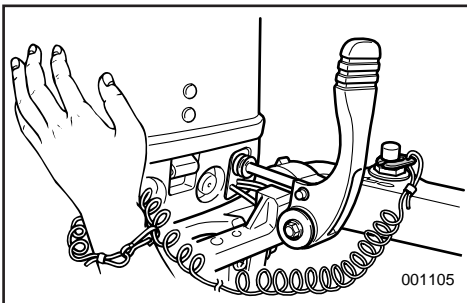

- 6) Attach the engine stop switch lanyard to a secure place on your clothing, or your arm or leg. Then, install the lock plate on the other end of the lanyard in the engine stop switch.

WARNING _____

- Attach the engine stop switch lanyard to a secure place on your clothing, your arm or leg while operating.
 - Do not attach the lanyard to clothing that could tear loose. Do not route the lanyard where it could become entangled, preventing it from functioning.
 - Avoid accidentally pulling the lanyard during normal operation. Loss of engine power means the loss of most steering control. Also, without engine power, the boat could slow rapidly. This could cause people and objects in the boat to be thrown forward.
- _____

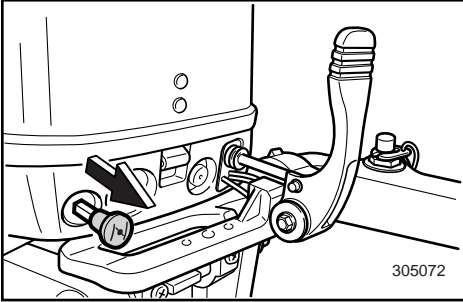

EMU00241*

Manual Start Model

- 7) Pull out the choke knob completely when the engine is cold. After the engine starts, set the choke knob to the 2nd or 3rd position for warming up the cold engine. After warming up the engine, set the choke knob to the original position.

NOTE:

- It is not necessary to use the choke when restarting a hot engine.
- If the choke knob is left pulled out, the engine will stall.

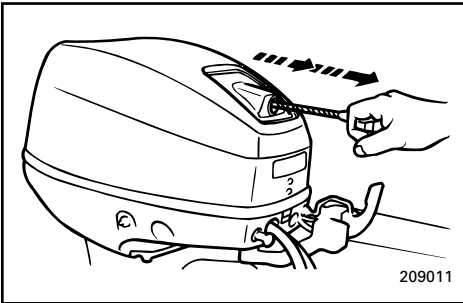

- 8) Pull the starter handle slowly until you feel resistance. Then, give a strong pull straight out to start the engine. Repeat it, if necessary.
- 9) After the engine starts, return the starter handle slowly to the original position before releasing it.



EMG00010-*

WARMING UP ENGINE

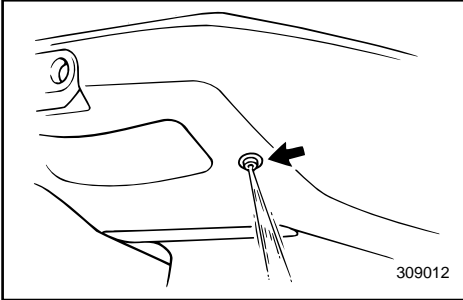

- 1) Before beginning operation, allow the engine to warm up at idling speed for 3 minutes. (Failure to do this will shorten engine life.)
- 2) Check for a steady flow of water from the cooling-water pilot hole.

CAUTION:

A continuous flow of water from the pilot hole shows that the water pump is pumping water through the cooling passages. If water is not flowing out of the pilot hole at all times while the engine is running, do not continue to run the engine. Overheating and serious damage could occur. Stop the engine and check to see if the water inlet on the lower casing is blocked. If the problem cannot be found and corrected, consult your Yamaha dealer.



EMG20111

SHIFTING

⚠ WARNING

Before shifting, make sure there are no swimmers or obstacles in the water near you.

CAUTION:

To change the shifting position from forward to reverse or vice-versa, close the throttle first so that the engine idles (or runs at low speeds).

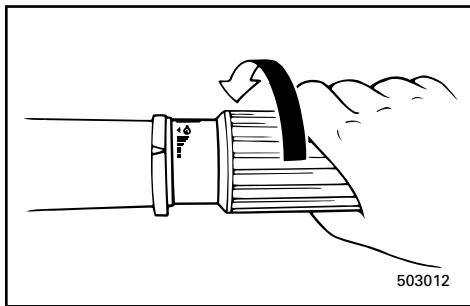

EMG22110

FORWARD

- 1) Place the throttle control grip in the fully closed position.
- 2) Turn the gear shift lever quickly and firmly from Neutral to Forward.

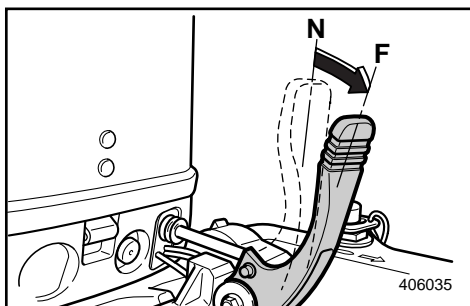



EMG33210

REVERSE

⚠WARNING

When operating in Reverse, go slowly. Do not open the throttle more than half. Otherwise, the boat may become unstable, which could result in loss of control and an accident.

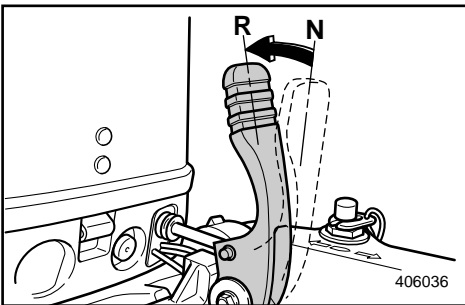
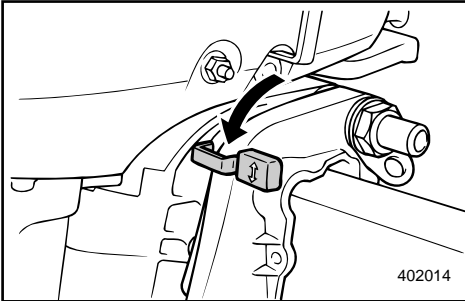
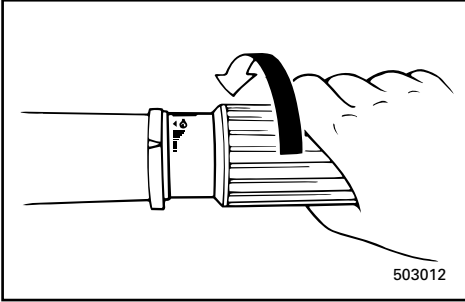

- 1) Place the throttle control grip in the fully closed position (for Tiller control model).
- 2) Check that the tilt-lock lever (for Manual tilt model) is in the locked position.
- 3) Turn the gear-shift lever quickly and firmly from Neutral to Reverse.



EMG38010

STOPPING ENGINE

Let it cool off for a few minutes at idle or low speed first. Stopping the engine immediately after operating at high speed is not recommended.

EMU00275

- 1) Push and hold the engine stop button until the engine comes to a complete stop.
- 2) After stopping the engine, disconnect the fuel line from the motor.

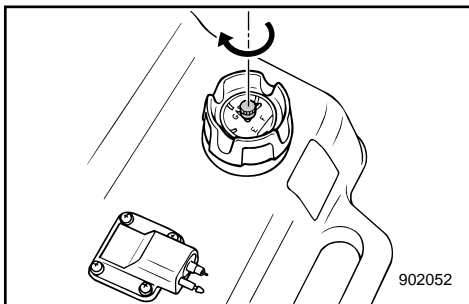
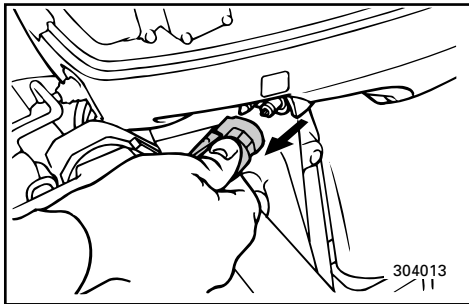
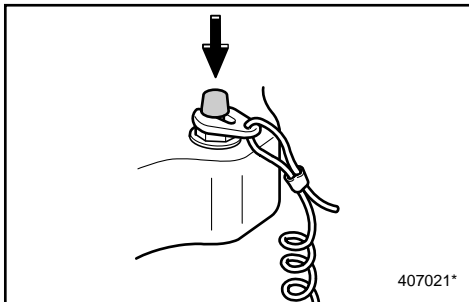

- 3) Tighten the air vent screw on the fuel tank cap after stopping the engine, if it is equipped.

NOTE: _____

The engine can also be stopped by pulling the lanyard and removing the lock plate from the engine stop lanyard switch.



EMU01412

TRIMMING OUTBOARD MOTOR

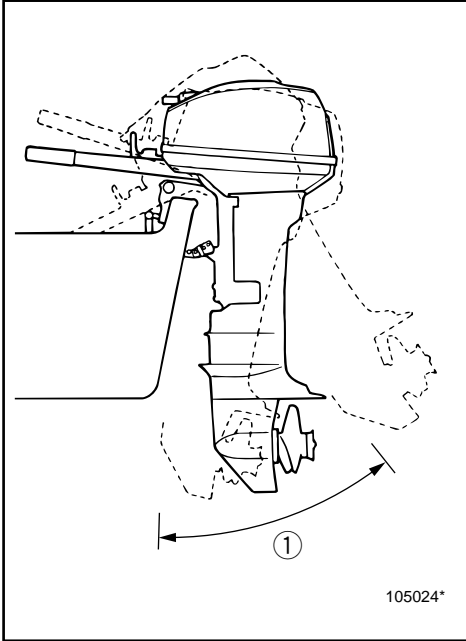

The trim angle of the outboard motor helps determine the position of the bow of the boat in the water. The correct trim angle will help improve performance and fuel economy while reducing strain on the engine. The correct trim angle depends upon the combination of boat, engine, and propeller. Correct trim is also affected by variables such as the load in the boat, sea conditions, and running speed.

⚠WARNING

Excessive trim for the operating conditions (either trim up or trim down) can cause boat instability and can make steering the boat more difficult. This increases the possibility of an accident. If the boat begins to feel unstable or is hard to steer, slow down and/or readjust the trim angle.

NOTE:

Refer to the section "ADJUSTING TRIM ANGLE" for instructions on usage.

① Trim operating angle

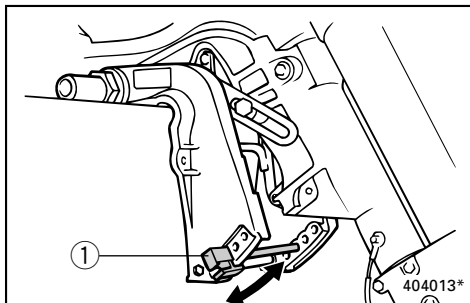

ADJUSTING TRIM ANGLE

EMU00951

Manual tilt model

There are 4 or 5 holes provided in the clamp bracket to adjust the outboard motor trim angle.

- 1) Stop the engine.
- 2) Remove the trim angle adjusting rod ① from the clamp bracket while tilting the motor up slightly.
- 3) Reposition the rod in the desired hole. To raise the bow ("trim-out"), move the rod away from the transom. To lower the bow ("trim-in"), move the rod toward the transom.

Make test runs with the trim set to different angles to find the position that works best for your boat and operating conditions.

⚠WARNING

- Stop the engine before adjusting the trim angle.
- Use care to avoid being pinched when removing or installing the rod.
- Use caution when trying a trim position for the first time. Increase speed gradually and watch for any signs of instability or control problems. Improper trim angle can cause loss of control.

NOTE:

The outboard motor trim angle can be changed approximately 4 degrees by shifting the trim adjusting-rod one hole.



EMG62010

Bow up

When the boat is on plane, a bow-up attitude result in less drag, greater stability and efficiency. This is generally when the keel line of the boat is up about 3 to 5 degrees. When trimmed out, the boat may have more tendency to steer to one side or the other. Compensate for this as you steer. The trim tab can also be adjusted to help offset this effect.

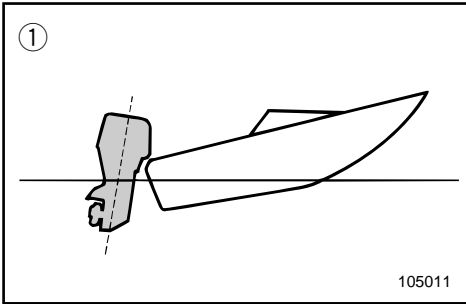

Too much trim-out puts the bow of the boat too high in the water. Performance and economy are decreased because the hull of the boat is pushing the water and there is more air drag.

Excessive trim-up can cause the propeller to ventilate, which reduces performance further. When trimmed-out too much, a boat may “porpoise” (hop in the water), which could throw the operator and passengers overboard.

EMG62110

Bow down

When the bow of the boat is down, it is easier to accelerate from a standing start onto plane.

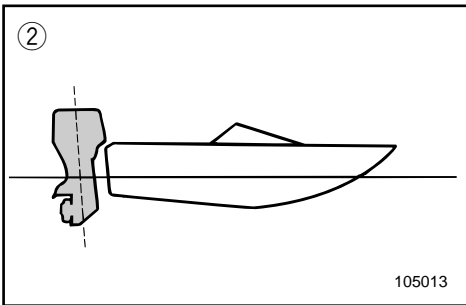

Too much trim-in causes the boat to “plow” through the water, decreasing fuel economy and making in hard to increase speed.

Operating with excessive trim-in at higher speeds also makes the boat unstable. Resistance at the bow is greatly increased, heightening the danger of “bow steering” and making operation difficult and dangerous.

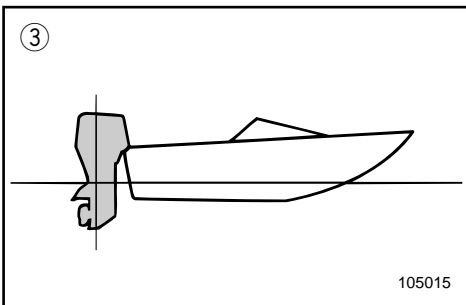

- ① Bow up
- ② Bow down
- ③ Optimum angle



EMG70011

CRUISING IN SHALLOW WATER

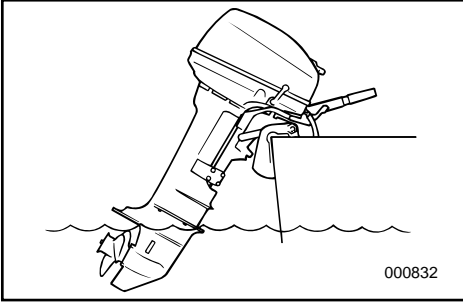

The outboard motor can be tilted up partially to allow operation in shallow water.

⚠ WARNING

- Place the gear shift in the Neutral position before using the shallow water cruising system.
- Run the boat at the lowest possible speed when using the shallow water cruising system. The tilt-lock mechanism does not work while the shallow water cruising system is being used. Hitting an underwater obstacle could cause the engine to lift out of the water, resulting in loss of control.
- Use extra care when operating in reverse. Too much reverse thrust can cause the engine to lift out of the water, increasing the chance of accident and personal injury.
- Return the engine to its normal position as soon as the boat is back in deeper water.

CAUTION:

Place the gear-shift in the Neutral position before using the shallow water cruising system.

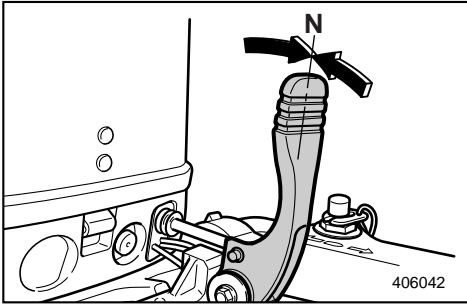

EMG71210

PROCEDURE

- 1) Place the gear shift lever in the neutral position.

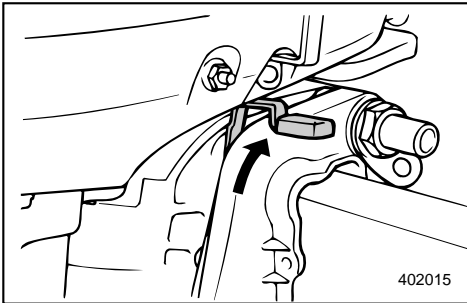

- 2) Pull up the tilt lock lever.

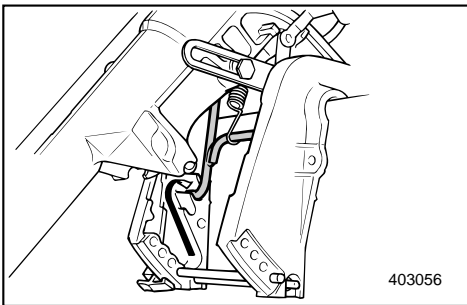

- 3) Slightly tilt up the engine. The tilt-support bar will lock automatically, supporting the engine in a partially raised position.

NOTE: _____
If the engine is tilted up completely, the tilt-lock lever automatically locks. The shallow water lever is no longer effective.

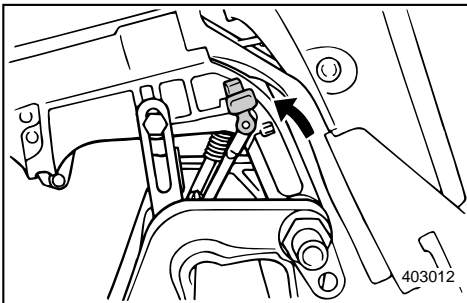

- 4) When lowering the engine, push the tilt lock lever down. Slightly tilt up the engine until the tilt-support bar automatically returns to the free position. Then, slowly lower the engine to the normal position.



EMH10110

TILTING UP/DOWN

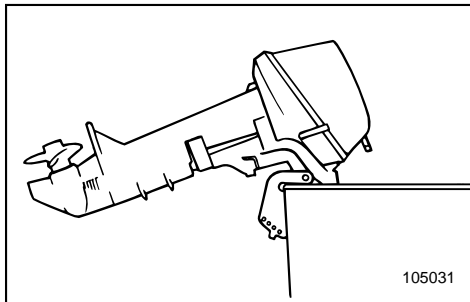

If the engine will be stopped for some time, or if the boat is moored in shallows, the engine should be tilted up to protect the propeller and casing from damage by collision with obstructions, and also to reduce salt corrosion.

CAUTION:

- Before tilting the motor, follow the procedures under "STOPPING ENGINE". Never tilt the motor while the engine is running. Severe damage from overheating can result.
- Do not tilt up the engine by pushing the steering handle as this could break the handle.
- Keep the power unit higher than the propeller at all times. Otherwise, water can run into the cylinder, causing damage.

⚠ WARNING

Be sure all people are clear of the outboard motor when adjusting the tilt angle, also be careful not to pinch any body parts between the drive unit and engine bracket.

⚠ WARNING

Leaking fuel is a fire hazard. Disconnect the fuel line if the engine will be tilted for more than a few minutes. Otherwise, fuel may leak. (If the fuel connector is provided on the motor.)



EMU00290

PROCEDURE FOR TILTING UP

- 1) Place the gear shift lever in Neutral.
- 2) Remove the fuel line connection from the motor.

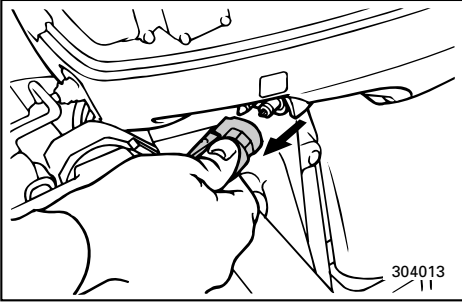

- 3) Place the tilt lock lever in the release position.

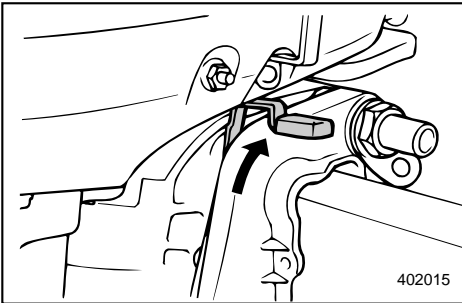

- 4) Hold the rear of the top cowling with one hand and fully tilt the engine up.
- 5) The tilt support bar turns to the locked position automatically.

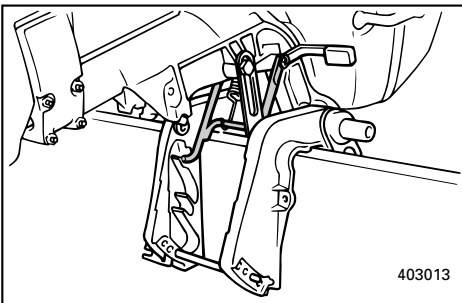

EMU00300

PROCEDURE FOR TILTING DOWN

- 1) Place the tilt lock lever in the lock position.
- 2) Slightly tilt up the engine until the tilt support bar is released automatically.
- 3) Tilt down the engine.

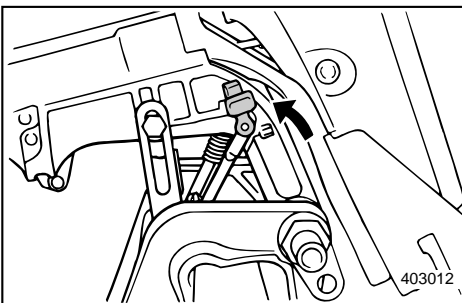



EMH60010

CRUISING IN OTHER CONDITIONS

CRUISING IN SALT WATER

After operating in salt water, wash out the cooling-water passages with fresh water to prevent them from becoming clogged-up with salt deposits.

NOTE: _____

Refer to cooling system flushing instructions in "TRANSPORTING AND STORING OUTBOARD MOTOR".

CRUISING IN TURBID WATER

It is strongly recommended that the optional chromium-plated water-pump kit be installed if the outboard is to be used in turbid (muddy) water conditions.



-MEMO-

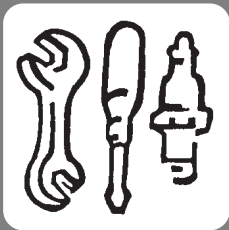

EMK00010

Chapter 4

MAINTENANCE

SPECIFICATION DATA.....4-1

TRANSPORTING AND STORING

OUTBOARD MOTOR4-3

Trailing outboard motor.....4-3

Storing outboard motor4-4

PERIODIC MAINTENANCE.....4-7

Replacement parts4-7

Maintenance chart.....4-8

Cleaning and adjusting spark plug.....4-9

Checking fuel system4-11

Inspecting fuel filter4-12

Adjusting idling speed.....4-13

Checking wiring and connectors4-14

Exhaust leakage.....4-14

Water leakage4-14

Greasing4-15

Checking propeller4-16

Changing gear oil4-18

Cleaning fuel tank.....4-19

Inspecting and replacing anode4-20

Checking bolts and nuts4-21

Motor exterior.....4-21

Coating the boat bottom4-21

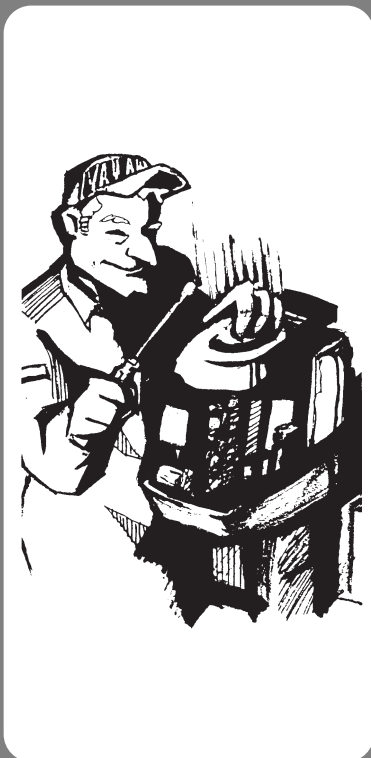



EMR50302*

SPECIFICATION DATA

Item	Model	Unit	9.9MHA
DIMENSIONS			
●Overall Length		mm (in.)	873 (34.4)
●Overall Height	S	mm (in.)	1,040 (40.9)
●Overall Width		mm (in.)	332 (13.1)
●Transom height	S	mm (in.)	440 (17.3)
●Weight	S	kg (lb.)	36.6 (79.4)
PERFORMANCE			
●Full throttle operating range		r/min	4,500-5,500
●Maximum output		kW (HP)	7.3 (9.9) at 5,000 r/min.
●Idling speed (in neutral)		r/min	700~800
ENGINE			
●Engine type			2-stroke, L2
Displacement		cm ³ (cu.in.)	246 (15.01)
Bore × stroke		mm (in.)	56 × 50 (2.20 × 1.97)
●Ignition system			C.D.I
●Spark plug		NGK	B7HS-10
Spark plug gap		mm (in.)	0.9~1.0 (0.035~0.039)
●Control system			Tiller control
●Starting system			Manual start
●Battery capacity		V-AH (kc)	—
Minimum cold crank performance		Amps at -17.8°C (0°F)	—
Minimum reserve capacity		minutes at 26.7°C (80°F)	—
●Alternator output		V-A (W)	12-(80)
●Starting carburetion system			Choke valve start system
DRIVE UNIT			
●Gear positions			Forward-Neutral-Reverse
Gear ratio			2.08 (27/13)
●Trim/tilt system			Manual
●Propeller mark			J
FUEL AND OIL			
●Fuel			Regular unleaded gasoline (P.O.N.: minimum 86)
Fuel tank capacity		L (US gal, Imp gal)	25 (6.6, 5.5)
●Recommended engine oil			YAMALUBE, 2 STROKE OUTBOARD OIL or an equivalent TC-W3 certified outboard oil
Fuel/oil ratio			100 : 1
●Recommended gear oil			Hypoid gear oil (SAE 90)
Gear oil quantity		cm ³ (US oz, Imp oz)	250 (8.5, 8.8)
TIGHTENING TORQUE			
●Spark plug		N•m (kgf•m, lb•ft)	25 (2.5, 18)
●Propeller nut		N•m (kgf•m, lb•ft)	17 (1.7, 12)



15MHA	—	—
873 (34.4) 1,040 (40.9) 332 (13.1) 440 (17.3) 36.6 (79.4)		
4,500~5,500 11.0 (15) at 5,000 r/min. 700~800		
2-stroke, L2 246 (15.01) 56 × 50 (2.20 × 1.97) C.D.I B7HS-10 0.9~1.0 (0.035~0.039) Tiller control Manual start — — — 12-(80) Choke valve start system		
Forward-Neutral-Reverse 2.08 (27/13) Manual J		
Regular unleaded gasoline (P.O.N.: minimum 86) 25 (6.6, 5.5) YAMALUBE, 2 STROKE OUTBOARD OIL or an equivalent TC-W3 certified outboard oil 100 : 1 Hypoid gear oil (SAE 90) 250 (8.5, 8.8)		
25 (2.5, 18) 17 (1.7, 12)		



EMU01369

TRANSPORTING AND STORING OUTBOARD MOTOR

⚠ WARNING

Leaking fuel is a fire hazard. When transporting and storing the outboard motor, close the air vent screw and fuel cock to prevent fuel from leaking.

TRAILERING OUTBOARD MOTOR

The motor should be trailered and stored in the normal running position. If there is insufficient road clearance in this position, then trailer the motor in the tilt position using a motor support device such as a transom saver bar.

CAUTION:

Do not use the tilt support lever/knob when trailering the boat. The outboard motor could shake loose from the tilt support and fall. If the motor can not be trailered in the down position, use an additional support device to secure it in the up position.

⚠ WARNING

- Never get under the lower unit while it is tilted, even if a motor support bar is used. Severe injury could occur if the outboard accidentally falls.
- USE CARE when transporting fuel tank, whether in a boat or car.
DO NOT fill fuel container to maximum capacity.
Gasoline will expand considerably as it warms up and can build up pressure in the fuel container. This can cause fuel leakage and a potential fire hazard.

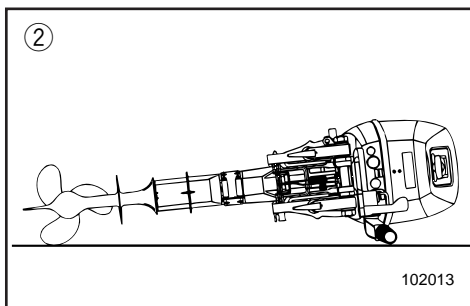
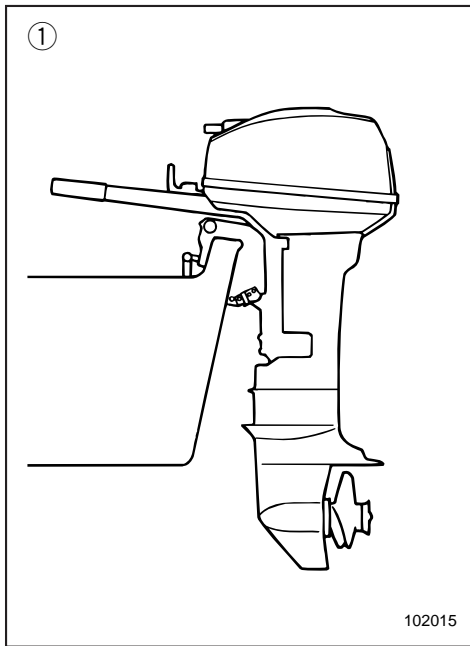

When transporting or storing the outboard motor while removed from a boat, fold the tiller handle and lean the motor on the tiller handle to keep in a horizontal position.

- ① Vertical position
- ② Horizontal position

NOTE: _____

Place a towel or the like under the outboard motor to protect it from damage.

CAUTION: _____

Keep the power unit higher than the propeller at all times.

Otherwise, cooling water can run into the cylinder, which could result in damage.

EMK22010**

STORING OUTBOARD MOTOR

When storing your Yamaha outboard for prolonged periods of time, (2 months or longer), several important procedures must be performed to prevent expensive damage.

It is advisable to have your outboard serviced by an authorized Yamaha dealer prior to storage. However, the following procedures can be performed by you, the owner, with a minimum of tools.

Filling Fuel Tank

Fill the fuel tank with fresh fuel and add one ounce of "Yamaha fuel conditioner and stabilizer" (Part No. LUB-FUELC-12-00) to each gallon of fuel.

NOTE: _____

The use of Yamaha Fuel Conditioner and Stabilizer eliminates the need to drain the fuel system. Consult your Yamaha dealer or other qualified mechanic if the fuel system is to be drained instead.



EMU00338*

Flushing Cooling System and Fogging Engine

Cooling system flushing is essential to prevent the cooling system from clogging up with salt, sand, or dirt. In addition, fogging of the engine is mandatory to prevent expensive engine damage due to rust. Perform the flushing and fogging at the same time.

⚠ WARNING

- Do not touch or remove electrical parts when starting or during operation.
- Keep hands, hair and clothes away from flywheel and other rotating parts while engine is running.

EMU00994*

• Flushing in a Water Tank

CAUTION:

If the fresh water level is below the level of the anti-cavitation plate, or if the water supply is insufficient, engine seizure may occur.

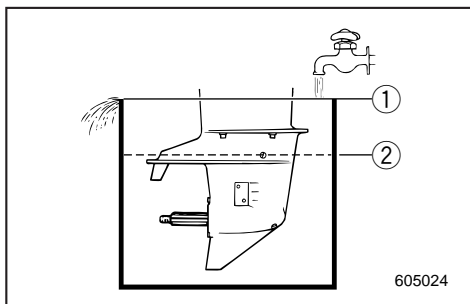
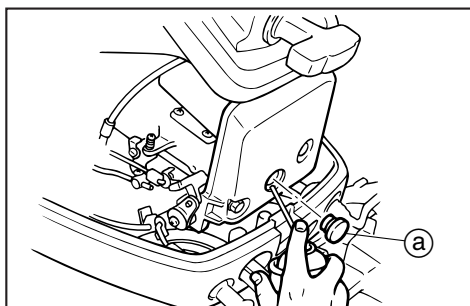

- 1) Remove the engine top cowling.
- 2) Install the outboard motor on the water tank.
- 3) Fill the tank with fresh water to above the level of the anti-cavitation plate.
- 4) Remove the cap a for fogging on the silencer cover.
- 5) Run the engine at a fast idle for 10~15 minutes.
- 6) Just prior to turning off the engine, quickly spray "Yamaha Stor-Rite Engine Fogging Oil" (Part No. LUB-STRRT-12-00) into the silencer cover. When properly done, the engine will smoke excessively and almost stall.
- 7) Remove the motor from the water tank.
- 8) Install the cap and the top cowling.

① Water surface ② Lowest water level



EMK26010

Lubrication

- 1) Remove the spark plugs, and spray a 10 second spray of Yamaha Stor-Rite Engine Fogging Oil into each cylinder. Grease the spark plug threads and reinstall the spark plugs and torque to proper specification.
(Refer to the Periodic Maintenance section, "Cleaning and adjusting spark plug.").
- 2) Turn the engine over with the stop lanyard disconnected to work the fogging oil into the piston rings.
- 3) Change the lower unit oil. (Refer to the Periodic Maintenance section, "Changing gear oil."). Inspect the oil for the presence of water which indicates a leaky seal. Seal replacement should be performed by an authorized Yamaha dealership prior to use.
- 4) Grease all grease fittings. (Refer to the Periodic Maintenance section, "Greasing.")

EMK27010

Cleaning and Anti-corrosion Measure

- 1) Wash down the exterior of the outboard with fresh water and dry off completely.
- 2) Spray the engine's exterior with Yamaha Silicone Protectant (Part No. LUB-SILCNE-13-00).
- 3) Wax the cowling with a non-abrasive wax such as Yamaha Silicone Wax (Part No. ACC-11000-15-02).



EMK32110

PERIODIC MAINTENANCE

⚠ WARNING

Be sure to turn off the engine when you perform maintenance unless otherwise specified. If the owner is not familiar with machine servicing, this work should be done by a Yamaha dealer or other qualified mechanic.

A service manual is available for purchase through a Yamaha dealer for owners who have the mechanical skills, tools, and other equipment necessary to perform maintenance not covered by this owner's manual.

EMK33011

REPLACEMENT PARTS

If replacement parts are necessary, use only genuine Yamaha parts or equivalents of the same type and of equivalent strength and materials. Any part of inferior quality may malfunction, and the resulting loss of control could endanger the operator and passengers.

Yamaha genuine parts and accessories are available from a Yamaha dealer.



MAINTENANCE CHART

Frequency of maintenance operations may be adjusted according to the operating conditions, but the following table gives general guidelines.

The mark (●) indicates the check-ups which you may carry out yourself.

The mark (○) indicates work to be carried out by your Yamaha dealer.

Item	Interval	Initial		Every		Refer Page
		10 hours	50 hours (3 months)	100 hours (6 months)	200 hours (1 year)	
Spark plug	Cleaning/Adjustment/ Replacement	●	●	●		4-9
Greasing points	Greasing			●		4-15
Gear oil	Change	●		●		4-18
Fuel system	Inspection			●		4-11
Fuel filter	Cleaning/Inspection	●	●	●		4-12
Fuel tank *1	Cleaning				●	4-19
Idling speed	Adjustment			●		4-13
Anode	Inspection/Replacement		○	○		4-20
Outboard motor exterior	Inspection		●	●		4-21
Cooling water passages	Cleaning		●	●		4-5
Propeller and cotter pin	Inspection/Replacement		●	●		4-16 4-17
Carburetor setting	Inspection/Adjustment	○		○		—
Ignition timing	Inspection/Adjustment	○		○		—
Bolts and nuts	Retightening	○		○		4-21

*1. If a portable fuel tank is equipped.

NOTE: _____

Cooling water passages;

When operating in salt water, turbid or muddy water, the engine should be flushed with clean water after each use.



EMU01202

CLEANING AND ADJUSTING SPARK PLUG

⚠ WARNING

When removing or installing a spark plug, be careful not to damage the insulator. A damaged insulator could allow external sparks, which could lead to explosion or fire.

The spark plug is an important engine component and is easy to inspect. The condition of the spark plug can indicate something about the condition of the engine. For example, if the center electrode porcelain is very white, this could indicate an intake air leak or carburetion problem in that cylinder. Do not attempt to diagnose any problems yourself. Instead, take the outboard motor to a Yamaha dealer. You should periodically remove and inspect the spark plug because heat and deposits will cause the spark plug to slowly break down and erode. If electrode erosion becomes excessive, or if carbon and other deposits are excessive, you should replace the spark plug with another of the correct type.

Standard spark plug:
Refer to "SPECIFICATIONS", page 4-1.

Before fitting the spark plug, measure the electrode gap with a wire thickness gauge; adjust the gap to specification if necessary.

Spark plug gap:
Refer to "SPECIFICATIONS", page 4-1.



When fitting the plug, always clean the gasket surface and use a new gasket. Wipe off any dirt from the threads and screw in the spark plug to the correct torque.

Spark plug torque:
Refer to "SPECIFICATIONS", page 4-1.

NOTE: _____

If a torque-wrench is not available when you are fitting a spark plug, a good estimate of the correct torque is 1/4 to 1/2 a turn past finger-tight. Have the spark plug adjusted to the correct torque as soon as possible with a torque-wrench.

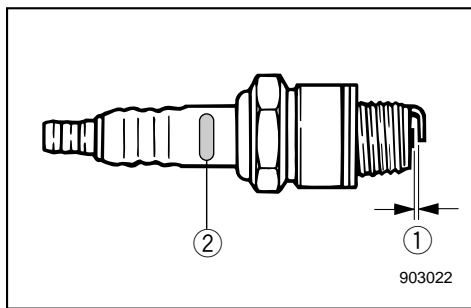

Initial of spark plug I.D. mark	Plug wrench size
B	21 mm (13/16 in.)
C/BK	16 mm (5/8 in.)
D	18.3 mm (23/32 in.)

- ① Spark plug gap
- ② Spark plug I.D. mark (NGK)

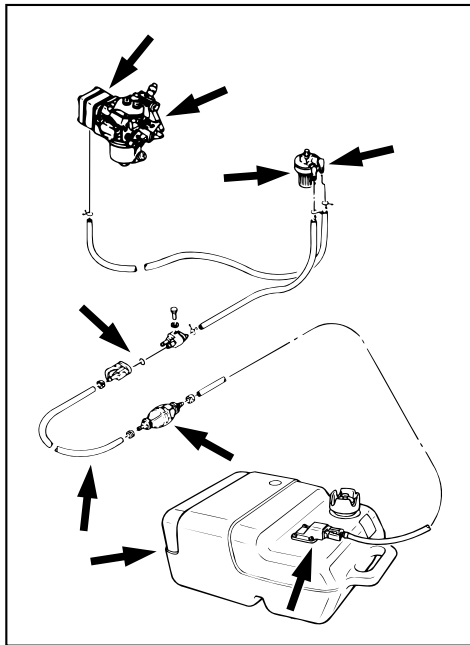

EMK38010

CHECKING FUEL SYSTEM

⚠WARNING

Gasoline (petrol) and its vapors are highly flammable and explosive. Keep away from sparks, cigarettes, flames or other sources of ignition.

Check the fuel line for leaks, cracks, or malfunctions. If any problem is found, it should be repaired immediately by Yamaha dealer or other qualified mechanic.

Checking points

- Fuel system parts leakage.
- Fuel hose joint leakage.
- Fuel hose cracks or other damage.
- Fuel connector leakage.

⚠WARNING

Leaking fuel can result in fire or explosion.

- Check for fuel leakage regularly.
- If any fuel leakage is found, the fuel system must be repaired by a qualified mechanic.

Improper repairs can make the outboard unsafe to operate.



EMU00370

INSPECTING FUEL FILTER

⚠WARNING

Gasoline (petrol) is highly flammable, and its vapors are flammable and explosive.

- If you have any question about properly doing this procedure, consult your Yamaha dealer.
- Do not perform this procedure on a hot or running engine. Allow the engine to cool.
- There will be fuel in the fuel filter. Keep away from sparks, cigarettes, flames or other sources of ignition.
- This procedure will allow some fuel to spill. Catch fuel in a rag. Wipe up any spilled fuel immediately.
- The fuel filter must be reassembled carefully with O-ring, filter cup, and hoses in place. Improper assembly or replacement can result in a fuel leak, which could result in a fire or explosion hazard.

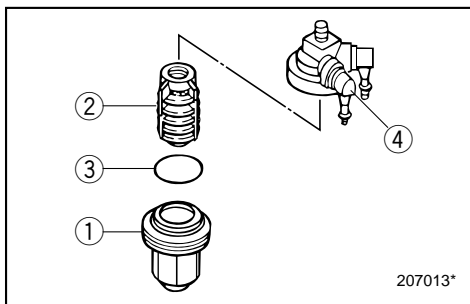
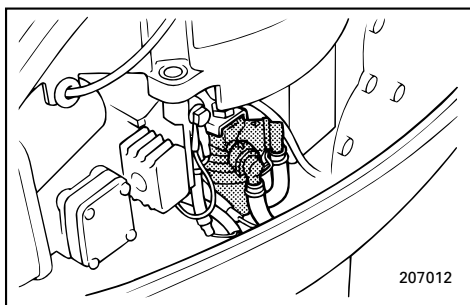

EMU00978*

- 1) Remove the nut holding the fuel filter assembly if equipped.
- 2) Unscrew the filter cup ①, catching any spilled fuel in a rag.
- 3) Remove the filter element ②, and wash it in solvent. Allow it to dry. Inspect the filter element and O-ring ③ to make sure they are in good condition. Replace them if necessary.
- 4) Reinstall the filter element in the cup. Make sure the O-ring is in position in the cup. Firmly screw the cup onto the filter housing ④.
- 5) Attach the filter assembly to the bracket with that the fuel hoses are attached to the filter assembly.
- 6) Run the engine and check the filter and lines for leaks.



EMU00991

ADJUSTING IDLING SPEED

⚠WARNING

- Do not touch or remove electrical parts when starting or during operation.
- Keep hands, hair and clothes away from flywheel and other rotating parts while engine is running.

CAUTION:

This procedure must be performed while the outboard motor is in the water. A flushing attachment or test tank can be used.

A diagnostic tachometer should be used for this procedure.

- 1) Start the engine and allow it to warm up fully in Neutral until it is running smoothly. If the outboard is mounted on a boat, be sure the boat is tightly moored.
- 2) Adjust the throttle stop-screw ① to set the idling speed to specification (see "SPECIFICATIONS" on page 4-1) by turning the stop-screw clockwise to increase the idling speed, and turning it counterclockwise to decrease the idling speed.

NOTE:

Correct idling-speed adjustment is only possible if the engine is fully warmed-up. If not warmed up fully, the speed setting will tend to be too high. If you have difficulty obtaining the specified idle, consult a Yamaha dealer or other qualified mechanic.

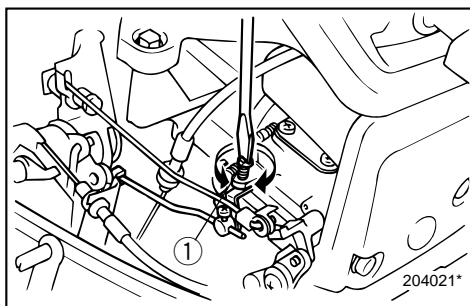

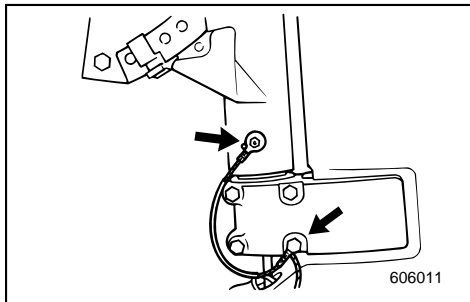

EMK78010

CHECKING WIRING AND CONNECTORS

- 1) Check that each grounding wire is properly secured.
- 2) Check that each connector is engaged securely.

EXHAUST LEAKAGE

Start the engine and check that no exhaust leaks from the joints between the exhaust cover, cylinder head and crank case.

WATER LEAKAGE

Start the engine and check that no water leaks from the joints between the exhaust cover, cylinder head and crank case.



EMU00366

GREASING

Yamaha marine grease
(Water resistant grease)

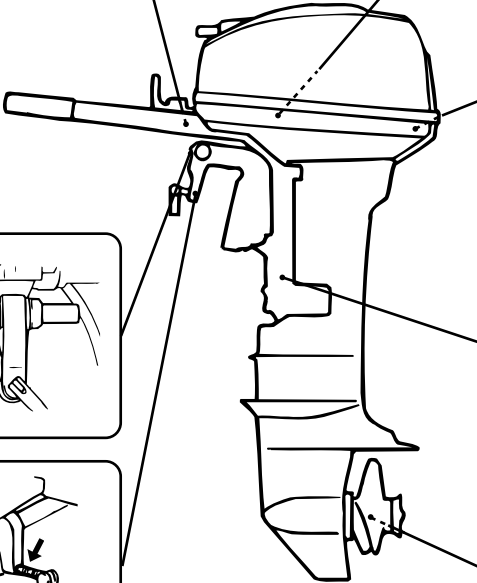
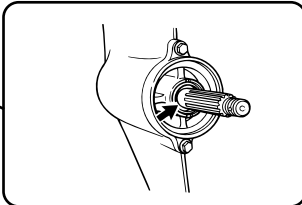
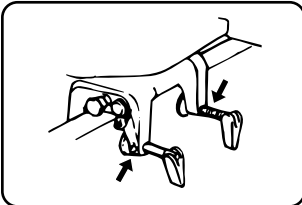
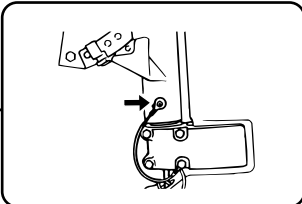
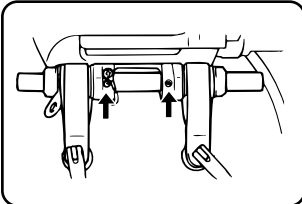
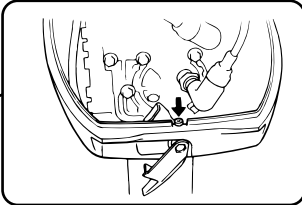
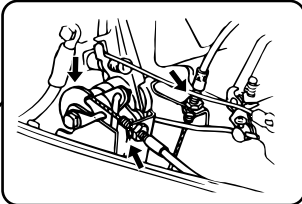
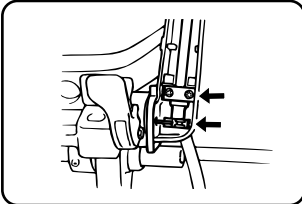

103011

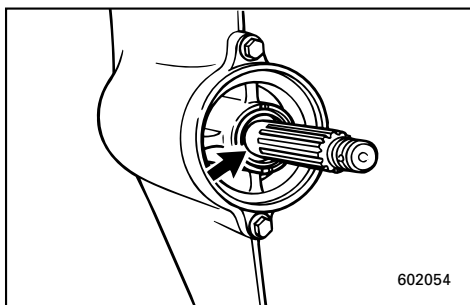
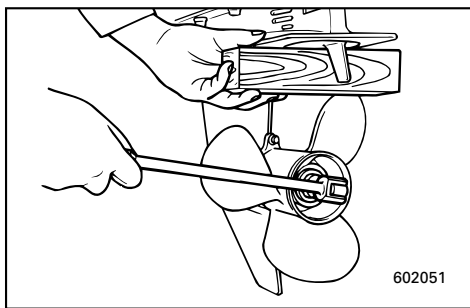
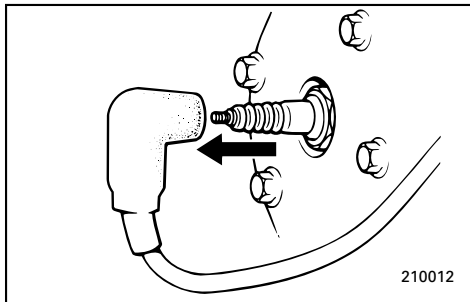

EML08110.*

CHECKING PROPELLER

⚠ WARNING

You could be seriously injured if the engine accidentally starts while you are near the propeller.

- Before inspecting, removing or installing the propeller, remove the spark plug caps from the spark plugs. Also, put the shift control in Neutral, put the main switch in the OFF position and remove the key, and remove the lanyard from the engine stop switch. Turn off the battery cut-off switch if your boat has one.
- Do not use your hand to hold the propeller when loosening or tightening the propeller nut. Put a wood block between the cavitation plate and the propeller to prevent the propeller from turning.

- 1) Check each of the propeller blades for wear, erosion from cavitation or ventilation, or other damage.
- 2) Check the splines for wear and damage.
- 3) Check for fish line winding around the propeller shaft.
Check the propeller shaft oil seal for damage.

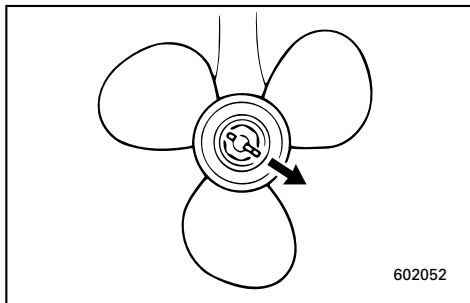
**[How to remove propeller]**

- 1) Using the pliers provided, straighten the cotter-pin and pull it out.
 - 2) Remove the propeller nut.
 - 3) Remove the propeller.
- ① Thrust washer
 - ② Propeller
 - ③ Washer
 - ④ Propeller nut
 - ⑤ Cotter pin

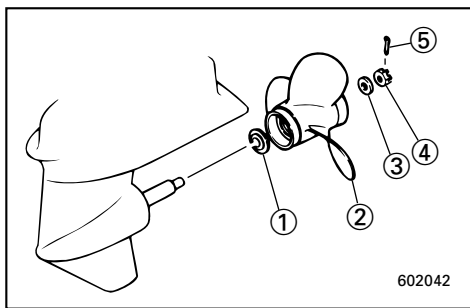
**[How to install propeller]**

- 1) Apply Yamaha Marine grease D or Marine grease (water-resistant grease) to the propeller-shaft.
- 2) Slide the propeller over the propeller-shaft.

CAUTION:

Be sure to install the thrust washer before installing propeller, otherwise, lower case and propeller boss may be damaged.

- 3) Tighten the propeller nut to the specified torque.

Tightening torque:

Refer to SPECIFICATIONS, Page 4-1

- 4) Align the propeller nut with the propeller shaft hole. Insert a new cotter pin in the hole and bend the cotter pin ends.

NOTE:

When the propeller nut does not align with the propeller shaft hole after tightening to the specified torque, then tighten it more to align the hole.

CAUTION:

Be sure to use a new cotter pin and bend the ends over securely. Otherwise, the propeller could come off during operation and be lost.

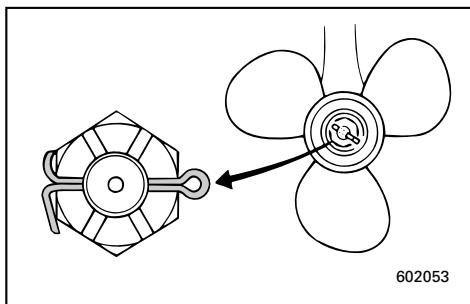



EML20010

CHANGING GEAR OIL

⚠ WARNING

Never get under the lower unit while it is tilted, even when the tilt-support lever is locked. Severe injury could occur if the outboard accidentally falls.

- 1) Put the outboard in a vertical position (not tilted).

⚠ WARNING

Be sure the outboard is securely fastened to the transom or a stable stand. You could be severely injured if the outboard falls on you.

- 2) Place a suitable container under the gearcase.
- 3) Remove the oil drain plug.

NOTE:

The oil drain plug is magnetic. Remove all metal particles from the plug before re-installing it.

- 4) Remove the oil level plug to allow the oil to drain completely.

- ① Oil-level plug
- ② Oil drain-plug

CAUTION:

Inspect the used oil after it has been drained. If the oil is milky, water is getting into the gearcase which can cause gear damage. Consult a Yamaha dealer for repair of the lower unit seals.

NOTE:

For disposal of used oil consult your Yamaha dealer.

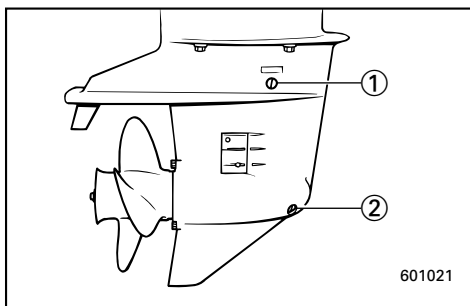
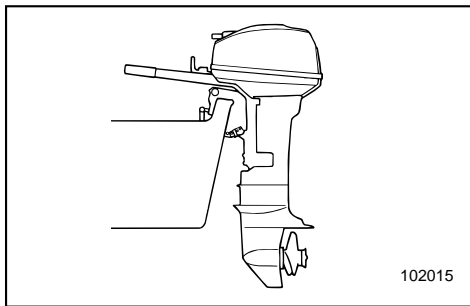

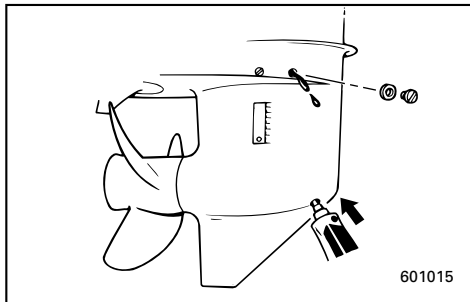

- 5) With the outboard motor in an vertical position, using a flexible or pressurized filling device, inject outboard motor hypoid gear oil (SAE 90) into the oil drain plug hole.

Gear oil capacity:
Refer to SPECIFICATIONS, Page 4-1.

- 6) When oil begins to flow out of the oil level plug hole, insert and tighten the oil level plug.
- 7) Insert and tighten in the oil drain plug.

EML22010

CLEANING FUEL TANK

⚠WARNING

Gasoline (petrol) is highly flammable, and its vapors are flammable and explosive.

- If you have any question about properly doing this procedure, consult your Yamaha dealer.
- Keep away from sparks, cigarettes, flames or other sources of ignition when cleaning the fuel tank.
- Remove the fuel tank from the boat before cleaning it. Work only outdoors in an area with good ventilation.
- Wipe up any spilled fuel immediately.
- Reassemble the fuel tank carefully. Improper assembly can result in a fuel leak, which could result in a fire or explosion hazard.
- Dispose of old gasoline according to local regulations.

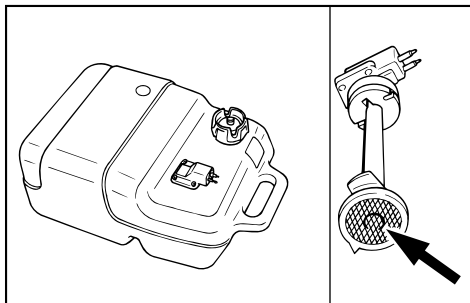
**To clean the fuel tank:**

- 1) Empty the fuel tank into an approved gasoline container.
- 2) Pour a small amount of suitable solvent in the tank. Reinstall the cap and shake the tank. Drain the solvent completely.

To clean the fuel filter:

- 1) Remove the screws holding the fuel meter assembly. Pull the assembly out of the tank.
- 2) Clean the filter (located on the end of the suction pipe) in a suitable cleaning solvent. Allow the filter to dry.
- 3) Replace the gasket with a new one. Reinstall the fuel meter assembly and tighten the screws firmly.

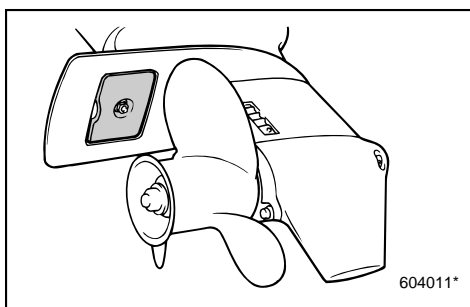

EML24010

INSPECTING AND REPLACING ANODE

Yamaha outboard motor is protected from corrosion by sacrificial anode.

Check the anode periodically. Remove the scales from surfaces of the anode.

For the replacement of the anode, consult a Yamaha dealer.

CAUTION: _____

Do not paint the anode, for this would render it ineffective.



EML40010

CHECKING BOLTS AND NUTS

- 1) Check that bolts securing the cylinder head and engine and the nut securing the flywheel are tightened with their specified tightening torques.
- 2) Check the tightening torques of other bolts and nuts.

EMU00409

MOTOR EXTERIOR

EMU00410

Cleaning the Outboard Motor

After use, wash the exterior of the outboard with fresh water.

Flush the cooling system with fresh water.

NOTE: _____

Refer to Flushing Cooling System instructions in "TRANSPORTING AND STORING OUTBOARD MOTOR".

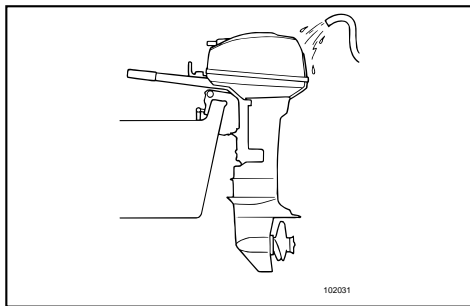

Checking Painted Surface of Motor

Check the motor for scratches, nicks, or flaking paint. Areas with damaged paint are more likely to corrode.

If necessary, clean and paint the areas.

Consult a Yamaha dealer for touch-up paint.

EML44010

COATING THE BOAT BOTTOM

A clean hull improves boat performance.

The boat bottom should be kept as clean of marine growths as possible.

If necessary, the boat bottom can be coated with an anti-fouling paint approved for your area to inhibit marine growth.

Do not use anti-fouling paint which includes copper or graphite. These paints can cause more rapid engine corrosion.

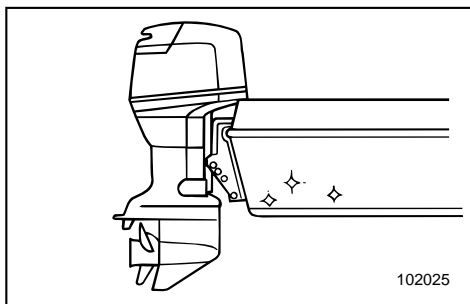

EMN00010

Chapter 5

TROUBLE RECOVERY



TROUBLESHOOTING5-1

**TEMPORARY ACTION IN
EMERGENCY**5-5

Impact damage5-5

Starter will not operate5-6

Treatment of submerged motor5-8





TROUBLESHOOTING

A problem in the fuel, compression, or ignition systems can cause poor starting, loss of power, or other problems. The troubleshooting chart describes basic checks and possible remedies. (This chart covers all Yamaha outboard motors. Therefore, some items may not apply to your model.)

If your outboard motor requires repair, bring it to a Yamaha dealer.

Trouble	Possible Cause	Remedy
A. Engine will not start (Starter operates).	<ol style="list-style-type: none">1. Fuel tank empty.2. Fuel contaminated or stale.3. Fuel filter clogged.4. Starting procedure incorrect. 5. Fuel pump malfunctions. 6. Spark plug(s) fouled or incorrect type.7. Spark plug cap(s) fitted incorrectly.8. Poor connections or damaged ignition wiring. 9. Ignition parts faulty. 10. Engine stop switch lanyard not attached.11. Shift lever in gear.12. Engine inner parts damaged.	<ol style="list-style-type: none">1. Fill tank with clean, fresh fuel.2. Fill tank with clean, fresh fuel.3. Clean or replace filter.4. Read "STARTING ENGINE" section. 5. Have serviced by a Yamaha dealer. 6. Inspect spark plug(s). Clean or replace with recommended type.7. Check and re-fit cap(s).8. Check wires for wear or breaks. Tighten all loose connections. Replace worn or broken wires. 9. Have serviced by a Yamaha dealer. 10. Attach lanyard. 11. Shift to neutral.12. Have serviced by a Yamaha dealer.



Trouble	Possible Cause	Remedy
B. Engine idles irregularly or stalls.	<ol style="list-style-type: none">1. Spark plug(s) fouled or incorrect type.2. Fuel system obstructed. 3. Fuel contaminated or stale.4. Fuel filter clogged.5. Failed ignition parts. 6. Spark plug gap incorrect.7. Poor connections or damaged ignition wiring. 8. Specified engine oil not used.9. Thermostat faulty or clogged. 10. Carburetor adjustments incorrect. 11. Fuel pump damaged. 12. Air vent screw on the fuel tank closed.13. Choke knob pulled out.14. Motor angle too high. 15. Carburetor clogged. 16. Fuel joint connection incorrect.17. Throttle valve adjustment incorrect.	<ol style="list-style-type: none">1. Inspect spark plug(s). Clean or replace with recommended type.2. Check for pinched or kinked fuel line or other obstructions in fuel system.3. Fill tank with clean, fresh fuel.4. Clean or replace filter.5. Have serviced by a Yamaha dealer.6. Inspect and adjust as specified.7. Check wires for wear or breaks. Tighten all loose connections. Replace worn or broken wires.8. Check and replace oil as specified.9. Have serviced by a Yamaha dealer.10. Have serviced by a Yamaha dealer.11. Have serviced by a Yamaha dealer.12. Open the air vent screw.13. Return to home position.14. Return to normal operating position.15. Have serviced by a Yamaha dealer.16. Connect correctly.17. Have serviced by a Yamaha dealer.



Trouble	Possible Cause	Remedy
C. Engine power loss.	<ol style="list-style-type: none">1. Propeller damaged.2. Propeller pitch or diameter incorrect.3. Trim angle incorrect.4. Motor mounted at incorrect height on transom.5. Boat bottom fouled with marine growth.6. Spark plug(s) fouled or incorrect type.7. Weeds or other foreign matter tangled on gear housing.8. Fuel system obstructed. 9. Fuel filter clogged.10. Fuel contaminated or stale.11. Spark plug gap incorrect.12. Poor connections or damaged ignition wiring. 13. Failed ignition parts. 14. Specified engine oil not used.15. Thermostat faulty or clogged. 16. Air vent screw closed.17. Fuel pump damaged. 18. Fuel joint connection incorrect.19. Heat range of spark plug incorrect. 20. Engine not responding properly to shift lever position.	<ol style="list-style-type: none">1. Have propeller repaired or replaced.2. Install correct propeller to operate outboard at its recommended speed (r/min) range.3. Adjust trim angle to achieve most efficient operation.4. Have motor adjusted to proper transom height.5. Clean boat bottom. 6. Inspect spark plug(s). Clean or replace with recommended type.7. Remove foreign matter and clean lower unit.8. Check for pinched or kinked fuel line or other obstructions in fuel system.9. Clean or replace filter.10. Fill tank with clean, fresh fuel.11. Inspect and adjust as specified.12. Check wires for wear or breaks. Tighten all loose connections. Replace worn or broken wires.13. Have serviced by a Yamaha dealer.14. Check and replace oil with specified type.15. Have serviced by a Yamaha dealer.16. Open the air vent screw.17. Have serviced by a Yamaha dealer.18. Connect correctly.19. Inspect spark plug and replace it with recommended type.20. Have serviced by a Yamaha dealer.



Trouble	Possible Cause	Remedy
D. Engine vibrates excessively.	<ol style="list-style-type: none">1. Propeller damaged.2. Propeller shaft damaged.3. Weeds or other foreign matter tangled on propeller.4. Motor mounting bolt loose.5. Steering pivot loose or damaged.	<ol style="list-style-type: none">1. Have propeller repaired or replaced.2. Have serviced by a Yamaha dealer.3. Remove and clean propeller.4. Tighten bolt.5. Tighten or have serviced by a Yamaha dealer.



EMN20010

TEMPORARY ACTION IN EMERGENCY

EMH80010

IMPACT DAMAGE

⚠️WARNING

The outboard motor can be seriously damaged by a collision while operating or trailering. Damage could make the outboard motor unsafe to operate.



If the outboard motor hits any object in the water, follow the procedure below;

- 1) Stop the engine immediately.
- 2) Inspect control system and all components for damage. Also, inspect the boat damage.
- 3) However damage is found or not found, go back to a nearest harbor slowly and carefully.
- 4) Have a Yamaha dealer inspection of the outboard motor, before operating it again.



EMN30110

STARTER WILL NOT OPERATE

If the starter mechanism does not operate (engine cannot be cranked with the starter), the engine can be started with an emergency starter rope.

⚠️WARNING

- Use this procedure only in an emergency and only to return to port for repairs.
- When the emergency starter rope is used to start the engine, the start-in-gear protection device does not operate. Make sure the transmission is in neutral. Otherwise, the boat could unexpectedly start to move, which could result in an accident.
- Be sure no one is standing behind you when pulling the starter rope. It could whip behind you and injure someone.
- An unguarded rotating flywheel is very dangerous. Keep loose clothing and other objects away when starting the engine. Use the emergency starter rope only as instructed. Do not touch the flywheel or other moving parts when the engine is running. Do not install the starter mechanism or top cowling after the engine is running.
- Do not touch the ignition coil, high voltage wire, spark plug cap or other electrical components when starting of operating the motor. You could be shocked.

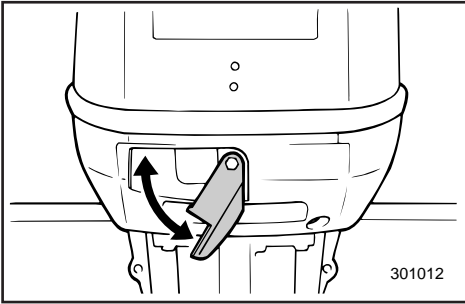

Procedure

- 1) Remove the top cowling.

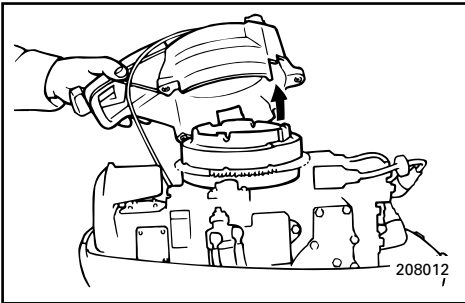

- 2) Remove the starter/flywheel cover by removing the bolts.

NOTE: _____

On a model equipped with the start-in-gear protection device (cable), disconnect the cable from the starter.

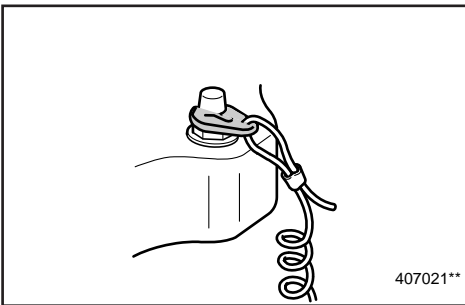

- 3) Prepare the engine for starting. See "STARTING ENGINE" for procedures. Be sure the engine is in Neutral and that the lanyard is attached to the engine stop switch.
On the electric start model the main switch must be on if the main switch is equipped.

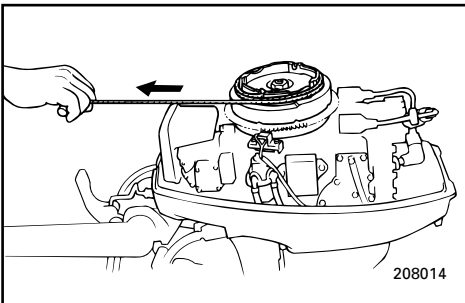

EMR00001

- 4) To start the engine with emergency starter rope, insert the knotted end of the rope into the notch in the flywheel rotor and wind the rope several turns clockwise. Then, give a strong pull straight out to crank the engine. Repeat if necessary.

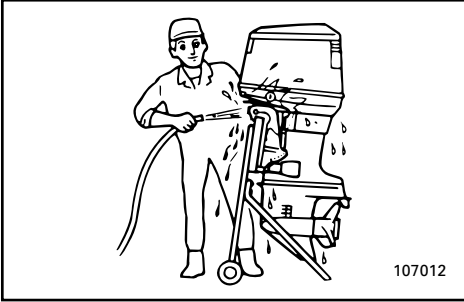

107012

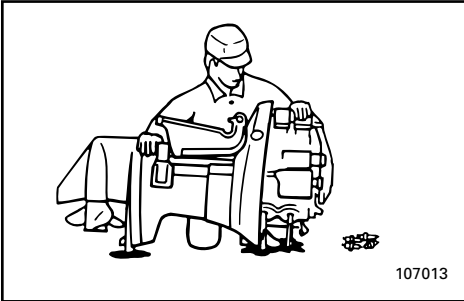

107013

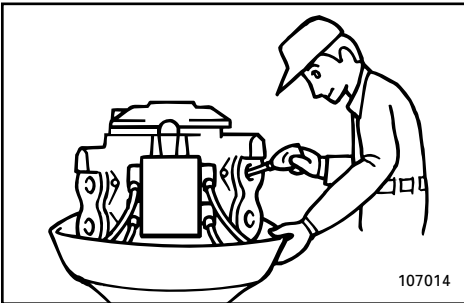

107014

EMN50011

TREATMENT OF SUBMERGED MOTOR

If the outboard motor is submerged, immediately take it to a Yamaha dealer. Otherwise, some corrosion may begin almost immediately. If you cannot immediately take the outboard motor to a Yamaha dealer, follow the procedure below for taking care to minimize engine damage.

- 1) Thoroughly wash away mud, salt, seaweed, etc. with fresh water.
- 2) Remove the spark plugs and face the spark plug holes downward to allow any water, mud or contaminants to drain.
- 3) Drain the fuel from the carburetor.
- 4) Feed fogging oil or engine oil through the carburetors and spark plug holes while cranking with the manual starter or emergency starter rope.
- 5) Take the outboard motor to a Yamaha dealer as soon as possible.

CAUTION:

Do not attempt to run the motor until it has been completely inspected.



-MEMO-

A to Z

EMP00010

Chapter 6

INDEX

INDEX.....6-1

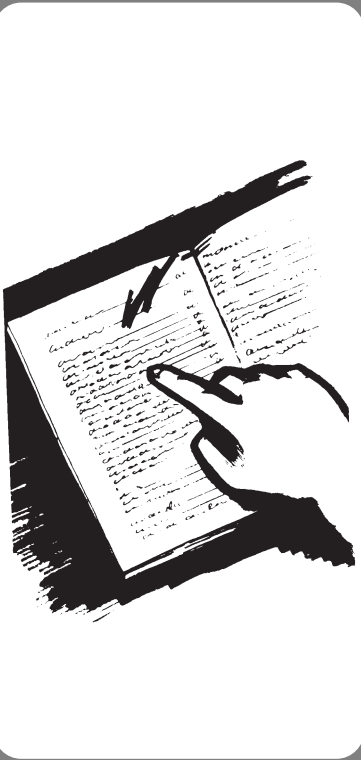

EMP10010

INDEX

- A**
 Adjusting idling speed4-13
 Adjusting trim angle3-18
 Air vent screw.....2-2
- B**
 Basic boating rules (Rules of the road) ..1-6
 Breaking in (running in) engine.....3-8
- C**
 Carrying handle.....2-7
 Changing gear oil.....4-18
 Checking bolts and nuts.....4-21
 Checking fuel system4-11
 Checking painted surface of motor.....4-21
 Checking propeller.....4-16
 Checking wiring and connectors.....4-14
 Choke knob2-4
 Clamping the outboard motor.....3-4
 Cleaning and adjusting spark plug4-9
 Cleaning and Anti-corrosion Measure...4-6
 Cleaning fuel tank4-19
 Cleaning the outboard motor4-21
 Coating the boat bottom4-21
 Cruising in other conditions3-24
 Cruising in salt water.....3-24
 Cruising in shallow water3-20
 Cruising in turbid water3-24
- E**
 Emission control information1-2
 Engine oil1-11
 Engine stop button2-3
 Engine stop lanyard switch.....2-3
 Exhaust leakage4-14
- F**
 Filling fuel3-5
 Filling fuel and engine oil.....3-5
 Filling fuel tank.....4-4
 Flushing cooling system and fogging engine.....4-5
 Forward.....3-14
- Fuel hose joint2-2
 Fuel meter.....2-2
 Fuel tank.....2-2
 Fuel tank cap.....2-2
 Fueling instructions1-10
- G**
 Gasohol1-11
 Gasoline (petrol)1-11
 Gasoline (petrol) and oil mixing.....3-6
 Gear shift lever2-2
 Greasing.....4-15
- I**
 Identification numbers record1-1
 Impact damage5-5
 Important labels1-5
 Index.....6-1
 Inspecting and replacing anode.....4-20
 Inspecting fuel filter4-12
 Installation3-1
- L**
 Lubrication.....4-6
- M**
 Main components2-1
 Maintenance chart4-8
 Motor exterior4-21
 Mounting height3-3
 Mounting the outboard motor3-2
- O**
 Operations of controls and other functions2-2
 Outboard motor serial number1-1
- P**
 Periodic maintenance4-7
 Pre-operation checks3-7
 Propeller selection1-12
- R**
 Recoil starter handle.....2-4
 Replacement parts4-7
 Reverse3-15
- S**
 Safety information1-3

Shifting.....	3-14
Specification data	4-1
Start-in-gear protection.....	1-13
Starter will not operate.....	5-6
Starting engine.....	3-10
Steering friction adjustment.....	2-6
Stopping engine.....	3-16
Storing outboard motor	4-4
T	
Temporary action in emergency.....	5-5
Throttle control grip.....	2-4
Throttle friction adjustment.....	2-5
Throttle indicator	2-4
Tiller handle.....	2-5
Tilt lock mechanism.....	2-6
Tilt support bar.....	2-7
Tilting up/down	3-22
Top cowling lock lever	2-7
Trailing outboard motor	4-3
Transporting and storing outboard motor.....	4-3
Treatment of submerged motor	5-8
Trim angle adjusting rod.....	2-6
Trimming outboard motor.....	3-17
Troubleshooting.....	5-1
W	
Warming up engine.....	3-13
Warning labels	1-5
Warranty information	Next page
Water leakage.....	4-14

IMPORTANT WARRANTY INFORMATION FOR U.S.A. AND CANADA

Welcome to the Yamaha Family!

Congratulations on the purchase of your new Yamaha marine power. Yamaha is committed to exceptional customer satisfaction, and we want your ownership experience to be a satisfying one. Please read the following warranty information to help ensure satisfaction with your Yamaha.

Yamaha is ready to stand behind your purchase with strong warranty coverage. To be sure you receive all the benefits of warranty, please take the following steps:

1. Be sure your new Yamaha is registered for warranty. Your boat dealer should do this at the time of sale. Make sure your dealer gives you a copy of the completed Yamaha registration card for your records. If you are unsure whether or not your Yamaha is registered, complete the Warranty Registration card found inside the cover of the Owner's Manual. Mail it to the distributor for the country in which you live (see step 6 for the correct address). If your Yamaha is not properly registered, a warranty repair could be unnecessarily delayed while registration records are checked.
2. Read the Limited Warranty statement which follows these instructions. This warranty applies to Yamaha outboard motors sold in the United States, whether purchased separately or when supplied as original equipment by a boat builder. The terms also apply to original equipment packages sold in Canada, with coverage provided by Yamaha Motor Canada (see "Warranty Guide" for Canadian models). This warranty explains the conditions of the warranty, including the obligations that your dealer and you as the owner have under the warranty. For example, your Yamaha outboard must receive a proper pre-delivery inspection (PDI) by the selling dealer. Failure to take this important step could jeopardize warranty coverage!
3. If you need warranty repairs, you must take your Yamaha outboard to an authorized Yamaha outboard dealer. Be aware that not all selling boat dealers are authorized Yamaha dealers. Only authorized dealers have the factory training, special tools, and Yamaha support needed to perform warranty repairs.
4. If you are away from home, or your selling dealer is not an authorized Yamaha dealer, use the following toll-free numbers to find the nearest Yamaha dealer.

United States Dealer Locations: 1-800-692-6242

Canada Dealer Locations: 1-800-267-8577

5. Your warranty applies specifically to repairs made in the country of purchase. If your U.S.-purchased Yamaha needs warranty service while in Canada, or your Canadian purchased Yamaha needs service while in the United States, Yamaha will assist the local dealer whenever possible. However, some products available in one country may not be sold or serviced in the other.
6. If you need any additional information about your Yamaha or warranty coverage which your dealer cannot provide, please contact us directly.

Yamaha Motor Corporation, U.S.A.
P.O. Box 6555
Cypress, CA 90630
Attention: Customer Relations Department

Telephone No. (714) 761-7439
Fax No. (714) 761-7559

Yamaha Motor Canada Ltd.
480 Gordon Baker Road
Toronto, Ontario
M2H 3B4
Attention: Customer Relations Department

Telephone No. (416) 498-1911
Fax No. (416) 491-3122

YAMAHA MOTOR CORPORATION, U.S.A.

OUTBOARD MOTOR TWO YEAR LIMITED WARRANTY

Yamaha Motor Corporation, U.S.A. is proud of its heritage and reputation for producing products with high standards of quality and workmanship. Product excellence provides the cornerstone for our commitment to customer satisfaction. The Yamaha Outboard Limited Warranty is your assurance of this commitment.

This warranty provides you with protection against the expense of repairs for your outboard motor that are required as a result of defects in materials or workmanship. When maintained and utilized in the prescribed manner, you can count on your Yamaha outboard to provide reliable service.

This warranty provides you with specific coverage and notes your responsibilities in maintaining and operating your outboard. Please take the time to read and become familiar with this warranty.

PERIOD OF WARRANTY. Any new Yamaha outboard motor purchased and registered with Yamaha Motor Corporation, U.S.A. for pleasure use in the United States, will be warranted against defects in material or workmanship for a period of two (2) years from date of purchase, subject to exclusions noted herein. Any Yamaha outboard motor purchased and utilized for commercial applications will be warranted for a period of one (1) year from the date of purchase, subject to exclusions noted herein. Yamaha peripheral equipment included with the motor, such as gauges, fuel tanks and hoses, remote control boxes, propellers, and wiring external from the motor unit, will be warranted for one (1) year from the date of purchase for either pleasure or commercial use. Replacement parts used in warranty repairs will be warranted for the balance of the applicable warranty period.

The second year of warranty (if applicable) shall be limited to covering the cost of parts and labor for major components only. The major components covered are:

Power Unit Section

- Power Head
- Intake Manifold and Reed Valve Assembly
- Carburetor Assembly and its Related Components
- Fuel and Oil Pump Assemblies
- Ignition System (Standard and Microcomputer)
- Precision Blend ® System

Bracket Section

- Bracket System
- Power Trim and Tilt Assembly

Lower Unit Section

- Exhaust System
- Upper Casing
- Lower Unit Assembly

The warranty described here applies to outboard motor purchased and registered for use in the United States only excluding its territories. For warranty provisions outside the United States, contact the particular country's local Yamaha distributor.

WARRANTY REGISTRATION. To be eligible for warranty coverage, the outboard motor must first be registered with Yamaha Motor Corporation, U.S.A. A warranty registration form is provided in the Owner's Manual with each outboard. This form must be completed and mailed to Yamaha by either the selling dealer or the purchaser. Warranty registration can also be accomplished by any authorized Yamaha outboard dealer. Upon receipt of the registration, an Owner's Warranty Card will be sent by Yamaha to the registered purchaser.

OBTAINING REPAIRS UNDER WARRANTY. To receive repairs under this warranty, a valid Owner's Warranty Card must be presented to an authorized Yamaha outboard dealer.

During the period of warranty, any authorized Yamaha outboard dealer will, free of charge, repair or replace, at Yamaha's option, any parts adjudged defective by Yamaha due to faulty workmanship or material from the factory. All replaced parts will become the property of Yamaha Motor Corporation, U.S.A.

CUSTOMER'S RESPONSIBILITY. Under the terms of this warranty, the customer will be responsible for ensuring that the outboard motor is properly operated, maintained and stored as specified in the applicable Owner's Manual.

The owner of the outboard motor shall give notice to an authorized Yamaha marine dealer of any and all apparent defects within ten (10) days of discovery and make the motor available at that time for inspection and repairs at the dealer's place of business.

GENERAL EXCLUSIONS FROM WARRANTY. This warranty will not cover the repair of damage if the damage is a result of abuse or neglect of the product. Examples of abuse and neglect include, but are not limited to:

1. Racing or competition use, modification of original parts, abnormal strain.
2. Lack of proper maintenance and off-season storage as described in the Owner's Manual, improper mounting of the motor, installation of parts or accessories that are not equivalent in design and quality to genuine Yamaha parts.
3. Operation of the motor at an rpm other than specified, improper propeller selection, use of lubricants, oils, and fuel/oil mixtures that are not suitable for outboard motor use.
4. Damage as a result of accidents, collisions, contact with foreign materials, or submersion.
5. Growth of marine organisms on motor surfaces.
6. Normal deterioration.

SPECIFIC PARTS EXCLUDED FROM WARRANTY. Parts replaced due to normal wear or routine maintenance such as oil, spark plugs, shear pins, propellers, hubs, fuel and oil filters, brushes for the starter motor and power tilt motor, water pump impellers, and anodes are not covered by warranty. Charges for removal of the motor from a boat and transporting the motor to and from an authorized Yamaha outboard dealer are excluded from warranty coverage.

Specific parts excluded from the second year of warranty (if applicable) are:

- Top and Bottom Cowling
- Electric Components (other than ignition system)
- Rubber Components (such as hoses, tubes, rubber seals, fittings, and clamps)

TRANSFER OF WARRANTY. Transfer of the warranty from the original purchaser to any subsequent purchaser is possible by having the motor inspected by an authorized Yamaha outboard dealer and requesting the dealer to submit a change of registration to Yamaha Motor Corporation, U.S.A. within ten (10) days of the transfer.

EMISSION CONTROL SYSTEM WARRANTY. Yamaha warrants to the ultimate purchaser and each subsequent purchaser, that this engine is designed, built, and equipped so as to conform at the time of sale with applicable regulations under section 213 of the Clean Air Act and this engine is free from defects in materials and workmanship which cause said engine to fail to conform with applicable regulations for one (1) year from date of purchase.

YAMAHA MOTOR CORPORATION, U.S.A. MAKES NO OTHER WARRANTY OF ANY KIND, EXPRESSED OR IMPLIED. ALL IMPLIED WARRANTIES OF MERCHANTABILITY AND FITNESS FOR A PARTICULAR PURPOSE WHICH EXCEED THE OBLIGATIONS AND TIME LIMITS STATED IN THIS WARRANTY ARE HEREBY DISCLAIMED BY YAMAHA MOTOR CORPORATION, U.S.A. AND EXCLUDED FROM THIS WARRANTY.

SOME STATES DO NOT ALLOW LIMITATIONS ON HOW LONG AN IMPLIED WARRANTY LASTS, SO THE ABOVE LIMITATION MAY NOT APPLY TO YOU. ALSO EXCLUDED FROM THIS WARRANTY ARE ANY INCIDENTAL OR CONSEQUENTIAL DAMAGES INCLUDING LOSS OF USE. SOME STATES DO NOT ALLOW THE EXCLUSION OR LIMITATION OF INCIDENTAL OR CONSEQUENTIAL DAMAGES, SO THE ABOVE EXCLUSION MAY NOT APPLY TO YOU.

THIS WARRANTY GIVES YOU SPECIFIC LEGAL RIGHTS, AND YOU MAY ALSO HAVE OTHER RIGHTS WHICH VARY FROM STATE TO STATE.

**YAMAHA MOTOR CORPORATION, U.S.A.
Post Office Box 6555
Cypress, California 90630**

WARRANTY QUESTIONS AND ANSWERS

- Q. What costs are my responsibility during the warranty period?
A. The customer's responsibility includes all costs of normal maintenance services, non-warranty repairs, accident and collision damages.
- Q. What are some examples of "abnormal" strain, neglect, or abuse?
A. These terms are general and overlap each other in areas. Specific examples include:
Running the machine out of oil, operating the machine with a broken or damaged part which causes another part to fail, damage or failure due to improper or careless transportation, and/or tie down. If you have any specific questions on operation or maintenance, please contact your Yamaha outboard dealer for advice.
- Q. Does the warranty cover incidental costs such as towing or transportation due to a failure?
A. No. The warranty is limited to repair of the machine itself.
- Q. May I perform any or all of the recommended maintenance shown in the Owner's Manual instead of having the dealer do them?
A. Yes, if you are a qualified mechanic and follow the procedures specified in the Owner's and Service Manuals. We do recommend, however, that items requiring special tools or equipment be done by a Yamaha outboard dealer.
- Q. Will the warranty be void or canceled if I do not operate or maintain my new outboard exactly as specified in the Owner's Manual?
A. No. The warranty on a new outboard cannot be "voided" or "canceled". However, if a particular failure is caused by operation or maintenance other than as shown in the Owner's Manual, that failure may not be covered under warranty.
- Q. What responsibility does a Yamaha outboard dealer have under this warranty?
A. Each Yamaha outboard dealer is expected to:
1. Completely set up each outboard he sells prior to delivery.
2. Explain the operation, maintenance, and warranty requirements to your satisfaction at the time of sale, and upon your request at any later date.
In addition, each Yamaha outboard dealer is held responsible for his setup, service and warranty repair work.
- Q. Is the warranty transferable to second owners?
A. Yes. The remainder of any existing warranty can be transferred upon request. The unit has to be inspected and re-registered by an authorized Yamaha outboard dealer for the policy to remain effective.

CUSTOMER SERVICE

If your machine requires warranty service, you must take it to any authorized Yamaha outboard dealer within the continental United States. Be sure to bring your warranty registration identification or other valid proof of the original date of purchase. If a question or problem arises regarding warranty, first contact the owner of the dealership. Since all warranty matters are handled at the dealer level, this person is in the best position to help you. If you are still not satisfied and require additional assistance, please write:

YAMAHA MOTOR CORPORATION U.S.A.
CUSTOMER RELATIONS DEPARTMENT
P.O.Box 6555
Cypress, California 90630

When contacting Yamaha Motor Corporation, U.S.A. don't forget to include any important information such as names, addresses, model, engine serial number, dates, and receipts.

CHANGE OF ADDRESS

The federal government requires each manufacturer of a motor vehicle to maintain a complete, up-to-date list of all first purchasers against the possibility of a safety-related defect and recall. This list is compiled from the purchase registrations sent to Yamaha Motor Corporation, U.S.A. by the selling dealer at the time of your purchase.

If you should move after you have purchased your new outboard, please advise us of your new address by sending a postcard listing your outboard model name, engine serial number, dealer number (or dealer's name) as it is shown on your warranty identification, your name and new mailing address. Mail to:

YAMAHA MOTOR CORPORATION, U.S.A.
WARRANTY DEPARTMENT
P.O.Box 6555
Cypress, California 90630

This will ensure that Yamaha Motor Corporation, U.S.A. has an up-to-date registration record in accordance with federal law.

IMPORTANT WARRANTY INFORMATION IF YOU USE YOUR YAMAHA OUTSIDE U.S.A. OR CANADA

Welcome to the Yamaha Family!

Congratulations on the purchase of your new Yamaha marine power. Yamaha is committed to exceptional customer satisfaction, and we want your ownership experience to be a satisfying one. Please read the following warranty information to help ensure satisfaction with your Yamaha.

This model was manufactured as a U.S.A. specification model, and the warranty statement shown in this manual is for market. To receive the benefits of the warranty that applies to the country in which you use your Yamaha, please note the following information.

1. The warranty on this model is the same as equivalent models sold in the country where you will receive service. If you need more information about your warranty coverage or your Yamaha outside the U.S.A. or Canada, please contact an authorized Yamaha dealer in your country.
2. Keep a copy of your sales contract or invoice for the purchase of your Yamaha and present it if you need warranty repairs. This document should show the date of purchase, which is important evidence the repairing dealer will need to be sure your Yamaha is covered by warranty.
3. If your Yamaha needs warranty repairs, contact an authorized Yamaha dealer in the country where you are. He will explain how to get warranty service in that country.
4. This Yamaha model may not be sold in some countries. Therefore, in some cases your local dealer may not have all the parts or service information he may need, which may unavoidably delay repairs. If this happens, we thank you for your understanding and assure you we will attempt to resolve the situation as quickly as possible.



YAMAHA MOTOR CORPORATION, USA

Printed in Japan

March 2001—0.5 × 1 

63V-28199-14

(9.9FMH/15FMH)

(E)

Printed on recycled paper



OW

 **YAMAHA**

9.9A/15A