

# *Compact Hi-Fi Stereo System*

---

## Operating Instructions

## Owner's Record

The model and serial numbers are located on the rear panel. Record the serial number in the space provided below. Refer to them whenever you call upon your Sony dealer regarding this product.

Model No. \_\_\_\_\_ Serial No. \_\_\_\_\_



***Game SYNC***

***LBT-XG700***

***LBT-XG500***

***LBT-XG80***

***LBT-XG60***

## WARNING

### To prevent fire or shock hazard, do not expose the unit to rain or moisture.

To avoid electrical shock, do not open the cabinet. Refer servicing to qualified personnel only.

Do not install the appliance in a confined space, such as a bookcase or built-in cabinet.

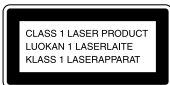

This appliance is classified as a CLASS 1 LASER product. The CLASS 1 LASER PRODUCT MARKING is located on the rear exterior.

To prevent fire, do not cover the ventilation of the apparatus with newspapers, table-cloths, curtains, etc. And don't place lighted candles on the apparatus.

To prevent fire or shock hazard, do not place vases on the apparatus.



Don't throw a battery, dispose it as the injurious wastes.

### NOTICE FOR THE CUSTOMERS IN THE U.S.A.

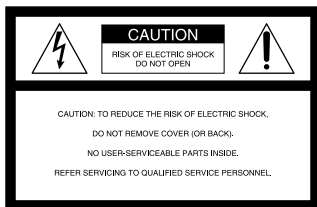

This symbol is intended to alert the user to the presence of uninsulated "dangerous voltage" within the product's enclosure that may be of sufficient magnitude to constitute a risk of electric shock to persons.



This symbol is intended to alert the user to the presence of important operating and maintenance (servicing) instructions in the literature accompanying the appliance.

### CAUTION

The use of optical instruments with this product will increase eye hazard.

## WARNING

This equipment has been tested and found to comply with the limits for a Class B digital device, pursuant to Part 15 of the FCC Rules. These limits are designed to provide reasonable protection against harmful interference in a residential installation. This equipment generates, uses, and can radiate radio frequency energy and, if not installed and used in accordance with the instructions, may cause harmful interference to radio communications. However, there is no guarantee that interference will not occur in a particular installation. If this equipment does cause harmful interference to radio or television reception, which can be determined by turning the equipment off and on, the user is encouraged to try to correct the interference by one or more of the following measures:

- Reorient or relocate the receiving antenna.
- Increase the separation between the equipment and receiver.
- Connect the equipment into an outlet on a circuit different from that to which the receiver is connected.
- Consult the dealer or an experienced radio/TV technician for help.

## CAUTION

You are cautioned that any changes or modifications not expressly approved in this manual could void your authority to operate this equipment.

### NOTICE FOR THE CUSTOMERS IN CANADA

#### CAUTION:

**TO PREVENT ELECTRIC SHOCK, DO NOT USE THIS POLARIZED AC PLUG WITH AN EXTENSION CORD, RECEPTACLE OR OTHER OUTLET UNLESS THE BLADES CAN BE FULLY INSERTED TO PREVENT BLADE EXPOSURE.**

For the customers in North America



ENERGY STAR® is a U.S. registered mark. As an ENERGY STAR® partner, Sony Corporation has determined that this product meets the ENERGY STAR® guidelines for energy efficiency.

This stereo system is equipped with the Dolby B-type noise reduction system\*.

\* Manufactured under license from Dolby Laboratories Licensing Corporation. DOLBY and the double-D symbol  are trademarks of Dolby Laboratories Licensing Corporation.

# Table of Contents

## Parts Identification

Main unit .....	4
Remote control .....	5

## Getting Started

Hooking up the system .....	6
Inserting two size AA (R6) batteries into the remote .....	8
Setting the time .....	8
Saving the power in standby mode .....	8

## CD

Loading the CD .....	9
Playing the CD — Normal Play/Shuffle Play/ Repeat Play .....	9
Playing CDs without interruption — Non-Stop Play .....	10
Programming the CD tracks — Program Play .....	10
DJ Effects .....	11
Using the CD display .....	11

## Tuner

Presetting radio stations .....	12
Listening to the radio — Preset Tuning .....	13
Using the Radio Data System (RDS)* ..	13

## Tape

Loading a tape .....	15
Playing a tape .....	15
Recording to a tape — CD Synchro Recording/ High Speed Dubbing/Recording Manually/Program Edit .....	16
Timer-recording radio programs .....	17

## Sound Adjustment

Adjusting the sound .....	18
Selecting the audio emphasis effect ....	18
Selecting the surround effect .....	18
Making a personal audio emphasis file — Personal File .....	19

## Other features

Changing the spectrum analyzer display .....	20
Singing along: Karaoke .....	20
Playing a guitar .....	21
Enhancing video game sound — Game Sync .....	21
Falling asleep to music — Sleep Timer .....	21
Waking up to music — Daily Timer .....	22

## Hooking up the optional components

Connecting MD deck/VCR/camcorder/ video game .....	23
Connecting a turntable/mixer .....	24

## Additional Information

Precautions .....	25
Troubleshooting .....	26
Specifications .....	28

\* For European models only

The items are arranged in alphabetical order.

Refer to the pages indicated in parentheses ( ) for details.

## Main unit

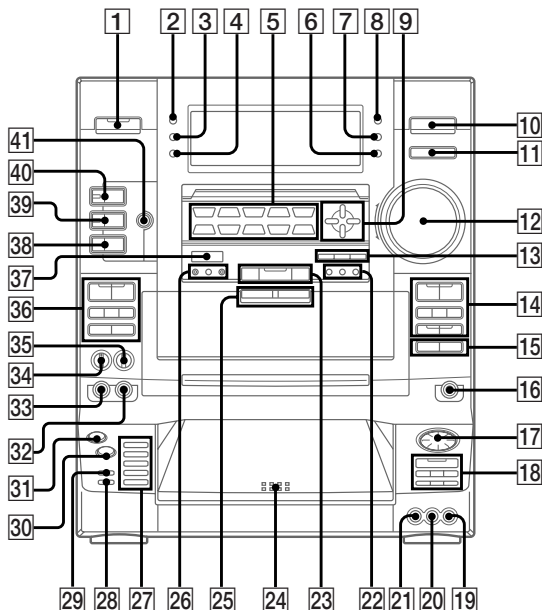

A EJECT ▲/▲ B EJECT 25 (15)  
 AUDIO L 20 (23)  
 AUDIO R 19 (23)  
 CD SYNC 15 (16,17)  
 DIRECT EQUALIZER 5 (18)  
 SALSA  
 REGGAE  
 SAMBA  
 TANGO  
 MOVIE  
 GUITAR  
 ROCK  
 JAZZ  
 DANCE  
 GAME  
 DIRECTION 36 (15,16,17)  
 DISC SKIP 18 (9,10,17)  
 DISC 1~5 27 (9)  
 DISPLAY 3 (8,11,13)  
 DOLBY NR 36 (15,16)  
 EDIT 29 (17)  
 ENTER 26 (12,14)  
 ENTER/NEXT 13 (8,17,19,22,27)  
 FLASH 30 (11)

FLAT 13 (18)  
 FUNCTION 10 (7,9,10,16,17,23,24)  
 GAME 11 (21)  
 GROOVE 40 (18)  
 GUITAR DISTORTION 26 (21)  
 GUITAR jack 32 (21)  
 GUITAR LEVEL 35 (21)  
 H SPEED DUB 15 (16)  
 Jog dial (AMSI◀◀/▶▶) 17  
 (9,10,11,17)  
 LOOP 31 (7,11)  
 MIC LEVEL 34 (20)  
 MIX GUITAR/KARAOKE 37 (20,21)  
 MIX MIC jack 33 (20)  
 NON STOP 28 (10)  
 P.FILE 13 (18,19)  
 PHONES jack 16  
 PLAY MODE 18 (9,10,17)  
 POWER SAVE/DEMO  
 (STANDBY) 2 (8)  
 PTY 22 (14) \*European model only  
 PUSH OPEN 24 (9)  
 REPEAT 18 (9)  
 SLEEP 7 (21)

SPECTRUM ANALYZER 4 (20)  
 STEREO/MONO 22 (13)  
 SUPER WOOFER MODE 39 (18)  
 SUPER WOOFER MODE 38 (18)  
 SURROUND 41 (16,18)  
 TIMER SELECT 8 (17, 22)  
 TUNER/BAND 23 (12,13,16)  
 TUNER MEMORY 26 (12)  
 TUNING MODE 22 (12,13)  
 VIDEO 21 (23)  
 VOLUME control 12 (9,13)

### BUTTON DESCRIPTIONS

I/⏻ 1  
 ⌚/CLOCK SET 6  
 ▲▼/◀▶ 9  
 ● REC 14  
 || 14  
 ◀▶, AMSI◀◀/▶▶ 14 36  
 ◀, ▶ 14 36  
 ■ 14 18 36  
 ◀▶▶▶ 18  
 ▷|| 18  
 +/- 23

# Remote control

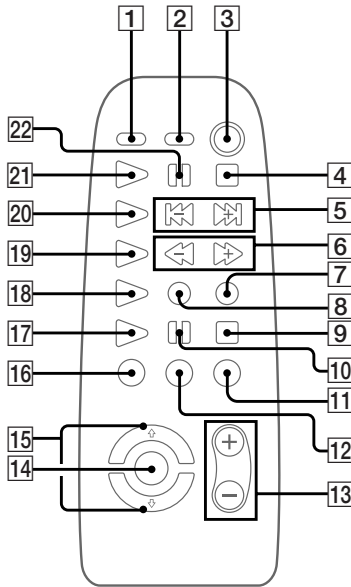

AMS **1** ◀◀/▶▶, PRESET+/- **5**

(9,13,14,15)

CD ▶ **21** (9)

CHECK **8** (10)

CLEAR **7** (10)

DECK A ▶ **19** (15)

DECK B ▶ **18** (15)

DISC SKIP **1** (9,10,17)

FILE SELECT ON/OFF **14** (18)

FILE SELECT ◊/◊ **15** (11)

FLASH **12** (11)

FUNCTION **11** (7,9,10,16,17,23,24)

LOOP **16** (11)

MD ▶ **17**

MD **10**

MD **9**

SLEEP **2** (21)

TUNER/BAND **20** (12,16)

VOL +/- **13** (9,13)

## BUTTON DESCRIPTIONS

⏻/⏻ **3**

■ **4**

◀◀/▶▶ **6**

⏸ **22**

## Hooking up the system

Do the following procedure **1** to **4** to hook up your system using the supplied cords and accessories.

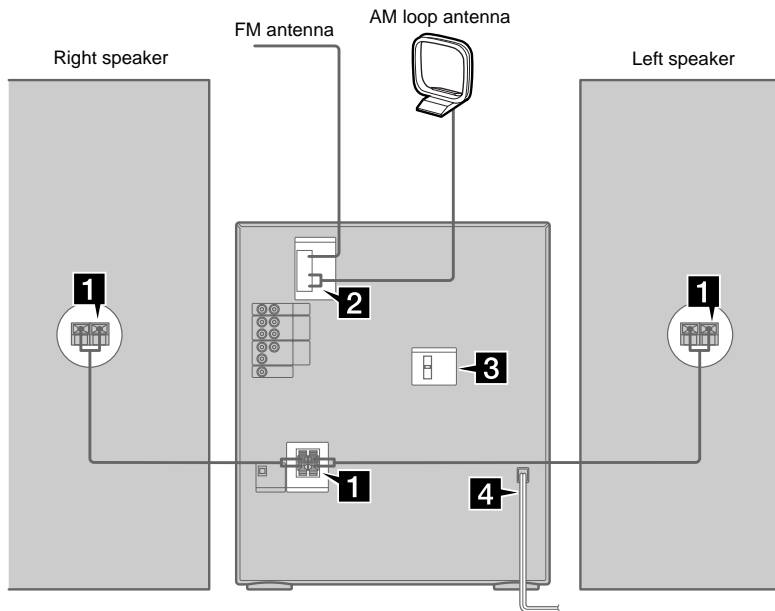

### 1 Connect the speakers.

Connect the speaker cords to the SPEAKER jacks as below.

Insert only the stripped portion.

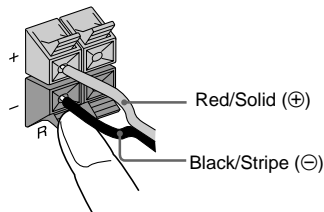

#### Note

Keep the speaker cords away from the antennas to prevent noise.

### 2 Connect the FM/AM antennas.

Set up the AM loop antenna, then connect it.

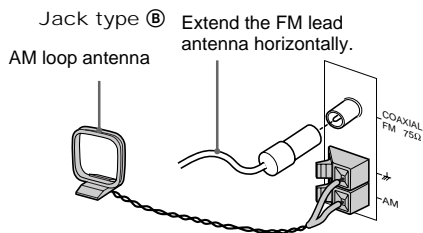
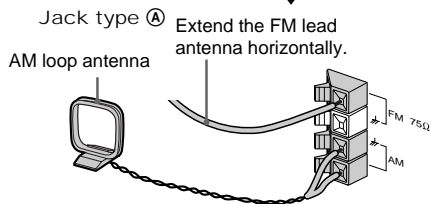
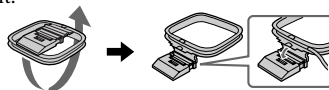

- 3 For models with a voltage selector, set VOLTAGE SELECTOR to the position of your local power line voltage.**

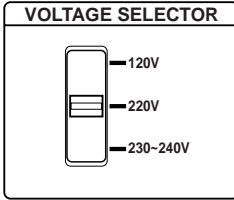

- 4 Connect the power cord to a wall outlet.**

The demonstration appears in the display. When you press **I/⏻**, the system turns on and the demonstration automatically ends.

If the supplied adaptor on the plug does not fit your wall outlet, detach it from the plug (only for models equipped with the adaptor).

When carrying this system

Do the following to protect the CD mechanism.

- 1** Make sure that all discs are removed from the unit.
- 2** Press **FUNCTION** repeatedly until "CD" appears.
- 3** Hold down **LOOP** and then press **I/⏻** until "LOCK" appears.
- 4** Unplug the AC power cord.

Before connecting the Front speaker

Stick the supplied front speaker pads to the bottom of the front speakers to stabilize the speakers and prevent them from slipping.

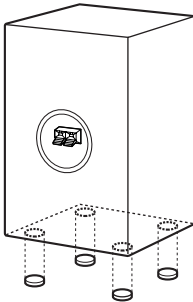

Notice for customers in the United Kingdom

The AC power cord has been fixed temporarily on the rear panel with the plug band for shipment. Unlock the plug band to remove the plug.

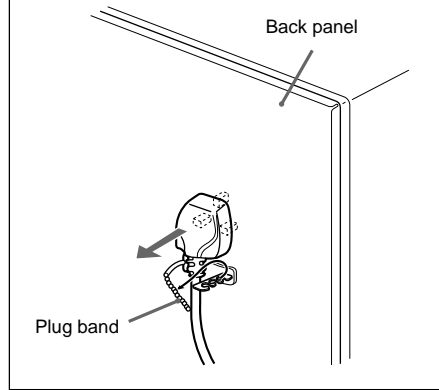

## Inserting two size AA (R6) batteries into the remote

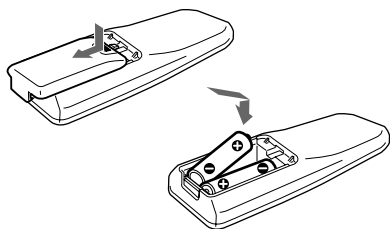

### Tip

When the remote no longer operates the system, replace both batteries with new ones.

### Note

If you do not use the remote for a long period of time, remove the batteries to avoid possible damage from battery leakage.

## Setting the time

- 1 Turn on the system.**
- 2 Press  $\odot$ /CLOCK SET.**  
When you set the time for the first time, skip to the step 5.
- 3 Press  $\blacktriangle$ / $\blacktriangledown$  repeatedly to select SET CLOCK.**
- 4 Press ENTER/NEXT.**
- 5 Press  $\blacktriangle$ / $\blacktriangledown$  repeatedly to set the hour.**
- 6 Press ENTER/NEXT.**  
The minute indication flashes.
- 7 Press  $\blacktriangle$ / $\blacktriangledown$  repeatedly to set the minute.**
- 8 Press ENTER/NEXT.**  
The clock starts working.

### Tip

If you've made a mistake or want to change the time, start over from step 1.

### Note

The clock settings are canceled when you disconnect the power cord or if a power failure occurs.

## Saving the power in standby mode

**Press POWER SAVE/DEMO (STANDBY) when the power is off. Every time you press the button, the system switches as follows:**

Power Saving Mode  $\leftrightarrow$  Demonstration

The system is turned on/off by pressing I/ $\odot$ .

### Tips

- I/ $\odot$  indicator lights up even in the Power Saving Mode.
- The timer works in the Power Saving Mode.
- Everytime you press DISPLAY when the power is off, the display changes as follows:  
Demonstration  $\leftrightarrow$  Clock

### Note

You cannot set the time in the Power Saving Mode.

To cancel the Power Saving Mode  
Press POWER SAVE/DEMO (STANDBY) to show the demonstration.



## Loading the CD

- 1 Press **PUSH OPEN**.  
The front cover opens.
- 2 Place a CD with the label side up on the disc tray.

When you play a CD single, place it on the inner circle of the tray.

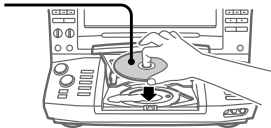

To insert additional discs, press **DISC SKIP** to rotate the disc tray.

- 3 Close the front cover.

## Playing the CD

### —Normal Play/Shuffle Play/Repeat Play

This unit lets you play the CD in different play modes.

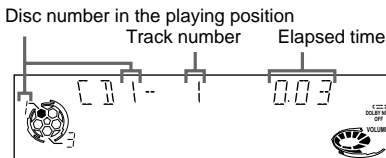

- 1 Press **FUNCTION** repeatedly until “CD” appears.
- 2 Press **PLAY MODE** repeatedly until the mode you want appears.

Select	To play
ALL DISCS	All CDs in the disc tray continuously.
1 DISC	The CD you selected in the original order.
ALL DISCS SHUFFLE	The tracks on all CDs in random order.
1 DISC SHUFFLE	The tracks on the CD you selected in random order.
PROGRAM	The tracks on all CDs in the order you want them to be played (see “Programming the CD tracks” on page 10).

- 3 Press **▷||** (or **CD ▶** on the remote).

## Other Operations

To	Do this
Stop playback	Press <b>■</b> .
Pause	Press <b>▷  </b> (or <b>  </b> on the remote). Press again to resume play.
Select a track	During play or pause, turn the jog dial clockwise (to go forward) or counterclockwise (to go backward) (or press <b>AMS◀◀</b> (to go forward) or <b>AMS▶▶</b> (to go backward) on the remote).
Find a point in a track	Press and hold <b>▶▶</b> or <b>◀◀</b> during playback, and release at the desired point.
Select a CD	Press <b>DISC 1~5</b> or <b>DISC SKIP</b> (or <b>DISC SKIP</b> on the remote).
Switch to CD function from another source	Press <b>DISC 1~5</b> or <b>▷  </b> (or <b>CD ▶</b> on the remote) (Automatic Source Selection).
Play repeatedly (Repeat Play)	Press <b>REPEAT</b> during playback until “REPEAT” or “REPEAT1” appears. REPEAT: For all the tracks on the CD. REPEAT1: For a single track only. To cancel playing repeatedly, press <b>REPEAT</b> until “REPEAT” or “REPEAT1” disappears.
Remove the CD	Press <b>PUSH OPEN</b> .
Adjust the volume	Turn <b>VOLUME</b> (or press <b>VOL +/-</b> on the remote).

### Tip

You can change the CD in the loading position during playback of the CD in the playing position.

## Playing CDs without interruption

### — Non-Stop Play

You can play CDs without pausing between tracks.

- 1 Press **FUNCTION** repeatedly until “**CD**” appears, then load a CD.
- 2 Press **NON STOP** so that the indicator on this button lights up.
- 3 Press **▷||**.

To cancel Non-Stop Play

Press **NON STOP** so that the indicator on this button goes off.

## Programming the CD tracks

### — Program Play

You can make a program of up to 32 tracks from all the CDs in the order you want them to be played.

- 1 Press **FUNCTION** repeatedly until “**CD**” appears, then load a CD.
- 2 Press **PLAY MODE** repeatedly until “**PROGRAM**” appears.
- 3 Press **DISC SKIP** to select a CD.
- 4 Turn the jog dial until the track you want appears.
- 5 Press **PLAY MODE** once.  
The track is programmed. First “**STEP**” and the programmed playing order appear, then the total playing time appears.
- 6 To program additional tracks, repeat steps 3 to 5.  
Skip step 3 to select tracks from the same disc.
- 7 Press **▷||**.

To	Press
Cancel Program Play	<b>PLAY MODE</b> repeatedly until “ <b>PROGRAM</b> ,” “ <b>ALL DISCS SHUFFLE</b> ” or “ <b>1 DISC SHUFFLE</b> ” disappears.
Check the program	<b>CHECK</b> on the remote repeatedly. After the last track, “ <b>CHECK END</b> ” appears.
Clear a track from the end	<b>CLEAR</b> on the remote in stop mode.
Clear a specific track in stop mode	<b>CHECK</b> on the remote repeatedly until the number of the track to be erased lights up, then press <b>CLEAR</b> .
Add a track to the program in stop mode	<ol style="list-style-type: none"><li>1 Press <b>DISC SKIP</b> to select a CD.</li><li>2 Turn the jog dial to select a track.</li><li>3 Press <b>PLAY MODE</b>.</li></ol>
Clear the entire program	■ once in stop mode or twice while playing.

### Tips

- The program you made remains in the CD player after it has been played back. Press **▷||** to play the same program again.
- If “**--**” appears instead of the total playing time during programming, this means:
  - you have programmed a track number which exceeds 20.
  - the total playing time has exceeded 100 minutes.

## DJ Effects

### Looping and flashing part of a CD

With the loop function, you can repeat part of a CD during playback. With the flash function, you can “flash” part of a CD sound during playback. Both functions let you create original recordings.

To	Do this
Start the function at the point you want	Press and hold LOOP or FLASH during playback.
Resume normal play	Release LOOP or FLASH.
Adjust the function length (LOOP lengths or FLASH lengths)	Turn the jog dial while holding LOOP or FLASH (or press FILE SELECT $\leftarrow/\rightarrow$ while holding LOOP or FLASH on the remote).
Use FLASH and LOOP together	Press and hold both LOOP and FLASH at the same time.

#### Notes

- Adjust the loop and flash lengths independently before using the functions if necessary.
- To record the loop or flash effect, use the tape deck on this unit.

## Using the CD display

You can check the remaining time of the current track or that of the CD.

When a CD TEXT disc is loaded, you can check the information stored on the disc, such as the titles or artist names. When the unit detects CD TEXT discs, the “CD-TEXT” indication appears.

### Press DISPLAY.

During normal playback

Playing time on the current track →

Remaining time on the current track →

Remaining time on current CD (1 DISC mode)

or “-.-” display (ALL DISCS mode) → Title

name of the current track\* → Clock display

(for a few seconds) → Effect status

In the stop mode

When the CD player is in program mode and there is a program:

The last track number of the program and the total playing time → The last track number of

the current CD and the total playing time →

Clock display (for a few seconds) → Effect

status

In other conditions:

The current disc number → Disc title\* → The

artist information\* → Total number of tracks

and total playing time → Clock display (for a

few seconds) → Effect status

\* With CD TEXT discs only (certain characters cannot be displayed). When the CD contains more than 20 tracks, CD TEXT is not displayed from track 21 on.

Notes

- The display may not show all the characters depending on the disc.
- This player can only display the disc titles, track titles and artist names from CD TEXT discs. Other information cannot be displayed.

## Presetting radio stations

You can preset 20 stations for FM and 10 stations for AM.

### 1 Press TUNER/BAND repeatedly until the band you want appears.

Each time you press this button, the band changes as follows:

FM ↔ AM

### 2 Press TUNING MODE repeatedly until “AUTO” appears.

### 3 Press +/- until the frequency indication starts to change.

Scanning stops when the system tunes in a station. “TUNED” and “STEREO” (for a stereo program) appear.



### 4 Press TUNER MEMORY.

The next available preset number flashes in the display. The stations are stored from preset number 1.



### 5 Press ENTER.

“COMPLETE” appears and the station is stored.

### 6 Repeat steps 1 to 5 to store other stations.

To tune in a station with a weak signal

Press TUNING MODE repeatedly until “MANUAL” appears in step 2, then press +/- to tune in the station.

To set another station to the existing preset number

Start over from step 1. After step 4, press +/- to select the preset number you want to store for another station.

You can add a new preset number after the last preset number.

To erase the preset station

### 1 Hold down TUNER MEMORY until a preset number appears.

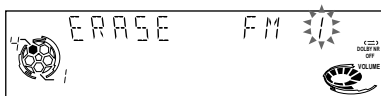

### 2 Press +/- to select the preset number you want to erase.

Select “ALL ERASE” when you want to erase all the preset stations.

### 3 Press ENTER.

“COMPLETE” appears.

When you erase a preset number, the preset number decreases by one and all preset numbers following the erased one are renumbered.

To change the AM tuning interval (Except for the European and Middle Eastern models)

The AM tuning interval is factory set to 9 kHz (10 kHz in some areas). To change the AM tuning interval, tune in any AM station first, then turn off the power. While holding down the ENTER button, turn the power back on. When you change the interval, AM preset stations will be erased. To reset the interval, repeat the same procedure.

Tip

The preset stations are retained for half a day even if you unplug the power cord or if a power failure occurs.

## Listening to the radio

### — Preset Tuning

Preset radio stations in the tuner's memory first (see “Presetting radio stations” on page 12).

- 1 Press **TUNER/BAND** repeatedly until the band you want appears.
- 2 Press **TUNING MODE** repeatedly until “PRESET” appears.  
Each time you press this button, the tuning mode changes cyclically as follows:  
MANUAL → AUTO → PRESET
- 3 Press **+/-** (or **PRESET +/-** on the remote) to tune in the preset station you want.

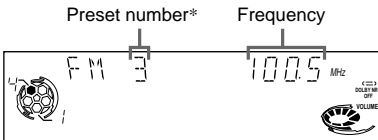

\* When only one station is preset, “ONE PRESET” appears.

To	Do this
Turn off the radio	Press I/⏻.
Adjust the volume	Turn VOLUME (or press VOL +/- on the remote).

To listen to non-preset radio stations  
Press **TUNING MODE** repeatedly in step 2 until “MANUAL” appears, then press **+/-** to tune in the desired station.

#### Tips

- When an FM program is noisy, press **STEREO/MONO** so that “MONO” appears. There will be no stereo effect, but the reception will improve.
- To improve broadcast reception, reorient the antennas.

## Using the Radio Data System (RDS)

(For European model only)

What is the Radio Data System?

Radio Data System (RDS) is a broadcasting service that allows radio stations to send additional information along with the regular program signal. This tuner offers convenient RDS features, such as station name display and location of stations by program type. RDS is available only on FM stations\*.

#### Note

RDS may not work properly if the station you are tuned to is not transmitting the RDS signal properly or if the signal strength is weak.

\* Not all FM stations provide RDS service, nor do they all provide the same types of services. If you are not familiar with the RDS system, check with your local radio stations for details on RDS services in your area.

## Receiving RDS broadcasts

Simply select a station from the FM band.

When you tune in a station that provides RDS services, the station name appears.

To check the RDS information

Each time you press **DISPLAY**, the display changes cyclically as follows:

Station name\* → Frequency → Program type\* → Clock display → Effect status

\* If the RDS broadcast is not received, the station name and program type may not appear in the display.

**continued**

## **Using the Radio Data System (RDS)**

### **(continued)**

#### Locating a station by program type (PTY)



You can locate a station you want by selecting a program type. The tuner tunes in the type of programs currently being broadcast from the RDS stations stored in the tuner's preset memory.

The types of programs include NEWS, AFFAIRS (current news), INFORMATION, SPORT, EDUCATION (education programs), DRAMA, CULTURE, SCIENCE, VARIED (interviews, games and comedy), POP, ROCK, EASY MUSIC (Easy listening), L.CLASSICAL (Classical music, such as instrumental, vocal, and choral works), S.CLASSICAL, OTHER MUSIC (music, such as rhythm and blues and reggae), WEATHER, FINANCE, CHILDREN, SOCIAL, RELIGION, PHONE IN, TRAVEL, LEISURE, JAZZ, COUNTRY (country music), NATION (nation's popular music), OLDIES, FOLK, DOCUMENTARY (investigative features), ALARM TEST (test signal for emergency broadcast), ALARM-ALARM (emergency broadcast), and NONE (any programs not defined above).

- 1 Press PTY while listening to the radio.**
- 2 Press +/- to select the program type you want.**
- 3 Press ENTER.**  
"SEARCH" and the selected program type are shown alternately in the display.  
When the tuner receives a program, the preset station number flashes.
- 4 Press +/- to continue searching for the station number you want.**
- 5 Press ENTER while the preset station number you want is flashing.**

To stop the search while it is in progress  
Press PTY.

## Loading a tape



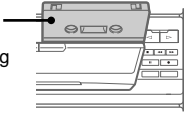

- 1 Press **A EJECT**  or **B EJECT** .
- 2 Insert a tape in deck A or B with the side you want to play facing forward.

Insert with the side you want to play/record facing forward.











## Playing a tape

You can play any type of tape. TYPE I (normal), TYPE II (CrO<sub>2</sub>), or TYPE IV (metal). The deck automatically detects the tape type.

- 1 Load a recorded tape.
- 2 Press **DIRECTION** repeatedly to select  to play one side. Select  to play both sides. Select **RELAY (Relay Play)\*** to play both decks in succession.
- 3 Press . Press  to play the reverse side. The tape starts playing.



\* Relay Play always follow this cyclic sequence:  
Deck A (front side) → Deck A (reverse side) →  
Deck B (front side) → Deck B (reverse side)

To	Do this
Stop play	Press  .
Pause (deck B only)	Press  . Press again to resume play.
Fast-forward	Press  or  in stop mode.
Rewind	Press  or  in stop mode.
Remove the cassette	Press <b>A EJECT</b>  (or <b>B EJECT</b>  .

### Tips

- The deck stops automatically after repeating the sequence five times.
- You can fast-forward or rewind the tape, regardless of the selected source.
- When you want to reduce the hiss noise in low-level high-frequency signals, press **DOLBY NR** so that “DOLBY NR B” appears.

Searching for the beginning of a track (AMS)

During playback, press  or  repeatedly for the number of songs you want to skip forward (or backward).

The search direction, + (forward) or - (back), and number of songs being skipped (1~9) appear.

Example: searching forward 2 songs

T A P E   A   : : : + 2

### Note

The AMS function may not operate correctly under the following circumstances:

- When the unrecorded space between songs is less than 4 seconds long.
- When the unit is placed near a television.

## Recording to a tape

### — CD Synchro Recording/High Speed Dubbing/Recording Manually/ Program Edit

You can record from a CD, tape or radio. You can use TYPE I (normal) or TYPE II (CrO<sub>2</sub>) tapes. The recording level is adjusted automatically.

Steps	Recording from a CD (CD Synchro Recording)	Recording from a tape (High-Speed Dubbing)	Recording Manually
1	Insert a recordable tape into deck B.		
2	Press <b>FUNCTION</b> repeatedly until “CD” appears.	Press <b>FUNCTION</b> repeatedly until “TAPE” appears.	Press <b>FUNCTION</b> or <b>TUNER/BAND</b> repeatedly until the source or band you want to record appears.
3	Insert the CD you want to record.	Insert the tape you want to record into deck A.	Insert the CD/tape, or tune to the station you want to record.
4	Press <b>CD SYNC.</b>	Press <b>H SPEED DUB.</b>	Press <b>● REC.</b>
	DECK B stands by for recording. To reduce the hiss noise in low level high frequency signals, press <b>DOLBY NR</b> so that “DOLBY NR B” appears in the display (except when recording from a tape).		
5	Press <b>DIRECTION</b> repeatedly to select $\rightleftarrows$ to record on one side. Select $\leftrightarrow$ (or <b>RELAY</b> ) to record on both sides.		
6	Press <b>II</b> . Recording starts.		
7			<b>Start playing the source to be recorded.</b>

To stop recording

Press **■**.

Tips

- When you want to record on the reverse side, press  $\triangleleft$  after pressing **● REC** so that the indicator on the  $\triangleleft$  button (for the reverse side) lights up green.
- When you record on both sides, be sure to start from the front side. If you start from the reverse side, recording stops at the end of the reverse side.
- For recording from the tape:  
If you set the direction to  $\leftrightarrow$  when the tapes you use have different lengths, the tapes in each deck reverses independently. If you select **RELAY**, the tapes in both decks reverse together.
- To record with the surround effect, press **SURROUND** so that “SUR (((((■))))))” appears. The equalizer settings will not be recorded.
- For recording from the radio:  
If noise is heard while recording from the radio, move the respective antenna to reduce the noise.



## Recording a CD by specifying track order

### — Program Edit

When programming, make sure the playing times for each side do not exceed the length of one side of the tape.

- 1 Load CDs and a recordable tape into deck B, then press **FUNCTION** repeatedly until “CD” appears.
- 2 Press **PLAY MODE** repeatedly until “PROGRAM” appears.
- 3 Select a CD and track by pressing **DISC SKIP** and turning the jog dial, then press **PLAY MODE** once.  
Repeat this procedure to program the remaining tracks for A side.
- 4 Press **II** on the remote to insert a pause at the end of side A.  
“P” appears and the total playing time resets to “0.00” in the display.
- 5 Repeat step 3 to program the remaining tracks to be recorded on side B.
- 6 Press **CD SYNC**.  
Deck B stands by for recording.
- 7 Press **DIRECTION** repeatedly to select  $\rightleftarrows$  to record on one side.  
Select  $\leftrightarrow$  (or **RELAY**) to record on both sides.
- 8 Press **II**.  
Recording starts.
- 9 Press **■** on the deck B and the CD player to stop recording.

#### Tip

To check the required tape length for recording a CD, press **EDIT** so that “EDIT” flashes after you have loaded a CD and switched function to CD. The required tape length for the currently selected CD appears, followed by the total playing time for side A and side B respectively (Tape Select Edit).

#### Notes

- You cannot use Tape Select Edit for discs containing over 20 tracks.
- You cannot use this function when Program Play mode has been set. After clearing the entire program, follow the above procedure.

## Timer-recording radio programs

To timer-record, you must preset the radio station (see “Presetting radio stations” on page 12) and set the clock (see “Setting the time” on page 8) beforehand.

- 1 Tune in the preset radio station (see “Listening to the radio” on page 13).
- 2 Press  $\odot$ /**CLOCK SET**.
- 3 Press  $\blacktriangle/\blacktriangledown$  repeatedly to select “REC,” then press **ENTER/NEXT**.  
“ON” appears and the hour indication flashes in the display.
- 4 Set the time to start recording.  
Press  $\blacktriangle/\blacktriangledown$  to set the hour, then press **ENTER/NEXT**.  
The minute indication starts flashing.  
Press  $\blacktriangle/\blacktriangledown$  to set the minute, then press **ENTER/NEXT**.  
The hour indication flashes again.
- 5 Set the time to stop recording following the above procedure.  
The start time appears, followed by the stop time, the preset radio station to be recorded (e.g., “TUNER FM 5”), then the original display appears.
- 6 Insert a recordable tape into deck B.
- 7 Turn off the power.  
When the recording starts, the volume level is set to the minimum.

To	Do this
Check the setting	Press <b>TIMER SELECT</b> . Press $\blacktriangle/\blacktriangledown$ to select “SEL REC.” Then, press <b>ENTER/NEXT</b> . To change the setting, start over from step 1.
Cancel timer operation	Press <b>TIMER SELECT</b> . Press $\blacktriangle/\blacktriangledown$ to select “TIMER OFF.” Then, press <b>ENTER/NEXT</b> .

#### Notes

- The system turns on 15 seconds before the preset time.
- If the system is on at the preset time, the Timer recording will not be made.
- When you use the Sleep Timer, Daily Timer and Timer recording will not turn on the system until the Sleep Timer turns it off.
- Recording starts from the front side.

## Adjusting the sound

To reinforce lower bass sound (SUPER WOOFER)

Press SUPER WOOFER.

Each time you press this button, the super woofer level display changes cyclically as follows:

SUPER WOOFER FLAT → LOW → HIGH

To select the super woofer mode

Press SUPER WOOFER MODE while the super woofer is on.

Each time you press this button, the super woofer mode display changes as follows:

MODE MOVIE ↔ MODE MUSIC

For a powerful sound (GROOVE)

Press GROOVE.

The volume switches to power mode, the equalizer curve changes, and the indicator on the GROOVE button lights up.

Press GROOVE again to return to the previous volume.

Note

Canceling the Groove mode cancels the equalizer curve and super woofer level. Adjust the equalizer settings to obtain the desired effect.

## Selecting the audio emphasis effect

Selecting the preset effect from the music menu

Press DIRECT EQUALIZER button you want.

The preset effect name appears.

See the chart “Music menu options.”

To	Press
Select USER FILE	P.FILE
Cancel the effect	FLAT (or FILE SELECT ON/OFF on the remote).

Music menu options

“SUR(■■■■■)” appears if you select an effect with surround effects.

Effect	For
SALSA	standard music sources
REGGAE	
SAMBA	
TANGO	
MOVIE	
DANCE	
JAZZ	soundtracks and special listening situations
ROCK	
GAME	
GUITAR	

## Selecting the surround effect

Press SURROUND.

Every time you press the button, the display changes as follows:

SURROUND ON (SUR(■■■■■))



SURROUND OFF

# Making a personal audio emphasis file

## — *Personal File*

You can create personal files of audio patterns (surround effect and graphic equalizer) and store them in the system's memory. Later, you can call up an audio pattern when playing a favorite tape, CD, or radio program. Before operating, first select the basic audio emphasis you want for your sound.

- 1 Press ◀/▶ to select the frequencies, then press ▲/▼ to adjust the level.

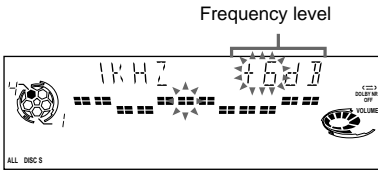

- 2 Press ENTER/NEXT.

This setting is automatically stored as P.FILE.

Any settings previously stored at this memory location are erased and replaced by the new settings.

To call up the personal file

Press P.FILE.

Tip

If you choose another audio emphasis, the adjusted sound effect is lost. To retain the adjusted sound effect, press P.FILE.

## Changing the spectrum analyzer display

### Press SPECTRUM ANALYZER.

Each time you press the button, the display changes cyclically as follows:

IMAGE ILLUMINATION → IMAGE →  
NORMAL ILLUMINATION → NORMAL

## Singing along: Karaoke

You can sing along with any stereo CD or tape by turning down the singer's voice. You need to connect an optional microphone.

- 1 Turn **MIC LEVEL** to **MIN** to turn down the microphone control level.
- 2 Connect an optional microphone to **MIX MIC**.
- 3 Press **MIX GUITAR/KARAOKE**.  
Each time you press the button, the display changes as follows:  
MIX GUITAR/KARAOKE ↔ OFF or audio emphasis name  
The  indicator appears when karaoke mode is activated.  
To sing karaoke by decreasing the vocal level of a CD or TAPE, select "MIX GUITAR/KARAOKE."
- 4 Start playing the music and adjust the volume.
- 5 Adjust the microphone volume by turning **MIC LEVEL**.



After you have finished

Turn **MIC LEVEL** to **MIN** and disconnect the microphone from **MIX MIC**, then press **MIX GUITAR/KARAOKE** repeatedly until "" disappears.

### Notes

- With some songs, vocals may not be canceled when you select "MIX GUITAR/KARAOKE."
- During MIX GUITAR/KARAOKE, equalizer and surround settings cannot be changed.
- If you select a sound effect, the karaoke mode is canceled.
- The instrumental sound may be reduced as well as the singer's voice when the sound is recorded in monaural.
- The singer's voice may not be reduced when:
  - only a few instruments are playing.
  - a duet is being played.
  - the source has strong echoes or chorus.
  - the singer's voice deviates from the center.
  - the voice on the source is singing in high soprano or tenor.

## Mixing and recording sound

- 1 Do the procedure for "Singing along" (steps 1 through 5). Then, load a recordable tape in deck B.
- 2 Press **FUNCTION** repeatedly to select the source you desire and set it to pause mode.
- 3 Press **● REC**.
- 4 Press **DIRECTION** repeatedly to select  to record on one side. Select  (or **RELAY**) to record on both sides.
- 5 Press **II**.
- 6 Press **▷ II** to start playing the CD (or **▷** on deck A to start playing the tape).  
Start singing along with the music.

To stop recording

Press **■**.

### Tips

- If acoustic feedback (howling) occurs, move the microphone away from the speakers or change the direction of the microphone.
- If you want to record your voice through the microphone only, you can do so by selecting the CD function and not playing a CD.
- When high level sound signals are input, the unit automatically adjusts the recording level to prevent distortion of the recorded sound signal (Auto Level Control Function).

## Playing a guitar

You can enjoy playing the guitar by connecting an electric guitar to the GUITAR jack on the front panel.

When you select “MIX GUITAR/KARAOKE” by pressing MIX GUITAR/KARAOKE, you can play along with any stereo CD or tape.

You can select your preferred sound characteristics by adjusting the GUITAR LEVEL.

### Using the Guitar distortion effect

#### Press GUITAR DISTORTION.

The indicator on the GUITAR DISTORTION button lights up.

Once GUITAR DISTORTION is activated, it will remain active while the power is on even if the function is changed.

To turn off GUITAR DISTORTION, press GUITAR DISTORTION again, the indicator on this button goes off.

#### Note

Playing a guitar with this unit may cause distortion or howling. To avoid this, do the followings:

- Move the guitar away from the speakers.
- Turn down the guitar volume.

## Enhancing video game sound

### — *Game Sync*

You can enjoy the sound effect of video games.

- 1 **Connect a video game player** (see “Connecting MD deck/VCR/camcorder/video game” on page 23).
- 2 **Press GAME at the right side corner on the front panel** (see [11](#), “Parts Identification” on page 4) .

## Falling asleep to music

### — *Sleep Timer*

You can have the system turn off at a preset time, so you can fall asleep to music.

#### Press SLEEP.

Each time you press the button, the minute display (the turn-off time) changes as follows:

AUTO → 90 → 80 → 70 → ... → 10 → OFF → AUTO\* ...

\* The power turns off when the current CD or tape finishes playback (for up to 100 minutes).

To	Press
Check the remaining time	SLEEP once.
Change the time to turn off	SLEEP to select the time you want.
Cancel the Sleep Timer function	SLEEP repeatedly until “SLEEP OFF” appears.

# Waking up to music

## — Daily Timer

You can wake up to music at a preset time every day. Make sure you have set the clock (see “Setting the time” on page 8).

### 1 Prepare the music source you want to play.

- CD: Load a CD. To start from a specific track, make a program (see “Programming the CD tracks” on page 10).
- Tape: Load a tape with the side you want to play facing forward.
- Radio: Tune in the preset station you want (see “Presetting radio stations” on page 12).

### 2 Adjust the volume.

### 3 Press $\odot$ /CLOCK SET.

“SET” appears and “DAILY” flashes in the display.

### 4 Press $\blacktriangle/\blacktriangledown$ repeatedly to select “DAILY,” then press ENTER/NEXT.

“ON” appears and the hour digits flash in the display.

### 5 Set the time to start playback.

Press  $\blacktriangle/\blacktriangledown$  repeatedly to set the hour, then press ENTER/NEXT.

The minute indication starts flashing.

Press  $\blacktriangle/\blacktriangledown$  repeatedly to set the minute, then press ENTER/NEXT.

The hour indication flashes again.

### 6 Set the time to stop playback following the above procedure.

### 7 Press $\blacktriangle/\blacktriangledown$ repeatedly until the music source you want appears.

The indication changes as follows:

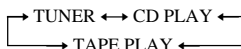

### 8 Press ENTER/NEXT.

The start time, stop time, and the music source appear, then the original display appears.

### 9 Turn off the power.

To	Do this
Check the setting	Press TIMER SELECT and then press $\blacktriangle/\blacktriangledown$ to select “DAILY,” then press ENTER/NEXT.
Change the setting	Start from step 1.
Cancel the timer operation	Press TIMER SELECT and then $\blacktriangle/\blacktriangledown$ to select “OFF,” then press ENTER/NEXT.

#### Note

When you use the Sleep Timer, Daily Timer and Timer recording will not turn on the system until the Sleep Timer turns it off.

#### Tip

The power turns on 15 seconds before the preset time.

## Connecting MD deck/VCR/ camcorder/video game

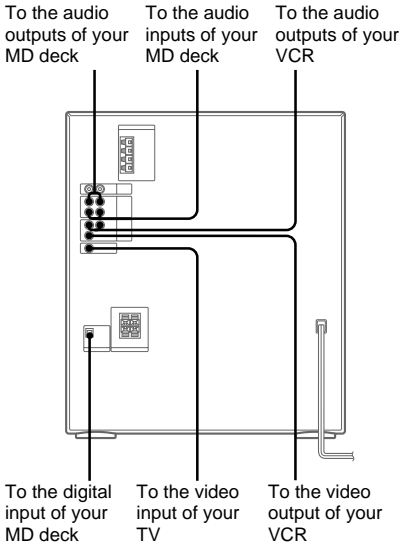

To	Do This
Make a digital recording from CD to MD	Connect the optical cable.
Listen to the connected MD deck	Press FUNCTION repeatedly until "MD" appears.
Listen to the connected VCR	Press FUNCTION repeatedly until "VIDEO" appears.
Listen to the sound from the connected camcorder or video game	Press FUNCTION repeatedly until "GAME" appears or press GAME at the right side corner on the front panel.

### Notes

- If sound is distorted when you connect your VCR to the VCR input jack of the unit, connect your VCR to the MD input jack instead.
- Be sure to match the color of the plugs and the connectors.

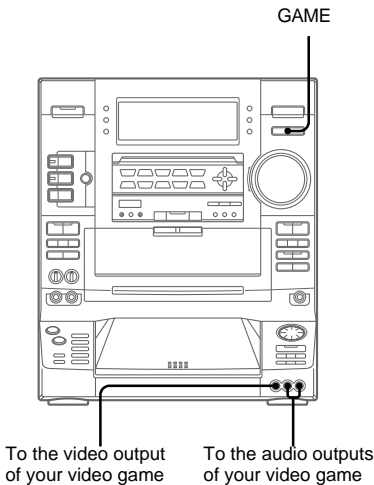

## Connecting a turntable/ mixer

(mixer for European, North American, and Mexican models only)

To the outputs of your mixer    To the inputs of your mixer    To the audio outputs of your turntable

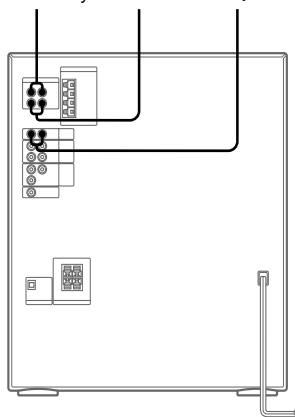

### Tips

You can also record the sound produced by the mixer onto a tape.

### Notes

- Using a turntable at high volume may cause distortion or howling. This is often caused by the bass sound from the speakers. The bass sound may produce the distortion or howling. To avoid this, do the following:
  - 1 Keep some distance from speakers and the turntable.
  - 2 Stop using the surround effect.
  - 3 Install the speakers or the turntable on a firm and stable surface.
  - 4 Press SUPER WOOFER repeatedly until the indicator on this button goes off.
- Replace the jumpers when the mixer is not in use. Otherwise, no sound will be heard. Be sure to connect the jumpers from the RETURN jack to the SEND jack of the unit. Two jumpers are pre-installed connecting the DJ MIX RETURN and SEND jacks.

To	Do This
Listen to the connected turntable	Press FUNCTION repeatedly until "PHONO" appears.
Listen to the connected mixer	<ol style="list-style-type: none"> <li>1 Remove the jumper from the unit.</li> <li>2 Connect the SEND jack of the unit to the IN jack of the mixer with an optional cable.</li> <li>3 Connect the RETURN jack of the unit to the OUT jack of the mixer with an optional cable.</li> <li>4 Press FUNCTION repeatedly until "CD" appears.</li> </ol>



## Precautions

### On operating voltage

Before operating the unit, check that the operating voltage of your unit is identical with the voltage of your local power supply.

### On safety

- The unit is not disconnected from the AC power source (mains) as long as it is connected to the wall outlet, even if the unit itself has been turned off.
- Unplug the unit from the wall outlet (mains) if it is not to be used for an extended period of time. To disconnect the cord (mains lead), pull it out by the plug. Never pull the cord itself.
- Should any solid object or liquid fall into the component, unplug the unit and have the component checked by qualified personnel before operating it any further.
- The AC power cord must be changed only at the qualified service shop.

### On placement

- Do not place the unit in an inclined position.
- Do not place the unit in locations where it is:
  - extremely hot or cold
  - dusty or dirty
  - very humid
  - vibrating
  - subject to direct sunlight

### On heat buildup

- Although the unit heats up during the operation, this is not the malfunction.
- Place the unit in a location with adequate ventilation to prevent heat build-up in the unit.

If you continuously use this unit at a large volume, the cabinet temperature of the top, side and bottom rises considerably. To avoid burning yourself, do not touch the cabinet.

To prevent a malfunction, do not cover the ventilation hole for cooling fan.

### On operation

- If the unit is brought directly from a cold to a warm location, or is placed in a very damp room, moisture may condense on the lens inside the CD player. Should this occur, the unit will not operate properly. Remove the CD and leave the unit turned on for about an hour until the moisture evaporates.
- When you move the unit, take out any discs.

If you have any questions or problems concerning your unit, please consult your nearest Sony dealer.

### Notes on CDs

- Before playing, clean the CD with a cleaning cloth. Wipe the CD from the center out.
- Do not use solvents.
- Do not expose the CD to direct sunlight or heat sources.

- Discs with non- standard shapes (e.g., heart, square, star) cannot be played on this unit. Do not use such discs.

### Cleaning the cabinet

Use a soft cloth slightly moistened with mild detergent solution.

### To save a tape permanently

To prevent a tape from being accidentally recorded over, break off the cassette tab from side A or B as illustrated.

If you later want to reuse the tape for recording, cover the broken tab with adhesive tape. However, be careful not to cover the detector slots which allow the tape player to automatically detect the type of tape.

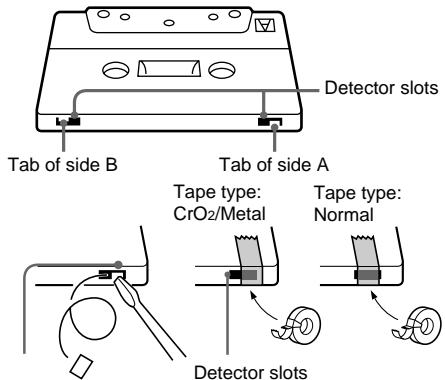

Break off the cassette tab of side A

### Before placing a cassette in the tape deck

Take up any slack in the tape. Otherwise the tape may get entangled in the parts of the tape deck and become damaged.

### When using a tape longer than 90 minutes

The tape is very elastic. Do not change the tape operations such as play, stop, and fast-winding, etc. frequently. The tape may get entangled in the tape deck.

### Cleaning the tape heads

Clean the tape heads after every 10 hours of use. Make sure to clean the tape heads before you start an important recording or after playing an old tape. Use separately sold dry-type or wet-type cleaning cassette. For details, refer to the instructions of the cleaning cassette.

### Demagnetizing the tape heads

Demagnetize the tape heads and the metal parts that have contact with the tape every 20 to 30 hours of use with a separately sold demagnetizing cassette. For details, refer to the instructions of the demagnetizing cassette.

# Troubleshooting

If you run into any problem using this unit, use the following check list.

First, check that the power cord is connected firmly and the speakers are connected correctly and firmly.

Should any problem persist, consult your nearest Sony dealer.

## General

---

**The display starts flashing as soon as you plug in the power cord even though you haven't turned on the power.**

- Refer to demonstration (see page 7, step 4).

---

**The clock setting is canceled.**

- The power cord is disconnected or a power failure occurs. Redo "Setting the time" (on page 8). If you have set the timer, redo "Waking up to music" (on page 22) and "Timer-recording radio programs" (on page 17).

---

**The radio presetting/timer setting is canceled.**

- The power cord is disconnected or a power failure occurs for longer than half a day. Redo "Presetting radio stations" (on page 12).

---

**There is no sound.**

- The jumpers for the DJ MIX jacks are not connected (for European, North American, and Mexican models only).
- Turn VOLUME clockwise.
- The headphones are connected.
- Insert only the stripped portion of the speaker cord into the SPEAKER jack. Inserting the vinyl portion of the speaker cord will obstruct the speaker connections.
- The protective device on the amplifier has been activated because of a short circuit. ("PROTECT" and "PUSH POWER" flash alternately.) Turn off the unit, eliminate the short-circuit problem and turn on the power again.
- There is no audio output during timer recording.

---

**There is no microphone sound.**

- Turn VOLUME or MIC LEVEL to adjust the microphone volume.
  - Make sure the microphone is connected to the MIX MIC jack correctly.
- 

---

**There is no guitar sound.**

- Turn VOLUME or GUITAR LEVEL to adjust the guitar volume.
- Make sure the guitar is connected to the GUITAR jack correctly.
- Select "MIX GUITAR/KARAOKE" by pressing MIX GUITAR/KARAOKE.

---

**There is severe hum or noise.**

- A TV or VCR is placed too close to the stereo system. Move the stereo system away from the TV or VCR.

---

**"0:00" (or "12:00 AM") flashes in the display.**

- A power interruption occurred. Set the clock and timer settings again.

---

**The timer does not function.**

- Set the clock correctly.

---

**DAILY and REC do not appear when you press the /CLOCK SET button.**

- Set the timer correctly.
- Set the clock.

---

**The remote does not function.**

- There is an obstacle between the remote and the system.
- The remote is not pointing in the direction of the system's sensor.
- The batteries have run down. Replace the batteries.

---

**There is acoustic feedback.**

- Decrease the volume level.
- Move the microphone away from the speakers or change the direction of the microphone.

---

**The color irregularity on a TV screen persists.**

- Turn off the TV set once, then turn it on after 15 to 30 minutes. If the color irregularity still persists, place the speakers farther away from the TV set.
-

## Speakers

---

**“PROTECT” and “PUSH POWER” appear alternately.**

- A strong signal was input. Press I/⏻ to turn off the power, leave the system turned off for a while, then press I/⏻ again to turn on the power.
- Check the speaker cables in case “PROTECT” and “PUSH POWER” appear alternately again after you turn the system on.

**Sound comes from one channel or unbalanced left and right volume.**

- Check the speaker connection and speaker placement.

## CD Player

---

**The CD tray does not close.**

- The CD is not placed properly.

**The CD will not play.**

- The CD is not lying flat in the disc tray.
- The CD is dirty (see “Notes on CDs” on page 25).
- The CD is inserted label side down.
- The CD is moist.

**Play does not start from the first track.**

- The player is in program or shuffle mode. Press PLAY MODE repeatedly until “PROGRAM,” “ALL DISCS SHUFFLE,” or “1 DISC SHUFFLE” disappears.

## Tape Deck

---

**The tape does not record.**

- The tab has been removed from the cassette (see “To save a tape permanently” on page 25).
- The tape has reeled to the end.

**The tape does not record nor play, or there is a decrease in sound level.**

- The heads are dirty (see “Cleaning the tape heads” on page 25).
- The record/playback heads are magnetized (see “Demagnetizing the tape heads” on page 25).

**The tape does not erase completely.**

- The record/playback heads are magnetized (see “Demagnetizing the tape heads” on page 25).

---

**There is excessive wow or flutter, or the sound drops out.**

- The capstans or pinch rollers are dirty (see “Cleaning the tape heads” on page 25).

**Noise increases or the high frequencies are erased.**

- The record/playback heads are magnetized (see “Demagnetizing the tape heads” on page 25).

## Tuner

---

**Severe hum or noise (“TUNED” or “STEREO” flashes in the display).**

- Adjust the antenna.
- The signal strength is too weak. Connect the external antenna.

**A stereo FM program cannot be received in stereo.**

- Press STEREO/MONO so that “STEREO” disappears.

If other troubles not described above occur, reset the system as follows:

- 1** Press ⏻/CLOCK SET, ENTER/NEXT and I/⏻ at the same time.
- 2** Unplug the power cord.
- 3** Plug the power cord back in.
- 4** Press I/⏻ to turn on the power.

The unit is reset to factory settings. All the settings you made are cleared.

# Specifications

AUDIO POWER SPECIFICATIONS:  
(LBT-XG500 USA models only)

## POWER OUTPUT AND TOTAL HARMONIC DISTORTION

With 6 ohm loads both channels driven, from 120-10,000 Hz; rates 140 watts per channel minimum RMS power, with no more than 10% total harmonic distortion.

### Amplifier section

#### Canadian model:

##### LBT-XG500

Continuous RMS power output (reference)  
160 + 160 watts (6 ohms at 1 kHz, 10% THD)  
Total harmonic distortion less than 0.07%  
(6 ohms at 1 kHz, 70 W)

#### European model:

##### LBT-XG700

DIN power output (rated) 200 + 200 watts  
(6 ohms at 1 kHz, DIN)  
Continuous RMS power output (reference)  
250 + 250 watts  
(6 ohms at 1 kHz, 10% THD)  
Music power output (reference)  
430 + 430 watts  
(6 ohms at 1 kHz, 10% THD)

##### LBT-XG500

DIN power output (rated) 110 + 110 watts  
(6 ohms at 1 kHz, DIN)  
Continuous RMS power output (reference)  
140 + 140 watts  
(6 ohms at 1 kHz, 10% THD)  
Music power output (reference)  
240 + 240 watts  
(6 ohms at 1 kHz, 10% THD)

#### Other models:

##### LBT-XG80

The following measured at AC 120/220/240V, 50 Hz  
DIN power output (rated) 240 + 240 watts  
(4 ohms at 1 kHz, DIN)  
Continuous RMS power output (reference)  
320 + 320 watts  
(4 ohms at 1 kHz, 10% THD)

##### LBT-XG60

The following measured at AC 120/220/240V, 50 Hz  
DIN power output (rated) 150 + 150 watts  
(6 ohms at 1 kHz, DIN)  
Continuous RMS power output (reference)  
200 + 200 watts  
(6 ohms at 1 kHz, 10% THD)

### Inputs

DJ MIX\*: (phono jacks) sensitivity 250 mV, impedance 47 kilohms  
GUITAR IN: (phone jack) sensitivity 75 mV, impedance 470 kilohms  
PHONO IN: (phono jacks) sensitivity 3 mV, impedance 47 kilohms  
MIX MIC: (phone jack) sensitivity 1 mV, impedance 10 kilohms  
VIDEO IN: (phono jacks) sensitivity 250 mV, impedance 47 kilohms  
GAME IN: (phono jacks) sensitivity 250 mV, impedance 47 kilohms  
MD IN: (phono jack) sensitivity 450 mV, impedance 47 kilohms

### Outputs

DJ MIX\*: (phono jacks) sensitivity 250 mV, impedance 1 kilohms  
PHONES: (stereo phone jack) accepts headphones of 8 ohms or more  
VIDEO OUT: (phono jack) voltage 250 mV, impedance 1 kilohm  
MD OUT: (phono jacks) voltage 250 mV, impedance 1 kilohm  
FRONT SPEAKER:  
LBT-XG80: accepts impedance of 4 to 16 ohms  
LBT-XG700/XG500/XG60: accepts impedance of 6 to 16 ohms

\* European, North American, and Mexican models only

## CD player section

System	Compact disc and digital audio system
Laser	Semiconductor laser ( $\lambda=780\text{nm}$ ), Emission duration: continuous
Wavelength	780 – 790 nm
Frequency response	2 Hz – 20 kHz ( $\pm 0.5$ dB)
Signal-to-noise ratio	More than 90 dB
Dynamic range	More than 90 dB
CD OPTICAL DIGITAL OUT (Square optical connector jack, rear panel)	
Wavelength:	660 nm
Output level	–18 dBm

## Tape player section

Recording system	4-track 2-channel stereo
Frequency response (DOLBY NR OFF)	40 – 13,000 Hz ( $\pm 3$ dB), using Sony TYPE I cassette
	40 – 14,000 Hz ( $\pm 3$ dB), using Sony TYPE II cassette
Wow and flutter	$\pm 0.15\%$ W.Peak (IEC) 0.1% W.RMS (NAB) $\pm 0.2\%$ W.Peak (DIN)

## Tuner section

FM stereo, FM/AM superheterodyne tuner

### FM tuner section

Tuning range	
North American models:	87.5 – 108.0 MHz (100 kHz step)
Other models:	87.5 – 108.0 MHz (50 kHz step)
Antenna	FM lead antenna
Antenna terminals	75 ohm unbalanced
Intermediate frequency	10.7 MHz

### AM tuner section

Tuning range	
Pan- American models:	530 – 1,710 kHz (with the interval set at 10 kHz)
	531 – 1,710 kHz (with the interval set at 9 kHz)
European and Middle Eastern models:	531 – 1,602 kHz (with the interval set at 9 kHz)
Other models:	531 – 1,602 kHz (with the interval set at 9 kHz)
	530 – 1,710 kHz (with the interval set at 10 kHz)
Antenna	AM loop antenna
Antenna terminals	External antenna terminal
Intermediate frequency	450 kHz

## Speakers

### North American and European models: SS-XG500 for LBT-XG500

Speaker system	3-way BUILT IN SW, bass-reflex type
Speaker units	
Super Woofer/Woofer:	17 cm/17 cm, cone type
Tweeter:	2.5 cm, horn type
Rated impedance	6 ohms
Dimensions (w/h/d)	Approx. 255 × 530 × 330 mm (North American model)
	Approx. 255 × 530 × 375 mm (European model)
Mass	Approx. 9 kg net per speaker (North American model)
	Approx. 10 kg net per speaker (European model)

### Other models speaker SS-XG60 for LBT-XG60

Speaker system	3-way BUILT IN SW, bass-reflex type, magnetically shielded type
Speaker units	
Super Woofer/Woofer:	17 cm/17 cm, cone type
Tweeter:	2.5 cm, horn type
Rated impedance	6 ohms
Dimensions (w/h/d)	Approx. 255 × 530 × 375 mm
Mass	Approx. 10 kg net per speaker

### SS-XG700/XG80 for LBT-XG700/XG80

Speaker system	3-way BUILT IN SW, bass-reflex type, magnetically shielded type
Speaker units	
Super Woofer:	22 cm, cone type
Woofer:	20 cm, cone type
Tweeter:	2.5 cm, horn type
Rated impedance	
SS-XG80	4 ohms
SS-XG700	6 ohms
Dimensions (w/h/d)	Approx. 290 × 615 × 435 mm
Mass	Approx. 16 kg net per speaker

continued

## **Specifications (continued)**

### General

#### Power requirements

North American models:	120 V AC, 60 Hz
European models:	230 V AC, 50/60 Hz
Mexican model:	120 V AC, 50/60 Hz
Australian model:	230 – 240 V AC, 50/60 Hz
Other models:	120 V, 220 V or 230 – 240 V AC, 50/60 Hz Adjustable with voltage selector

#### Power consumption

##### U.S.A. models:

LBT-XG500 240 watts

##### Canadian model:

LBT-XG500 320 VA

##### European models:

LBT-XG700 220 watts  
0.6 watts (at the power saving mode)

LBT-XG500 220 watts  
0.6 watts (at the power saving mode)

##### Other models:

LBT-XG80 300 watts

LBT-XG60 180 watts

Dimensions (w/h/d) Approx. 355 x 425 x 450 mm

##### Mass :

LBT-XG700 Approx. 15.5 kg

LBT-XG500 Approx. 13.5 kg

LBT-XG80 Approx. 16.0 kg

LBT-XG60 Approx. 15.0 kg

Supplied accessories: AM loop antenna (1)  
FM lead antenna (1)  
Speaker cords (2)  
Speaker pads (8)  
Remote commander (1)  
Batteries (2)

Design and specifications are subject to change without notice.



