

PARTS LIST

Vacuum Cleaner

SC-A114 (U.S.A.)

Specifications

Power source	: AC 120 V 50 Hz
Power consumption	: 11 A
Motor revolution	: 36,000 r.p.m.
Vacuum	: 23,000 Pa
Dimensions	: 13 - 3/8" x 12 - 31/32" x 42 - 1/8"
L X W X H	(340 x 330 x 1,070 mm)
Net weight	: 15 lbs. 3 ozs. (6.9 Kg)
Attachment	: Suction hose, 2 Wands, Crevice tool, Upholstery tool

PRODUCT CODE NO.

1 - 326 734 51 (L)

Wiring Diagram

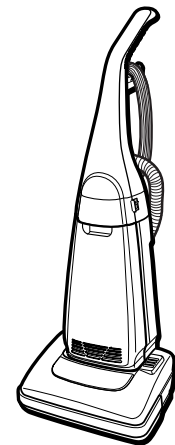
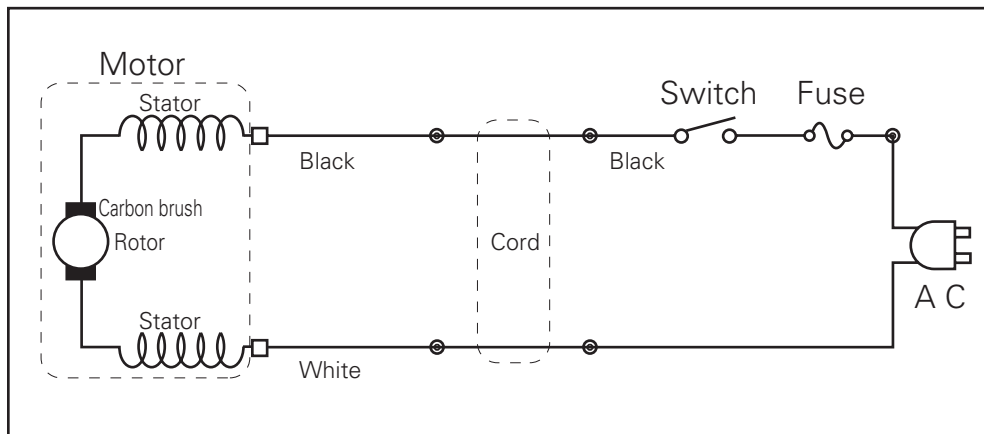

Exploded View

NOTE: The parts marked with \triangle have special characteristics of safety, if replace the \triangle mark parts, use only SANYO specified parts.

SC-A114 (U.S.A.)

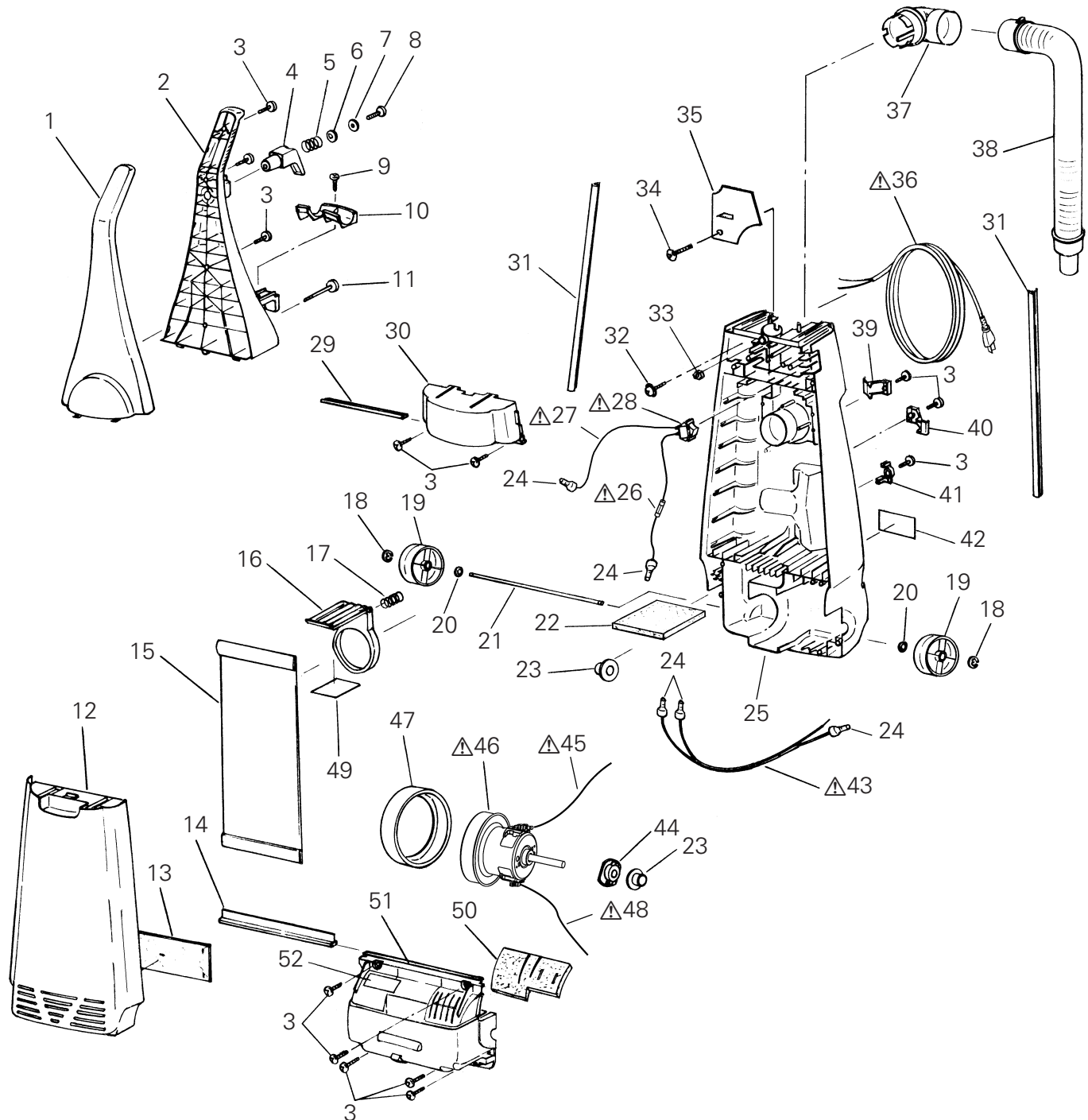

Exploded View



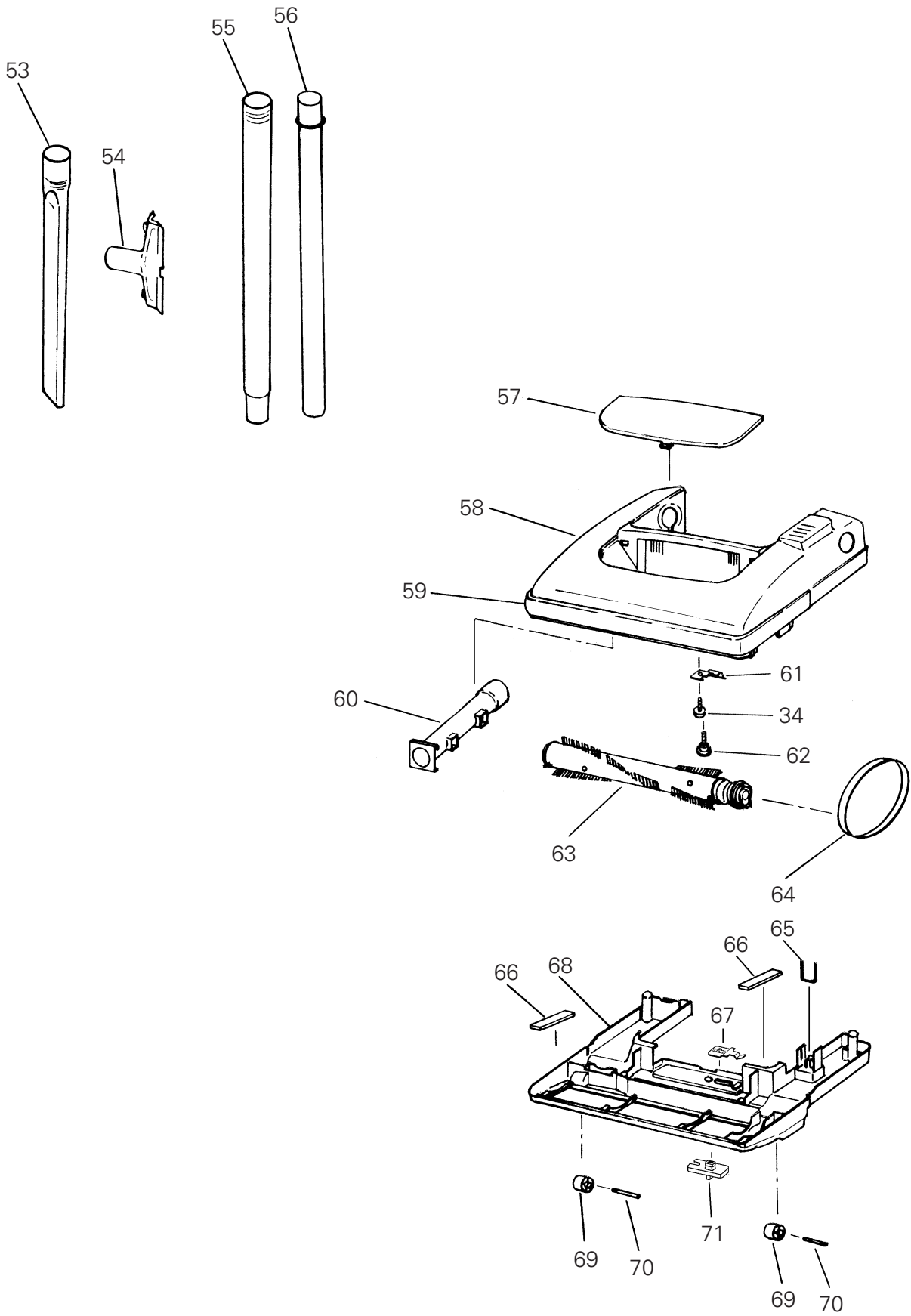





SC-A114 (U.S.A.)



Parts List

NOTE: The parts marked with  have special characteristics of safety,
if replace the  mark parts, use only SANYO specified parts.

SC-A114 (U.S.A.)

Key No.	Parts No.	Description	Q'ty	Key No.	Parts No.	Description	Q'ty
1	663 000 1974	GRIP FRONT (B-437)	1	50	663 000 2452	OUTLET FILTER INNER	1
2	663 000 1981	GRIP REAR (NN-B)	1	51	663 000 2469	CASE FRONT (B-437)	1
3	663 000 1998	SCREW (4X20)	13	52	663 000 2674	CAUTION LABEL	1
4	663 000 2001	CORD HOOK (NN-B)	1	53	663 000 2476	CREVICE TOOL (NN-B)	1
5	663 000 2018	HELICAL SPRING B	1	54	663 000 2483	UPHOLSTERY BRUSH BASE	1
6	663 000 2025	WASHER Y 8.2X12X1.5	1	55	663 000 2490	CONNECTION PIPE A (NN-B)	1
7	411 093 1308	WASHER Z 4X12X0.8	1	56	663 000 2506	CONNECTION PIPE B (NN-B)	1
8	663 000 2032	SCREW (4X33)	1	57	663 000 2513	LENS (B-437)	1
9	663 000 2049	SCREW (4X12)	1	58	663 000 2520	CASE UPPER (B-437)	1
10	663 000 2056	GRIP INSCRIPTION (NN-B)	1	59	663 000 2537	BUMPER	1
11	663 000 2063	HANDLE SCREW (M6)	1	60	663 000 2544	AIR INLET	1
12	663 000 2070	DUST BOX COVER (B-437)	1	61	663 000 2551	LEAF SPRING	1
13	663 000 2087	OUTLET FILTER OUTER	1	62	663 000 2568	SCREW	1
14	663 000 2094	DUST BOX PACKING A	1	63	663 000 2575	ROTARY BRUSH COMP.	1
15	663 000 2100	PAPER FILTER ASSEMBLY	1	64	663 000 2582	BELT	1
16	663 000 2117	CRUMP LEVER (NW-13)	1	65	663 000 2599	BELT COVER D	1
17	663 000 2124	HELICAL SPRING A	1	66	663 000 2605	AIR SPREADER B	2
18	663 000 2131	RING E6	2	67	663 000 2612	LEAF SPRING D	1
19	663 000 2148	WHEEL REAR (NN-B)	2	68	663 000 2629	BOTTOM PLATE (NN-B)	1
20	663 000 2155	WASHER Z 7.2X12X0.5	2	69	663 000 2636	WHEEL FRONT	2
21	663 000 2162	SHAFT	1	70	663 000 2643	SHAFT FRONT	2
22	663 000 2179	AIR INLET FILTER	1	71	663 000 2650	LEVER	1
23	663 000 2186	SLEEVE (NN-B)	2		663 000 2667	INSTRUCTION MANUAL	1
24	663 000 2193	WIRE CONNECTOR (CE-530)	5				
25	663 000 2209	CASE REAR (NN-B)	1				
 26	663 000 2216	FUSE ASSEMBLY (125V 12A)	1				
 27	663 000 2223	CORD ASSEMBLY (BLACK) L=120	1				
 28	663 000 2230	SWITCH	1				
29	663 000 2247	DUST BOX PACKING B	1				
30	663 000 2254	CASE COVER (B-437)	1				
31	663 000 2261	DUST BOX PACKING C	2				
32	663 000 2278	SCREW (4X17)	1				
33	663 000 2285	NUT	1				
34	663 000 2292	SCREW (4X14)	2				
35	663 000 2308	SHIELD PLATE B	1				
 36	663 000 2315	POWER CORD (U2)	1				
37	663 000 2322	HOSE JOINT PIPE A	1				
38	663 000 2339	SUCTION HOSE COMP.	1				
39	663 000 2346	ATTACHMENT SUPPORTER B	1				
40	663 000 2353	ATTACHMENT SUPPORTER D	1				
41	663 000 2360	ATTACHMENT SUPPORTER A	1				
42	663 000 2377	NAME PLATE	1				
 43	663 000 2384	CORD ASSEMBLY	1				
44	663 000 2391	MOTOR CUSHION REAR	1				
 45	663 000 2407	CORD ASSEMBLY (BLACK) L=350	1				
 46	663 000 2414	MOTOR COMP. (AC 120 V)	1				
 47	663 000 0298	CARBON BRUSH ASSEMBLY	2				
47	663 000 2421	MOTOR CUSHION FRONT	1				
 48	663 000 2438	CORD ASSEMBLY (WHITE) L=350	1				
49	663 000 2445	CAUTION LABEL	1				

COLOR CODE: B-437(BLUE), NW-13(GRAY), NN-B(BLACK)

For Parts or Service Contact
SANYO FISHER SERVICE CORPORATION.
21605 Plummer Street,
Chatsworth, CA 91311