

# PXI

---

## NI 8171 Series User Manual

## **Worldwide Technical Support and Product Information**

ni.com

### **National Instruments Corporate Headquarters**

11500 North Mopac Expressway Austin, Texas 78759-3504 USA Tel: 512 794 0100

### **Worldwide Offices**

Australia 03 9879 5166, Austria 0662 45 79 90 0, Belgium 02 757 00 20, Brazil 011 284 5011,  
Canada (Calgary) 403 274 9391, Canada (Montreal) 514 288 5722, Canada (Ottawa) 613 233 5949,  
Canada (Québec) 514 694 8521, Canada (Toronto) 905 785 0085, China (Shanghai) 021 6555 7838,  
China (ShenZhen) 0755 3904939, Denmark 45 76 26 00, Finland 09 725 725 11, France 01 48 14 24 24,  
Germany 089 741 31 30, Greece 30 1 42 96 427, Hong Kong 2645 3186, India 91805275406,  
Israel 03 6120092, Italy 02 413091, Japan 03 5472 2970, Korea 02 596 7456, Malaysia 603 9596711,  
Mexico 5 280 7625, Netherlands 0348 433466, New Zealand 09 914 0488, Norway 32 27 73 00,  
Poland 0 22 528 94 06, Portugal 351 1 726 9011, Singapore 2265886, Spain 91 640 0085,  
Sweden 08 587 895 00, Switzerland 056 200 51 51, Taiwan 02 2528 7227, United Kingdom 01635 523545

For further support information, see the *Technical Support Resources* appendix. To comment on the documentation, send e-mail to [techpubs@ni.com](mailto:techpubs@ni.com).

Copyright © 2001 National Instruments Corporation. All rights reserved.

# Important Information

---

## Warranty

The NI 8171 series of embedded PXI computers are warranted against defects in materials and workmanship for a period of one year from the date of shipment, as evidenced by receipts or other documentation. National Instruments will, at its option, repair or replace equipment that proves to be defective during the warranty period. This warranty includes parts and labor.

The media on which you receive National Instruments software are warranted not to fail to execute programming instructions, due to defects in materials and workmanship, for a period of 90 days from date of shipment, as evidenced by receipts or other documentation. National Instruments will, at its option, repair or replace software media that do not execute programming instructions if National Instruments receives notice of such defects during the warranty period. National Instruments does not warrant that the operation of the software shall be uninterrupted or error free.

A Return Material Authorization (RMA) number must be obtained from the factory and clearly marked on the outside of the package before any equipment will be accepted for warranty work. National Instruments will pay the shipping costs of returning to the owner parts which are covered by warranty.

National Instruments believes that the information in this document is accurate. The document has been carefully reviewed for technical accuracy. In the event that technical or typographical errors exist, National Instruments reserves the right to make changes to subsequent editions of this document without prior notice to holders of this edition. The reader should consult National Instruments if errors are suspected. In no event shall National Instruments be liable for any damages arising out of or related to this document or the information contained in it.

EXCEPT AS SPECIFIED HEREIN, NATIONAL INSTRUMENTS MAKES NO WARRANTIES, EXPRESS OR IMPLIED, AND SPECIFICALLY DISCLAIMS ANY WARRANTY OF MERCHANTABILITY OR FITNESS FOR A PARTICULAR PURPOSE. CUSTOMER'S RIGHT TO RECOVER DAMAGES CAUSED BY FAULT OR NEGLIGENCE ON THE PART OF NATIONAL INSTRUMENTS SHALL BE LIMITED TO THE AMOUNT THEREOF PAID BY THE CUSTOMER. NATIONAL INSTRUMENTS WILL NOT BE LIABLE FOR DAMAGES RESULTING FROM LOSS OF DATA, PROFITS, USE OF PRODUCTS, OR INCIDENTAL OR CONSEQUENTIAL DAMAGES, EVEN IF ADVISED OF THE POSSIBILITY THEREOF. This limitation of the liability of National Instruments will apply regardless of the form of action, whether in contract or tort, including negligence. Any action against National Instruments must be brought within one year after the cause of action accrues. National Instruments shall not be liable for any delay in performance due to causes beyond its reasonable control. The warranty provided herein does not cover damages, defects, malfunctions, or service failures caused by owner's failure to follow the National Instruments installation, operation, or maintenance instructions; owner's modification of the product; owner's abuse, misuse, or negligent acts; and power failure or surges, fire, flood, accident, actions of third parties, or other events outside reasonable control.

## Copyright

Under the copyright laws, this publication may not be reproduced or transmitted in any form, electronic or mechanical, including photocopying, recording, storing in an information retrieval system, or translating, in whole or in part, without the prior written consent of National Instruments Corporation.

## Trademarks

CVI™, LabVIEW™, National Instruments™, NI™, NI-488.2™, NI-488.2M™, ni.com™, NI-DAQ™, and NI-VISA™ are trademarks of National Instruments Corporation.

Product and company names mentioned herein are trademarks or trade names of their respective companies.

## WARNING REGARDING USE OF NATIONAL INSTRUMENTS PRODUCTS

(1) NATIONAL INSTRUMENTS PRODUCTS ARE NOT DESIGNED WITH COMPONENTS AND TESTING FOR A LEVEL OF RELIABILITY SUITABLE FOR USE IN OR IN CONNECTION WITH SURGICAL IMPLANTS OR AS CRITICAL COMPONENTS IN ANY LIFE SUPPORT SYSTEMS WHOSE FAILURE TO PERFORM CAN REASONABLY BE EXPECTED TO CAUSE SIGNIFICANT INJURY TO A HUMAN.

(2) IN ANY APPLICATION, INCLUDING THE ABOVE, RELIABILITY OF OPERATION OF THE SOFTWARE PRODUCTS CAN BE IMPAIRED BY ADVERSE FACTORS, INCLUDING BUT NOT LIMITED TO FLUCTUATIONS IN ELECTRICAL POWER SUPPLY, COMPUTER HARDWARE MALFUNCTIONS, COMPUTER OPERATING SYSTEM SOFTWARE FITNESS, FITNESS OF COMPILERS AND DEVELOPMENT SOFTWARE USED TO DEVELOP AN APPLICATION, INSTALLATION ERRORS, SOFTWARE AND HARDWARE COMPATIBILITY PROBLEMS, MALFUNCTIONS OR FAILURES OF ELECTRONIC MONITORING OR CONTROL DEVICES, TRANSIENT FAILURES OF ELECTRONIC SYSTEMS (HARDWARE AND/OR SOFTWARE), UNANTICIPATED USES OR MISUSES, OR ERRORS ON THE PART OF THE USER OR APPLICATIONS DESIGNER (ADVERSE FACTORS SUCH AS THESE ARE HEREAFTER COLLECTIVELY TERMED "SYSTEM FAILURES"). ANY APPLICATION WHERE A SYSTEM FAILURE WOULD CREATE A RISK OF HARM TO PROPERTY OR PERSONS (INCLUDING THE RISK OF BODILY INJURY AND DEATH) SHOULD NOT BE RELIANT SOLELY UPON ONE FORM OF ELECTRONIC SYSTEM DUE TO THE RISK OF SYSTEM FAILURE. TO AVOID DAMAGE, INJURY, OR DEATH, THE USER OR APPLICATION DESIGNER MUST TAKE REASONABLY PRUDENT STEPS TO PROTECT AGAINST SYSTEM FAILURES, INCLUDING BUT NOT LIMITED TO BACK-UP OR SHUT DOWN MECHANISMS. BECAUSE EACH END-USER SYSTEM IS CUSTOMIZED AND DIFFERS FROM NATIONAL INSTRUMENTS' TESTING PLATFORMS AND BECAUSE A USER OR APPLICATION DESIGNER MAY USE NATIONAL INSTRUMENTS PRODUCTS IN COMBINATION WITH OTHER PRODUCTS IN A MANNER NOT EVALUATED OR CONTEMPLATED BY NATIONAL INSTRUMENTS, THE USER OR APPLICATION DESIGNER IS ULTIMATELY RESPONSIBLE FOR VERIFYING AND VALIDATING THE SUITABILITY OF NATIONAL INSTRUMENTS PRODUCTS WHENEVER NATIONAL INSTRUMENTS PRODUCTS ARE INCORPORATED IN A SYSTEM OR APPLICATION, INCLUDING, WITHOUT LIMITATION, THE APPROPRIATE DESIGN, PROCESS AND SAFETY LEVEL OF SUCH SYSTEM OR APPLICATION.

# Compliance

---

## FCC/Canada Radio Frequency Interference Compliance\*

### Determining FCC Class

The Federal Communications Commission (FCC) has rules to protect wireless communications from interference. The FCC places digital electronics into two classes. These classes are known as Class A (for use in industrial-commercial locations only) or Class B (for use in residential or commercial locations). Depending on where it is operated, this product could be subject to restrictions in the FCC rules. (In Canada, the Department of Communications (DOC), of Industry Canada, regulates wireless interference in much the same way.)

Digital electronics emit weak signals during normal operation that can affect radio, television, or other wireless products. By examining the product you purchased, you can determine the FCC Class and therefore which of the two FCC/DOC Warnings apply in the following sections. (Some products may not be labeled at all for FCC; if so, the reader should then assume these are Class A devices.)

FCC Class A products only display a simple warning statement of one paragraph in length regarding interference and undesired operation. Most of our products are FCC Class A. The FCC rules have restrictions regarding the locations where FCC Class A products can be operated.

FCC Class B products display either a FCC ID code, starting with the letters EXN, or the FCC Class B compliance mark that appears as shown here on the right.

Consult the FCC web site <http://www.fcc.gov> for more information.

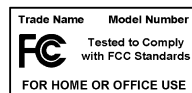

### FCC/DOC Warnings

This equipment generates and uses radio frequency energy and, if not installed and used in strict accordance with the instructions in this manual and the CE Mark Declaration of Conformity\*\*, may cause interference to radio and television reception. Classification requirements are the same for the Federal Communications Commission (FCC) and the Canadian Department of Communications (DOC).

Changes or modifications not expressly approved by National Instruments could void the user's authority to operate the equipment under the FCC Rules.

### Class A

#### Federal Communications Commission

This equipment has been tested and found to comply with the limits for a Class A digital device, pursuant to part 15 of the FCC Rules. These limits are designed to provide reasonable protection against harmful interference when the equipment is operated in a commercial environment. This equipment generates, uses, and can radiate radio frequency energy and, if not installed and used in accordance with the instruction manual, may cause harmful interference to radio communications. Operation of this equipment in a residential area is likely to cause harmful interference in which case the user will be required to correct the interference at his own expense.

#### Canadian Department of Communications

This Class A digital apparatus meets all requirements of the Canadian Interference-Causing Equipment Regulations.

Cet appareil numérique de la classe A respecte toutes les exigences du Règlement sur le matériel brouilleur du Canada.

### Class B

#### Federal Communications Commission

This equipment has been tested and found to comply with the limits for a Class B digital device, pursuant to part 15 of the FCC Rules. These limits are designed to provide reasonable protection against harmful interference in a residential installation. This equipment generates, uses and can radiate radio frequency energy and, if not installed and used in accordance with the instructions, may cause harmful interference to radio communications. However, there is no guarantee that interference will not occur in a particular installation. If this equipment does cause harmful interference to radio or television reception, which can be determined by turning the equipment off and on, the user is encouraged to try to correct the interference by one or more of the following measures:

- Reorient or relocate the receiving antenna.
- Increase the separation between the equipment and receiver.
- Connect the equipment into an outlet on a circuit different from that to which the receiver is connected.
- Consult the dealer or an experienced radio/TV technician for help.

## Canadian Department of Communications

This Class B digital apparatus meets all requirements of the Canadian Interference-Causing Equipment Regulations.

Cet appareil numérique de la classe B respecte toutes les exigences du Règlement sur le matériel brouilleur du Canada.

## Compliance to EU Directives

Readers in the European Union (EU) must refer to the Manufacturer's Declaration of Conformity (DoC) for information\*\* pertaining to the CE Mark compliance scheme. The Manufacturer includes a DoC for most every hardware product except for those bought for OEMs, if also available from an original manufacturer that also markets in the EU, or where compliance is not required as for electrically benign apparatus or cables.

To obtain the DoC for this product, click **Declaration of Conformity** at [ni.com/hardref.nsf/](http://ni.com/hardref.nsf/). This web site lists the DoCs by product family. Select the appropriate product family, followed by your product, and a link to the DoC appears in Adobe Acrobat format. Click the Acrobat icon to download or read the DoC.

\* Certain exemptions may apply in the USA, see FCC Rules §15.103 **Exempted devices**, and §15.105(c). Also available in sections of CFR 47.

\*\* The CE Mark Declaration of Conformity will contain important supplementary information and instructions for the user or installer.

# Contents

---

## About This Manual

How to Use the Documentation Set.....	xi
Conventions .....	xi
Related Documentation.....	xii

## Chapter 1

### Introduction

Benefits of PXI .....	1-1
NI 8171 Series .....	1-1
Description .....	1-1
Modules .....	1-2
Functional Overview .....	1-2
National Instruments Software .....	1-5

## Chapter 2

### Installation and Configuration

Installing the NI 8171 Series .....	2-1
How to Remove the Controller from the PXI Chassis .....	2-3
BIOS Setup .....	2-3
Entering BIOS Setup .....	2-3
Main Setup Menu .....	2-4
Advanced Setup Menu .....	2-5
PXI Setup Menu .....	2-7
Security Setup Menu .....	2-8
Boot Setup Menu .....	2-8
Exiting BIOS Setup .....	2-9
System CMOS .....	2-10
Using the Controllers with PXI-1020 and PXI-1025 Chassis .....	2-11
LCD Display.....	2-11
IDE CD-ROM Drive .....	2-11
Chassis Mouse and Keyboard .....	2-12
Drivers and Software .....	2-12
Files and Directories Installed on Your Hard Drive.....	2-12
PXI Features .....	2-13
PXI Trigger Connectivity .....	2-13

Upgrading RAM.....	2-13
Hard Drive Recovery.....	2-14
Recovery from a CD-ROM.....	2-14
Recovery from a Network.....	2-15
Installing an OS.....	2-15
Installing from a CD-ROM.....	2-15
Installing from a Network.....	2-16

## **Chapter 3**

### **I/O Information**

Front Panel Connectors.....	3-1
VGA.....	3-2
COM1 and COM2.....	3-3
Ethernet.....	3-4
Parallel Port.....	3-5
Universal Serial Bus.....	3-7
PS/2.....	3-8
Trigger.....	3-9
GPIO (IEEE 488.2).....	3-10
Front Panel Features.....	3-11
Data Storage.....	3-11
PXI-1020 and PXI-1025 Chassis Interface.....	3-12

## **Chapter 4**

### **Common Configuration Questions**

General Questions.....	4-1
Boot Options.....	4-1
Cables and Connections.....	4-2
Operating System and Software Driver Installation.....	4-3
Hard Drive Recovery.....	4-4
Chassis Configuration.....	4-5
Upgrade Information.....	4-6
Windows NT4 Issues.....	4-8
PXI Configuration.....	4-8

## **Chapter 5**

### **Troubleshooting**

**Appendix A  
Specifications**

**Appendix B  
Technical Support Resources**

**Glossary**

**Index**



# About This Manual

---

This manual contains detailed instructions for installing and configuring your National Instruments NI 8171 series embedded computer kit. The NI 8171 series includes the NI 8176, NI 8175, and NI 8174 embedded PXI computers.

## How to Use the Documentation Set



---

Begin by reading the *NI 8171 Series Installation Guide*, a brief quick-start guide that describes how to install and get started with your controller.

This manual, the *NI 8171 Series User Manual*, contains more details about changing the installation or configuration from the defaults and using the hardware.

## Conventions

---

	The following conventions appear in this manual:
	This icon denotes a caution, which advises you of precautions to take to avoid injury, data loss, or a system crash.
<b>bold</b>	Bold text denotes items that you must select or click on in the software, such as menu items and dialog box options. Bold text also denotes parameter names.
<i>italic</i>	Italic text denotes variables, emphasis, a cross reference, or an introduction to a key concept. This font also denotes text that is a placeholder for a word or value that you must supply.
monospace	Text in this font denotes text or characters that you should enter from the keyboard, sections of code, programming examples, and syntax examples. This font is also used for the proper names of disk drives, paths, directories, programs, subprograms, subroutines, device names, functions, operations, variables, filenames and extensions, and code excerpts.
NI 8171 series	The terms <i>NI 8171 series</i> and <i>NI 8171</i> refer to a series of 3U PXI controllers. Currently, this series consists of the NI 8174, NI 8175, and NI 8176.

## Related Documentation

---

The following documents contain information you may find helpful as you read this manual:

- *PICMG 2.0 R2.1 CompactPCI Specification*, PCI Industrial Computers Manufacturers Group
- IEEE Standard P1284.1-1997 (*C/MM*) *Standard for Information Technology for Transport Independent Printer/System Interface*
- *PCI Local Bus Specification*, Revision 2.2, PCI Special Interest Group
- *PXI Specification*, Revision 2.0, National Instruments Corporation
- *Serialized IRQ Support for PCI Systems Specification*, Revision 6.0, Compaq Computer et al.

---

# Introduction

## Benefits of PXI

---

The PXIbus specification defines a compact modular PC platform for industrial instrumentation. PXI leverages the PCI bus, which is the *de facto* standard for today's desktop computer software and hardware designs. As a result, PXI users receive all the benefits of PCI within an architecture that supports mechanical, electrical, and software features tailored to industrial instrumentation, data acquisition, and automation applications.

Well-suited for industrial applications, PXI leverages from the CompactPCI specification, which defines a rugged form factor for PCI that offers superior mechanical integrity and easy installation and removal of hardware components. PXI products offer higher and more carefully defined levels of environmental performance required by the vibration, shock, temperature, and humidity extremes of industrial environments. PXI adds mandatory environmental testing and active cooling to the CompactPCI mechanical specification to ease system integration and ensure multivendor interoperability.

Additionally, PXI meets the more specific needs of instrumentation users by adding an integrated trigger bus and reference clock for multiple-board synchronization, a star trigger bus for very precise timing, and local buses for side-band communication between adjacent peripherals.

## NI 8171 Series

---

### Description

The NI 8171 series PXI/CompactPCI embedded computer is a high-performance PXI/CompactPCI-compatible system controller. The NI 8171 series controllers integrate standard I/O features in a single unit by using state-of-the-art packaging. Combining a NI 8171 series embedded controller with a PXI-compatible chassis, such as the PXI-1000B, results in a fully PC-compatible computer in a compact, rugged package.

## Modules

The NI 8171 series includes three configurations: the NI 8176, NI 8175, and NI 8174.

All three modules have a standard I/O set, and some modules include additional I/O connections. The standard I/O on all modules includes video, RS-232 serial port, parallel port, two USB ports, 10/100 ENET, PS/2 mouse and keyboard port, Reset button, and PXI Trigger. The modules have the following configurations:

- The NI 8176 has a 1.26 GHz processor, all the standard I/O, a second serial port, a PCI-based GPIB controller, an integrated 1.44 MB floppy drive, a 10 GB (or larger) hard drive, and PXI-1020/PXI-1025 chassis support.
- The NI 8175 has an 866 MHz processor, all the standard I/O, a second serial port, an integrated 1.44 MB floppy drive, a 10 GB (or larger) hard drive, and PXI-1020/1025 chassis support.
- The NI 8174 has a 566 MHz processor, all the standard I/O, and a 10 GB (or larger) hard drive.

## Functional Overview

This section contains functional descriptions of each major logic block on the NI 8171 series embedded computers.

### NI 8171 Series Functional Description

The NI 8171 series is a modular PC in a PXI 3U-size form factor. Figure 1-1 is a functional block diagram of the NI 8171 series. Following the diagram is a description of each logic block shown.

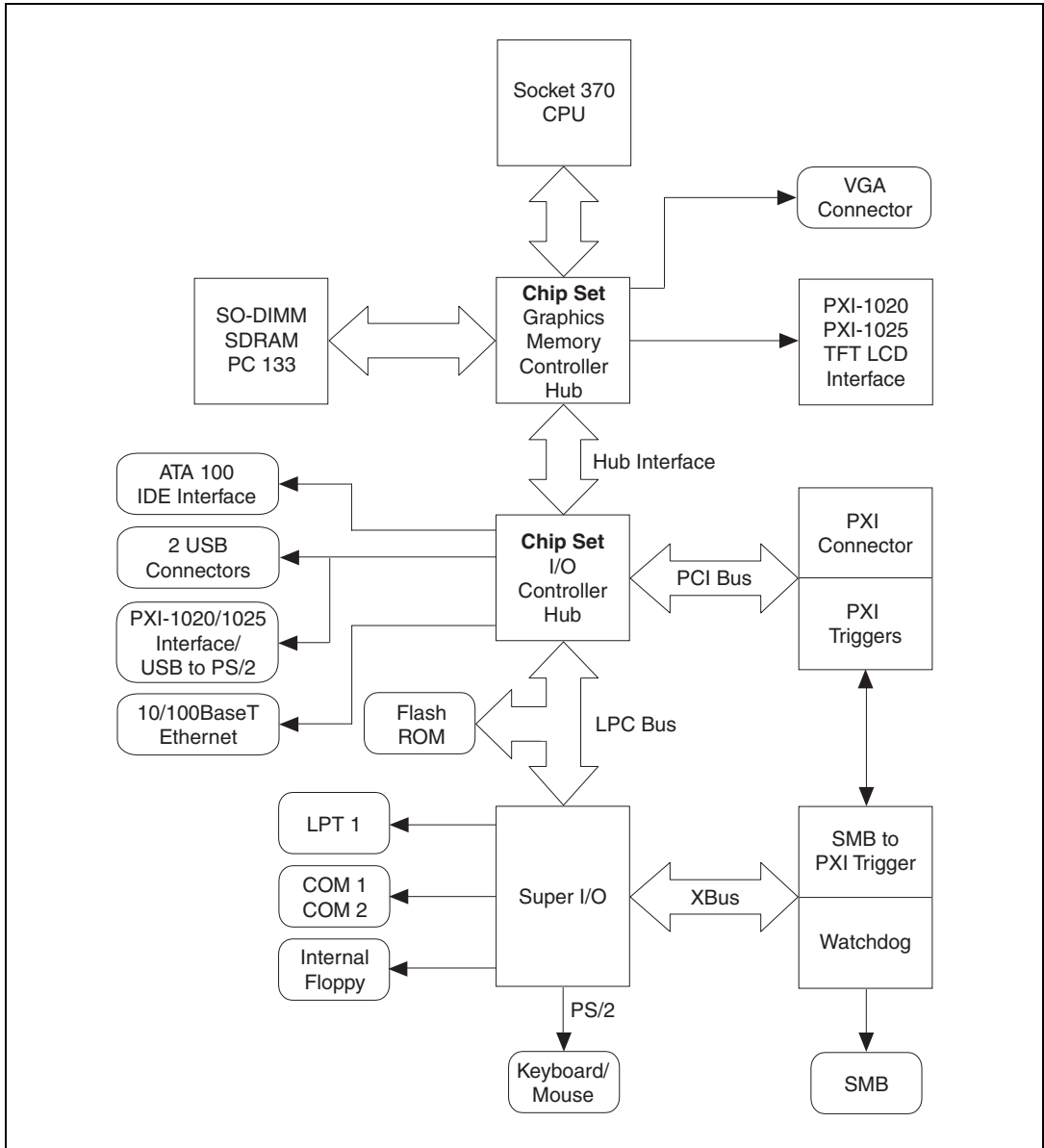

Figure 1-1. NI 8171 Series Block Diagram

The NI 8171 series consists of the following logic blocks on the CPU module and the I/O (daughter card) module. The CPU module has the following logic blocks:

- *Socket 370 CPU* is the socket definition for the Intel Pentium III processor families.
- The *SO-DIMM* block consists of a 64-bit SDRAM socket that can hold up to 256 MB.
- The *Chip Set GMCH* connects to the CPU, SDRAM, and video.
- The *SMB to PXI triggers* provide a routable connection of the PXI triggers to/from the SMB on the front panel.
- The *Watchdog Timer* block consists of a watchdog timer that can reset the controller or generate a trigger.
- The *Chip Set ICH2* connects to the PCI bus USB, IDE, LPC, and Ethernet ports.
- The *USB connector* connects the chip set to the Universal Serial Bus interface.
- The *PXI connector* connects the NI 8171 series to the PXI/CompactPCI backplane.
- The *Keyboard/Mouse* block contains the PS/2 keyboard and mouse interface.
- The *Super I/O* block represents the other peripherals supplied by the NI 8171 series. The NI 8171 series has up to two serial ports, an ECP/EPP parallel port, and a 1.44 MB, 3.5 in. floppy drive.
- The *IDE* block is dedicated PCI-IDE circuitry providing fast ATA-100 transfers to the internal hard drive. The IDE feature is built into the chip set.
- The *10/100 Enet* connects to either 10 Mbit or 100 Mbit Ethernet interfaces.
- Internal 1.44 MB floppy drive (NI 8176 and NI 8175 only)
- 2.5 in. hard drive—10 GB or larger
- TFT LCD interface for PXI-1020 and PXI-1025 chassis
- USB-to-PS/2 interface for PXI-1020 and PXI-1025 chassis

# National Instruments Software

---

National Instruments has developed several software kits you can use with the NI 8171 series. The software is already installed on your hard drive.

NI-DAQ has an extensive library of functions that you can call from your application programming environment. These functions include routines for analog input (A/D conversion), buffered data acquisition (high-speed A/D conversion), analog output (D/A conversion), waveform generation, digital I/O, counter/timer operations, SCXI, RTSI, self-calibration, messaging, and acquiring data to extended memory.

NI-VISA is the National Instruments implementation of the VISA specification. VISA is a uniform API for communicating and controlling Serial, GPIB, PXI, VXI, and various other types of instruments. This API aids in the creation of more portable applications and instrument drivers. For information on writing your own PXI instrument driver with NI-VISA, see the *NI-VISA Getting Started* manual and the `readme.txt` file in the NI-VISA directory.

You can also use the National Instruments LabVIEW and Measurement Studio application programs and instrument drivers to ease your programming task. These standardized programs match the modular virtual instrument capability of PXI and can reduce your PXI software development time. These programs feature extensive libraries of GPIB, Serial, and VXI instrument drivers written to take full advantage of direct PXI control. LabVIEW and Measurement Studio include all the tools needed for instrument control, data acquisition, analysis, and presentation.

LabVIEW is an easy-to-use, graphical programming environment you can use to acquire data from thousands of different instruments, including IEEE 488.2 devices, VXI devices, serial devices, PLCs, and plug-in data acquisition boards. After you have acquired raw data, you can convert it into meaningful results using the powerful data analysis routines in LabVIEW. LabVIEW also comes with hundreds of instrument drivers, which dramatically reduce software development time, because you do not have to spend time programming the low-level control of each instrument.

Measurement Studio bundles LabWindows/CVI for C programmers, ComponentWorks for Microsoft Visual Basic programmers, and ComponentWorks++ for Microsoft Visual C++ programmers. Measurement Studio is designed for building measurement and automation applications with the programming environment of your choice:

- LabWindows/CVI is an interactive ANSI C programming environment designed for building virtual instrument applications. LabWindows/CVI delivers a drag-and-drop editor for building user interfaces, a complete ANSI C environment for building your test program logic, and a collection of automated code generation tools, as well as utilities for building automated test systems, monitoring applications, or laboratory experiments.
- ComponentWorks for Visual Basic is a collection of ActiveX controls designed for building virtual instrumentation systems. Based on ActiveX technology, ComponentWorks controls are configured through simple property pages. You can use the ComponentWorks GPIB, Serial, and VISA I/O controls and property pages to set up communication with your instruments.
- ComponentWorks++ for Visual C++ takes advantage of integrated C++ libraries and ActiveX to help you build measurement and automation applications. With the ComponentWorks++ instrument classes, you can use the IEEE 488.2 library and VISA, an industry-standard I/O library, to communicate with GPIB, VXI, PXI, TCP/IP, or Serial devices using the same set of components.



---

# Installation and Configuration

This chapter contains information about installing and configuring your NI 8171 series controller.

## Installing the NI 8171 Series

---

This section contains general installation instructions for the NI 8171 series. Consult your PXI chassis user manual for specific instructions and warnings.

1. Plug in your chassis before installing the NI 8171 series. The power cord grounds the chassis and protects it from electrical damage while you install the module. (Make sure the power switch is turned off.)



**Caution** To protect both yourself and the chassis from electrical hazards, leave the chassis off until you finish installing the NI 8171 series module.

2. Remove any filler panels blocking access to the system controller slot (Slot 1) in the chassis.
3. Touch the metal part of the case to discharge any static electricity that might be on your clothes or body.
4. Make sure the injector/ejector handle is in its downward position. Align the NI 8171 series with the card guides on the top and bottom of the system controller slot.



**Caution** Do *not* raise the injector/ejector handle as you insert the NI 8171 series. The module will not insert properly unless the handle is in its downward position so that it does not interfere with the injector rail on the chassis.

5. Hold the handle as you slowly slide the module into the chassis until the handle catches on the injector/ejector rail.
6. Raise the injector/ejector handle until the module firmly seats into the backplane receptacle connectors. The front panel of the NI 8171 series should be even with the front panel of the chassis.
7. Tighten the four bracket-retaining screws on the top and bottom of the front panel to secure the NI 8171 series to the chassis.

8. Check the installation.
9. Connect the keyboard and mouse to the appropriate connectors. If you are using a PS/2 keyboard and a PS/2 mouse, use the Y-splitter adapter (see Figure 4-1, *Y-Splitter Cable*) included with your controller to connect both to the PS/2 connector.
10. Connect the VGA monitor video cable to the VGA connector.
11. Connect devices to ports as required by your system configuration.
12. Power on the chassis.
13. Verify that the controller boots. If the controller does not boot, see the *What if the NI 8171 series does not boot?* section in Chapter 5, *Troubleshooting*.

Figure 2-1 shows an NI 8176 installed in the system controller slot of a National Instruments PXI-1000 chassis. You can place PXI devices in any other slot.

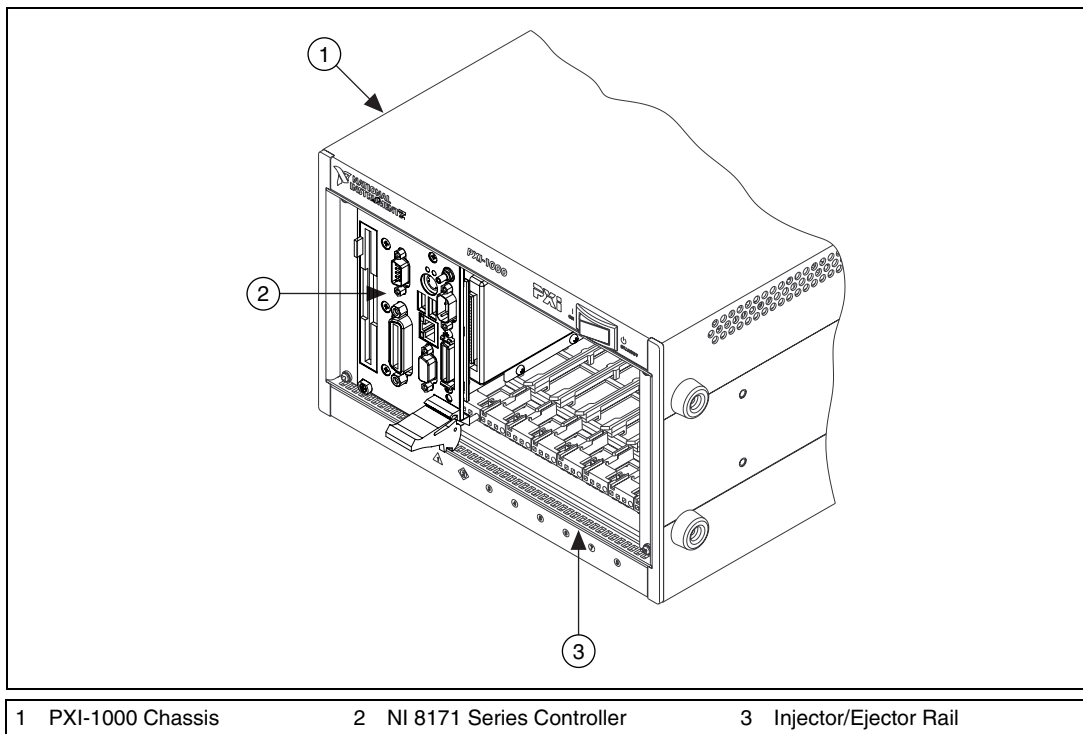

**Figure 2-1.** NI 8171 Series Controller Installed in a PXI Chassis

## How to Remove the Controller from the PXI Chassis

The NI 8171 series controllers are designed for easy handling. To remove the unit from the PXI chassis:

1. Turn off power.
2. Remove the bracket-retaining screws in the front panel.
3. Press the injector/ejector handle down.
4. Slide the unit out of the chassis.

## BIOS Setup

---

You can change the NI 8171 series configuration settings in the BIOS setup. The BIOS is the low-level interface between the hardware and PC software that configures and tests your hardware when you boot the system. The BIOS setup program includes menus for configuring settings and enabling NI 8171 series controller features.

Most users do not need to use the BIOS setup program, as the NI 8171 series controller ships with default settings that work well for most configurations.



**Caution** Changing BIOS settings may lead to incorrect controller behavior and possibly an unbootable controller. If this happens, follow the instructions for restoring default settings in the *System CMOS* section. In general, do *not* change a setting unless you are absolutely certain what it does.

## Entering BIOS Setup

To start the BIOS setup utility:

1. Turn on or reboot your NI 8171 series controller.
2. When the message **Press <DEL> to enter SETUP** appears, press <Delete> or <Del> on the numeric keypad. The message **Entering Setup...** appears, and the setup program is loaded after a short delay.
3. When you first enter the BIOS setup program, it displays the **Main** menu.

Use the following keys to navigate through the BIOS setup:

- **Left Arrow, Right Arrow**—Use these keys to move between the different setup menus. If you are in a submenu, these keys have no effect, and you need to press <Esc> to leave the submenu first. (To use the arrows on the numeric keypad, you must turn off Num Lock.)

- **Up Arrow, Down Arrow**—Use these keys to move between the options within a setup menu. (To use the arrows on the numeric keypad, you must turn off Num Lock.)
- **<Enter>**—Use this key to either enter a submenu or display all available settings for a highlighted configuration option.
- **<Esc>**—Use this key to return the parent menu of a submenu. At the top-level menus, this key serves as a shortcut to the **Exit** menu.
- **<+> and <->**—Use these keys to cycle between all available settings for a selected configuration option.

## Main Setup Menu

The most commonly accessed and modified BIOS settings are in the **Main** setup menu. The **Main** setup menu includes the following settings:

- **System Time & Date**—This setting controls the time of day, which is stored in a battery-backed real-time clock. Most operating systems also include a way to change this setting. Use <+> and <-> in conjunction with <Enter> to change these values.
- **DMI Event Logging**—This setting brings up the **DMI Event Logging** submenu (see the [DMI Event Logging Submenu](#) section).
- **Keyboard Required to Boot**—When **Yes**, a missing or malfunctioning keyboard causes the BIOS to halt with an error. When **No**, the BIOS allows booting without a keyboard, and you can attach a keyboard at any time during the powered up state. To use this controller in a “headless” mode, you must set this option to **No**. The default value is **Yes**.
- **Num Lock**—This setting indicates whether you turn on Num Lock at boot time. The default value is **On**.
- **Primary/Secondary Master/Slave**—These items display the IDE/ATA devices detected in the system. Normally, you do not need to modify these items. However, if an IDE/ATA device is not autodetected properly, you can specify it manually by pressing <Enter> on an item.
- **System Information**—This setting displays a screen containing important system information about the NI 8171 series controller.

## DMI Event Logging Submenu

Major errors that occur during the BIOS booting process are stored in battery-backed memory on the controller, and remain there until you view and clear them using this submenu. This logging capability allows a system administrator to detect the historical occurrence of faults on a controller. This submenu includes the following items:

- **View DMI Event Log**—This setting displays a window containing all logged system errors and the time at which they occurred.
- **Mark Events as Read**—This setting prevents any current logged entries from being displayed again. However, all entries remain in battery-backed memory, and you can retrieve them using other DMI software that is beyond the scope of this document.
- **Clear All Events**—When set to Yes, this setting clears all entries from the DMI event log on reboot.
- **Event Logging**—This setting controls whether events are logged. Disabling logging has no impact on system performance. The default is **Enabled**.

## Advanced Setup Menu

This menu contains BIOS settings that normally do not require modification. If you have specific problems such as unbootable disks or resource conflicts, you may need to examine these settings.



**Caution** Changing settings in this menu may result in an unstable or unbootable controller. If this happens, follow the procedures outlined in the [System CMOS](#) section to restore BIOS settings to their factory defaults.

The **Advanced** setup menu includes the following settings:

- **Reset Configuration Data**—A portion of the EEPROM on the controller is designated as the Extended System Configuration Data region (ESCD). The BIOS and Plug-and-Play operating systems use this table to store the *Last Known Good* configuration of system peripherals. If you experience resource conflicts or peripheral malfunction, set this setting to **Yes** to force the BIOS to recreate the ESCD on the next reboot. This is rarely necessary.
- **Integrated Peripherals**—Use this setting to bring up the **Integrated Peripherals** submenu (see the [Integrated Peripherals Submenu](#) section).
- **Local Bus IDE Adapter**—The NI 8171 series controller has two integrated IDE/ATA channels (Primary and Secondary), each capable

of supporting two ATA devices (Master and Slave). Use this setting to disable one or more of these integrated channels. You should modify this setting only if specified in other sections of this manual. The default is **Both**.

- **Write Protect Boot Sector**—When set to **Yes**, this setting prevents modification of a hard disk boot sector via INT 13h services, which may help prevent certain computer viruses from infecting the controller. This setting does not prevent boot sector modification by 32-bit operating system drivers that access the hard disk directly. The default is **No**.
- **Quick Boot Mode**—When you enable this option, certain lengthy BIOS tests that rarely fail are skipped to shorten controller boot time. The default is **Enabled**.
- **Summary Screen**—This setting controls the display of the summary screen shown after BIOS completes its initialization, but before booting takes place. You can disable this screen in the interest of shortening controller boot time. The default is **Disabled**.

## Integrated Peripherals Submenu

Use this submenu to apply nondefault configurations to the front panel peripherals of an NI 8171 series controller. Normally, you do not need to modify these settings, as the factory default settings provide the most compatible and optimal configuration possible.

- **Serial Port A & B**—This setting enables or disables COM1 and COM2, respectively. You can also change this setting to **Enabled** and modify the base address and Interrupt Request Level (IRQ) of a port. The default is **Auto**, which places COM1 at 0x3F8 IRQ 4 and COM2 at 0x2F8 IRQ 3.
- **Parallel Port**—Use this setting to enable or disable LPT1. You can also change this setting to **Enabled** and modify the base address, IRQ level, and ISA Direct Memory Access (DMA) channel of the port. The default is **Auto**, which places LPT1 at 0x378, IRQ 7, using ISA DMA Channel 3 if necessary.
- **Parallel Port Mode**—The PC industry has created several different modes of operation for this port over the years. Usually, the default setting works for all applications. However, if a parallel port device specifically requires a nondefault setting, you can change it here. The default is **Bidirectional**, for full IEEE 1284 capabilities.
- **Floppy Drive**—You can route the internal signals used for the 3.5 in. floppy drive operation through the pins on the parallel port connector. Use this setting to operate the NI 8171 series controller with a

specialized external floppy drive. Normally, using a Universal Serial Bus (USB) floppy drive is preferable to this option, which requires a specially designed drive and cable. (See the [Parallel Port](#) section in Chapter 3, [I/O Information](#), for pinout information.) Setting this option to **Parallel Port** disables normal LPT1 functionality. The Default is **Enabled**, which routes the signals to the standard internal floppy drive.

- **Legacy USB Support**—Use this setting to use a USB keyboard and mouse as if they were standard PS/2-style peripherals. You *must* enable this setting to use these devices in the BIOS Setup program, and when using operating systems with no USB support. Certain real-time applications may require you to disable this setting to reduce loop time jitter. The default is **Enabled**.

## PXI Setup Menu

Use this menu to control and route certain signals on the PXI backplane, as well as enable the LCD display for a PXI-1020 or PXI-1025 chassis.

Normally, you do not need to modify these settings. However, other sections of this manual may indicate that modifications are necessary and may lead to unpredictable behavior.

- **INTP Routing**—You can route INTP to ISA IRQ 14, for use by a PXI device functioning as a Primary IDE Controller. The default setting is **Not Routed**.
- **INTS Routing**—You can route INTS to ISA IRQ 15, for use by a PXI device functioning as a Secondary IDE Controller. You can also route it to the controller's 21-frame serialized IRQ input, for use by certain PXI carrier cards. The default setting is **Not Routed**.
- **LCD Display**—This setting allows the integrated LCD display of a PXI-1020 or PXI-1025 chassis to function as the primary display device for the NI 8171 series controller. See the [Using the Controllers with PXI-1020 and PXI-1025 Chassis](#) section for more information. The default is **Disabled**. This option is present only if the chassis has an integrated LCD.



**Note** If INTS or INTP is routed to an ISA IRQ, you must disable one or both channels of the integrated IDE/ATA controller for correct operation of this routing.

## Security Setup Menu

Use this menu to apply system-level passwords to the NI 8171 series controller. With these passwords, you can restrict access to the BIOS setup program, floppy drives, and operating systems installed on bootable devices. If you forget any password, you can restore the CMOS contents to the factory default as described in the *System CMOS* section of this manual.



**Note** In most chassis configurations, an unauthorized user has easy access to the jumper that resets the CMOS contents to the factory default. For a secure setup of this controller, National Instruments recommends further provisions that are beyond the scope of this document.

The Security setup menu includes the following settings:

- **Set Supervisor Password**—This setting sets the password that governs supervisor-level access to the BIOS setup screen and booting. The default is **no password**.
- **Set User Password**—This setting sets the password that governs user-level access to the BIOS setup screen and booting. If you enter BIOS setup using the user password, the only BIOS setting you can modify is the user password. The default is **no password**.
- **Password on Boot**—This setting controls whether the controller requires a supervisor or user password to boot an operating system. If you enter the supervisor password on boot, you have supervisor-level diskette access. If you enter the user password on boot, you have user-level diskette access.
- **Diskette Access**—This setting controls which level of access is required to access the floppy drive via INT 13h services. This setting has no effect on 32-bit operating systems drivers that access the floppy disk directly. The default is **Supervisor**.



**Note** To disable a current password, leave the new password field blank by simply pressing <Enter> on the field.

## Boot Setup Menu

This screen displays the boot order of devices associated with the controller. The BIOS proceeds down this list in search of a bootable device. If the BIOS fails to find any bootable device, the message **Operating System Not Found** is displayed, and the system halts.

- **Removable Devices**—The boot list includes all classes of floppy and ZIP drives, both internal and USB-based devices.



- **Hard Drive**—The boot list includes all IDE/ATA hard disks detected on the system. Press <Enter> on this entry to expand it to select the boot priority of individual IDE/ATA hard drives.
- **CD-ROM Drive**—The boot list includes all classes of CD-ROM drive, including USB drives and IDE/ATA drives integrated into a PXI-1020 or PXI-1025 chassis.
- **Network Boot**—This option is for National Instruments controllers with PXE ROM. The NI-8171 ENET controller will support this option in the future.



**Note** If an SCSI host adapter exists in the system, this menu has an additional entry for SCSI devices.

## Exiting BIOS Setup

The **Exit** setup menu includes all available options for exiting, saving, and loading the BIOS default configuration. As an alternative to this screen, use <F9> to load BIOS default settings and <F10> to save changes and exit setup.

The **Exit** setup menu includes the following settings:

- **Exit Saving Changes**—Any changes made to BIOS settings are stored in the battery-backed System CMOS. The setup program then exits and reboots the controller.
- **Exit Discarding Changes**—Any changes made to BIOS settings during this session of the BIOS setup program are discarded. The setup program then exits and boots the controller without rebooting first.
- **Load Setup Defaults**—This setting restores all BIOS settings to the factory default. This is useful if the controller exhibits unpredictable behavior due to an incorrect or inappropriate BIOS setting. Note that any nondefault settings such as boot order, passwords, and keyboardless operation are restored to their factory defaults. This may produce undesirable behavior, and in heavily customized cases, may cause the controller to malfunction or fail to boot.
- **Discard Changes**—Any changes made to BIOS settings during this session of the BIOS setup program are discarded. Unlike **Exit Discarding Changes**, however, the BIOS setup continues to be active.
- **Save Changes**—Changes made to BIOS settings during this session are committed to battery-backed System CMOS. The setup program remains active, allowing further changes.

## System CMOS

The NI 8171 series contains a backed-up memory used to store BIOS configuration information.

To clear the CMOS contents:

1. Turn off power.
2. Remove the controller from the chassis.
3. Move the jumper on J1 from pins 1-2 to pins 2-3 as shown in Figure 2-2.
4. Wait 1 second. Move the jumper back to pins 1-2.
5. Reinstall the controller in the chassis.



**Caution** Do *not* leave the jumper on pins 2-3. Doing so decreases battery life.

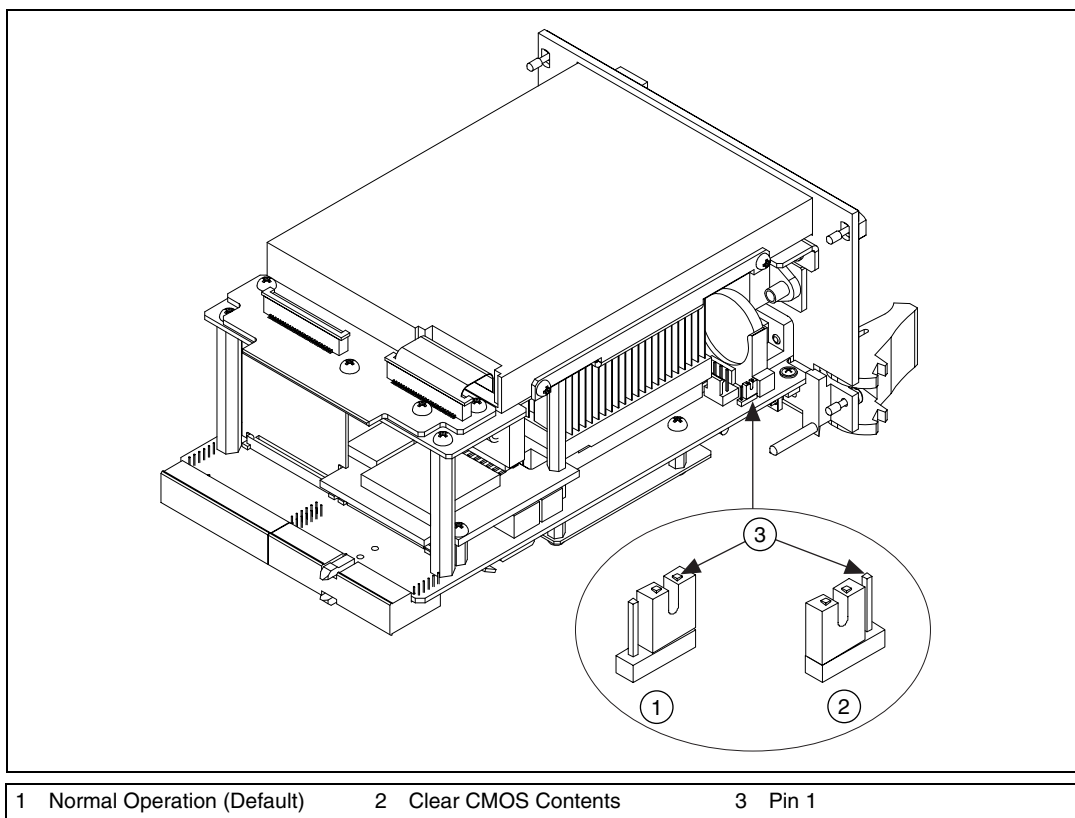

**Figure 2-2.** Clearing the CMOS Contents

# Using the Controllers with PXI-1020 and PXI-1025 Chassis

---

The NI 8176 and NI 8175 controllers interface directly to the National Instruments PXI-1020 and PXI-1025 chassis. The interface contains signals to interface to the chassis LCD display, IDE CDROM drive, and PS2 mouse and keyboard.

## LCD Display

To enable/disable the LCD display for a PXI-1020 or PXI-1025 chassis:

1. Install the controller in a PXI-1020 or PXI-1025 chassis.
2. Connect a CRT monitor to the VGA connector on the NI 8171 series controller.
3. Power on the chassis and enter the BIOS setup program during the boot. (When the message **Press <DEL> to enter SETUP** appears, press <Delete> or <Del> on the numeric keypad. The message **Entering Setup...** appears, and the setup program is loaded after a short delay.)
4. In the **PXI Setup** menu, set the LCD chassis setting to the correct value:
  - PXI-1020—Enables the LCD display and sets the resolution to 640 × 480.
  - PXI-1025—Enables the LCD display for the PXI-1025 chassis and sets the resolution to 800 × 600.
  - Disabled—Disables the LCD display even if the controller is installed in a PXI-1020 or PXI-1025 chassis.



**Note** If an LCD display does not exist or is malfunctioning, the BIOS Setup option is not visible.

## IDE CD-ROM Drive

The PXI-1020 and PXI-1025 chassis have integrated CD-ROM drives. The BIOS automatically detects the CD-ROM and enables the IDE interface. The OS loads drivers to access the CD-ROM. Refer to the [Boot Setup Menu](#) section for information on booting from the CD-ROM drive.

## Chassis Mouse and Keyboard

The PXI-1020 has an integrated PS/2 mouse. The PXI-1025 has an integrated PS/2 keyboard and mouse. To simplify configuration for these chassis, the NI 8171 series includes an internal USB-to-PS/2 adapter. When the NI 8171 series is installed in a PXI-1020 or PXI-1025 chassis, the USB-to-PS/2 adapter is enabled automatically. With this adapter, you can use both the chassis' integrated keyboard/mouse and the PS/2 keyboard and mouse connected to the NI 8171 series front panel. To enable keyboard/mouse access in DOS or Windows NT environments, you must enable the legacy USB. See the [Advanced Setup Menu](#) section for more information.

## Drivers and Software

---

### Files and Directories Installed on Your Hard Drive

Your hard drive includes a directory called `images` in its root that contains software and soft copies of manuals for the peripherals. The directory structure under the `images` directory is logically organized into several levels.

In the `images` directory itself, you will find a `manuals` directory, an `os` directory, and directories for each computer peripheral.

The `manuals` directory contains quick reference guides, technical reference manuals, and National Instruments software manuals, all in Adobe Acrobat format. To access any manual, change your directory to `c:\images\pxi8171>manuals` and list the contents of that directory. You will see several files, one corresponding to each peripheral.

The `os` directory contains a subdirectory corresponding to the operating system installed on your computer.

The rest of the directories correspond to each peripheral in your system. Within each of these directories are the drivers for the peripherals. These files and directories are copied exactly from the manufacturer distribution disks, so the naming conventions vary from peripheral to peripheral.

Because the naming conventions may not be completely straightforward, National Instruments provides a text file named `drivers.txt` in the `c:\images\pxi8171` directory. The `drivers.txt` file explains how to install support for each peripheral. You may want to print this file for reference when you install your peripheral device drivers.

# PXI Features

---

## PXI Trigger Connectivity

The SMB connector on the NI 8171 series front panel can connect to or from any PXI backplane trigger line through software. A trigger allocation process is needed to prevent two resources from connecting to the same trigger line, resulting in the trigger being double-driven and possibly damaging the hardware. At the time of this manual's publication, this software is not yet available; however, an interim trigger routing software utility is available from National Instruments. Contact National Instruments for more information.

## Upgrading RAM

---

You can change the amount of installed RAM on the NI 8171 series by upgrading the SO-DIMM.

To upgrade the RAM, remove the NI 8171 series from the PXI chassis. Remove the old SO-DIMM module and install the new SO-DIMM in the socket as shown in Figure 2-3.

National Instruments offers the following types of SO-DIMMs for use with the NI 8171 series controller.

- 128 MB, 16MB × 64, 7.5 ns, 1.05 in. max
- 256 MB, 32MB × 64, 7.5ns, 1.05 in. max



**Note** National Instruments has tested and verified that the SO-DIMMs we sell work with the NI 8171 series. We recommend you purchase your SO-DIMM modules from National Instruments. Other off-the-shelf SO-DIMM modules are not guaranteed to work properly.

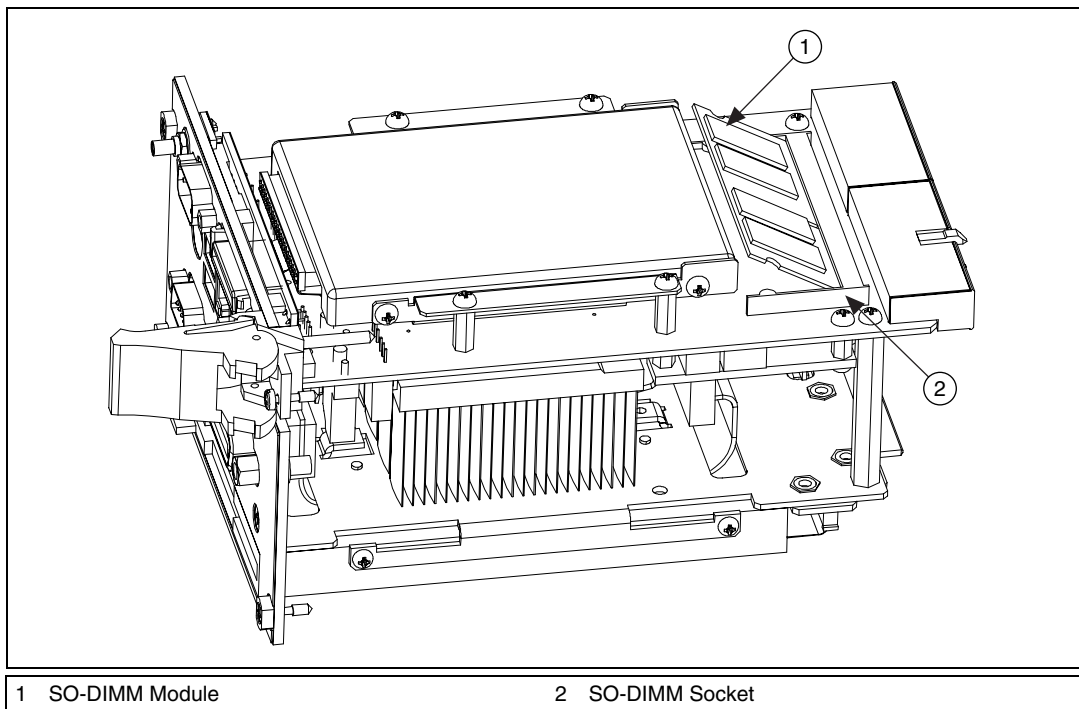

**Figure 2-3.** Installing a SO-DIMM in an NI 8171 Series Controller

## Hard Drive Recovery

The NI 8171 series controllers include a recovery CD. There are two methods for recovering the hard disk to its original state.

### Recovery from a CD-ROM

These steps apply to a USB CD-ROM, IDE CD-ROM (when using a PXI-1020 or PXI-1025 chassis), or SCSI CD-ROM drive (when a SCSI adapter is installed).

To recover the hard disk from a CD-ROM:

1. Load the recovery CD into the CD-ROM drive.
2. Press <Esc> during the BIOS POST. After POST, a boot menu is displayed. Select the CD-ROM drive.

3. The BIOS boots from CD-ROM drive. Follow the prompts to recover the hard drive.



**Note** Not all CD-ROMs are bootable with the NI 8171 series controllers. For a complete list of USB CD-ROM drives that National Instruments has verified as bootable, see [ni.com/support/pxisupp.htm](http://ni.com/support/pxisupp.htm).

## Recovery from a Network

To recover the hard disk from a network:

1. Create a DOS boot disk with network support. (The DOS network drivers and a network boot disk example are on the recovery CD.)
2. Use another PC on the network with a CD-ROM drive. Share the drive and load the recovery CD.
3. Boot the NI 8171 series using the network boot disk. Run the net utility from the a drive.
4. Map the shared CD-ROM drive to `K:`.
5. Run `K:\recover.bat`. Follow the prompts to recover the hard drive.

## Installing an OS

---

NI 8171 series controllers include a preinstalled OS. In some cases, you may want to reinstall the OS or install a different OS. When doing so, considering the following guidelines.

### Installing from a CD-ROM

Although the NI 8171 series can boot from a USB CD-ROM, you cannot install most operating systems from a USB CD-ROM drive. For example, Windows 2000 aborts during the install process because it does not have drivers for the CD-ROM device.

With DOS drivers, you can install Windows 9x operating systems. However, only a few USB CD-ROM drives have DOS drivers.

National Instruments does not recommend using a USB CD-ROM drive for CD-ROM OS installations. However, you can use a PXI-1020 or PXI-1025 chassis with an integrated IDE CD-ROM drive, or an external SCSI CD-ROM with a PXI-SCSI adapter.

## Installing from a Network

To install an OS from a network:

1. Create a DOS boot disk with network support. (The DOS network drivers and a network boot disk example are on the recovery CD.)
2. Use another PC on the network with a CD-ROM drive. Share the drive and load the OS installation CD.
3. Boot the NI 8171 series using the network boot disk.
4. Run the net utility from the a drive. Map the shared CD-ROM drive.
5. Run the OS setup program from the mapped drive or copy the CD-ROM image to the hard drive and run the OS setup program.



# I/O Information

## Front Panel Connectors

Table 3-1 lists various peripherals and their corresponding NI 8171 series external connectors, bus interfaces, and functions.

**Table 3-1.** NI 8171 Series Peripherals Overview

Peripheral	External Connector	Function	NI 8171 Series Models
Video	15-pin DSUB (standard VGA)	Integrated with Dynamic Video Memory	All
Serial	COM1 RS-232 Serial Port (9-pin DSUB)	16550 serial port	All
Serial	COM2 RS-232 Serial Port (9-pin DSUB)	16550 serial port	NI 8176 and NI 8175
10/100 Ethernet	Ethernet	Ethernet network connection	All
Parallel	Parallel Port (IEEE 1284)	Extended capabilities	All
USB	4-pin Series A receptacle	Universal Serial Bus (two ports on all models)	All
Keyboard/mouse	PS/2	PS/2-style keyboard and mouse (mouse requires PS/2 Y splitter)	All
PXI trigger	Trigger	Routing PXI triggers to or from the backplane trigger bus	All
GPIB device	GPIB (IEEE 488.2)	General-Purpose Interface Bus	NI 8176



**Note** In this chapter, the NI 8176 is shown in all illustrations. The connectors are in similar locations on all NI 8171 series modules.

## VGA

Figure 3-1 shows the location and pinouts for the VGA connector on the NI 8171 series. Table 3-2 lists and describes the VGA connector signals.

AMP manufactures a mating connector with part numbers 748364-1 (housing) and 748333-2 (pin contact).

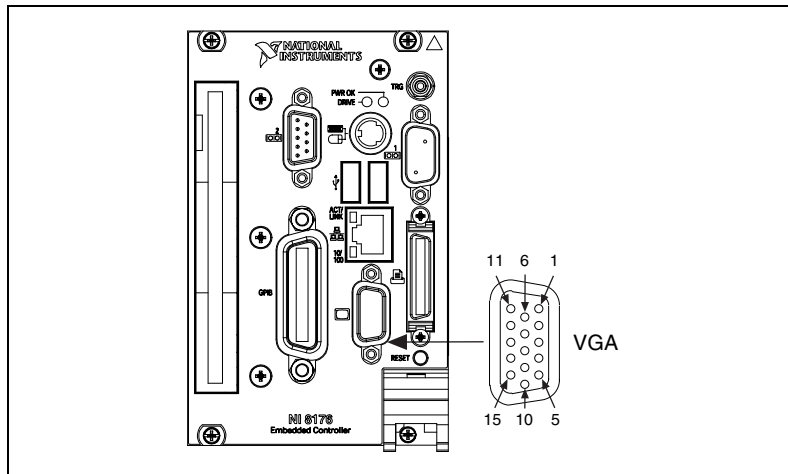

**Figure 3-1.** VGA Connector Location and Pinout

**Table 3-2.** VGA Connector Signals

Pin	Signal Name	Signal Description
1	R	Red
2	G	Green
3	B	Blue
4	NC	Not Connected
5	GND	Ground
6	GND	Ground
7	GND	Ground
8	GND	Ground
9	+5V	5 V
10	GND	Ground

**Table 3-2.** VGA Connector Signals (Continued)

Pin	Signal Name	Signal Description
11	NC	Not Connected
12	SD	Serial Data
13	HSync	Horizontal Sync
14	VSynC	Vertical Sync
15	SC	Serial Clock

## COM1 and COM2

Figure 3-2 shows the location and pinouts for the COM1 and COM2 connectors on the NI 8171 series. Table 3-3 lists and describes the COM1 and COM2 connector signal.

AMP manufactures a serial port mating connector, part number 745491-5.

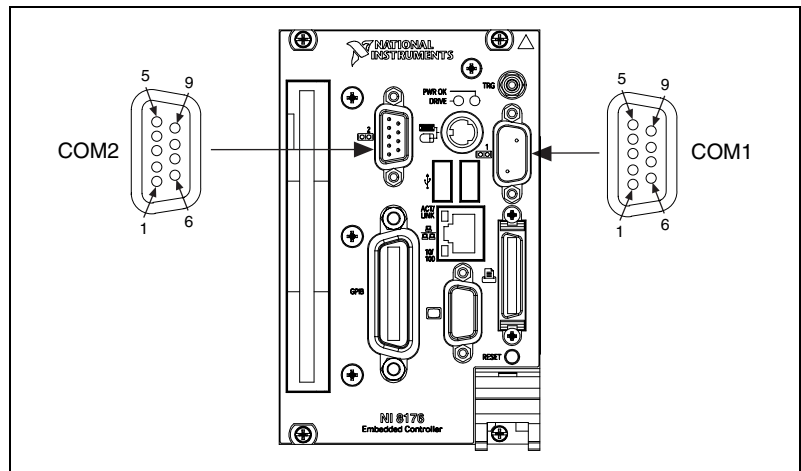
**Figure 3-2.** COM1 and COM2 Connector Location and Pinout**Table 3-3.** COM1 and COM2 Connector Signals

Pin	Signal Name	Signal Description
1	DCD*	Data Carrier Detect
2	RXD*	Receive Data
3	TXD*	Transmit Data

**Table 3-3.** COM1 and COM2 Connector Signals (Continued)

Pin	Signal Name	Signal Description
4	DTR*	Data Terminal Ready
5	GND	Ground
6	DSR*	Data Set Ready
7	RTS*	Ready to Send
8	CTS*	Clear to Send
9	RI*	Ring Indicator

## Ethernet

Figure 3-3 shows the location and pinouts for the Ethernet connector on the NI 8171 series. Table 3-4 lists and describes the Ethernet connector signals.

AMP manufactures a mating connector, part number 554739-1.

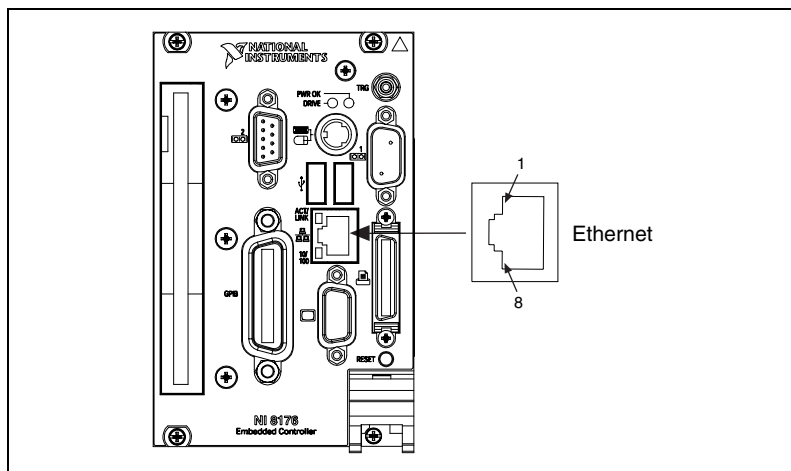

**Figure 3-3.** Ethernet Connector Location and Pinout

**Table 3-4.** Ethernet Connector Signals

Pin	Signal Description
1	Differential Transmit
2	Differential Transmit
3	Differential Receive
4	NC
5	NC
6	Differential Receive
7	NC
8	NC

## Parallel Port

Figure 3-4 shows the location and pinouts for the IEEE 1284 (parallel) connector on the NI 8171 series. Table 3-5 lists and describes the IEEE 1284 connector signals.

AMP manufactures a parallel port compatible connector, part number 747052-2.

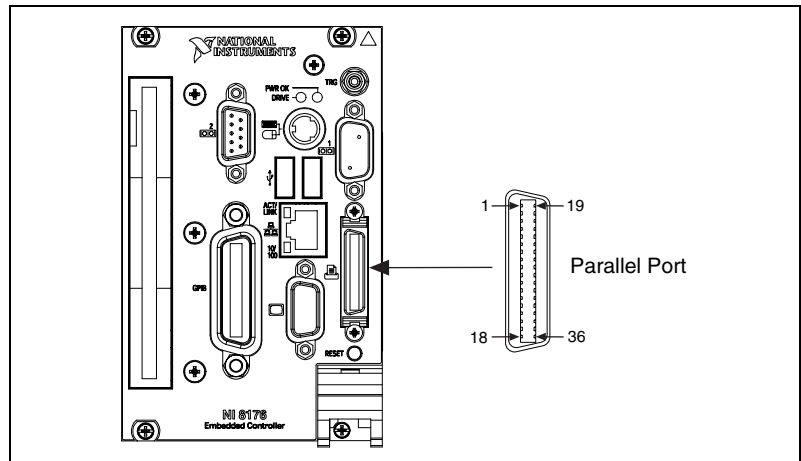
**Figure 3-4.** Parallel Port Connector Location and Pinout

**Table 3-5.** Parallel Port Connector Signals

Pin	Default Configuration (LPT)		Floppy Configuration (See <i>BIOS Setup</i> in Chapter 2, <i>Installation and Configuration</i> )	
	Signal Name	Signal Description	Signal Name	Signal Description
1	BUSY*	Device Busy	MTR1*	Motor on Disk 1
2	SLCTIN*	Select Input	Step*	Step Pulse
3	ACK*	Acknowledge	DS1*	Drive Select 1
4	FAULT*	Fault	WDATA*	Write Disk Data
5	ERROR	Error	HDSEL*	Head Select
6	PD0	Data Bit 0	Index*	Index Pulse Input
7	PD1	Data Bit 1	TRK0*	Track 0
8	PD 2	Data Bit 2	WRTPRT*	Write Protected
9	PD3	Data Bit 3	RDATA*	Read Disk Data
10	PD4	Data Bit 4	DSKCHG*	Disk Change
11	PD5	Data Bit 5	Not Used	—
12	PD6	Data Bit 6	MTR0*	Motor on Disk 0
13	PD7	Data Bit 7	Not Used	—
14	INIT*	Initialize Printer	DIR*	Step Direction
15	STROBE*	Strobe	DS0*	Drive Select 0
16	SLCT	Select	WGATE*	Write Gate
17	AUTOFD	Auto Line Feed	DRV DEN0*	Density Select
18	+5V	+5 V	+5V	+5 V
19-35	GND	Ground	GND	Ground
36	NC	Not Connected	NC	Not Connected

## Universal Serial Bus

Figure 3-5 shows the location and pinouts for the Universal Serial Bus (USB) connector on the NI 8171 series. Table 3-6 lists and describes the USB connector signals.

AMP manufactures a USB mating connector, part number 787633.

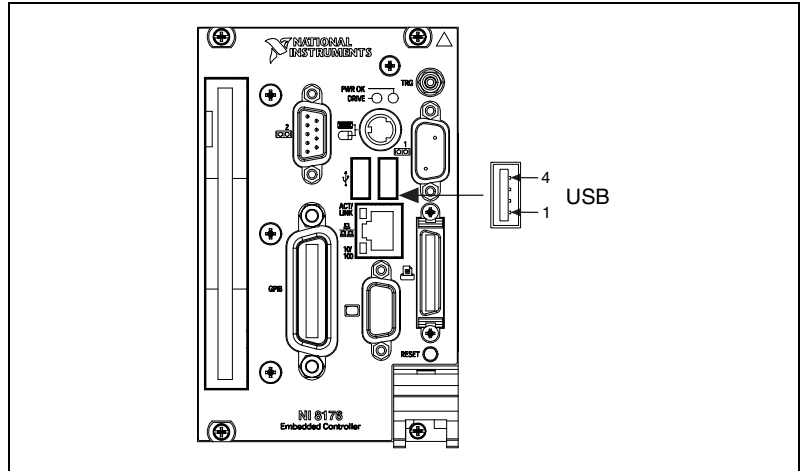

**Figure 3-5.** USB Connector Location and Pinout

**Table 3-6.** USB Connector Signals

Pin	Signal Name	Signal Description
1	VCC	Cable Power (+5 V)
2	-Data	USB Data-
3	+Data	USB Data+
4	GND	Ground

## PS/2

Figure 3-6 shows the location and pinouts for the PS/2 connector on the NI 8171 series. Table 3-7 lists and describes the PS/2 connector signals.

To connect both a PS/2 keyboard and PS/2 mouse to the NI 8171 series, use the Y-splitter adapter cable (see Figure 4-1 in Chapter 4, [Common Configuration Questions](#)) included with your controller.

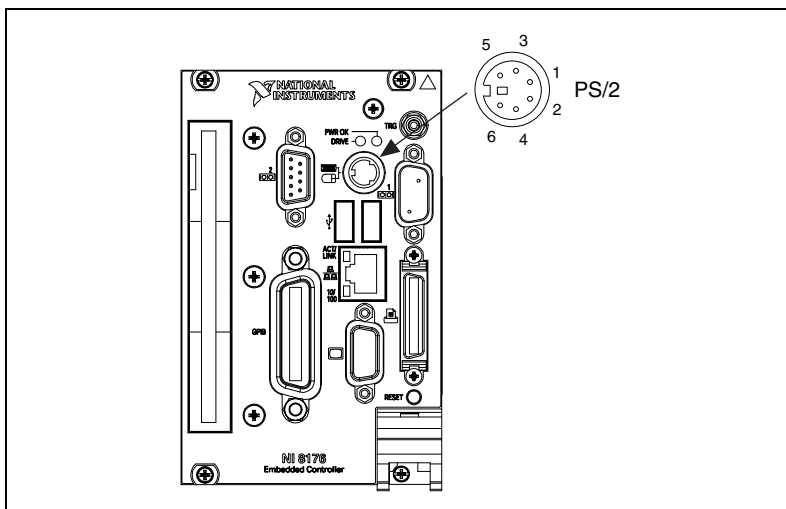

**Figure 3-6.** PS/2 Connector Location and Pinout

**Table 3-7.** PS/2 Connector Signals

Pin	Signal Name	Signal Description	Y-Splitter Keyboard	Y-Splitter Mouse
1	DATA	Data Keyboard	Data Keyboard	Data Mouse
2	NC	Data Mouse	NC	NC
3	GND	Ground	GND	GND
4	+5V	+5 V	+ 5	+ 5
5	CLK	Clock Keyboard	Clock Keyboard	Clock Mouse
6	NC	Clock Mouse	NC	NC



## Trigger

The TRG connector is the software-controlled trigger connection for routing PXI triggers to or from the backplane trigger bus.

Figure 3-7 shows the TRG connector location on the NI 8171 series. Table 3-8 lists and describes the trigger connector signals.

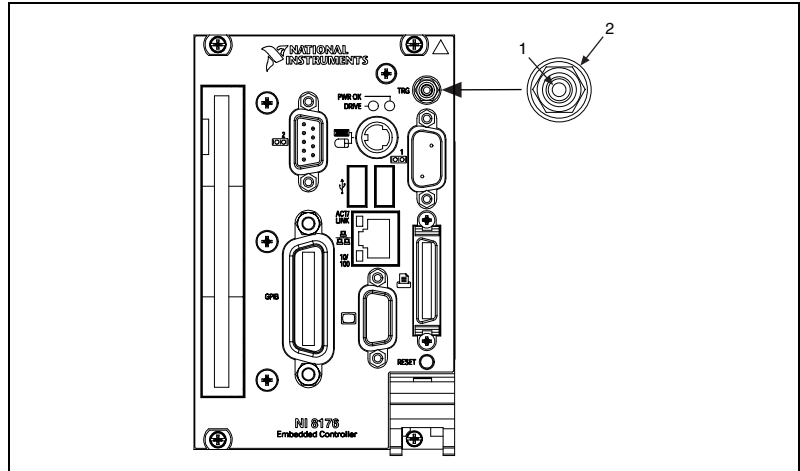

**Figure 3-7.** TRG Connector Location and Pinout

**Table 3-8.** TRG Connector Signals

Pin	Signal Name	Signal Description
1	TRIG	Trigger
2 (Shield)	GND	Ground

## GPIB (IEEE 488.2)

Figure 3-8 shows the location and pinouts for the GPIB connector on the NI 8171 series. Table 3-9 lists and describes the GPIB connector signals.

AMP manufactures a GPIB mating connector, part number 554349-01.

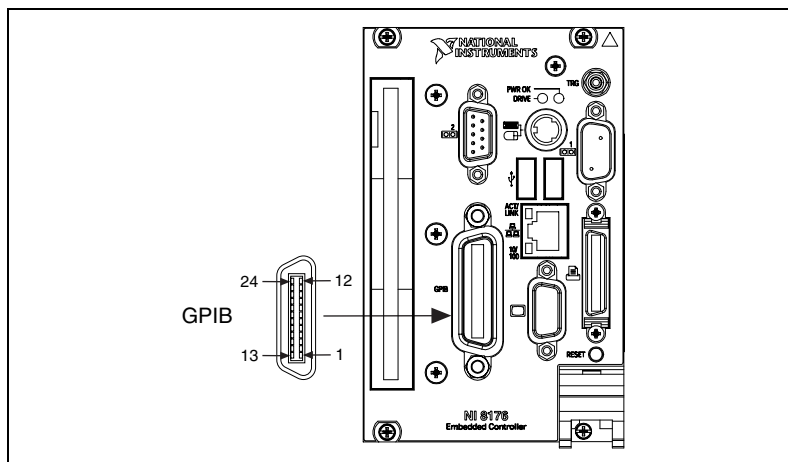

**Figure 3-8.** GPIB Connector Location and Pinout

**Table 3-9.** GPIB Connector Signals

Pin	Signal Name	Signal Description
1	DIO1*	Data Bit 1
2	DIO2*	Data Bit 2
3	DIO3*	Data Bit 3
4	DIO4*	Data Bit 4
5	EOI*	End or Identify
6	DAV*	Data Valid
7	NRFD*	Not Ready for Data
8	NDAC*	Not Data Accepted
9	IFC*	Interface Clear
10	SRQ*	Service Request
11	ATN*	Attention

**Table 3-9.** GPIB Connector Signals (Continued)

Pin	Signal Name	Signal Description
12	SHIELD	Chassis ground
13	DIO5*	Data Bit 5
14	DIO6*	Data Bit 6
15	DIO7*	Data Bit 7
16	DIO8*	Data Bit 8
17	REN*	Remote Enable
18-25	GND	Logic Ground

## Front Panel Features

---

The NI 8171 series has the following front-panel features:

- A system reset pushbutton (hold the button for at least 2 seconds to generate a reset to the controller)
- Two front-panel LEDs that show PC status:
  - The **POWER OK** LED indicates that the power is on and reset is no longer asserted.
  - The **DRIVE** LED indicates when an access to the internal hard disk is occurring.

## Data Storage

---

The NI 8171 series has the following data storage features:

- Internal IDE hard drive
  - 2.5 in. notebook hard drive
  - Supports up to ATA-5 (UDMA 100)
- 1.44 MB floppy disk
- USB storage support—USB CD-ROM or floppy drive

## PXI-1020 and PXI-1025 Chassis Interface

---

The NI 8176 and NI 8175 controllers interface directly to following devices on the National Instruments PXI-1020 and PXI-1025 chassis:

- IDE CD-ROM
- Integrated mouse and keyboard via integrated USB-to-PS2 adapter
- LCD display

For more information, see the [Using the Controllers with PXI-1020 and PXI-1025 Chassis](#) section in Chapter 2, *Installation and Configuration*.

---

# Common Configuration Questions

This chapter answers common configuration questions you may have when using the NI 8171 series embedded controller.

## General Questions

---

### **What do the LEDs on the NI 8171 series front panel mean?**

The green LED indicates the power supplies to/on the NI 8171 series are within spec. The supplies monitored are 3.3 V, 5 V, +12 V, and the internally regulated processor core voltage. The hard drive LED lights when there is hard drive activity on the NI 8171 series.

### **How do I check the configuration of the memory, floppy drive, hard drive, time/date, and so on?**

You can view these parameters in the BIOS setup. To enter the BIOS setup, reboot the NI 8171 series and press <Delete> during the memory tests. See the [Entering BIOS Setup](#) section in Chapter 2, *Installation and Configuration*, for more information.

### **Can I use the internal IDE drive and an external SCSI hard drive at the same time?**

Yes.

## Boot Options

---

### **What devices can I boot from?**

The NI 8171 series can boot from the following devices:

- The internal IDE hard drive.
- The internal 1.44 MB floppy drive.
- The internal IDE CD-ROM in a PXI-1020 or PXI-1025 chassis.
- An external SCSI hard drive or CD-ROM if an SCSI adapter, such as the PXI-8210, is used.

- An external USB mass storage device such as a USB hard drive or CD-ROM.
- An external USB floppy drive.



**Note** There are some limitations when booting from a USB device. Windows does *not* support booting from USB devices. The NI 8171 series BIOS configures the USB devices so they will work in a DOS environment. Due to the Windows limitation, you also cannot install the OS from a USB CD-ROM.

### How do I configure the controller to boot from these devices?

There are two methods:

- Enter Setup and select the **Boot** menu. You will see a list of all bootable devices, ordered by device type. You can set the boot order using <+> and <->. Set the order by device type and set the order for the devices listed within the device type.
- To boot from a different device without permanently changing the boot order, press <Esc> during POST. After the BIOS completes the POST and just before the controller boots the OS, the **Boot** menu is displayed. You can select the device type you want to boot from.

## Cables and Connections

---

### How do I plug both a PS/2 mouse and PS/2 keyboard into the controller?

The NI 8171 series has a combined PS/2 mouse and PS/2 keyboard connector, so you need to use the PS/2 Y-splitter cable shipped with the NI 8171 series, shown in Figure 4-1, to connect both a PS/2 mouse and PS/2 keyboard.

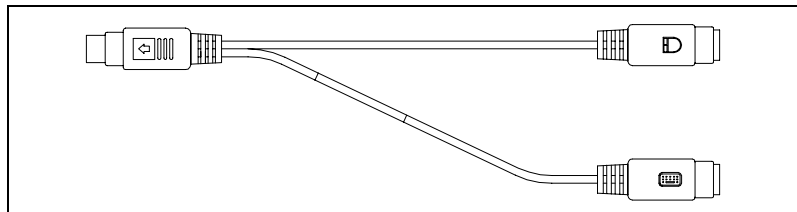

Figure 4-1. Y-Splitter Cable

### How do I get a replacement Y splitter?

See the online catalog at [ni.com](http://ni.com) for ordering details.

**What if I don't have a Y-splitter cable? Can I still use a mouse and keyboard?**

If you do not have a Y-splitter cable, plug a PS/2 keyboard into the PS/2 combo connector. However, you cannot use a PS/2 mouse without the Y-splitter, so use a serial or USB mouse.

**How do I connect a standard 25-pin LPT cable to the NI 8171 series?**

The NI 8171 series uses a type C LPT connector. Most parallel port devices use a type A connector. To use a device with a standard type A LPT connector, you need to use a type C-to-type A LPT adapter. To order the adapter, see the online catalog at [ni.com](http://ni.com).

## Operating System and Software Driver Installation

---

**How do I install or reinstall the video driver?**

See the `Drivers.txt` file on the hard drive or recovery CD-ROM.

**How do I install or reinstall the Ethernet driver?**

See the `Drivers.txt` file on the hard drive or recovery CD-ROM.

**How do I install or reinstall the GPIB driver?**

1. The best way to set up GPIB is to set up networking on your controller so you can access [ni.com](http://ni.com) to download the latest drivers. You can access both of these drivers by going to the current **Drivers and Updates** page.
2. Once these drivers are installed, go into the **Device Manager** in the **System Properties** window, delete the **PCI Bridge** and **PCI Communication Device** entries under **Other Devices**, and reboot the controller.
3. When the controller reboots, it will correctly find and install the proper drivers for the GPIB adapter.

**How do I install software from a CD?**

The compact size of the NI 8171 series does not allow for an integrated CD-ROM drive. If you are using Windows 2000, you have the following options:

- **USB CD-ROM**—Windows 2000 supports USB mass storage devices. With most USB CD-ROM drives, once you plug the drive into the USB port, you should be able to access the drive through a drive letter.

- **SCSI, LPT, or PC card-based CD-ROM**—Other types of CD-ROM drives are available. Check with the vendor to make sure Windows 2000 supports the drive.
- **Mapped network drive**—You can use the Ethernet to connect to another computer. If you share the CD-ROM drive on the other computer, you can map the shared CD-ROM drive to a drive letter on the NI 8171 series.

## Hard Drive Recovery

---

### How do I restore the hard drive image?

The NI 8171 series controllers include a recovery CD. There are two methods for recovering the hard disk to its original state.

### Recovery from a CD-ROM Drive

These steps apply to a USB CD-ROM, IDE CD-ROM (when using a PXI-1020 or PXI-1025 chassis), or SCSI CD-ROM drive (when a SCSI adapter is installed).

To recover the hard disk from a CD-ROM:

1. Load the recovery CD into the CD-ROM drive.
2. Press <Esc> during the BIOS POST. After POST, a boot menu is displayed. Select the CD-ROM drive.
3. The BIOS boots from CD-ROM drive. Follow the prompts to recover the hard drive.



**Note** Not all CD-ROMs are bootable with the NI 8171 series controllers. For a complete list of USB CD-ROM drives that National Instruments has verified as bootable, see [ni.com](http://ni.com).

### Recovery from a Network

To recover the hard disk from a network:

1. Create a DOS boot disk with network support. (The DOS network drivers and a network boot disk example are on the recovery CD.)
2. Use another PC on the network with a CD-ROM drive. Share the drive and load the recovery CD.
3. Boot the NI 8171 series using the network boot disk. Run the net utility from the a drive.



4. Map the shared CD-ROM drive to K:.
5. Run `k:\recover.bat`. Follow the prompts to recover the hard drive.

## Chassis Configuration

---

### How do I set up the NI 8171 series to work with a PXI-1020 or PXI-1025 chassis?

The NI 8176 and NI 8175 controllers interface directly to the National Instruments PXI-1020 and PXI-1025 chassis. The interface contains signals to interface to the chassis LCD display, IDE CDROM drive, and PS/2 mouse and keyboard.

### LCD Display

To enable/disable the LCD display for a PXI-1020 or PXI-1025 chassis:

1. Install the controller in a PXI-1020 or PXI-1025 chassis.
2. Connect a CRT monitor to the VGA connector on the NI 8171 series controller.
3. Power on the chassis and enter the BIOS setup program during the boot. (When the message **Press <DEL> to enter SETUP** appears, press <Delete> or <Del> on the numeric keypad. The message **Entering Setup...** appears, and the setup program is loaded after a short delay.)
4. In the **PXI Setup** menu, set the LCD chassis setting to the correct value.
  - PXI-1020—Enables the LCD display and sets the resolution to 640 × 480.
  - PXI-1025—Enables the LCD display for the PXI-1025 chassis and sets the resolution to 800 × 600.
  - Disabled—Disables the LCD display even if the controller is installed in a PXI-1020 or PXI-1025 chassis.

### IDE CD-ROM Drive

The PXI-1020 and PXI-1025 chassis have integrated CD-ROM drives. The BIOS automatically detects the CD-ROM and enables the IDE interface. The OS loads drivers to access the CD-ROM. Refer to the [Boot Options](#) section for information on booting from the CD-ROM drive.

## Chassis Mouse and Keyboard

The PXI-1020 has an integrated PS/2 mouse. The PXI-1025 has an integrated PS/2 keyboard and mouse. To simplify the configuration for these chassis, the NI 8171 series includes an internal USB-to-PS/2 adapter. When the NI 8171 series is installed in a PXI-1020 or PXI-1025 chassis, the USB-to-PS/2 adapter is enabled automatically. With this adapter, you can use both the chassis' integrated keyboard/mouse and the PS/2 keyboard and mouse connected to the NI 8171 series front panel. To enable keyboard/mouse access in DOS or Windows 2000 environments, you must enable the legacy USB. See the [Boot Options](#) section for more information.

### How do I set up the NI 8171 series to work with my chassis?

A `pxisys.ini` file is associated with each chassis. This file allows software applications such as Measurement & Automation Explorer (MAX) to identify the slot number for each board in the chassis.

You need the correct `pxisys.ini` file for your chassis. You can find these files at [ni.com/support/pxisupp.htm](http://ni.com/support/pxisupp.htm). (Some chassis `.ini` files are also included on the *PXI System Initialization for NI 8171* floppy disk included with the NI-8171 series controller.) Copy the file to the `C:\WINNT` directory.

## Upgrade Information

---

### How do I upgrade system memory?

You can change the amount of installed RAM on the NI 8171 series by upgrading the SO-DIMM.

To upgrade the RAM, remove the NI 8171 series from the PXI chassis. Remove the old SO-DIMM module and install the new SO-DIMM in the socket as shown in Figure 4-2.

National Instruments offers the following types of SO-DIMMs for use with the NI 8171 series controller.

- 128 MB, 16MB × 64, 7.5 ns, 1.05 in. max
- 256 MB, 32MB × 64, 7.5ns, 1.05 in. max



**Note** National Instruments has tested and verified that the SO-DIMMs we sell work with the NI 8171 series. We recommend you purchase your SO-DIMM modules from National Instruments. Other off-the-shelf SO-DIMM modules are not guaranteed to work properly.

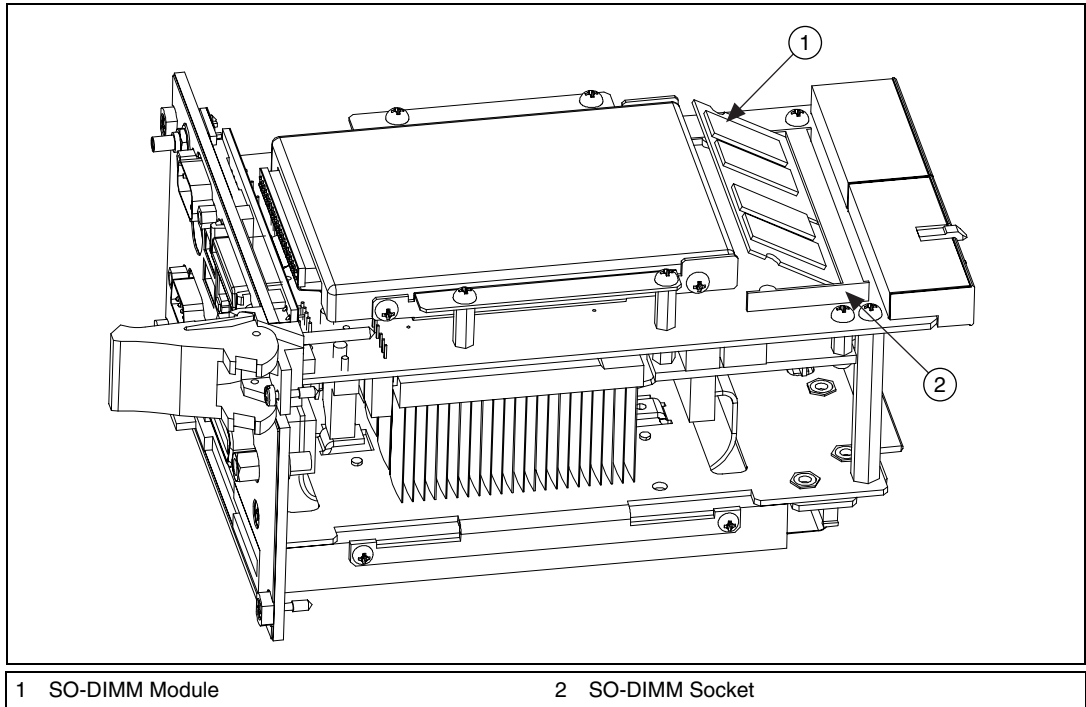

**Figure 4-2.** Installing a SO-DIMM in an NI 8171 Series Controller

### How do I flash a new BIOS?

You need to download the new BIOS from [ni.com/support/pxisupp.htm](http://ni.com/support/pxisupp.htm). To download the new BIOS, follow the instructions on the Web site.

### Where do I get the latest software drivers?

You can download the latest drivers from [ni.com/support/pxisupp.htm](http://ni.com/support/pxisupp.htm).

### My NI 8174 does not have an internal floppy drive. Is there a way to use an external drive?

Yes. The NI 8171 series controllers support and can boot from USB floppy drives. A USB floppy drive will not work with Windows NT4, but will work with Windows 2000. See the [Boot Options](#) section for more information.

The LPT port on the NI 8171 series can also be configured through the BIOS setup for floppy signals instead of LPT signals. See Chapter 3, [I/O Information](#), for the floppy drive pinout.

## Windows NT4 Issues

---

### **Does Windows NT4 support USB and plug and play?**

National Instruments recommends using a USB CD-ROM for software installation when using Windows 2000. However, Windows NT4 does not natively support USB. When using Windows NT4, National Instruments does *not* recommend USB CD-ROMs or other USB devices. (USB keyboards and USB mice will work with Windows NT4 when legacy USB is enabled in the BIOS.)

Windows NT4 is not a plug and play OS. Therefore, driver installation is more difficult on Windows NT4 than on Windows 2000.

## PXI Configuration

---

### **How do I use the SMB trigger on the front panel?**

The SMB connector on the NI 8171 series front panel can connect to or from any PXI backplane trigger line through software. A trigger allocation process is needed to prevent two resources from connecting to the same trigger line, resulting in the trigger being double-driven and possibly damaging the hardware. At the time of this manual's publication, this software is not yet available; however, an interim trigger routing software utility is available from National Instruments. Contact National Instruments for more information.

### **Why doesn't the NI 8171 series work with the PXI-8220?**

A serialized IRQ conflict with the PXI-8220 and the NI 8171 series prevents PC cards using ISA interrupts from working with the NI 8171 series controllers. Contact National Instruments for information about new PC card and cardbus adapters for PXI that work with the NI 8171 series.

---

# Troubleshooting

This chapter answers common troubleshooting questions you may have when using the NI 8171 series embedded computer.

## What if the NI 8171 series does not boot?

Several problems can cause a controller not to boot. Here are some things to look for and possible solutions.

### Things to Notice

- Which LEDs come on? The **Power OK** LED should stay lit. The **Drive** LED should blink during boot as the disk is accessed.
- What appears on the display? Does it hang at some particular point (BIOS, Operating System, etc.)? If nothing appears on the screen, try a different monitor. Does your monitor work with a different PC? If it hangs, note the last screen output that you saw for reference when consulting National Instruments technical support.
- What has changed about the system? Did you recently move the system? Was there electrical storm activity? Did you recently add a new module, memory chip, or piece of software?

### Things to Try

- Make sure the chassis is plugged in to a working power source.
- Check any fuses or circuit breakers in the chassis or other power supply (possibly a UPS).
- Make sure the controller module is firmly seated in the chassis.
- Remove all other modules from the chassis.
- Remove any nonessential cables or devices.
- Try the controller in a different chassis.
- Try a similar controller in this same chassis.
- Recover the hard drive on the controller. (See the [Hard Drive Recovery](#) section in Chapter 4, [Common Configuration Questions](#).)
- Clear the CMOS. (See the [System CMOS](#) section in Chapter 2, [Installation and Configuration](#).)

**My controller boots fine until I get to Windows, at which point I cannot read the screen. This may include garbled output, white screen, black screen, or an out of synch message from the monitor.**

This problem usually results from having the video card output set past the limits of the monitor. You will need to boot Windows in Safe Mode. To do this, reboot the controller. As Windows begins to boot, hold down <F8>. For Windows NT, select **Windows NT (VGA MODE)** from the boot manager. You should now be able to reset the video driver to lower settings. Try setting the resolution to 640x480 and the refresh rate to 60Hz. Once you reboot, you can raise these values again, using the test option in Windows. These settings are accessible through the **Advanced** tab of the **Display** item in the **Control Panel**. Alternately, you can try a different monitor, preferably a newer and larger one.

**My system boots fine as long as a particular module is not in my chassis.**

The most common cause of this is a damaged module. Try the module in a different chassis or with a different controller. Also, remove any external cables or terminal blocks connected to the system. If the module does not work in these cases, it is likely damaged. Contact the module manufacturer for further troubleshooting.

See the KnowledgeBase or product manuals section at [ni.com](http://ni.com) for more information specific to the chassis and controller with which you are having difficulties.

**How do I restore the operating system on a my NI 8171 series controller?**

The NI 8171 series controllers include a recovery CD. There are two methods for recovering the hard disk to its original state—recovery from a CD-ROM or from a network. For more information, see the [Recovery from a CD-ROM](#) or [Recovery from a Network](#) sections in Chapter 2, *Installation and Configuration*.

**My CMOS is corrupted. How do I set it back to default?**

1. Enter the BIOS setup program as described in the [Entering BIOS Setup](#) section of Chapter 2, *Installation and Configuration*.
2. Press <F9> to load BIOS defaults.
3. Answer **Y** (Yes) to the verification prompt.
4. Select **Save and Exit Setup**.

**I can't change the display on the NI 8171 series controller from 640 × 480 to 800 × 600. What's wrong?**

If you are using a PXI-1020 or PXI-1025 chassis, the integrated LCD limits the maximum resolution displayed.

If you are not using a PXI-1020 or PXI-1025 chassis, be sure the video driver is installed. If it is not, see the `Drivers.txt` file on the hard drive or recovery CD-ROM.

**What if there is a power loss during a BIOS update?**

Create a crisis recovery disk. Unzip `crisis.zip` on the recovery CD. Insert a blank floppy disk in the PC. Run `crisis.exe` (or `wincrisis.exe` in Windows). Follow the instructions to create the BIOS recovery floppy disk. Insert the disk in the NI 8175 or NI 8176 floppy drive and power on the controller. The controller installs the BIOS from the disk.

## Specifications

This appendix lists the electrical, mechanical, and environmental specifications of the NI 8171 series embedded computers.

### NI 8176

#### Electrical

Voltage (V)	Current (A)	
	Typical	Maximum
+3.3	3 A	4 A
+5	3.8 A	6 A
+12	0.01 A	0.05 A
-12	0 A	0 A

#### Physical

Board dimensions.....	PXI 3U-size module 8.1 by 13 by 21.6 cm (3.2 by 5.1 by 8.5 in.)
Slot requirements .....	One system slot plus three controller expansion slots
Compatibility .....	Fully compatible with PXI specification
MTBF.....	169,000 h
Weight.....	1.18 Kg (2.6 lb) typical



## Environmental

Temperature .....	0° to 50° C operating –20° to 65° C storage
Relative humidity .....	10% to 90% noncondensing, operating 5% to 95% noncondensing, storage
EMI .....	FCC Class A verified, EC verified
Functional shock .....	30 g peak, half-sine, 11 ms pulse
Random vibration .....	5 to 500 Hz, 0.3 g <sub>rms</sub> , operating 5 to 500 Hz, 2.4 g <sub>rms</sub> , nonoperating



**Note** For full EMC compliance, you must operate this device with shielded cabling. In addition, all covers and filler panels must be installed. Refer to the Declaration of Conformity (DoC) for this product for any additional regulatory compliance information. To obtain the DoC for this product, click **Declaration of Conformity** at [ni.com/hardref.nsf/](http://ni.com/hardref.nsf/). This Web site lists the DoCs by product family. Select the appropriate product family, followed by your product, and a link to the DoC appears in Adobe Acrobat format. Click the Acrobat icon to download or read the DoC.

## NI 8175

---

### Electrical

Voltage (V)	Current (A)	
	Typical	Maximum
+3.3	3.2 A	4.7 A
+5	3.5 A	6 A
+12	0.01 A	0.05 A
–12	0 A	0 A

## Physical

Board dimensions.....	PXI 3U-size module 8.1 by 13 by 21.6 cm (3.2 by 5.1 by 8.5 in.)
Slot requirements .....	One system slot plus three controller expansion slots
Compatibility .....	Fully compatible with PXI specification
MTBF.....	180,000 h
Weight.....	1.07 Kg (2.35 lb) typical

## Environmental

Temperature .....	0° to 50° C operating –20° to 60° C storage
Relative humidity .....	20% to 80% noncondensing, operating 5% to 95% noncondensing, storage
EMI .....	FCC Class A verified, EC verified
Functional shock .....	30 g peak, half-sine, 11 ms pulse
Random vibration.....	5 to 500 Hz, 0.3 g <sub>rms</sub> , operating 5 to 500 Hz, 2.4 g <sub>rms</sub> , nonoperating



**Note** For full EMC compliance, you must operate this device with shielded cabling. In addition, all covers and filler panels must be installed. Refer to the Declaration of Conformity (DoC) for this product for any additional regulatory compliance information. To obtain the DoC for this product, click **Declaration of Conformity** at [ni.com/hardref.nsf/](http://ni.com/hardref.nsf/). This Web site lists the DoCs by product family. Select the appropriate product family, followed by your product, and a link to the DoC appears in Adobe Acrobat format. Click the Acrobat icon to download or read the DoC.

# NI 8174

---

## Electrical

Voltage (V)	Current (A)	
	Typical	Maximum
+3.3	3 A	4.3 A
+5	2 A	3.5 A
+12	0.01 A	0.05 A
-12	0 A	0 A

## Physical

Board dimensions .....	PXI 3U-size module 6.1 by 13 by 21.6 cm (2.4 by 5.1 by 8.5 in.)
Slot requirements .....	One system slot plus three controller expansion slots
Compatibility .....	Fully compatible with PXI specification
MTBF .....	226,000 h
Weight .....	0.64 Kg (1.41 lb) typical

## Environmental

Temperature .....	0° to 50° C operating -20° to 60° C storage
Relative humidity .....	20% to 80% noncondensing, operating 5% to 95% noncondensing, storage
EMI .....	FCC Class A verified, EC verified
Functional shock .....	30 g peak, half-sine, 11 ms pulse

Random vibration..... 5 to 500 Hz, 0.3 g<sub>rms</sub>, operating  
5 to 500 Hz, 2.4 g<sub>rms</sub>,  
nonoperating



**Note** For full EMC compliance, you must operate this device with shielded cabling. In addition, all covers and filler panels must be installed. Refer to the Declaration of Conformity (DoC) for this product for any additional regulatory compliance information. To obtain the DoC for this product, click **Declaration of Conformity** at [ni.com/hardref.nsf/](http://ni.com/hardref.nsf/). This Web site lists the DoCs by product family. Select the appropriate product family, followed by your product, and a link to the DoC appears in Adobe Acrobat format. Click the Acrobat icon to download or read the DoC.

---

## Technical Support Resources

### Web Support

---

National Instruments Web support is your first stop for help in solving installation, configuration, and application problems and questions. Online problem-solving and diagnostic resources include frequently asked questions, knowledge bases, product-specific troubleshooting wizards, manuals, drivers, software updates, and more. Web support is available through the Technical Support section of [ni.com](http://ni.com).

### NI Developer Zone

---

The NI Developer Zone at [ni.com/zone](http://ni.com/zone) is the essential resource for building measurement and automation systems. At the NI Developer Zone, you can easily access the latest example programs, system configurators, tutorials, technical news, as well as a community of developers ready to share their own techniques.

### Customer Education

---

National Instruments provides a number of alternatives to satisfy your training needs, from self-paced tutorials, videos, and interactive CDs to instructor-led hands-on courses at locations around the world. Visit the Customer Education section of [ni.com](http://ni.com) for online course schedules, syllabi, training centers, and class registration.

### System Integration

---

If you have time constraints, limited in-house technical resources, or other dilemmas, you may prefer to employ consulting or system integration services. You can rely on the expertise available through our worldwide network of Alliance Program members. To find out more about our Alliance system integration solutions, visit the System Integration section of [ni.com](http://ni.com).

## Worldwide Support

---

National Instruments has offices located around the world to help address your support needs. You can access our branch office Web sites from the Worldwide Offices section of [ni.com](http://ni.com). Branch office Web sites provide up-to-date contact information, support phone numbers, e-mail addresses, and current events.

If you have searched the technical support resources on our Web site and still cannot find the answers you need, contact your local office or National Instruments corporate. Phone numbers for our worldwide offices are listed at the front of this manual.

# Glossary

---

Prefix	Meaning	Value
n-	nano-	$10^{-9}$
$\mu$ -	micro-	$10^{-6}$
m-	milli-	$10^{-3}$
k-	kilo-	$10^3$
M-	mega-	$10^6$
G-	giga-	$10^9$
t-	tera-	$10^{12}$

## Symbols

° degrees

$\Omega$  ohms

% percent

## A

A amperes

AC Alternating Current

ASIC application-specific integrated circuit

## B

B bytes

backplane An assembly, typically a printed circuit board, with connectors and signal paths that bus the connector pins.

**BIOS** Basic Input/Output System. BIOS functions are the fundamental level of any PC or compatible computer. BIOS functions embody the basic operations needed for successful use of the computer's hardware resources.

## **C**

**C** Celsius

**cache** Small portion of high-speed memory used for temporary storage of frequently used data

**CMOS** Complementary Metal Oxide Semiconductor; a process used in making chips

**CompactPCI** An adaptation of the PCI specification for industrial and/or embedded applications that require a more robust mechanical form factor than desktop PCI. CompactPCI provides a standard form factor for those applications requiring the high performance of PCI as well as the small size and ruggedness of a rack-mount system.

## **D**

**DC** Direct Current

**DIMM** Dual In-line Memory Module

**DMA** Direct Memory Access; a method by which data is transferred between devices and internal memory without intervention of the central processing unit

**DRAM** Dynamic RAM (Random Access Memory); storage that the computer must refresh at frequent intervals

## **E**

**ECP** Extended Capabilities Parallel

**EDO** Extended Data Out

**EEPROM** Electronically Erasable Programmable Read Only Memory



embedded controller	An intelligent CPU (controller) interface plugged directly into the PXI backplane, giving it direct access to the PXI bus. It must have all of its required PXI interface capabilities built in.
EMC	Electromagnetic Compatibility
EMI	electromagnetic interference
EPP	Enhanced Parallel Port
expansion ROM	An onboard EEPROM that may contain device-specific initialization and system boot functionality

**F**

FCC	Federal Communications Commission
-----	-----------------------------------

**G**

g	<ol style="list-style-type: none"> <li>1. grams</li> <li>2. A measure of acceleration equal to 9.8 m/s<sup>2</sup>.</li> </ol>
GPIB	General Purpose Interface Bus (IEEE 488)
$g_{RMS}$	A measure of random vibration. The root mean square of acceleration levels in a random vibration test profile.

**H**

Hz	hertz; cycles per second
----	--------------------------

**I**

IDE	Integrated Drive Electronics; hard disk and built-in controller
IEEE	Institute of Electrical and Electronics Engineers
in.	inches

instrument driver	A set of routines designed to control a specific instrument or family of instruments, and any necessary related files for LabWindows/CVI or LabVIEW
interrupt	A means for a device to request service from another device
interrupt level	The relative priority at which a device can interrupt
I/O	input/output; the techniques, media, and devices used to achieve communication between machines and users
IRQ*	Interrupt signal
ISA	Industry Standard Architecture; the original PC bus architecture, specifically the 16-bit AT bus
<b>K</b>	
KB	kilobytes of memory
<b>L</b>	
LAN	Local Area Network; communications network that serves users within a confined geographical area. It is made up of servers, workstations, a network operating system, and a communications link.
LED	light-emitting diode
<b>M</b>	
m	meters
master	A functional part of a PXI device that initiates data transfers on the PXI backplane. A transfer can be either a read or a write.
MB	megabytes of memory
MTBF	Mean time between failure
MTTR	Mean time to repair

**N**

NI-488 or NI-488.2	The National Instruments software for GPIB systems
NI-DAQ	The National Instruments software for data acquisition instruments
NI-VISA	The National Instruments implementation of the VISA standard; an interface-independent software that provides a unified programming interface for VXI, GPIB, and serial instruments
NMI	Non-maskable interrupt; high-priority interrupt that cannot be disabled by another interrupt. It is used to report malfunctions such as parity, bus and math coprocessor errors.

**P**

PCI	Peripheral Component Interconnect. The PCI bus is a high-performance 32-bit or 64-bit bus with multiplexed address and data lines.
PCMCIA	Personal Computer Memory Card International Association
peripheral	any hardware device connected to a computer, such as a monitor, keyboard, printer, plotter, disk or tape drive, graphics tablet, scanner, mouse, and so on
POSC	Power On Self Configuration
PXI	PCI eXtensions for Instrumentation; an open implementation of CompactPCI that adds electrical features that meet the high-performance requirements of instrumentation applications by providing triggering, local buses, and system clock capabilities. PXI also offers two-way interoperability with CompactPCI products.

**R**

RAM	Random Access Memory; the computer's primary workspace
RAMDAC	Random Access Memory Digital to Analog Converter; the VGA controller chip that maintains the color palette and converts data from memory into analog signals for the monitor
resource	hardware settings used by devices in a computer system, including ISA interrupt level, DMA channel, and I/O address

RMS	Root mean squared. <i>See</i> <a href="#">gRMS</a> .
RTC	Real Time Clock; an electronic circuit that maintains the time of day, and can also provide timing signals for timesharing operations

## S

s	seconds
slave	A functional part of a PXI device that detects data transfer cycles initiated by a PXI bus master and responds to the transfers when the address specifies one of the device's registers
SO-DIMM	Small Outline Dual In-line Memory Module
SRAM	Static RAM; a memory chip that requires power to hold its content. It does not require refresh circuitry as a dynamic RAM chip, but it does take up more space and uses more power.
ST	Start Trigger
Star Trigger Slot	This slot is located at Slot 2 in a PXI mainframe and has a dedicated trigger line between each peripheral slot. This slot would be used for a module with ST functionality that can provide individual triggers to all other peripherals.

## U

USB	Universal Serial Bus
-----	----------------------

## V

V	Volts
VGA	Video Graphics Array; the minimum video display standard for all PCs

## W

W	Watts
---	-------

# Index

---

## A

Advanced Setup menu, 2-5

## B

### BIOS

checking settings, 4-1

flashing new BIOS, 4-7

power loss during update, 5-3

setup

Advanced Setup menu, 2-5

Boot Setup menu, 2-8

DMI Event Logging menu, 2-5

entering, 2-3

Exiting BIOS Setup menu, 2-9

Integrated Peripherals menu, 2-6

Main Setup menu, 2-4

PXI Setup menu, 2-7

Security Setup menu, 2-8

boot options

configuring controller, 4-2

Boot Setup menu, 2-8

## C

### CD-ROM drive

for PXI-1020 and PXI-1025, 2-11

installing software from, 4-3

chip set north bridge, 1-4

chip set south bridge, 1-4

### CMOS

clearing contents (figure), 2-10

setting back to default, 5-2

### COM1 and COM2 connectors

connector locations and pinout (figure), 3-3

connector signals (table), 3-3

### common configuration questions

boot options, 4-1

cables and connections, 4-2

chassis configuration, 4-5

driver installation, 4-3

general questions, 4-1

hard drive recovery, 4-4

operating system, 4-3

PXI configuration, 4-8

upgrade information, 4-6

Windows NT4, 4-8

CompactPCI specification, 1-1

ComponentWorks, 1-6

ComponentWorks++, 1-6

### configuration

#### common questions

boot options, 4-1

cables and connections, 4-2

chassis configuration, 4-5

driver installation, 4-3

general questions, 4-1

hard drive recovery, 4-4

operating system, 4-3

PXI configuration, 4-8

upgrade information, 4-6

Windows NT4, 4-8

### connectors

COM1 and COM2 connectors and signals, 3-3

Ethernet connector and signals, 3-4

GPIB connector and signals, 3-10

parallel port connector and signals, 3-5

peripheral expansion overview (table), 3-1

PS/2 connector and signals, 3-8

trigger connector and signals, 3-9

- Universal Serial Bus (USB) connector and signals, 3-7
- VGA connector and signals, 3-2
- conventions used in the manual, *xi*
- customer education, B-1

## D

- data storage, 3-11
- directories and files installed on hard drive, 2-12
- DMI Event Logging menu, 2-5
- documentation
  - how to use this documentation set, *xi*
- DRIVE LED, 3-11
- drivers, 2-12
  - installation
    - GPIB (IEEE 488.2), 4-3
    - video, 4-3
  - obtaining latest drivers, 4-7

## E

- Ethernet,
  - connector
    - location and pinout (figure), 3-4
    - signals (table), 3-5
- Exiting BIOS Setup menu, 2-9

## F

- files and directories installed on hard drive, 2-12
- floppy drive
  - using external floppy drive, 4-7
- front panel
  - connectors, 3-1
  - features, 3-11
- functional overview of NI 8171 series, 1-2

## G

- GPIB (IEEE 488.2), 3-10
  - connector location and pinout (figure), 3-10
  - connector signals (table), 3-10
  - driver installation, 4-3

## H

- hard drive, 3-11
  - files and directories installed on, 2-12
  - recovery, 2-14, 5-2
    - from network, 2-15
    - from USB CD-ROM, 2-14
  - restoring image, 4-4

## I

- IDE controller
  - using SCSI hard drive in addition, 4-1
- IDE logic block, 1-4
- IEEE 488.2, 3-10
- images directory, 2-12
- installation
  - See also* configuration
  - injector/ejector handle position (caution), 2-1
  - NI 8171 series installed in a PXI chassis (figure), 2-2
  - procedure, 2-1
  - removing NI 8171 series from PXI chassis, 2-3
- Integrated Peripherals menu, 2-6

## K

- keyboard
  - for PXI-1020 and PXI-1025, 2-12
  - plugging PS/2 mouse and keyboard into controller, 4-2

keyboard and mouse  
 logic block, 1-4  
 overview (table), 3-1

## L

LabVIEW, 1-5  
 LabWindows/CVI, 1-6  
 LCD display  
 for PXI-1020 and PXI-1025, 2-11  
 LEDs  
 front panel LEDs, 3-11, 4-1  
 LPT cable  
 connecting to 8171 series, 4-3

## M

Main Setup menu, 2-4  
 manuals directory, 2-12  
 mating connector  
 COM1 and COM2, 3-3  
 Ethernet, 3-4  
 GPIB (IEEE 488.2), 3-10  
 parallel port, 3-5  
 USB, 3-7  
 VGA, 3-2  
 Measurement Studio, 1-5  
 mouse  
 for PXI-1020 and PXI-1025, 2-12  
 plugging PS/2 mouse and keyboard into  
 controller, 4-2

## N

National Instruments software, 1-5  
 National Instruments Web support, B-1  
 NI 8171 series  
 benefits of PXI, 1-1  
 BIOS setup, 2-3  
 block diagram, 1-3

connectors, 3-1  
 COM1 and COM2 connectors and  
 signals, 3-3  
 GPIB (IEEE 488.2) connector and  
 signals, 3-10  
 parallel port connector and  
 signals, 3-5  
 PS/2 connector and signals, 3-8  
 trigger connector and signals, 3-9  
 Universal Serial Bus (USB)  
 connector and signals, 3-7  
 VGA connector and signals  
 (table), 3-2  
 data storage, 3-11  
 front panel  
 features, 3-11  
 LEDs, 4-1  
 system reset pushbutton, 3-11  
 functional overview, 1-2  
 hard drive recovery, 2-14, 5-2  
 installing in a PXI chassis, 2-1  
 (figure), 2-2  
 installing SO-DIMMs (figure), 2-14, 4-7  
 logic blocks, 1-4  
 modules, 1-2  
 National Instruments software, 1-5  
 peripheral expansion overview  
 (table), 3-1  
 PXI trigger connectivity, 2-13  
 removing from a PXI chassis, 2-3  
 software, 1-5  
 specifications, A-1  
 troubleshooting, 5-1  
 upgrading RAM, 2-13, 4-6  
 using external floppy drive with, 4-7  
 using with chassis, 4-6  
 using with PXI-1020 and PXI-1025,  
 2-11, 3-12, 4-5  
 NI 8174, 1-2  
 specifications, A-4

- NI 8175, 1-2
  - specifications, A-2
- NI 8176, 1-2
  - specifications, A-1
- NI Developer Zone, B-1
- NI-DAQ function library, 1-5
- NI-VISA high-level programming API, 1-5

## O

- os directory, 2-12
- OS installation
  - from CD-ROM, 2-15
  - from network, 2-16

## P

- parallel port,
  - connector location and pinout (figure), 3-5
  - connector signals (table), 3-6
  - overview (table), 3-1
- PCI bus
  - standard for desktop computer designs, 1-1
- peripheral expansion overview (table), 3-1
- plug and play
  - Windows NT4 support, 4-8
- POWER OK LED, 3-11
- PS/2
  - connector location and pinout (figure), 3-8
  - connector signals (table), 3-8
  - plugging PS/2 mouse and keyboard into controller, 4-2
- PXI connectors
  - function (logic block), 1-4
- PXI features, 2-13
- PXI Setup menu, 2-7
- PXI trigger connectivity, 2-13

- PXI-1020 and PXI-1025
  - using NI 8171 series with, 2-11, 3-12, 4-5
- PXI-8220
  - using NI 8171 series with, 4-8
- pxisys.ini file, 4-6

## R

- RAM
  - SO-DIMMs from National Instruments (note), 2-13, 4-6
  - upgrading, 2-13, 4-6
- related documentation, *xii*

## S

- Security Setup menu, 2-8
- serial ports, 3-1
  - See also* COM1 and COM2 connectors
- slot 1 CPU, 1-4
- SO-DIMM logic block, 1-4
- SO-DIMMs
  - from National Instruments (note), 2-13, 4-6
  - installing, 2-13, 4-6 (figure), 2-14, 4-7
- software
  - See also* drivers
  - ComponentWorks, 1-6
  - ComponentWorks++, 1-6
  - installed on your hard drive, 2-12
  - installing from CD-ROM, 4-3
  - LabVIEW, 1-5
  - LabWindows/CVI, 1-6
  - Measurement Studio, 1-5
  - National Instruments software, 1-5
  - NI-DAQ, 1-5
  - NI-VISA, 1-5



## specifications

NI 8174, A-4

NI 8175, A-2

NI 8176, A-1

super I/O logic block, 1-4

system CMOS, 2-10

system integration, by National Instruments, B-1

system reset pushbutton, 3-11

**T**

technical support resources, B-1

trigger, 3-9, 4-8

connector location and pinout  
(figure), 3-9

connector signals (table), 3-9

troubleshooting

CMOS reset, 5-2

controller does not boot, 5-1

damaged module, 5-2

hard drive recovery, 5-2

power loss during BIOS update, 5-3

video display, 5-2, 5-3

**U**

Universal Serial Bus (USB), 3-1, 3-7

connector function, 1-4

connector location and pinout  
(figure), 3-7

connector signals (table), 3-7

overview (table), 3-1

Windows NT4 support, 4-8

**V**

VGA

connector signals (table), 3-2

location and pinout (figure), 3-2

overview (table), 3-1

video, 3-1

*See also* VGA

changing resolution, 5-3

driver installation, 4-3

**W**

Web support from National Instruments, B-1

Windows NT4

support for USB and plug and play, 4-8

worldwide technical support, B-2

**Y**

Y splitter

figure, 4-2

obtaining replacement, 4-2

using mouse and keyboard without, 4-3

using with PS/2 mouse and keyboard,  
2-2, 3-8