



# MODEL: RB36 GAS SALAMANDER BROILER



Model RB36



CSA design certified. NSF listed.

**BASIC MODEL:**

**RB36** Gas salamander broiler.

**KEY FEATURES:**

- Stainless steel front, top and sides.
- Six 11,000 BTU/hr bar-type burners with stainless steel radiants; 66,000 BTU/hr total input.
- Infinite heat control valve.
- Standing pilot ignition system.
- Chrome plated trigger grip control handle provides positive positioning of the broiling carriage. Heavy-duty chrome plated broiling grid measures 27½"w x 13"d.
- Removable full width spillage pan.
- ¾" top gas connection and gas pressure regulator.
- One year limited parts and labor warranty.

**OPTIONAL FEATURES:**

- Set of chrome wall mount brackets.
- Set of four 4" legs with adjustable feet.

**DESCRIPTION:**

Gas salamander broiler, Wolf Model No. RB36. Six 11,000 BTU/hr bar-type burners with stainless steel radiants; 66,000 BTU/hr total input. Infinite heat control valve. Pilot ignition system. Chrome plated trigger grip control handle provides positive positioning of the broiling carriage. Heavy-duty chrome plated broiling grid measures 27½"w x 13"d. Removable full width spillage pan. ¾" top gas connection and gas pressure regulator. Exterior dimensions: 36"w x 19"d x 17½"h.

Approved by \_\_\_\_\_

Date: \_\_\_\_\_

**SPECIFY TYPE OF GAS WHEN ORDERING.  
SPECIFY ALTITUDE WHEN ABOVE 2,000 FT.**

**WOLF RANGE COMPANY**

Wolf Range Company  
Division of ITW Food Equipment Group LLC  
(800) 366-9653  
www.wolfrange.com



## Model RB36 Gas Salamander Broiler

### INSTALLATION REQUIREMENTS:

1. A gas pressure regulator sized for this unit is included. Natural Gas 5.0" W.C. Propane Gas 10.0" W.C.
2. Gas line connecting to appliance must be 3/4" diameter or larger. If flexible connectors are used, the inside diameter must be the same as the 3/4" iron pipe.
3. An adequate ventilation system is required for commercial cooking equipment. Information may be obtained by writing to the National Fire Protection Association, 1 Batterymarch Park, Quincy, MA 02169, www.NFPA.org. When writing, refer to NFPA No. 96.
4. These units are manufactured for installation in accordance with National Fuel Gas Code, ANSI-Z223.1/NFPA #54 (latest edition). Copies may be obtained from The American Gas Association, Accredited Standards Committee Z223

@ 400N. Capital St. NW, Washington, DC 20001, or the Secretary Standards Council, NFPA, 1 Batterymarch Park, Quincy, MA 02169-7471.

#### NOTE: In the Commonwealth of Massachusetts

All gas appliances vented through a ventilation hood or exhaust system equipped with a damper or with a power means of exhaust shall comply with 248 CMR.

5. Clearances:

	Combustible	Non-Combustible
Rear	0"	0"
Sides	6"	0"
Bottom	10"	4"

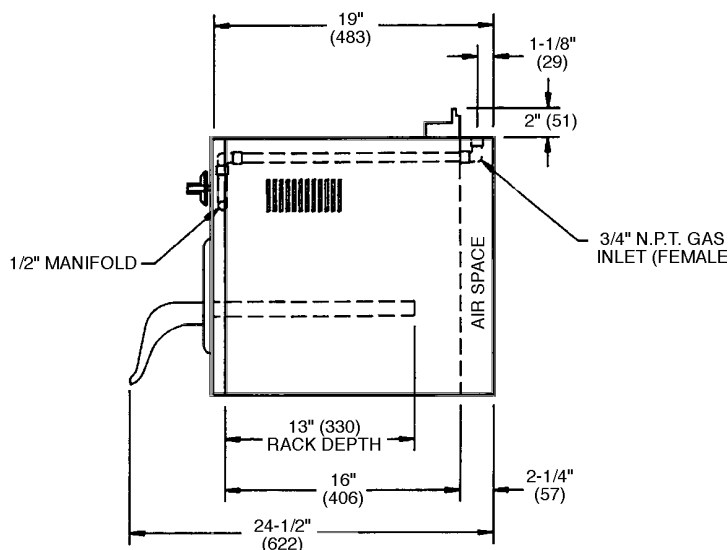
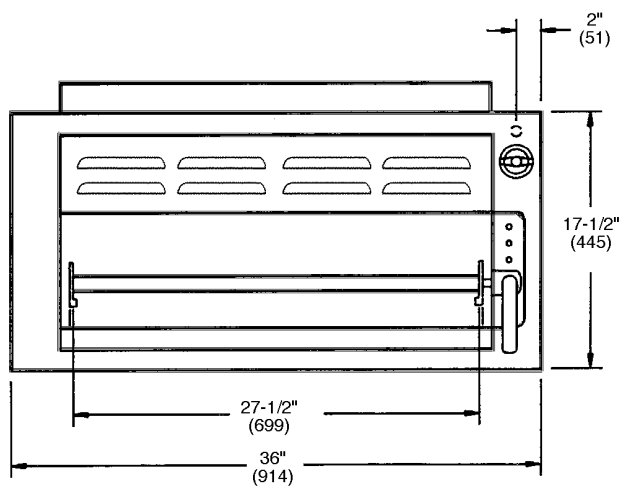

Model No.	Width	Depth	Height	Grid Rack (w x d)	No. of Burners	Total BTU/hr.	Approx. Shp. Wt. (lbs./kg)
RB36	36"	19"	17½"	27½" x 13"	6	66,000	180/81

**NOTE: In line with its policy to continually improve its product, Wolf Range Company reserves the right to change materials and specifications without notice.  
This appliance is manufactured for commercial use only and is not intended for home use.**