

ÖKO-ARCTIS SUPER 3173-4GS



Electronic Freezers

Operating Instructions

Dear customer,

Before placing your new refrigerator/freezer into operation please read these operating instructions carefully. They contain important information for safe use, for installation and for care of the appliance.

Please keep these operating instructions for future reference. Pass them on to possible new owners of the appliance.

These operating instructions are for use with several technically comparable models with varying accessories. Please observe the notes which apply to your model.



Notes which are important for your safety or for the proper functioning of the appliance are stressed with a warning triangle and/or with signal words (**Warning!**, **Caution!**, **Attention!**). Please observe the following carefully.



This symbol guides you step by step in the operation of the appliance.



Supplementary information regarding operation and practical applications of the appliance appear after this symbol.



Tips and notes concerning economical and environmentally sound use of the appliance are marked with the cloverleaf.

Explanations of the technical terminology used in the operating instructions can be found at the end in the section "Technical Terminology".

The operating instructions contain instructions for the correction of possible malfunctions by the user in the section "What to do if ...". If these instructions should not be sufficient, our customer service department is always available to you.

Printed on paper manufactured with environmentally sound processes.
he who thinks ecologically acts accordingly ...

Contents

Safety	5
Disposal	7
Appliance Packaging Information	7
Disposal of old Appliances	7
Appliance Transport	8
Remove transport safeguard	9
Installation	10
Installation Location	10
The refrigerator or freezer needs air	11
Appliance Alignment	11
Electrical connection	12
Opening the door	13
Re-Hanging Door	14
1. Appliances with base cover	14
2. Appliances without base cover	15
Door Alignment	16
Appliance Description	18
View of Appliance	18
Interior Illumination	19
Freezer tray	19
Ice Packs	19
Control Panel	20
Temperature Regulator	20
Temperature Display	21
FAST FREEZE Button	21
Prior to Initial Start-Up	22
Initial Start-Up	22
Temperature Adjustment	23
Switching the Appliance Off	24

Control and Information Systems	25
"Open Door"-Warning (not included with all models!)	25
Power Interruption (not included with all models!)	25
Temperature Warning	25
Partial/Complete Thaw Warning	26
Function Errors	26
Freezing	27
Frozen Storage	28
Preparation of Ice Cubes	29
Storage Goods Symbols/Freezing Calendar	29
Maximum Load/Stacking Limit	30
Defrosting	30
Cleaning and Care	31
Energy Saving Tips	32
What to do if	33
Correcting Malfunctions	33
Interior Illumination	36
Replace light bulb	36
Adjust door contacter	36
Customer Service	37
Noises during Operation	38
Regulations, Standards, Guidelines	38
Technical Terminology	39

Safety

The safety of our freezers is in accordance with recognised technological standards and appliance safety legislation. We nevertheless feel that it is important to acquaint you with the following safety guidelines:

Use for Intended Purpose

- The freezer is intended for household use. It is suited for the freezing and frozen storage of foods as well as the preparation of ice. The manufacturer assumes no liability for damages occurring through improper operation or use of the appliance for unintended purposes.
- Alterations or changes to the freezer are not permitted for reasons of safety.
- If you use the freezer in a commercial application or for purposes other than the freezing or frozen storage of foods, please observe all valid legal regulations for your application.

Prior to initial start-up

- Check the refrigerator/freezer for transport damage. Do not under any circumstances connect a damaged appliance! Please contact your supplier in the event of damage.

Refrigerant

The refrigerant isobutane (R600a) is contained within the refrigerant circuit of the appliance, a natural gas with a high level of environmental compatibility, which is nevertheless flammable.

- During transportation and installation of the appliance, be certain that none of the components of the refrigerant circuit become damaged.
- If the refrigerant circuit should become damaged:
 - avoid open flames and sources of ignition;
 - thoroughly ventilate the room in which the appliance is situated.

Safety for Children

- Packaging materials (e.g. films, styrofoam) can be dangerous for children. Danger of suffocation! Keep packaging materials away from children!
- Before disposing of old appliances make them inoperable. Remove plug from mains, sever the power cable, remove or destroy any snap or latch closures. This eliminates the danger that playing children lock themselves into the appliance (danger of suffocation!) or place themselves into other life-endangering situations.

- Children often do not recognise the dangers involved with household appliances. Please provide for the necessary supervision and do not allow children to play with the appliance!

Daily Operation

- Containers with flammable gases or fluids can develop leaks through contact with the cold. Danger of explosion! Do not store containers with flammable substances, such as in the refrigerator/freezer. aerosol cans, refill cartridges for cigarette lighters etc.
- Bottles and cans may not be placed in the freezer compartment. They can burst when the contents freeze - or even explode if the contents contain carbonic acid! Never place sodas, juices, beer, wine, champagne etc. into the freezer compartment. Exception: Spirits with high alcohol content may be stored in the freezer compartment.
- Do not place ice cream or ice cubes directly from the freezer compartment into the mouth. Very cold ice can freeze to the lips or tongue and cause injury.
- Never touch frozen goods with wet hands. Hands can freeze to the goods.
- Do not operate any electrical appliances in the refrigerator/freezer (e.g. electric ice cream makers, mixers etc.).
- Before cleaning the appliance switch off and remove the plug from the mains, or switch off or turn out the circuit breaker or fuse.
- Placing frozen goods on the top of the appliance can lead to the accumulation of condensate in the cavity of the storage tray through contact with the cold. Electronic components are housed within this cavity. If condensate should drip onto these components, the appliance could be damaged by a short circuit. For this reason do not place frozen goods on top of the appliance.
- When unplugging always pull the plug from the mains socket, do not pull on the cable.

In case of malfunction

- If a malfunction should occur at the appliance, refer first to the section "What to do if ..." in these operating instruction. If the instructions in this section are not sufficient, do not undertake any further work on your own.
- Refrigerators/freezers may only be repaired by trained personnel. Repairs carried out by untrained personnel can lead to substantial danger. Please contact your dealer or our customer service department for repairs.

Disposal

Appliance Packaging Information

All materials are environmentally sound! They can be dumped or burned at an incinerating plant without danger!

About the materials: The plastics can be recycled and are identified as follows:

>PE< for polyethylene, e.g. the outer covering and the bags in the interior.

>PS< for polystyrene foam, e.g. the pads, which are all free of chloro-fluorocarbon.

The carton parts are made from recycled paper and should be disposed of at a waste-paper recycling collection location.

Disposal of old Appliances

For environmental reasons, refrigeration appliances must be disposed of properly. This applies to your old appliance, and - at the end of its service life - for your new appliance as well.



Warning! Before disposing of old appliances make them inoperable. Remove plug from mains, sever the power cable, remove or destroy any snap or latch closures. This eliminates the danger that playing children lock themselves into the appliance (danger of suffocation!) or place themselves into other life-endangering situations.

Disposal:

- The appliance may not be disposed of with domestic waste or bulky refuse.
- The refrigerant circuit, especially the heat exchanger at the back of the appliance, may not be damaged.
- Information concerning collection schedules or locations can be obtained from the local disposal authorities or town hall.

Appliance Transport

Two persons are required for transport of the appliance. There are two recessed handles at the front of the base and at the back of the appliance at the top for improved gripping.



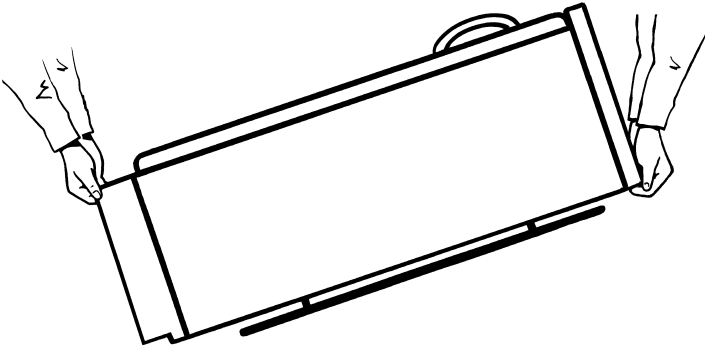

- ☞ Only for appliances with base cover: Pull cover up to remove.
- ☞ Grip the appliance with the recessed handles positioned as in the drawing, and transport the appliance.



- ☞ In order to push the appliance into its final position, press carefully at the top of the door and tip the appliance back slightly. The weight is thus transferred to the back casters and the appliance can be easily pushed.

Remove transport safeguard

The appliance as well as interior accessory parts are safeguarded for transport.

-  Remove tape from left and right of the outside of the door.
-  Tape remnants can be removed with benzene. Wipe off benzene.
-  Remove all tape and pads from the interior of the appliance.
-  Peel off the protective film from the control panel
-  Remove door seal safeguards from door seal at the inside of the door.

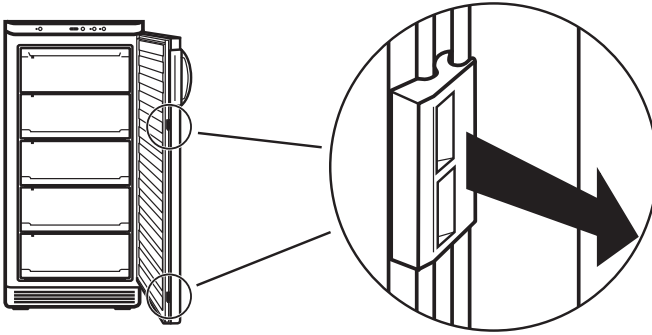

-  With open door remove transport safeguard at door pivot.

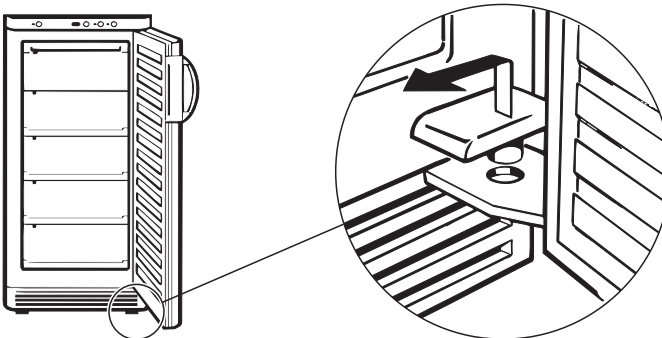

Installation

Installation Location

The appliance should be set up in a well ventilated, dry room. The basement is an ideal set-up location for freezers.

Energy use is affected by the ambient temperature.

The appliance should therefore

- not be exposed to direct sunlight;
- not be installed next to radiators, cookers or other sources of heat;
- only be installed at a location whose ambient temperature corresponds to the climate classification, for which the appliance is designed.

The climate classification can be found on the serial plate, which is located at the left on the inside of the appliance.

The following table shows which ambient temperature is correct for each climate classification:

Climate classification	for an ambient temperature of
SN	+10 to +32 °C
N	+16 to +32 °C
ST	+18 to +38 °C
T	+18 to +43 °C

If the refrigeration appliance is installed next to another refrigerator or freezer a clearance of 5 cm at the sides is required, in order to prevent the formation of condensation on the outside of the appliance.

The refrigerator or freezer needs air

Air is fed under the door through the vent slots in the base and is exhausted upwards along the back wall. To ensure proper air circulation never cover or alter the vent openings.

Attention! If the appliance is installed under, for example, a hanging cabinet, a clearance of at least 10 cm between the top of the appliance and the cabinet above it must be maintained.

- ✎ Insert both wall spacers (packed with the door handle) into the sockets in the back of the appliance as shown in the diagram, so that the required clearance for air exhaust at the back of the appliance is maintained.

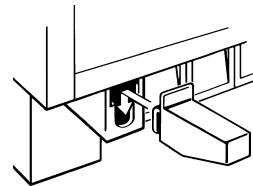
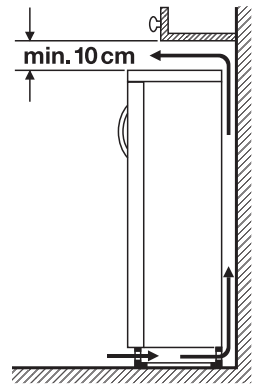

Appliance Alignment

- ✎ The appliance must have a solid, level footing. Please compensate for unevenness in the floor by turning the two adjustable feet at the front in or out.

Electrical connection



WARNING – THIS APPLIANCE MUST BE EARTHED

Please ensure that the voltage and current indicated on the rating plate agree with the voltage of your electricity supply. 220/240 volts (i. e. 220/240V AC).

If your appliance has been equipped with a mains lead with a moulded on type plug, you must comply with the following regulations: The plug moulded on to the cord incorporates a fuse. For replacement, use a 13 amp BS 1362 fuse. Only ASTA approved or certified fuses should be used. The fuse cover/carrier must be replaced in the event of changing the fuse. The plug must not be used if the fuse cover/carrier is lost. A replacement cover/carrier must be obtained from an electrical goods retailer. If the socket outlets in your home are not suitable for the plug fitted to the appliance, then the plug must be cut off and an appropriate one fitted. When fitting the plug please note the following points:

Important

The wires in the mains lead are coloured in accordance with the following code:

Green and Yellow	Earth
Blue	Neutral
Brown	Live

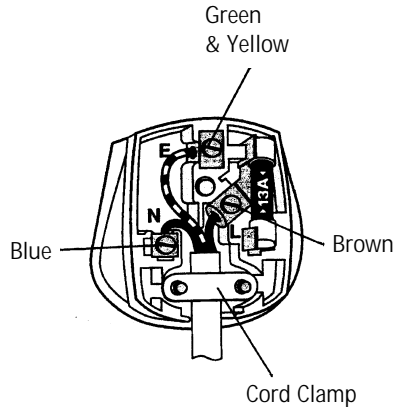

As the colours of the wires in the mains lead of this appliance may not correspond with the coloured markings identifying the terminals in your plug, proceed as follows:

1. The wire which is coloured green and yellow must be connected to the earth terminal in your plug, which is marked with the letter E or by the earth symbol \oplus or coloured green, or green and yellow.

2. The wire which is coloured brown must be connected to the live terminal which is marked with the letter L or coloured red.
3. The wire which is coloured blue must be connected to the neutral terminal which is marked with the letter N or coloured black.

When wiring the plug, ensure that all strand of wire are securely retained in each terminal.

Do not forget to tighten the mains lead clamp on the plug.



Warning! A cut-off plug inserted into a 13 amp socket is a serious safety (shock) hazard. Ensure that the cut-off plug is disposed of safely.

Voltage 220/240V AC

Fuse rating 13 amps

See rating plate for further information. The rating plate is inside, on the left.

Opening the door

If the door is closed when the appliance is in operation, it cannot be immediately opened again, because a vacuum occurs which holds the door closed until pressure has been equalised. The door can be opened again after several minutes.

If your appliance is equipped with a QUICK door opener - an opening mechanism integrated into the door handle - the door can be opened easily at any time.

Be sure that both catches (A) grip into the folds of the door seal as shown in the drawing.

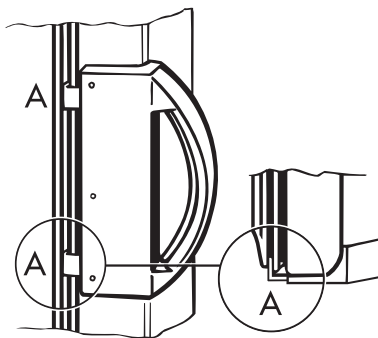

Re-Hanging Door

The side at which the door opens can be changed from the right side (factory adjustment) to the left side, if the installation site requires.

 **Warning!** When changing the side at which the door opens, the appliance may not be connected to the mains. Remove plug from the mains beforehand.

1. Appliances with base cover

 Pull base cover forward to remove and reposition the door pivot cover from the left to the right.

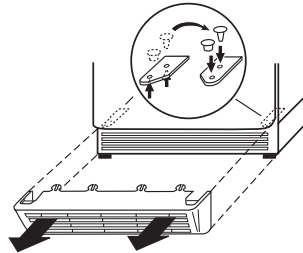

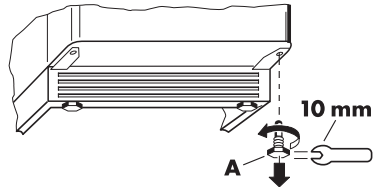

 With door closed screw pivot pin (A) out of the lower door pivot.



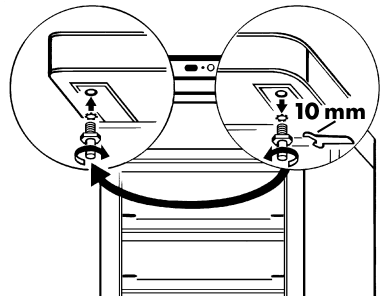

 Remove door carefully to the front and set aside.

 Reposition upper pivot pin to the left side.



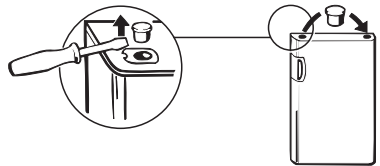

 Pry out cap at upper left of the door with a small screwdriver and reposition it to the right side.



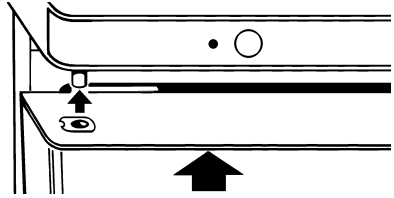

 Carefully set door into upper pivot and close.

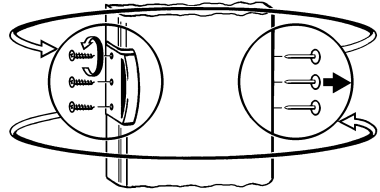

 Place washer between door and door pivot at bottom left, and turn pivot pin (A) into lower door pivot at the left.

 Reposition door handle and hole plug-pins as shown in the diagram.



 Replace base cover.

2. Appliances without base cover

 Lay the left side of the appliance onto a soft pad, e.g. rug, blanket etc.

 Turn pivot pin (A) out of lower door pivot.

 Remove door carefully and set aside.

 Turn the 4 phillips head screws (B) out of the base and remove the base.

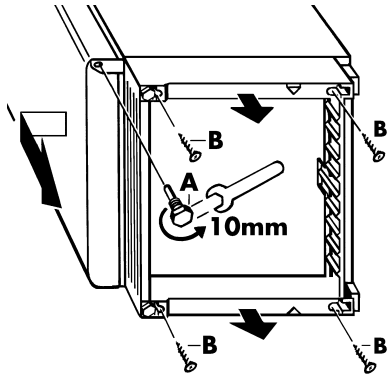

 Reposition door pivot (C) as well as base dummy-pivot (D) as shown in the diagram.

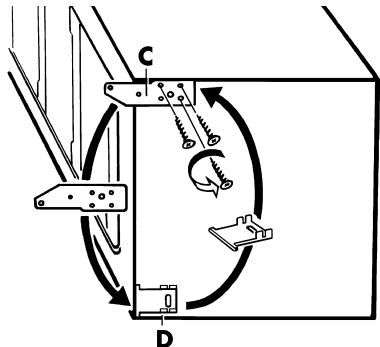

Re-Hanging Door

☞ Screw base back into place and then stand the appliance up.

☞ Reposition upper pivot pin to the left side.

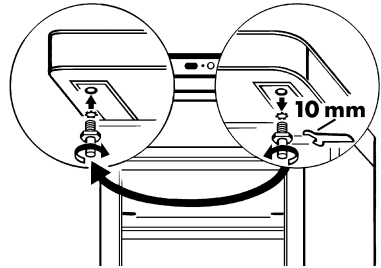

☞ Pry out cap at upper left of the door with a small screwdriver and reposition it to the right side.

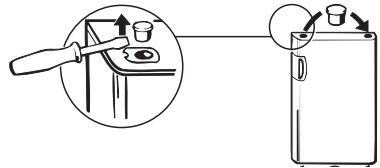

☞ Carefully set door into upper pivot pin and close.

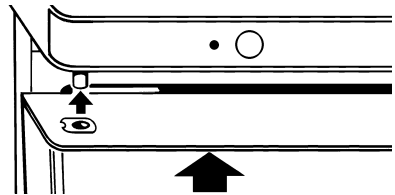

☞ Place washer between door and door pivot at bottom left, and turn pivot pin (A) into lower door pivot at the left.

☞ Reposition door handle and hole plug-pins as shown in the diagram.

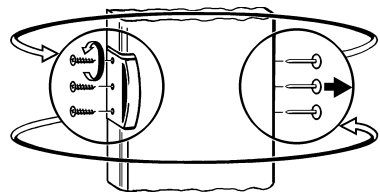

Door Alignment

If necessary, the appliance door can be aligned.

- ✎ First remove the door (see section: "Re-Hanging Door").
- ✎ Pry out the eccentric pivot bushings at the top and/or at the bottom of the door as needed with a small screw driver, turn as shown in the diagram and press back into place.

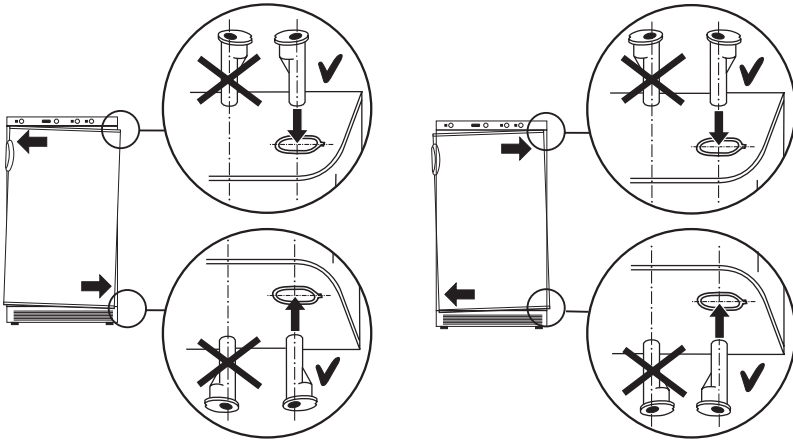

The diagram only shows a right opening door.
For left opening doors please proceed accordingly at the left of the door at top and/or bottom.

- ✎ Replace the door (see section: "Re-Hanging Door")

Appliance Description

View of Appliance

(various models)

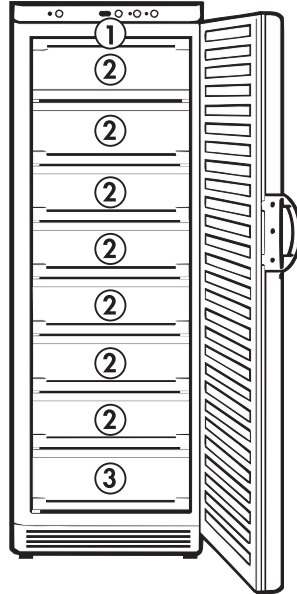
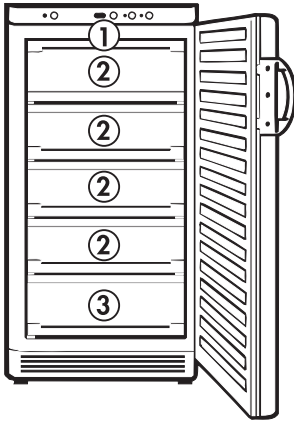

- ① Freezer tray
- ② Refrigerator compartments with lid(s) and drawers (for storage and freezing)
- ③ Drawer (for storage only)
When defrosting, the bottom drawer serves as a water collecting vessel.

Interior Illumination

(not included with all models)

The illumination switches on automatically when the appliance door is opened. By closing the appliance door it is automatically switched off.

- i** If the appliance door remains open for more than 5 minutes, the interior illumination starts to blink and then switches off automatically in order to save energy.

If directly after opening the door the interior illumination is not glowing although the appliance is in operation (recognisable through the green mains control indicator), the lamp is defective. Exchanging procedure is described in the chapter "Replace light bulb".

Freezer tray

A freezer tray is inserted at the very top of the freezer compartment at the back behind the freezer compartment flap.

- i** Berries, for example, can be pre-frozen on the freezer tray. Advantage: The berries are not squeezed and maintain their natural form. The frozen berries can then be stored in compartments or drawers packaged in individual portions.

Ice Packs

(not included with all models)

For some models two ice packs have been inserted into the freezer tray. Refer to the section "Prior to Initial Start-Up" concerning freezing of the ice packs.

- i** In the event of power failure or a malfunction at the appliance, the ice packs extend the period of time after which unacceptable warming of frozen goods occurs by several hours.
Ice packs may also be used, in passing, in cold storage bags.

Control Panel

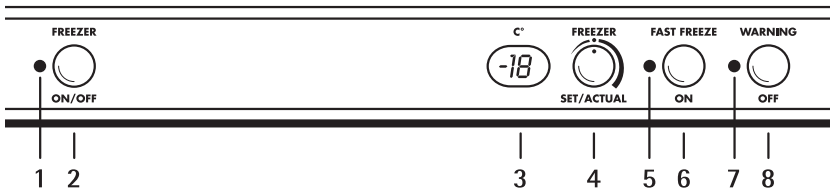

- 1 Stand-by display (green)
- 2 ON/OFF button
- 3 Temperature Display
- 4 Temperature regulator
- 5 Stand-by display for FAST FREEZE function (yellow)
- 6 FAST FREEZE button for fast freezing
- 7 Warning Display (red)
- 8 WARNING OFF button
(see section: "Control and Information Systems")

Temperature Regulator



For temperature adjustment the temperature regulator must be freed from its recessed position.

- Briefly pressing on the temperature regulator frees it from its recessed position.
- Pressing on the temperature regulator returns it to its recessed position.

SET means:

With temperature regulator freed from recessed position; temperature which should exist in the freezer compartment (SET temperature), can be adjusted in increments of 1°C.

ACTUAL means:

With temperature regulator in recessed position; temperature display indicates current actual freezer compartment temperature (ACTUAL temperature).

Temperature Display

°C The temperature display shows several types of information.



- In normal operation the current freezer compartment temperature is displayed (actual temperature). The temperature regulator must be in its recessed position.
- During temperature adjustment, a blinking display of the temperature selected at the moment occurs (SET temperature). The temperature regulator must be freed from its recessed position.
- During a mains power interruption a blinking display of the current freezer compartment temperature occurs (actual temperature). (not included with all models)
- If, for example, the frozen goods were partially or completely thawed temporarily due to a lengthy power interruption, the temperature display alternately indicates:
 - the current freezer compartment temperature (actual temperature) and
 - the highest temperature to which the frozen goods have warmed.
- If a malfunction has occurred at the appliance the temperature display alternately indicates:
 - the current freezer compartment temperature (actual temperature) and
 - an error message.

The error message is coded (e.g. F1, F2, etc.) and assists the customer service technician in error diagnosis. If the temperature can no longer be registered, only the error code is displayed.





FAST FREEZE Button







By pressing the FAST FREEZE button the FAST FREEZE function is switched on. It speeds up freezing of fresh foods and, at the same time, protects already refrigerated goods against undesired warming.

The appliance electronics automatically recognise when the FAST FREEZE function can be stopped, and switch it off automatically (after 30 to a maximum of 51 hours depending on amount to be frozen). The FAST FREEZE function can also be stopped manually at any time by pressing the FAST FREEZE button again.

Prior to Initial Start-Up

-  Please clean the appliance interior and all accessories prior to initial start-up (see section: "Cleaning and Care").
-  Remove both ice packs from the freezer tray, if they are included with your model.
-  Place the ice packs into a compartment or drawer only after the optimal storage temperature of -18°C has been reached, and allow to freeze.
-  After 24 hours place the ice packs at the front of the freezer tray.
-  Re-freeze thawed ice packs in the same fashion, e.g. after cleaning the appliance.

Initial Start-Up

-  Insert plug into mains socket.
-  Press ON/OFF button. The green stand-by display lights up. The temperature display shows the current freezer compartment temperature (actual temperature). The blinking red warning display indicates that the required storage temperature has not yet been reached.
Note: Within 5 minutes after the appliance has been switched on, the electronics initialise a self-test. The compressor does not start until after completion of the self-test.
-  Set temperature to -18°C or colder (see section: "Temperature Adjustment").
Note: The factory setting for the temperature of the freezer compartment is -15°C .
-  Do not load freezer with goods until the temperature has reached -18°C , or until the red warning display has gone out.

Temperature Adjustment

- ☞ Press temperature regulator and free it from its recessed position. The temperature display is switched to a blinking display of the currently selected SET temperature.
- ☞ Turn temperature regulator to left or right to select the desired SET temperature. The temperature display immediately indicates the newly selected adjustment:



Initial setting
(-18°C)



warmer
(to -15°C)



colder
(to -24°C)

Note: From a food sciences standpoint -18°C is considered to be a sufficiently cold storage temperature.

- ☞ Push temperature regulator into its recessed position. The temperature display is switched back to indication of the current actual freezer compartment temperature.

Important! Please check red warning display and temperature display regularly to assure maintenance of the storage temperature.

Switching the Appliance Off





In order to protect frozen goods, the appliance is guarded against accidental switching off (child-proof).

-  To switch off press and hold the ON/OFF button for about 5 seconds. A so-called "count down" is started in the temperature display, which counts backwards from "5" to "0". When "0" is reached the appliance switches off. Illumination at the temperature display goes off.

Note (applies only to models with mains failure warning):

If you remove the plug or disconnect the circuit fuse without previously switching off the appliance with the ON/OFF button, an audible warning signal makes you aware of the power interruption. The warning signal can be temporarily silenced with the WARNING/OFF button, but it nevertheless sounds again after 2 hours. In this case, connect the appliance to the mains again and press and hold the ON/OFF button for about 5 seconds.

If the appliance is to be removed from service for a lengthy period:

-  Switch appliance off by pressing and holding the ON/OFF button for about 5 seconds.
-  Remove the mains plug or switch off or turn out the circuit breaker or fuse.
-  Defrost freezer compartment and clean thoroughly (see section: "Cleaning and Care").
-  Leave door open after defrosting to avoid accumulation of odours.

Control and Information Systems

The control and information systems consist of a temperature display, an optical warning display and an acoustic warning device.

The system warns of:

- open appliance door (not included with all models);
- power interruption (not included with all models);
- excessive temperature in the freezer compartment;
- possible partial or complete thawing of frozen goods;
- functional disturbances at the appliance.

"Open Door"-Warning (not included with all models!)

When the door is open the red warning display blinks. If the door remains open for more than 80 seconds, an audible warning also sounds. If you need more time for loading or rearranging frozen goods, you can switch off the audible warning by pressing the WARNING OFF button.

Power Interruption (not included with all models!)

If the power supply is interrupted, an audible warning sounds at 20 second intervals. In addition, the current actual temperature in the freezer compartment is indicated in blinking fashion by the temperature display (2 seconds on, 2 seconds off). After one hour the audible warning only sounds at 40 second intervals.

The audible warning can be switched off for about 2 hours with the WARNING OFF button.

In the event of a power interruption, the control and information systems can maintain operation of the temperature display and warning signal for up to 12 hours.

Temperature Warning

The red warning display blinks and an audible warning sounds, as soon as the temperature in the freezer compartment climbs to more than 5°C above the selected SET temperature. A rise in temperature of more than 5°C may be caused by:

- frequent door opening for long periods of time;
- loading with large quantities of warm foods;
- an error at the appliance.

The audible warning can be switched off with the WARNING OFF button.

Both warning display and audible warning are automatically switched off when the actual temperature in the freezer compartment falls to 4°C warmer than the selected SET temperature.

Note:

- The red warning display and the audible warning are inoperable: after temperature adjustment, until the selected SET temperature has been reached (exception: actual temperature exceeds -10°C).
- Only the audible warning is inoperable:
 - after the appliance is switched on, and until the selected SET temperature has been reached for the first time;
 - when the FAST FREEZE button is depressed.

Partial/Complete Thaw Warning

If frozen goods have been partially or completely thawed (e.g. during a temporary power interruption), the red warning display blinks.

In addition the temperature display alternately indicates:

- the highest temperature to which the frozen goods have warmed;
- and the current actual temperature in the freezer compartment.

If suspicion of partial or complete thawing exists, please check the quality of the foods to determine if they can be used.

As soon as the temperature in the freezer compartment has again fallen below the critical thawing temperature of -4°C, the partial/complete thaw warning can be switched off with the WARNING OFF button.

Note: After the appliance has been switched on, the partial/complete thaw warning remains inoperative until the selected SET temperature has been reached for the first time.

Function Errors

If the appliance electronics have detected a technical malfunction which has to be corrected by a customer service technician, both optical and acoustic warnings are activated. In addition the temperature display alternately indicates:

- an error message (error code F1, F2, etc.) and
- the current freezer compartment temperature (actual temperature).

Note: An appliance malfunction which is indicated by an error code, must be corrected by a customer service technician. The acoustic

warning can be switched off for 24 hours with the WARNING OFF button. Cancelling of the error display is possible by switching the appliance off, which should however only be undertaken during repair by the customer service technician.

Freezing

Except for the bottom drawer, which serves for storage purposes, all compartments and drawers are suited for freezing.

Attention!

- Before foods are frozen, the actual temperature in the freezer compartment must be -18°C or colder.
- Please observe indicated freezing capacity on the serial plate. The freezing capacity represents the maximum amount of fresh goods that can be frozen within 24 hours. If you freeze goods on several days, one after the other, freeze amounts equal to 2/3 to 3/4 of the capacity indicated on the serial plate.
- Thawed foods which have not been processed further (cooked into meals) may not under any circumstances be frozen a second time.

 For exploitation of maximum freezing capacity press the FAST FREEZE button 24 hours prior to freezing, or 4 to 6 hours for smaller quantities. Yellow display lights up.

 The FAST FREEZE button need not be pressed for freezing of small quantities of up to 3 kg.

 All foods must be packed air tight prior to freezing, so that they do not dry out or lose their flavour, and so that no flavour contamination of other frozen goods occurs.

Caution! Do not touch frozen goods with wet hands. Hands can freeze to the goods.

 Place packaged foods in the compartments or drawers. Unfrozen goods may not come into contact with already frozen goods, otherwise the frozen goods may start to thaw.

 The appliance electronics recognise automatically when the FAST FREEZE function can be ended, and switch it off automatically. Yellow display goes out. You can also stop the FAST FREEZE function manually by pressing the FAST FREEZE button again.

Tips:

- The following are suited for the packaging of frozen goods:
 - freezer bags and polyethylene wraps;
 - special cans for frozen goods;
 - extra-thick aluminium foil
- The following are suited for sealing bags and wraps:
plastic clips, rubber bands or adhesive tape.
- Press air out of bags and wraps before sealing, because air encourages drying of frozen goods.
- Make flat packages, because these freeze more quickly.
- Do not fill cans for frozen goods to the brim with liquid or paste-like goods, because liquids expand during freezing.

Note for inspection authorities:

Batch plans for the determination of freezing performance or warm-up time can be requested directly from the manufacturer.

Frozen Storage



Attention! Before initial loading of the freezer compartment with previously frozen goods, the required storage temperature of -18°C must be reached.

- Load freezer only with packaged frozen goods, so that they do not dry out or lose their flavour, and so that no flavour contamination of other frozen goods can occur.
- Please observe maximum storage times and expiry dates of frozen goods.



In so far as possible store frozen goods separately according to type in compartments and drawers. Some models are provided with index-tabs which can be attached to compartment doors and drawers. In order to identify the contents of individual compartments, attach the index-tabs so that they cover the storage goods symbols (see section: "Storage Goods Symbols/Freezing Calendar"). Thus you have a better overview, avoid opening the door for long periods and therefore save energy.

Preparation of Ice Cubes

-  Fill ice cube tray (not included with all models) 3/4 full with cold water and place in the freezer tray or a drawer and allow to freeze.
-  To remove the finished ice cubes twist the ice cube tray or hold under running water for a short time.

Attention! Do not, under any circumstances, free an ice tray which is frozen to the appliance with pointed or sharp edged objects. Use a spoon-handle or similar object.

Storage Goods Symbols/Freezing Calendar

(not included with all models)

- The symbols on the compartment flaps and drawers show different types of frozen goods.



- The numbers indicate storage times in months for the appropriate types of frozen goods. Whether the upper or lower value of the indicated storage time is valid depends on the quality of the foods and pre-treating before freezing. The lower value applies to foods with high fat content.

- By attaching the included index-tabs to the compartment flaps and drawers, they can be marked according to which type of foods the individual compartments contain.

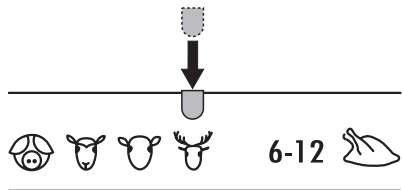

Maximum Load/Stacking Limit

In order to load large quantities or bulky freezer items, you can remove the drawers (except for the bottom one) and place the freezer goods directly onto the evaporator grid.

However, when the drawers are removed, the freezer goods may not extend above the marking on the left side of the appliance interior.

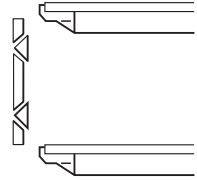

Defrosting

Moisture is precipitated in the form of white frost during operation and when the door is open, especially on the evaporators. Remove this white frost from time to time with a soft plastic scraper, e.g. a dough scraper. Do not under any circumstances use hard or pointed objects for this purpose.

The appliance should be defrosted when the thickness of the white frost has reached about 4 mm; but at least once a year in any case. A convenient time for defrosting is any time when the appliance is empty, or only minimally loaded.



Warning!

- Do not use electrical heating appliances or any other mechanical or artificial devices to speed up the defrosting process, with the exception of those recommended in these operating instructions.
- Do not use defrosting sprays, because they may be health endangering and/or contain substances damaging to plastics.



If large quantities of frozen goods are in storage, press the FAST FREEZE button about 12 hours prior to defrosting, so that the frozen goods can build up a sufficient chill reserve.

Caution! Do not touch frozen goods with wet hands. Hands can freeze to the goods.



Remove frozen goods, pack them in several layers of newspaper, cover them and store them in a cool place, e.g. in a refrigerator.



Switch appliance off and remove plug from the mains, or switch off or turn out the circuit breaker or fuse.

 Remove all drawers except for the one at the bottom. The bottom drawer serves as a practical water collecting vessel.

Tip: In order to speed up the defrosting process, place a pot of hot water in the appliance and close the door. Remove pieces of ice that break away before defrosting is complete.

 After defrosting thoroughly clean the freezer interior, as well as interior accessories (see section: "Cleaning and Care").

Cleaning and Care

For hygienic reasons the appliance interior, including interior accessories, should be cleaned regularly.



Warning!

- The appliance may not be connected to the mains during cleaning. Danger of electrical shock! Before cleaning switch the appliance off and remove the plug from the mains, or switch off or turn out the circuit breaker or fuse.
- Never clean the appliance with a steam cleaner. Moisture could accumulate in electrical components, danger of electrical shock! Hot vapours can lead to the damage of plastic parts.
- The appliance must be dry before it is placed back into service.

Attention!

- Ethereal oils and organic solvents can attack plastic parts, e.g.
 - lemon juice or the juice from orange peels;
 - butyric acid;
 - cleansers which contain acetic acid.Do not allow such substances to come into contact with appliance parts.
- Do not use any abrasive cleansers.

 Defrost the freezer compartment (see section: "Defrosting").

 Clean the appliance and the interior accessories with a cloth and luke-warm water. Commercially available dish washing detergents may also be used.

 After cleaning wipe with fresh water and rub dry.



Accumulation of dust at the condenser increases energy consumption. For this reason carefully clean the condenser at the back of the appliance once a year with a soft brush or a vacuum cleaner.



After everything is dry place appliance back into service.



Energy Saving Tips

- Do not install the appliance near cookers, radiators or other sources of warmth. High ambient temperatures cause longer, more frequent operation of the compressor.
- Ensure sufficient air circulation and exhaust at the appliance base and at the back wall of the appliance. Never cover air vent openings.
- Do not place warm foods into the appliance. Allow warm foods to cool first.
- Only leave door open as long as necessary.
- Do not set temperature any colder than necessary.
- Place frozen goods into the refrigerator for thawing. Cold from frozen goods is thus used for cooling in the refrigerator.
- Always keep the condenser at the back of the appliance clean.

What to do if ...

Correcting Malfunctions

Perhaps a malfunction has been caused by a minor error, which you can correct yourself with the help of the following instructions. Do not attempt any further repairs if the following instructions do not help in each specific case.



Warning! Refrigerators/freezers may only be repaired by trained personnel. Repairs carried out by untrained personnel can lead to substantial danger for the user. Please contact your dealer or our customer service department for repairs.

Malfunction	Possible cause	Remedy
Appliance does not function, green stand-by display and temperature display are not lit.	Appliance is not switched on.	Switch appliance on.
	Mains plug is not inserted or is loose.	Insert mains plug.
	Fuse has blown or is defective.	Check fuse, replace if necessary.
	Mains socket is defective.	Mains malfunctions are to be corrected by an electrician.
Appliance does not function, green stand-by display is not lit, temperature is indicated as blinking display, audible warning sounds at regular intervals. ¹	Mains interruption warning. ¹	Please check to see if the mains plug is inserted or if the fuse has blown (see also section: "Control and Information Systems").
Red warning display blinks, two temperatures are indicated alternately by the temperature display.	Partial/Complete Thaw Warning. Frozen goods have been warmed to such an extent that they have been partially or completely thawed.	Please refer to the section "Control and Information Systems".

Malfunction	Possible cause	Remedy
Red warning display blinks, audible warning sounds, temperature display indicates an error (F1, F2, etc.).	A functions error has occurred.	Switch the audible warning off by pressing the WARNING OFF button. Please make a note of the indicated error and inform the customer service department. Do not open the appliance door again.
The freezer compartment temperature is insufficient.	Temperature is not properly adjusted.	Please refer to the section "Temperature Adjustment".
	Door was open for a long time.	Only leave the door open as long as necessary.
	Within the last 24 hours a large quantity of warm foods were loaded.	Press FAST FREEZE button.
	Appliance is next to a source of warmth.	Please refer to the section "Installation Location".
Interior illumination does not function. ¹	Light bulb is defective. ²	Please refer to "Interior Illumination" in this section.
If the door remains open for more than 5 minutes, the interior illumination blinks and is switched off after ²	This is normal, no error has occurred.	Please refer to "Interior Illumination" in this section.
Interior illumination is not switched off when door is closed. ²	Door contactor is not properly aligned. ²	Please refer to "Adjust door contactor" in this section.
Audible warning "Door Open" sounds, although the door is closed. ¹	Door contactor is not properly aligned. ¹	Please refer to "Adjust door contactor" in this section.

1) not included with all models

2) only for models with interior illumination

Malfunction	Possible cause	Remedy
Large accumulation of frost in the appliance, perhaps also at the door seal.	Door is not properly sealed (perhaps after re-hanging door).	Carefully warm the door seal with a hand-held hair dryer at those points which are not airtight (no warmer than approx. 50°C). At the same time, shape the warmed door seal by hand, so that it is again properly seated.
Unusual noises.	Appliance is not level.	Readjust the front levelling feet.
	Appliance is in contact with wall or other objects.	Push appliance away a short distance.
	A part at the back of the appliance, e.g. a tube, is in contact with another appliance part or the wall.	Bend this part away carefully if necessary.
The compressor does not start immediately after pressing the FREEZE button, or after changing the temperature setting.	This is normal, no error has occurred.	The compressor starts after a period of time.
Compressor does not start after appliance is switched on.	Within the first 5 minutes after switching the appliance on, the electronics initialise a self-test.	The compressor is started automatically, after the self-test has been completed.

Interior Illumination

(not included with all models)



-  If the appliance door remains open for more than 5 minutes, the interior illumination starts to blink and then switches off automatically in order to save energy.
If the interior illumination does not light when the door is open, although the temperature display is lit, the bulb is defective (see section: "Replace light bulb").

Replace light bulb

(only for models with interior illumination)

-  **Warning!** Danger of electrical shock! Before replacing the light bulb switch appliance off and remove the mains plug, or switch off or turn out the circuit breaker or fuse.

Light bulb specifications: 220-240 V, max. 15 W, socket: E 14

-  To switch the appliance off press and hold both ON/OFF buttons for about 5 seconds.
-  Remove mains plug.
-  Replace defective light bulb. The light bulb is accessible from the back side of the lamp cover.

Adjust door contacter

(only for models with interior illumination)

If, for example, the illumination is not automatically switched off when the door is closed, or if the "Open Door" warning signal sounds, the contacter at the top of the door may need to be readjusted.

- ☞ Loosen phillips head screw and push contactor towards the inner side of the door.
- ☞ Re-tighten phillips head screw.
- ☞ Please check,
 - if illumination is switched off when the door is closed and
 - if the audible warning signal sounds after the door has been open for about 80 seconds.
 If not, readjust contactor again.

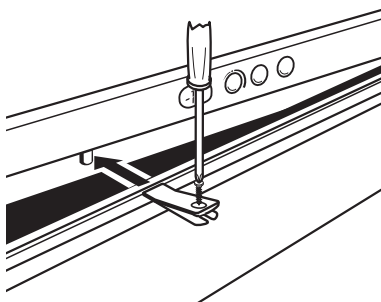

Customer Service

If you cannot find the remedy for a malfunction in these operating instructions, please contact your dealer or our customer service department. Addresses and telephone numbers are listed in the accompanying booklet "Guarantee Conditions/Customer Service Locations". Selective ordering of replacement parts can save unnecessary travel and costs. For this reason always provide the following appliance information:

This information can be found on the serial plate in the interior at the

- Model Name
- Model Number (PNC)
- Serial Number (S-No.)

left of the appliance. We recommend that you enter this information here, so that it is handy if needed.

If the temperature display should indicate an error (F1, F2, etc.), inform customer service of the displayed error.

Note: The customer bears the costs of unjustified customer service calls even during the guarantee period.

Noises during Operation

The following noises are characteristic of refrigeration appliances:

- **Clicks**

Whenever the compressor switches on or off, a click can be heard.

- **Humming**

As soon as the compressor is in operation, you can hear it humming.

- **Bubbling/Splashing**

When refrigerant flows into thin tubes, you can hear bubbling or splashing noises. Even after the compressor has been switched off, this noise can be heard for a short time.

Regulations, Standards, Guidelines

This appliance was designed for household use and was manufactured in accordance with the appropriate standards. The necessary measures in accordance with appliance safety legislation regulations (GSG), accident prevention regulations for refrigeration appliances (VBG 20) and the regulations of the German Society of Electrical Engineers (VDE) were observed in the manufacture of this appliance.

The refrigerant circuit has been checked for leaks.

- CE** This appliance is in accordance with the following EU guidelines:
- 73/23/EEG dated 19 February 1973 - low voltage guidelines.
 - 89/336/EEG dated 3 May 1989
(including guideline change notice 92/31/EEG) - EMV guideline

Technical Terminology

- **Refrigerant**

Fluids, which are used for refrigeration are called refrigerants. They have a relatively low boiling point; so low, that the warmth of foods in the refrigeration appliance can cause them to boil or vaporise.

- **Refrigerant circuit**

Sealed circulation system, in which the refrigerant is found. The refrigerant circuit consists for the most part of an evaporator, a compressor, a condenser and tubing.

- **Evaporator**

The refrigerant is evaporated in the evaporator. This warmth is withdrawn from the appliance interior, which is thus cooled. Like all fluids, refrigerants require warmth in order to be evaporated. For this reason the evaporator is located in the appliance interior.

- **Compressor**

The compressor looks like a small bin. It is powered by an electric motor and is housed at the back in the base of the appliance. It is the task of the compressor to withdraw vaporous refrigerant from the evaporator, to compress it and feed it to the condenser.

- **Condenser**

The condenser is usually in the form of a grid. Compressed refrigerant from the compressor is liquefied in the condenser. Thus warmth is released, which is given off into the surrounding air at the surface of the condenser. The condenser is therefore outside of the appliance, usually at the back.

AEG Hausgeräte GmbH
Postfach 1036
D-90327 Nürnberg

<http://www.aeg.hausgeraete.de>

© Copyright by AEG

H 271 282 400 – 04 - 0598