

12 H.P. 32" Lawn Tractor

Operating Manual

Model No. TMO-33919B

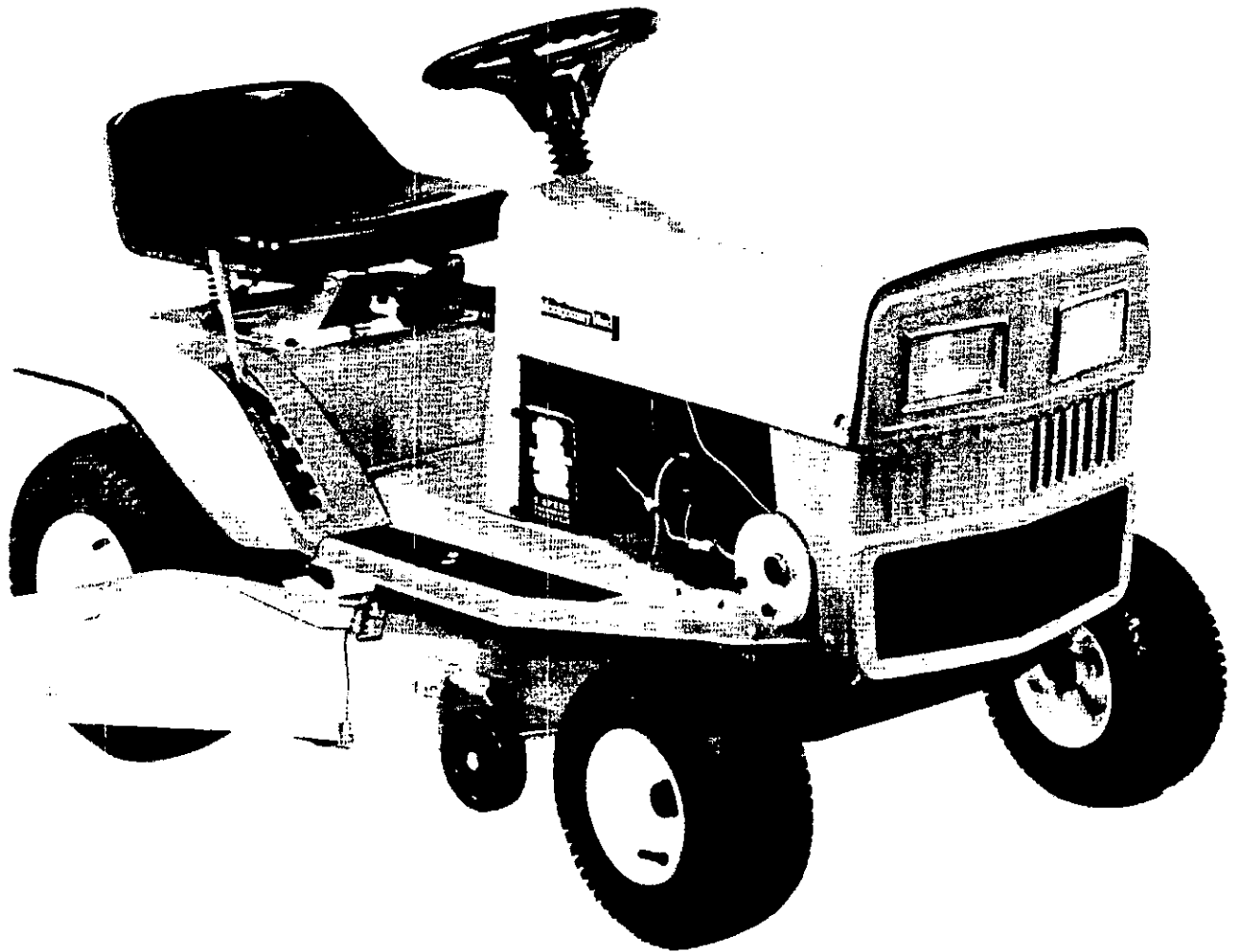

Montgomery Ward

INDEX

Slope Gauge	3
Contents of Hardware Pack	4
Rules for Safe Operation	5
Assembly Instructions	6
Controls	10
Operation	11
Adjustments	13
Lubrication	16
Maintenance	17
Off-Season Storage	20
Trouble Shooting Chart	21, 22
Illustrated Parts for Lawn Tractor	23-31
Electrical System	30
Illustrated Parts for Transaxle	32, 33
Parts Information	Back Cover

Dear Customer,

So often throughout the year we are all in a rush to meet our daily obligations.

However, we at Montgomery Ward are taking a quick moment out to say...

"Thank you for your business."

Sincerely,
MONTGOMERY WARD



INSTRUCTIONS GIVEN WITH THIS SYMBOL ARE FOR PERSONAL SAFETY. BE SURE TO FOLLOW THEM.

NOTICE: A data plate with the model number and serial numbers of your unit is located on the frame, under the seat. Record these numbers in the spaces provided on the back cover of this guide.

BEFORE YOU CALL SERVICE

Check Spark Plug Wire

- Firmly attached?
- Wire terminal clean?

Check Crankcase Oil Level

- Overfilled/underfilled?

Check Fuel Tank

- Fuel in tank?
- Fuel dirty or stale?
- If tank has been empty for a long period, fill tank completely.

Check Air Cleaner

- Clean?
- Choke plate stuck?
- Governor spring free to move?

Check Under Blade Housing (**Disconnect Spark Plug First**)

- Blade obstructed or bent?

Check Starting Instructions

- Read instruction manuals and labels for specific instructions.

WARNING: This unit is equipped with an internal combustion engine and should not be used on or near any unimproved forest-covered, brush-covered or grass-covered land unless the engine's exhaust system is equipped with a spark arrester meeting applicable local or state laws (if any). If a spark arrester is used, it should be maintained in effective working order by the operator.

In the State of California the above is required by law (Section 4442 of the California Public Resources Code). Other states may have similar laws. Federal laws apply on federal lands. A spark arrester for the muffler is available through your nearest engine authorized service center.

SLOPE GAUGE

(Keep this sheet in a safe place for future reference.)

--Cut Along This Line

USE THIS SHEET AS A GUIDE TO DETERMINE SLOPES WHERE YOU MAY NOT OPERATE SAFELY.

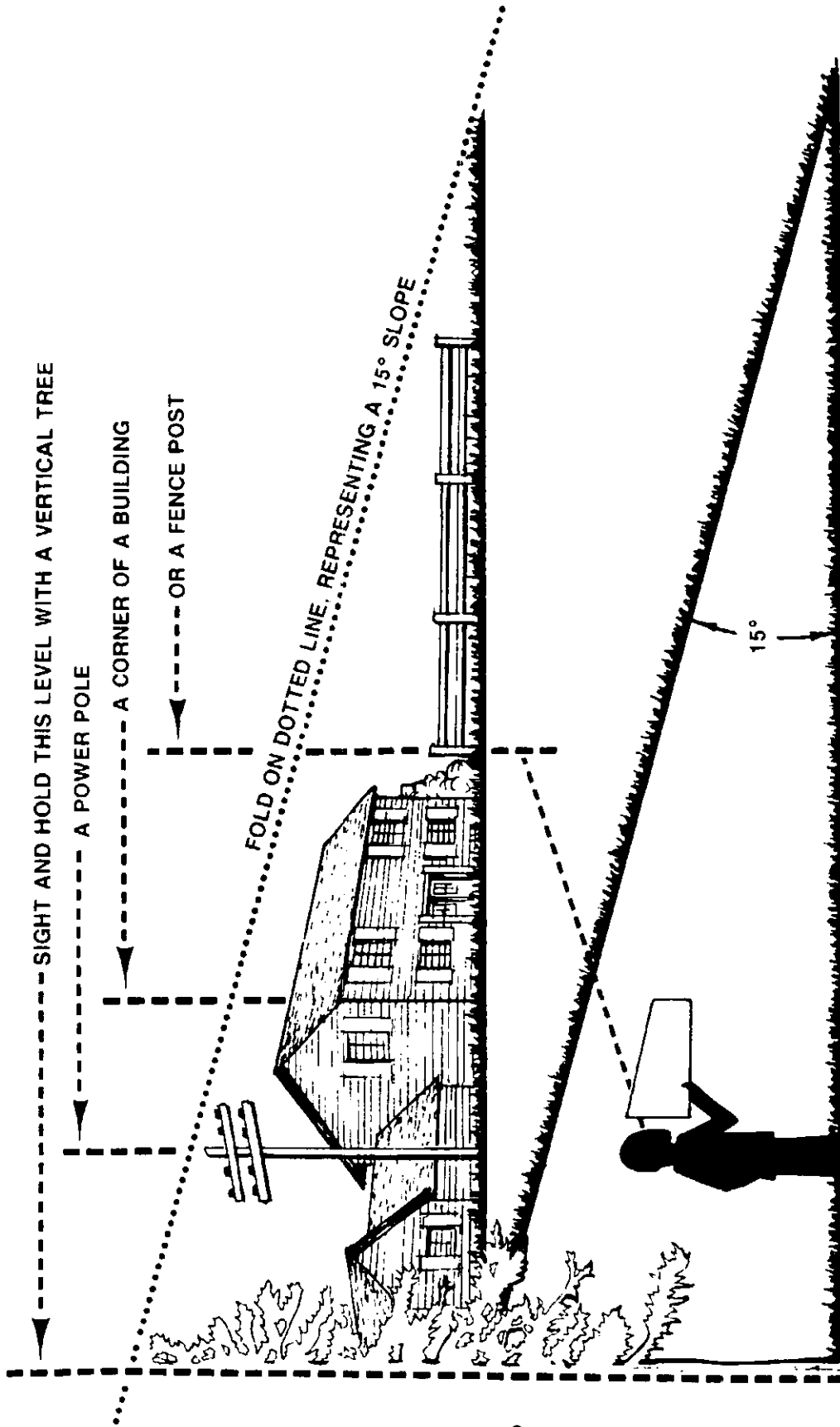

Do not mow on inclines with a slope in excess of 15 degrees (a rise of approximately 2½ feet every 10 feet). A riding mower could overturn and cause serious injury. If operating a walk-behind mower on such a slope, it is extremely difficult to maintain your footing and you could slip, resulting in serious injury.

Operate RIDING mowers up and down slopes, never across the face of slopes.

Operate WALK-BEHIND mowers across the face of slopes, never up and down slopes.

CONTENTS OF HARDWARE PACK

Remove this sheet from your owner's manual and lay the hardware on the illustration for identification purposes. After assembly, keep the Slope Gauge which is on the reverse side of this sheet for future use.

(Hardware pack may contain extra items which are not used on your unit.)

A INSTALLING THE BATTERY Cable Tie (Battery Box is Not Shown)

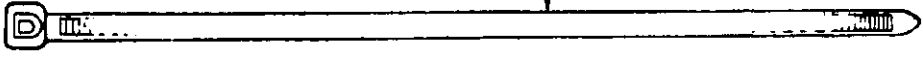

B ATTACHING THE STEERING MECHANISM Steering Bellow

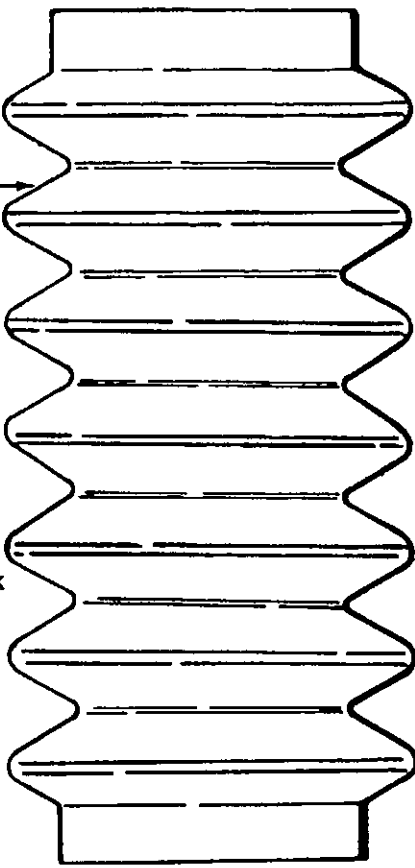

Flat Washer
5/8" I.D.
x 1 1/4" O.D.

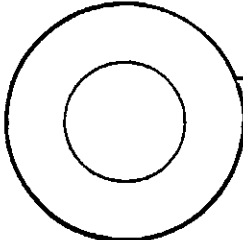

Steering Column Bearing

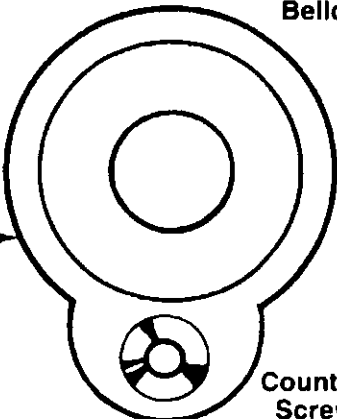

Hex Flange Bearing

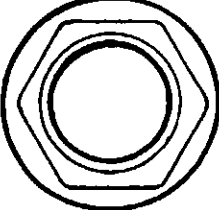

Countersunk Screw #10
x 5/8" Long



Hex Nut
5/16-24 Thread



Spacer

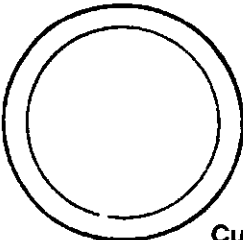

Cupped Washer
5/16" I.D. x
7/8" O.D.

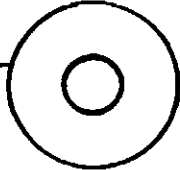

Flat Washer
5/16" I.D.
x 1-1/8" O.D.

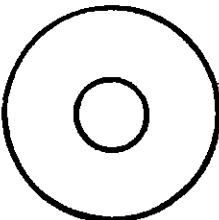

Steering Wheel Cap

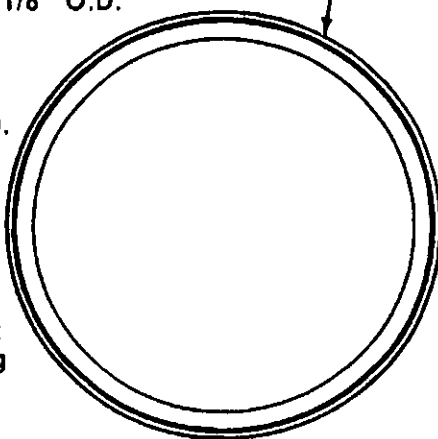

Lock Washer
5/16" I.D.



Hex Bolt
5/16-18 x
5/8" Long



C ATTACHING THE SEAT

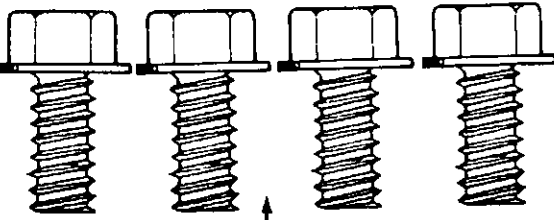

Self-Tapping Screws
3/8-16 x 3/4" Long

D IGNITION KEYS
(May Be Attached to Tractor)

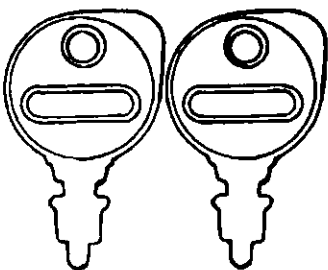

Cut Along This Line

4

IMPORTANT

RULES FOR SAFE OPERATION



THIS SYMBOL POINTS OUT IMPORTANT SAFETY INSTRUCTIONS WHICH, IF NOT FOLLOWED, COULD ENDANGER THE PERSONAL SAFETY AND/OR PROPERTY OF YOURSELF AND OTHERS. READ AND FOLLOW ALL INSTRUCTIONS IN THIS MANUAL BEFORE ATTEMPTING TO OPERATE YOUR UNIT. FAILURE TO COMPLY WITH THESE INSTRUCTIONS MAY RESULT IN PERSONAL INJURY. WHEN YOU SEE THIS SYMBOL—  **HEED ITS WARNING.**



DANGER

Your unit was built to be operated according to the rules for safe operation in this manual. As with any type of power equipment, carelessness or error on the part of the operator can result in serious injury. If you violate any of these rules, you may cause serious injury to yourself or others.

1. READ THIS OWNER'S MANUAL carefully in its entirety before attempting to assemble or operate this unit. Keep this manual in a safe place for future and regular reference and for ordering replacement parts.
2. This unit is a precision piece of power equipment, not a plaything. Therefore exercise extreme caution at all times.
3. Know the controls and how to stop the machine quickly.
4. Do not allow children to operate vehicle. Do not allow adults to operate it without proper instruction. Only persons well acquainted with these rules of safe operation should be allowed to use your mower.
5. Wear sturdy, rough-soled work shoes and close-fitting slacks and shirts to avoid entanglement in the moving parts. Never operate a unit in bare feet, sandals, or sneakers.
6. To prevent injury, do not carry passengers or give rides. Keep children, pets and bystanders out of the area while mowing. Only the operator should ride on the unit and only ride in the seat.
7. Check overhead clearance carefully before driving under power lines, guy wires, bridges or low hanging tree branches, before entering or leaving buildings, or in any other situation where the operator may be struck or pulled from the unit, which could result in serious injury.
8. To maintain control of the unit and reduce the possibility of upset or collision, operate the tractor smoothly. Avoid erratic operation and excessive speed.
9. Keep the area of operation clear of all persons, particularly small children and pets. Stop engine when they are in the vicinity of your mower. Although the area of operation should be completely cleared of foreign objects, a small object may have been overlooked and could be accidentally thrown by the mower in any direction and cause injury to you or a bystander.
10. Stop the blade(s) when crossing gravel drives, walks or roads.
11. Disengage all attachment clutches and shift into neutral before attempting to start engine.
12. Disengage power to attachment(s) and stop engine before leaving operating position.
13. Do not put hands or feet near or under rotating parts. Keep clear of the discharge opening at all times as the rotating blade(s) can cause injury.
14. Disengage power to attachment(s) and stop engine before making any repairs or adjustments. Disconnect the spark plug wire and keep the wire away from the plug to prevent accidental starting.
15. Before attempting to unclog the mower or discharge chute, stop the engine. The mower blade(s) may continue to rotate for a few seconds after the engine is shut off. Therefore be sure the blade(s) have stopped completely. Disconnect the spark plug wire and keep the wire away from the plug to prevent accidental starting.
16. Disengage power to attachment(s) when transporting or not in use.
17. Take all possible precautions when leaving vehicle unattended such as disengaging power take-off, lowering attachments, shifting into neutral, setting parking brake, stopping engine and removing key.
18. For your safety, use the slope gauge included as part of this manual to measure slopes before operating this unit on a sloped or hilly area. If the slope is greater than 15° as shown on the slope gauge, do not operate this unit on that area or serious injury could result.
19. Do not stop or start suddenly when going uphill or downhill. Mow up and down face of steep slopes; never across the face. Use extreme caution if it is necessary to drive the tractor up an incline or back the tractor down an incline because the front of the tractor could lift and rapidly flip over backward which could cause serious injury.
20. Reduce speed on slopes and in sharp turns to prevent tipping or loss of control. Always keep the tractor in gear when going down steep hills to take advantage of engine braking action.
21. Stay alert for holes in terrain and other hidden hazards which may cause the unit to tip over.
22. Use care when pulling loads or using heavy equipment.
 - A. Use only approved drawbar hitch points.
 - B. Limit loads to those you can safely control.
 - C. Do not turn sharply. Use care when backing.
 - D. Use counterweight(s) or wheel weights when suggested in owner's manual.
23. Watch out for traffic when crossing or near roadways.
24. When using any attachments, never direct discharge of material toward bystanders nor allow anyone near vehicle while in operation.
25. Handle gasoline with care. It is highly flammable.
 - A. Use approved gasoline container.
 - B. Never remove cap or add gasoline to a running or hot engine or fill fuel tank indoors. Wipe up spilled gasoline.
 - C. Open doors if engine is run in garage. Exhaust fumes are dangerous. Do not run engine indoors.

Rules for Safe Operation (continued)

26. Keep the vehicle and attachments in good operating condition, and keep safety devices in place. Use guards as instructed in operator's manual.
27. Keep all nuts, bolts, and screws tight to be sure the equipment is in safe working condition.
28. Never store the machine with fuel in the fuel tank inside a building where ignition sources are present, such as hot water and space heaters, clothes dryers, and the like. Allow the engine to cool before storing in any enclosure.
29. To reduce fire hazard, keep engine free of grass, leaves or excessive grease.
30. The vehicle and attachments should be stopped and inspected for damage after striking a foreign object. The damage should be repaired before restarting and operating the equipment.
31. Do not change the engine governor settings or overspeed the engine.
32. When using the vehicle with mower, proceed as follows:
 - (1) Mow only in daylight or in good artificial light.
 - (2) Never make a cutting height adjustment while engine is running if operator must dismount to do so.
 - (3) Shut the engine off and wait until the blade comes to a complete stop before removing the grass catcher.
 - (4) Check blade mounting bolts for proper tightness at frequent intervals.
33. Check grass catcher bags frequently for wear or deterioration. For safety protection, replace only with new bag meeting original equipment specifications.
34. Look behind to make sure the area is clear before placing the transmission in reverse and continue looking behind while backing up. Disengage blades before shifting into reverse and backing up.
35. This unit should not be driven up a ramp onto a trailer or truck under power, because the unit could tip over, causing serious personal injury. The unit must be pushed manually to load properly.

 **IMPORTANT:** This unit is shipped **WITHOUT GASOLINE or OIL**; however, a small amount of oil may be present from the factory. Do not overfill. After assembly, service engine with gasoline and oil as instructed in the separate engine manual packed with your unit.

 **NOTE:** Reference to right or left hand side of the unit is observed from the driver's seat, facing forward.

ASSEMBLY

UNPACKING

1. Remove the lawn tractor from the carton as follows. Open the top flaps. Remove all loose parts and carton inserts. Cut the front corners of the carton. Make certain brake is released, and push the unit out of the carton.
2. Remove page four from this manual and lay the contents of the hardware pack on the illustration for identification.

BATTERY INFORMATION



WARNING

- A. Battery acid must be handled with great care as contact with it can burn and blister the skin. It is also advisable to wear protective clothing (goggles, rubber gloves and apron) when working with it.*
 - B. Should battery acid accidentally splatter into the eyes or onto the face, rinse the affected area immediately with clean cold water. If there is any further discomfort, seek prompt medical attention.
 - C. If acid spills on clothing, first dilute it with clean water, then neutralize with a solution of ammonia/water or baking soda/water.
 - D. Since battery acid is corrosive, do not pour it into any sink or drain. Before discarding empty electrolyte containers, rinse them with a neutralizing solution.
 - E. NEVER connect or disconnect charger clips to battery while charger is turned on as it can cause sparks.
 - F. Keep all lighted materials (cigarettes, matches, lighters) away from the battery as the hydrogen gas generated during charging can be combustible.
 - G. As a further precaution, only charge the battery in a well-ventilated area.
- *Always shield eyes, protect skin and clothing when working near batteries.**

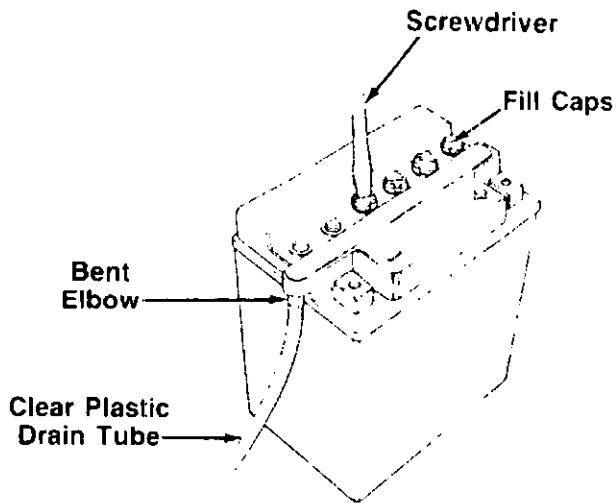

FIGURE 1.



FIGURE 2.



Battery contains sulfuric acid. Refer to warning on page 6. Antidote: **EXTERNAL**—Flush with water. **INTERNAL**—Drink large quantities of water or milk. Follow with milk of magnesia, beaten eggs or vegetable oil. Call physician immediately. **EYES:** Flush with cool water for at least 15 minutes, then get prompt medical attention.

Since batteries produce explosive gases, keep all lighted materials (cigarettes, lighters, matches, etc.) away. Be sure to charge battery only in well-ventilated areas. Make certain venting path of battery (drain tube) is always open.

**KEEP BATTERIES
OUT OF THE REACH OF CHILDREN!**

ACTIVATING THE BATTERY

Do not activate battery (fill with battery acid) until battery is actually placed in service. Be certain to read previous warnings before activating the battery.

1. Open the battery pack. Be careful not to puncture the box. It contains the battery with a long plastic tube attached, battery fluid (acid) in a plastic container, one short plastic tube and one hardware pack (two hex bolts and nuts).
2. Place the battery on a table or workbench. Make certain the long plastic drain tube is in place on the vent elbow.
3. Remove the six fill caps from the top of the battery with a screwdriver. Be careful not to damage the fill caps. See figure 1.
4. Place the battery fluid container on the table or workbench. Carefully cut off tip of the spout and attach the short plastic tube provided. Do not squeeze the container when cutting tip.
5. Fill each battery cell slowly and carefully to the **UPPER LEVEL** line marked on battery. Use caution as the acid level will rise rapidly after the bottom of the cell is filled.
6. Allow battery to stand for 30 minutes with the fill caps removed, while the plates absorb acid.
7. If acid level has fallen after the 30 minute standing period, refill each cell with battery acid to the **UPPER LEVEL** line on battery. Replace the fill caps.
8. Before discarding the empty container, neutralize any residue with baking soda and rinse container with water. Puncture container several times before discarding.
9. Charge the battery after the 30 minute standing period. **SLOW CHARGE THE BATTERY (DO NOT FAST CHARGE)** at a maximum bench rate of 1.4 amperes until the specific gravity reading is 1.260-1.280. Charge for a minimum of 2 hours and a maximum of 8 hours.

NOTE

Charging rate after battery has been put into operation: The battery is to be charged for a period of 14-16 hours. **NO LONGER THAN 30 HOURS.**

After battery has been charged, add only distilled water. Do not add acid.

NOTE

This engine is equipped with an alternator. The current for the battery charger alternator is unregulated. During normal operation, it is only necessary to charge the battery:

1. When it is activated for the first time.
2. Before winter storage.
3. Before using the lawn tractor after winter storage.

INSTALLING THE BATTERY (Hardware A)

- ← 1. Raise the seat bracket (on top of the fenders). Push any electrical wires out of the way so they are not disconnected when installing the battery box. Place the plastic battery box into the opening beneath the seat bracket. The hinge on the battery box goes toward the left side of the unit. Snap the battery box in place so the retaining edges on the box are beneath the fender. Make certain the battery cables are routed up along each side of the box. See figure 3.

2. Place the battery inside the battery box so that the positive terminal is toward the right side of the unit. See figure 3. Route the battery drain tube down beside the battery box.
3. Slide the hex nut (provided with battery hardware) into the positive (+) terminal. Place the positive (heavy red wire) cable on the positive terminal. Secure with bolt provided. See figure 3. Slide the rubber boot over the positive terminal.
4. Slide the hex nut (provided with battery hardware) into the negative (-) terminal. Place the negative (heavy black wire) cable on the negative terminal. Secure with bolt provided.

- ← 5. Route the drain tube through the opening between the transaxle reinforcement bracket and the frame on the left rear of the unit. Secure the drain tube to the transaxle reinforcement bracket, using the cable tie as shown in figure 4. Be certain drain tube is routed away from the wheel rim. Trim excess end of cable tie.

6. Close the top of the battery box.

INSTALLING THE STEERING MECHANISM (Hardware B)

1. Open the hood of the lawn tractor by lifting up on both sides of the hood. Position the front wheels of the tractor so they are pointing straight forward.
- ← 2. Insert the hex bearing into the hole in the frame shown in figure 5.
3. Insert the end of the steering shaft which has the pinion gear attached through the hole in the dash panel. Place 5/8" I.D. flat washer on the end of the steering shaft, and insert shaft through hex bearing. Make certain the pinion gear is fully seated against the flat washer and hex bearing.

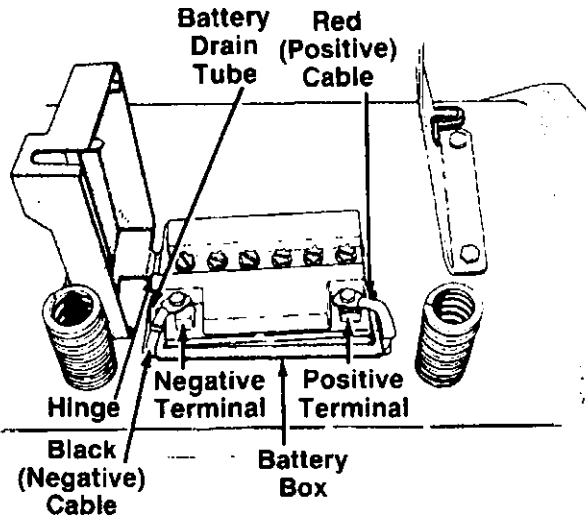

FIGURE 3.

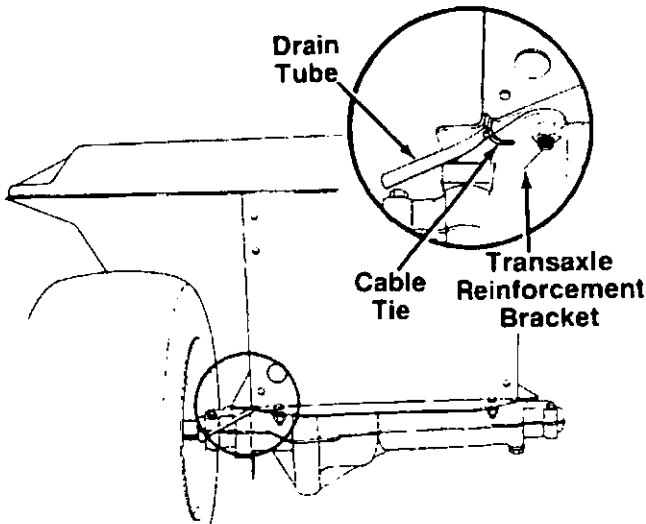

FIGURE 4.

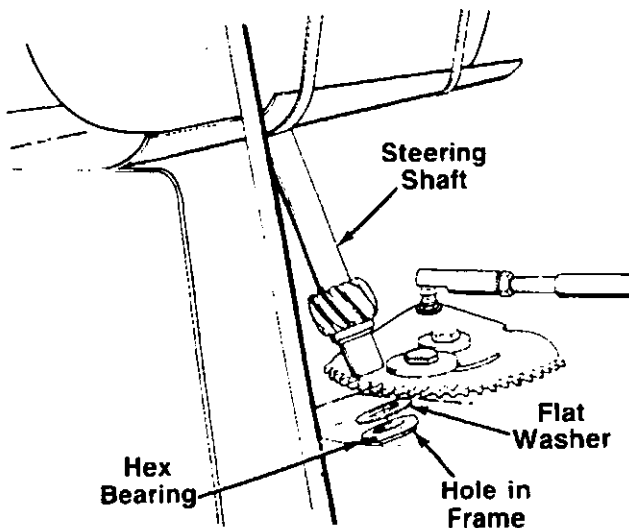

FIGURE 5.

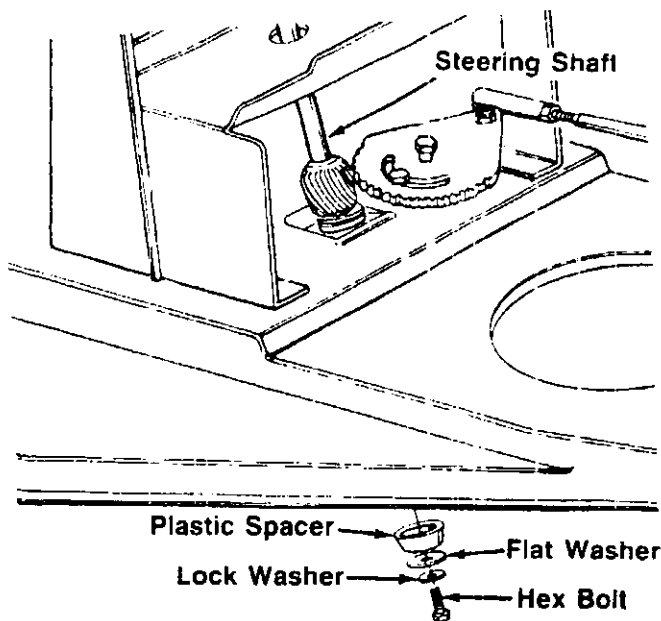

FIGURE 6.

4. Secure bottom of the steering shaft as follows. See figure 6.

- a. Lower the deck by moving the lift and disengagement lever (located on the right fender) all the way down.
- b. Place the plastic spacer over the end of the steering shaft. Secure with 5/16" I.D. flat washer, lock washer and hex bolt. A 1/2" wrench is required (socket wrench with an extension would be helpful).

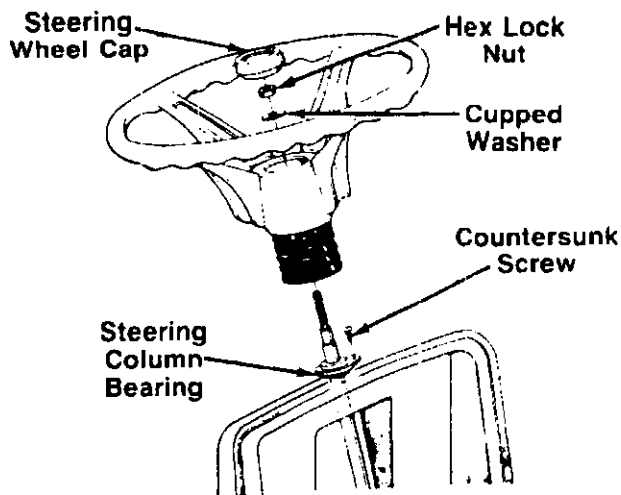

FIGURE 7.

5. Place the steering column bearing (solid side up) over the upper end of the steering shaft. Seat the steering column bearing into the hole in the dash panel. Secure with countersunk screw. See figure 7.

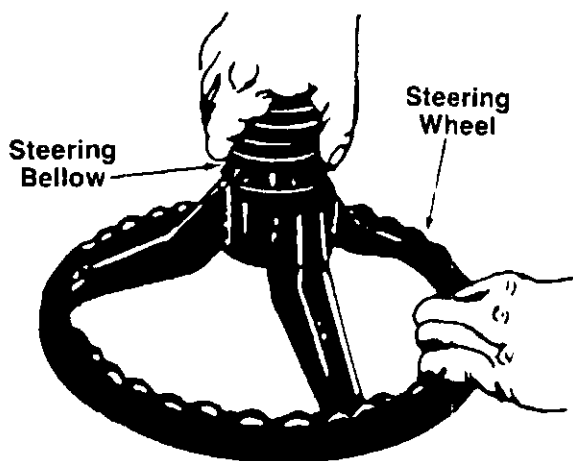

FIGURE 8.

6. Attach one end of steering bellow to the steering wheel as shown in figure 8.

7. With the wheels of the tractor pointing straight forward, place the steering wheel and steering bellow over the steering shaft, positioning steering wheel as desired.

8. Place the washer with the cupped side down over the steering shaft. Secure with 5/16" hex lock nut. See figure 7.

9. Place the steering wheel cap over the center of the steering wheel and seat it with your hand.

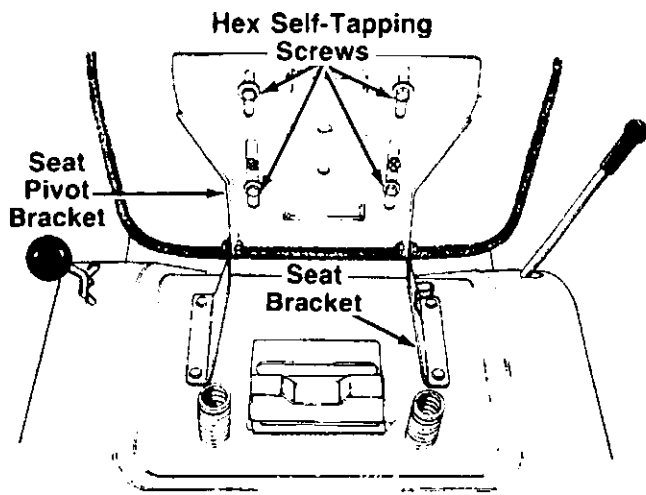

FIGURE 9.

ATTACHING THE SEAT (Hardware C)

Place the seat in position against the seat pivot bracket, lining up the slotted holes in the pivot bracket with the holes in the seat. Select desired position for the seat, ← and secure with hex self-tapping screws. See figure 9.

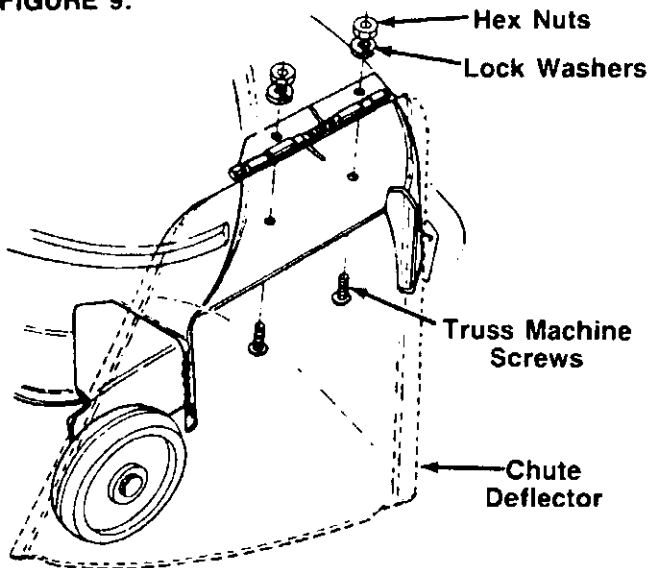

FIGURE 10.

ATTACHING THE CHUTE DEFLECTOR (If Unassembled)

If the chute deflector has not been assembled on your unit, remove the truss machine screws, lock washers and hex jam nuts which are attached to the deck next to the chute opening.

Place the chute deflector in position as shown in figure ← 10. Secure with hardware just removed.



WARNING

Do not operate your unit unless the chute deflector has been properly installed.

CONTROLS

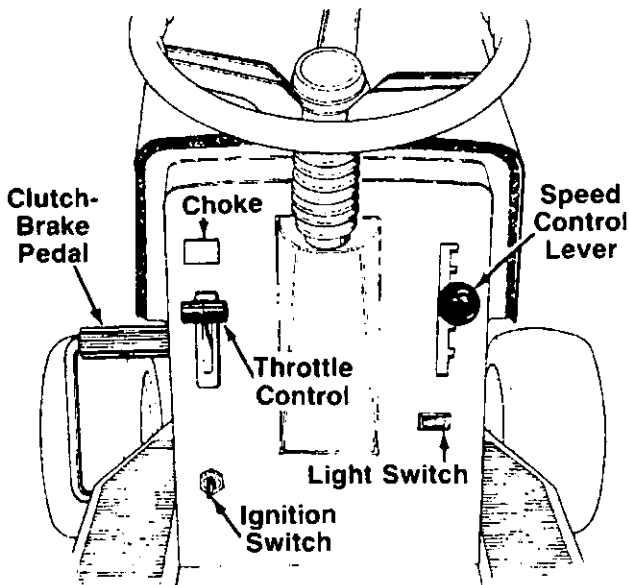

FIGURE 11.

THROTTLE CONTROL

The throttle control is used to regulate the engine speed. To get maximum efficiency from cutting, the throttle should be in the FAST position when operating the mower. See figure 11.

CHOKE CONTROL

The choke control is located on the dashboard and is operated manually. Details for the choke operation are covered in the separate engine manual packed with your unit. See figure 11.

SPEED CONTROL LEVER

The speed control lever allows you to regulate the ground speed of the lawn tractor. See figure 11. To select the ground speed, depress clutch pedal. Push speed control lever inward and move downward to slow lawn tractor, move upward to increase speed. When desired speed has been obtained, release lever in that position. Whenever clutch is engaged, unit will automatically go to the pre-set speed.

IGNITION SWITCH

Turn the key to the START position to start the engine. When the engine is running, let the key return to the ON position. To stop the engine, turn the key to the left to the OFF position and remove it to prevent accidental starting. See figure 11.

LIGHT SWITCH

Push the light switch to turn on the lights. The lights will only operate when the engine is running. See figure 11.

GEAR SHIFT LEVER

The shift lever is located on the left fender and has three positions, FORWARD, NEUTRAL and REVERSE. See figure 12. The clutch-brake pedal must be depressed and the lawn tractor must not be moving when shifting gears. Do not force the shift lever. Release the clutch-brake pedal slightly to line up the shifting collar in the transmission. Then try to shift gears.

CLUTCH-BRAKE PEDAL

The clutch-brake pedal is located on the left side of the lawn tractor. Depressing the clutch-brake pedal part way disengages the clutch. Pressing the pedal all the way down disengages the clutch and engages the disc brake. See figure 11.



The clutch-brake pedal must be depressed to start the engine

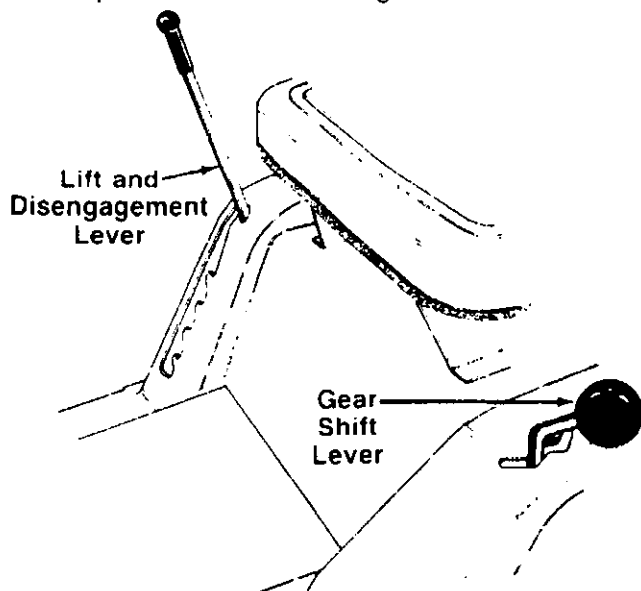

FIGURE 12.

PARKING BRAKE

The speed control lever is used to set the parking brake. To set the parking brake, depress the clutch-brake pedal. Press the speed control lever inward and all the way down. Release the speed control lever and the clutch-brake pedal.

To release the parking brake, depress the clutch-brake pedal, press the speed control lever inward and move to desired position. Release the speed control lever and the clutch-brake pedal.

INTERLOCKS (Not Shown)

Interlock safety switches are located on the clutch-brake pedal, the lift and disengagement lever, the gear shift lever and under the seat.

Before the engine will start, the clutch-brake pedal must be depressed all the way and the lift and disengagement lever must be in the disengaged position.

Before the unit can be shifted into reverse or if the operator leaves the seat, the lift and disengagement lever must be in the disengaged position.

CUTTING CONTROLS

A. LIFT AND DISENGAGEMENT LEVER

The lift and disengagement lever is used to raise and lower the cutting deck which determines the cutting height. Pulling it all the way back and locking it disengages the blades. The lift and disengagement lever **must** be in the disengaged position when starting the engine, when shifting into reverse or if the operator leaves the seat. See figure 12.

B. DECK WHEEL HEIGHT ADJUSTMENT

Set the deck wheels so that the wheels are $\frac{1}{4}$ to $\frac{1}{2}$ inch above the ground, by moving the deck wheels to the desired hole location in the deck.

OPERATION

CAUTION

- READ OPERATOR'S MANUAL(S) • NEVER CARRY CHILDREN
- KNOW LOCATION AND FUNCTION OF ALL CONTROLS
- KEEP SAFETY DEVICES (GUARDS, SHIELDS AND SWITCHES) IN PLACE AND WORKING
- REMOVE OBJECTS THAT COULD BE THROWN BY BLADE(S)
- DO NOT OPERATE THE UNIT WHEN CHILDREN AND OTHERS ARE AROUND
- ALWAYS LOOK BEHIND THE UNIT BEFORE BACKING UP
- DO NOT OPERATE THE UNIT WHERE IT COULD SLIP OR TIP
- IF THE UNIT STOPS GOING UPHILL, STOP BLADE(S) AND BACK SLOWLY DOWNHILL
- BE SURE BLADE(S) AND ENGINE ARE STOPPED BEFORE PLACING HANDS OR FEET NEAR BLADE(S)
- BEFORE LEAVING OPERATOR'S POSITION, SHUT ENGINE OFF AND REMOVE KEY

TIRE PRESSURE

For shipping purposes, the tires on your unit may be over-inflated. Tire pressure should be reduced before unit is put into operation. Recommended operating tire pressure should be 10 p.s.i.

Check sidewall of tire for manufacturer's maximum tire pressure. If this information does not appear on your tire, maximum tire pressure under any circumstances is 30 p.s.i. Equal tire pressure should be maintained on all tires.

STARTING THE ENGINE

➡ NOTE

To open the hood, simply lift up on both sides of the hood.

1. Service the engine with oil and gasoline as described in the engine manual.
2. Depress the clutch-brake pedal and set the parking brake.
3. Place the lift and disengagement lever in the DISENGAGED position. See figure 12.

➡ NOTE

This unit is equipped with a **safety interlock system** for your protection. The purpose of the safety interlock system is to prevent the engine from cranking or starting unless the clutch-brake pedal is depressed and the lift and disengagement lever is in the disengaged position. In addition, the lift and disengagement lever must be in the disengaged position when the unit is put into reverse or the engine will shut off. If the operator leaves the seat with the lift and disengagement lever engaged, the engine will shut off.



Do not operate the lawn tractor if the interlock system is malfunctioning because it is a safety device, designed for protection.

4. Set the throttle control in the FAST position. See figure 11.
5. Pull out choke knob to choke engine.

➡ NOTE

A warm engine may not require choking.

6. Turn the ignition key to the START position. When the engine is running, let the key return to the ON position. See figure 11.
7. Push choke knob in gradually. Move the throttle control to desired engine speed.

STOPPING THE ENGINE

Turn the ignition key to the left to the OFF position. Remove the key to prevent accidental starting.

➡ NOTE

A brief break-in period is essential to ensure maximum engine and mower life. The break-in consists of running the engine at half speed for a period of time required to use one tank of gasoline. It is also recommended to change crankcase oil after the first 5 hours of operation.

Be sure that the lawn is clear of stones, sticks, wire, or other objects which could damage lawn tractor or engine. For best results and to insure more even grass distribution, do not mow when lawn is excessively wet.

➡ IMPORTANT

If you strike a foreign object, stop the engine. Remove wire from spark plug, thoroughly inspect the unit for any damage, and repair the damage before restarting and operating the mower.

➡ NOTE

If any problems are encountered, refer to the Trouble Shooting Chart on page 21.

OPERATING THE LAWN TRACTOR

1. Start the engine as instructed in previous column.
2. Move throttle control to $\frac{3}{4}$ or full throttle to prevent strain on the engine and to operate the cutting blades.
3. Place the shift lever in either the FORWARD or REVERSE position.



CAUTION

Look to the rear before backing up.

4. Release the parking brake by depressing the clutch-brake pedal, pressing outward on the speed control lever and moving to desired position.

➡ NOTE

Use first speed position when operating operating the lawn tractor for the first time.

5. Release clutch-brake pedal slowly to put unit into motion.
6. The lawn tractor is brought to a stop by depressing the clutch-brake pedal.

➡ NOTE

When operating the unit initially, there will be little difference between the highest two speeds until after the belts have seated themselves into the pulleys during the break-in period.



CAUTION

If the unit is not to be used for a long period, place the gear shift lever in NEUTRAL, stop the engine, set the parking brake and remove the key. DO NOT leave the machine on an incline.

If unit stalls with speed control in high speed, or if unit will not operate with speed control lever in a low speed position, proceed as follows.

1. Place shift lever in NEUTRAL.
2. Restart engine.
3. Place speed control lever in high speed position.
4. Release clutch-brake pedal fully.
5. Depress clutch-brake pedal.
6. Place speed control lever in desired position.
7. Place shift lever in either FORWARD or REVERSE, and follow normal operating procedures.

OPERATING THE CUTTING BLADES

The cutting blades may be engaged while the lawn tractor is moving or standing still. DO NOT engage the cutting blades abruptly as the sudden belt tension on the pulley may cause the engine to stall.



WARNING

When the blade drive is engaged, keep feet and hands away from the discharge opening, the blades or any part of the deck.

Move the lift and disengagement lever into the DISENGAGED position to raise the deck and disengage the blades.



NOTE

When the machine is used for other than mowing operations, the blade drive should be disengaged.

GRASS COLLECTOR Stock Number 89-35108R is available as optional equipment for the lawn tractor shown in this manual.



WARNING

The mower should not be operated without the entire grass catcher or chute deflector in place.



NOTE

Under normal usage bag material is subject to wear, and should be checked periodically. Be sure any replacement bag complies with the mower manufacturer's recommendations.

For replacement bags, use only factory authorized replacement bag.

ADJUSTMENTS

SEAT ADJUSTMENT

To adjust the position of the seat, loosen the four self-tapping screws on the bottom of the seat. See figure 9. Slide the seat forward or backward as desired. Retighten the self-tapping screws.

DECK LEVELING ADJUSTMENT

If an uneven cut is obtained, the deck may be leveled as follows.

1. Move the lift and disengagement lever forward (lower the cutting deck). Make certain the deck wheels are not resting on the ground.
2. Using a 1/2" wrench, loosen the jam nut located at the right rear deck link. See figure 13. It may be helpful to raise the cutting deck slightly to loosen the jam nut and to move the adjusting screw.

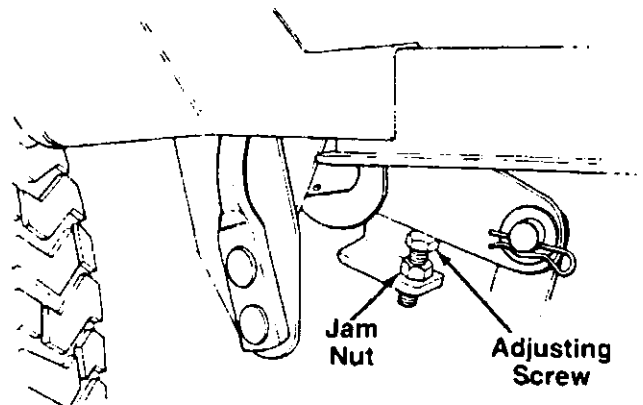

FIGURE 13.

3. With unit on hard, level surface, measure the distance from the bottom edge of the center of the left side of deck to the ground. Measure the same distance just behind the chute area on the right side of the deck. Or, place the blades in a straight line, and measure the distance from the outside edge of the blade tips to the ground.

- Adjust the deck as follows: To raise the right side of the deck, tighten the adjusting screw. To lower the right side of the deck, back the adjusting screw off several turns. Remeasure the deck as described in step 3, and readjust if necessary. Tighten the jam nut to secure the adjusting screw when the deck is level.

SPEED CONTROL ADJUSTMENT (See figure 14)

NOTE

When operating the unit initially or after replacing the belts, there will be little difference between the highest two speeds until after the belts have gone through a break-in period and have seated themselves into the pulleys.

First, adjust the speed control lever by pushing the clutch-brake pedal forward until the stop on the brake rod is $1/8''$ to $1/4''$ away from the variable speed pulley bracket. See figure 14. Have another person hold the pedal in this position as you make the following adjustment. Place the speed control lever in parking brake position. Remove the hairpin cotter and flat washer from the rod attached to the back of the speed control lever. Adjust the ferrule on the rod so the stop on the brake rod is between $1/8''$ and $1/4''$ away from the bracket. See figure 14. Replace the flat washer and hairpin cotter.

Next, adjust the speed control link as follows to obtain the correct neutral adjustment.

- Start the engine.
- Place the shift lever in Neutral position.
- Place the speed control lever in high speed position.
- Release the clutch-brake pedal completely, then slowly depress the pedal all the way (to park position). Hold the pedal in this position.
- Turn the engine off.
- After engine stops completely, release the clutch-brake pedal.
- Place speed control lever in first position.
- Remove the cotter pin and flat washer which secures the ferrule on the speed control link to the bracket on the clutch-brake pedal assembly.
- Push the clutch-brake pedal backward by hand as far as it will go using light pressure. Hold it in this position as you thread the ferrule on or off the speed control link until it lines up with the hole in the clutch-brake pedal assembly.
- Secure the ferrule on the speed control link to clutch-brake pedal assembly with flat washer and cotter pin.

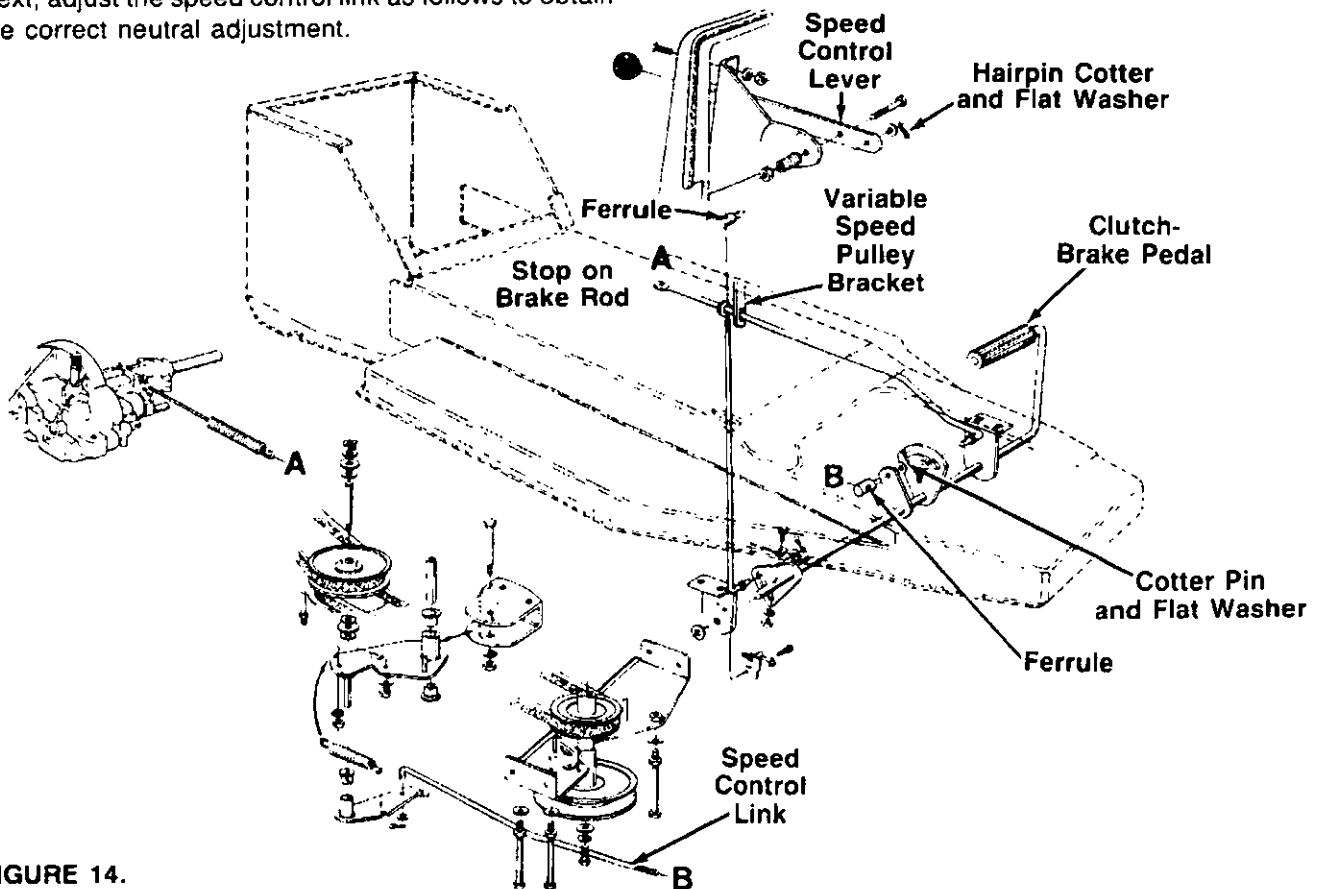

FIGURE 14.

NEUTRAL ADJUSTMENT (Wheel Drive)

1. Place the transmission in neutral. (The unit will move freely when pushed forward and backward with the parking brake released)
2. Loosen the bolt which secures the shift lever assembly to the shift lever adjusting link. See figure 15.
3. Place the shift lever in the neutral slot. See figure 15.
4. Tighten the bolt to 13 foot pounds.

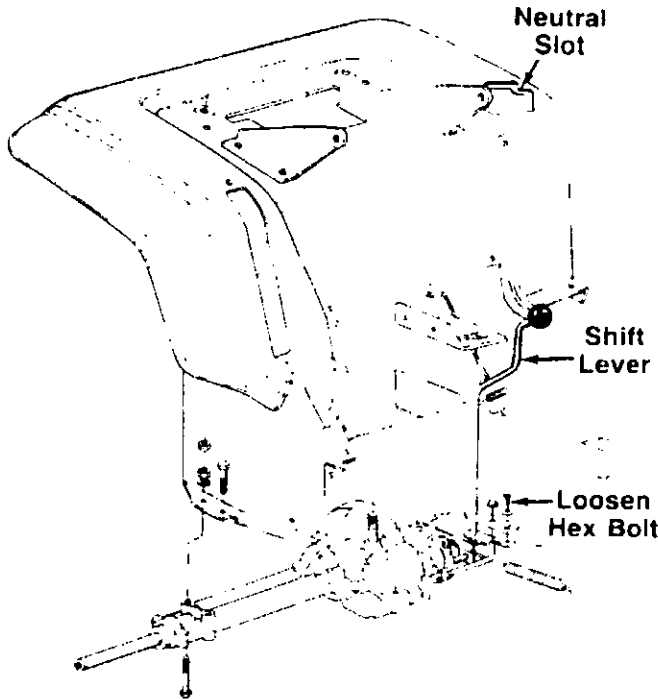

FIGURE 15.

CUTTING DECK ENGAGEMENT ADJUSTMENT

The cutting deck engagement may be adjusted to make certain deck is disengaged when lift handle is in the disengaged position, or to obtain more drive in the cutting positions. Correct adjustment as follows.

Place the lift handle in the highest cutting position (first notch down from disengaged position) The jam nuts on the threaded rod (above the rear of the deck) should be approximately 1/16" from the end of the tubing. See figure 16.

Move the jam nuts down the threaded rod to start to disengage the deck earlier. Move the jam nuts up to obtain more drive in the cutting positions.



WARNING

Make certain the unit is adjusted so that the cutting blades are disengaged when the lift handle is in the disengaged position.

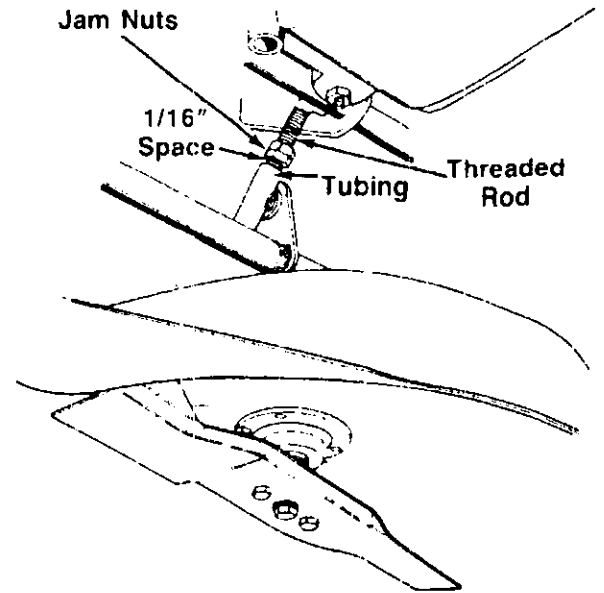

FIGURE 16.

WHEEL ADJUSTMENT

The caster (forward slant of the king pin) and the camber (tilt of the wheels out at the top) require no adjustment. Automotive steering principles have been used to determine the caster and camber on the tractor. The front wheels should toe-in 1/8 inch.

To adjust the toe-in, follow these steps.

1. Remove the cotter pin and flat washer from the ferrule on the tie rod end on the right side of the tractor. See figure 17.

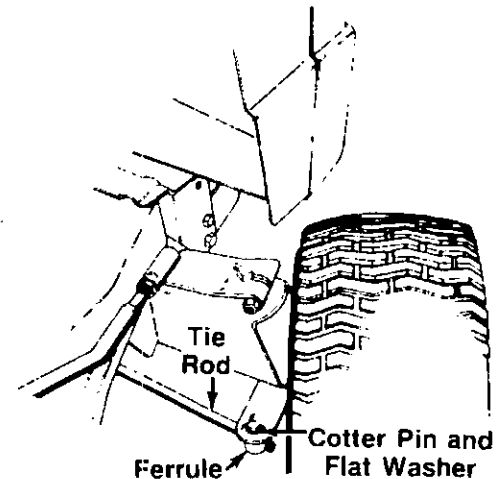

FIGURE 17.

2. Adjust the tie rod for correct toe-in by threading the ferrule in or out as necessary.

Dimension "B" should be approximately 1/8" less than Dimension "A." See figure 18.

- A.) To increase Dimension "B," thread the ferrule onto the tie rod.
- B.) To decrease Dimension "B." unscrew the ferrule from the tie rod.

C.) Reassemble tie rod. Check dimensions. Readjust if necessary.

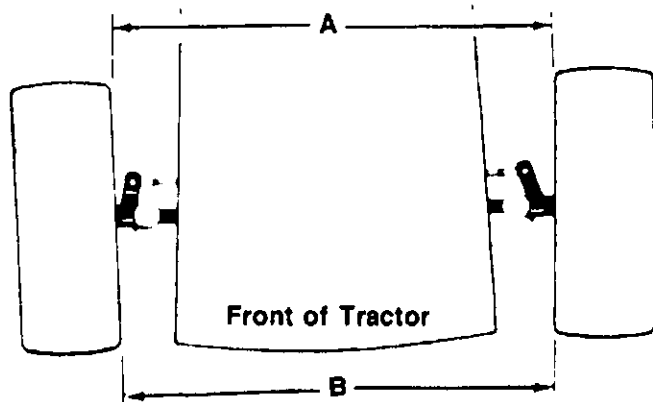

FIGURE 18. TOE-IN DIAGRAM

CARBURETOR ADJUSTMENT



WARNING

If any adjustments are made to the engine while the engine is running (e.g. carburetor), disengage all clutches and blades. Keep clear of all moving parts. Be careful of heated surfaces and muffler.

Minor carburetor adjustment may be required to compensate for differences in fuel, temperature, altitude and load. To adjust the carburetor, refer to the separate engine manual packed with your unit.



NOTE

A dirty air cleaner will cause an engine to run rough. Be certain air cleaner is clean and attached to the carburetor before adjusting carburetor. Refer to the separate engine manual.

BRAKE ADJUSTMENT (See figure 19)

The brake is located by the left rear wheel inside the frame. During normal operation of this machine, the brake is subject to wear and will require periodic examination and adjustment.



WARNING

Do not have the engine running when you adjust the brake.

To adjust the brake, remove the cotter pin. Adjust the castle nut so the brake starts to engage when the brake lever is $\frac{1}{4}$ " to $\frac{5}{16}$ " away from the axle housing.



NOTE

Figure 19 is shown with the unit tipped up on rear wheels for clarity only.

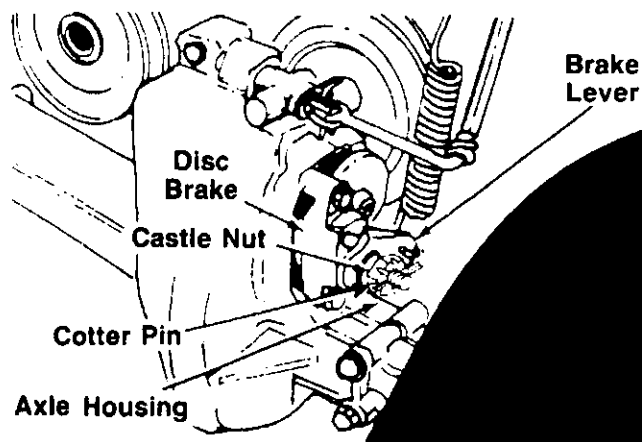

FIGURE 19.

LUBRICATION



WARNING

Always stop engine and disconnect spark plug wire before cleaning, lubricating or doing any kind of work on lawn tractor.

STEERING GEARS

Lubricate teeth of steering gears with automotive multi-purpose grease after every 25 hours of operation or once a season.

STEERING SHAFT

Lubricate steering shaft at least once a season with light oil.

TRANSAXLE

The transaxle is lubricated and sealed at the factory and does not require checking. If disassembled for any reason, lubricate with 10 oz. of grease, part number 737-0148.

FRONT WHEELS

The front wheels are provided with grease fittings. Lubricate at least once a season with automotive multi-purpose grease.

PIVOT POINTS

Lubricate all pivot points with light oil at least once a season.

MAINTENANCE



Disconnect the spark plug wire and ground against the engine before performing any repairs or maintenance.

TROUBLE SHOOTING

Refer to page 21 of this manual for trouble shooting information.

CRANKCASE OIL

Check the oil level in the crankcase before each use of the machine and after every five hours of operation. Oil level should be maintained as instructed in the separate engine manual.

After the first five hours of operating a new engine, drain the oil from the crankcase while engine is still hot and refill crankcase with new oil; thereafter change the oil every 25 hours of operation. Refer to the engine manual.

AIR CLEANER

Under normal operating conditions, the air cleaner, located on top of the carburetor, must be serviced after every ten hours of use. Under extremely dusty operating conditions, the air cleaner must be serviced after every hour of operation. To service the air cleaner, refer to the separate engine manual packed with your unit.

CLEANING ENGINE AND BLADE HOUSING

Any fuel or oil spilled on the machine should be wiped off promptly. Grass, leaves, and other dirt must not be left to accumulate around the cooling fins of the engine or on any part of the machine.

Clean the underside of the blade housing after each mowing.

SPARK PLUG

The spark plug should be cleaned and the gap reset once a season. Spark plug replacement is recommended at the start of each mowing season; check engine manual for correct plug type and gap specification.

CUTTING BLADE

A. Removal for Sharpening or Replacement



Be sure to disconnect and ground the spark plug wire and remove ignition key before working on the cutting blade to prevent accidental engine starting. Protect hands by using heavy gloves or a rag to grasp the cutting blades.

1. Remove the large bolt and lock washer which holds the blade and adapter to the blade spindle.
2. Remove the blade and adapter from the spindle.
3. If the blade or blade adapter needs replacing, remove the two small bolts, lock washers and nuts which hold the blade to the adapter.

B. Sharpening

Remove the cutting blade by following the directions of the preceding section.

When sharpening the blade, follow the original angle of grind as a guide. It is **extremely important** that each cutting edge receives an equal amount of grinding to prevent an unbalanced blade. An unbalanced blade will cause excessive vibration when rotating at high speeds, may cause damage to the mower and could break, causing personal injury.

The blade can be tested for balance by balancing it on a round shaft screwdriver. Remove metal from the heavy side until it balances evenly.



It is recommended that the blade always be removed from the adapter for the best test of balance.

C. Reassembly

Before reassembling the blade and the blade adapter to the unit, lubricate the spindle and the inner surface of the blade adapter with light oil. Lubricating the bolt holes, bolts and inner surface of the nuts with light oil is also recommended. A 4 oz. plastic bottle of light oil lubricant is available. Order part number 737-0170. Engine oil may also be used.

When replacing the blade, be certain the wide blade is assembled on the right side of the deck. Be sure to install the blades with the side of the blades marked "Bottom" (or with part number) facing the ground when the mower is in the operating position.

Blade Mounting Torque

3/8" Dia. Bolt 375 in. lb. min., 450 in. lb. max.
5/16" Dia. Bolt 150 in. lb. min., 250 in. lb. max.

To insure safe operation of your unit, ALL nuts and bolts must be checked periodically for correct tightness.

FUEL FILTER

Your unit is equipped with a replaceable in-line fuel filter. Replace filter whenever contamination or discoloration is noticed. Order replacement filter through your engine authorized service dealer.

DRIVE BELT REMOVAL AND REPLACEMENT



Disconnect the spark plug wire and ground it against the engine. Block the wheels of the unit.

NOTE

When changing the rear drive belt, a spring puller or other suitable tool is required to remove an extension spring. A spring puller (part number 732-0571) is available to assist in removal of this spring.

NOTE

Figures 20, 24 and 25 are shown with the unit tipped up for clarity. It is not necessary to tip the unit to remove the belts.

Removing the Deck Belt

1. Place the lift lever in the disengaged position.
2. Remove the three hex bolts (belt keepers) from the engine pulley belt guard. See figure 20.

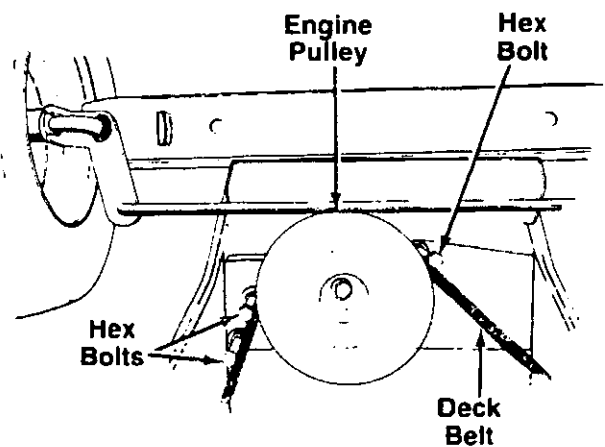

FIGURE 20.

NOTE

Make certain hex bolts are reassembled as shown in figure 20.

3. Unhook the deck belt from the engine pulley.
4. Place the lift lever in the engaged (all the way forward) position.
5. Disconnect the spring from the left rear deck bracket. See figure 21.
6. Disconnect the top of the four deck links by removing the hairpin clips and flat washers.
7. Slide the threaded rod out of the tubing. See figure 21. Slide the deck from beneath the lawn tractor.

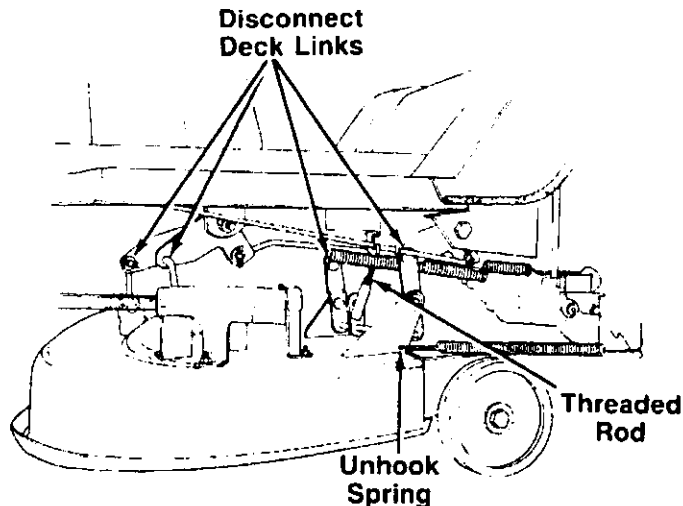

FIGURE 21.

8. Remove the belt guards at each deck pulley by removing the hex bolts, lock washers and hex nuts. See figure 22.
9. Remove and replace the belt, following the instructions in reverse order.

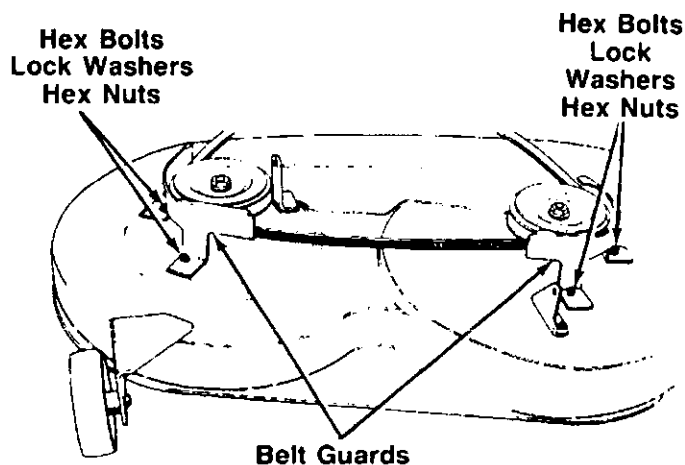

FIGURE 22.

Removing the Rear Drive Belt (Refer to figure 24)

1. Remove the cutting deck, following steps 1 through 7 of "Removing the Deck Belt" instructions.
2. Start the engine. Place shift lever in neutral. Place speed control lever in high speed position and turn engine off. Do not set parking brake.
3. Disconnect the large spring from the transmission support bracket, using a spring puller or other suitable tool. An access hole is provided in the rear of the frame for this purpose. See figure 23.

NOTE

A spring puller (part number 732-0571) is available to assist in removal of this spring.

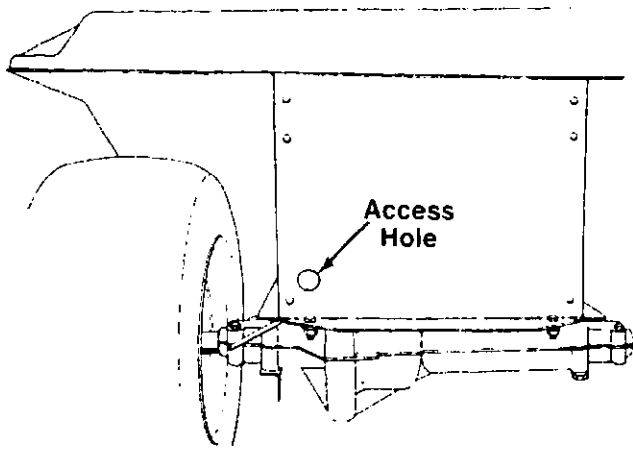

FIGURE 23.

4. Disconnect the small spring from the bolt on the right side of the frame and transmission support bracket.
5. Remove the brake rod out of the variable speed pulley bracket.
6. Loosen (**do not** remove) the bolts which secure the variable speed pulley bracket to allow clearance in order to remove the belts. A 7/16" socket wrench with extension is required.
7. Remove the rear drive belt from around the top of the variable speed pulley. Remove belt from transmission pulley and idler pulley.
8. Reassemble new belt, following instructions in reverse order

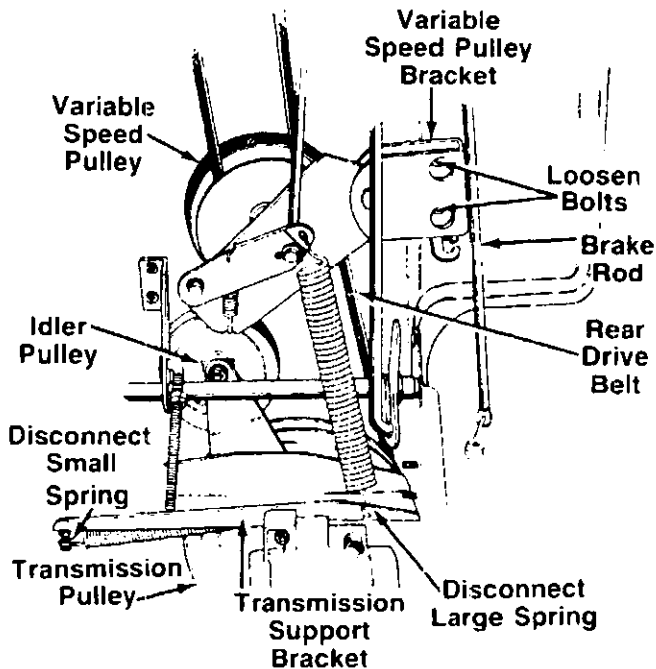

FIGURE 24.

Removing the Forward Drive Belt (See figure 25)

1. To remove the forward drive belt, first remove the rear drive belt (steps 1 through 7 of the preceding instructions)
2. Remove the engine pulley belt guard by removing two self-tapping screws from each side of the frame. Remove the engine pulley belt guard by moving it back and to the left.
3. Remove the forward drive belt from the engine pulley and from the variable speed pulley.
4. Reassemble new belt, following instructions in reverse order.

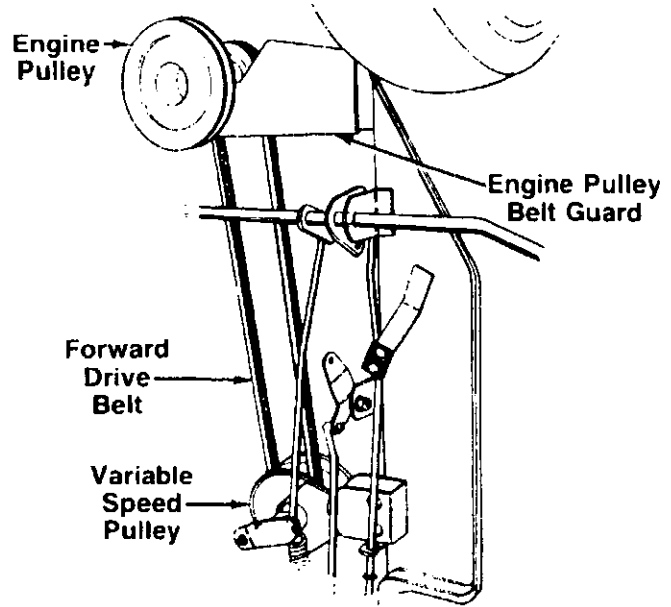

FIGURE 25.

BATTERY REMOVAL OR INSTALLATION



WARNING

When removing the battery, follow this order of disassembly to prevent the screwdriver from shorting against the frame.

1. Remove the Negative cable.
2. Remove the Positive cable.

To install a battery:

1. Attach the Positive cable.
2. Attach the Negative cable.

JUMP STARTING

1. Attach the first jumper cable from the Positive terminal of the good battery to the Positive terminal of the dead battery.
2. Attach the second jumper cable from the Negative terminal of the good battery to the FRAME OF THE UNIT WITH THE DEAD BATTERY.



WARNING

Failure to use this starting procedure could cause sparking, and the gas in either battery could explode.

BATTERY MAINTENANCE

1. Check periodically (every two weeks or before and after charging) to be sure electrolyte level is above the lowest line on battery. Add only distilled water or a good quality drinking water. NEVER add additional acid or other chemicals to battery after initial activation.
2. The battery should be checked with a hydrometer after every 25 hours of operation. If the specific gravity is less than 1.225, remove battery and recharge.
3. Coat the terminals and exposed wiring with a thin coat of grease or petroleum jelly for longer service and protection against electrolyte corrosion.
4. The battery should be kept clean. Any deposits of acid should be neutralized with soda and water. Be careful not to get this solution in the cells.

BATTERY STORAGE

1. Charge battery using normal methods. NEVER store discharged battery as it will not recover.
2. When storing battery for extended periods, disconnect battery cables. Removing battery from unit is recommended.
3. Store in cold, dry place.
4. Recharge battery whenever the specific gravity is less than 1.225, before returning to service, or every two months, whichever occurs first.

COMMON CAUSES FOR BATTERY FAILURE ARE:

1. Overcharging
2. Undercharging
3. Lack of water
4. Loose hold downs and/or corroded connections
5. Excessive loads
6. Battery electrolyte substitutes
7. Freezing of electrolyte

NOTE

THESE FAILURES DO NOT CONSTITUTE WARRANTY.

INSTALLATION OF TIRE TO RIM



WARNING

The following procedure must be followed when removing or installing a tire to the rim.

1. Be sure rim is clean and rust free.
2. Lubricate both the tire and rim generously.
3. Never inflate to over 30 p.s.i. to seat beads. Excessive inflation pressure when seating beads may cause tire/rim assembly to burst with force sufficient to cause serious injury.

OFF-SEASON STORAGE

If the machine is to be inoperative for a period longer than 30 days, prepare for storage as follows.

1. Clean the engine and the entire unit thoroughly.
2. Lubricate all lubrication points. Wipe the entire machine with an oiled rag to protect the surfaces.
3. Refer to the engine manual for correct engine storage instructions. The engine must be completely drained of fuel to prevent gum deposits from forming on essential carburetor parts, fuel lines and fuel tanks.
4. Refer to battery storage instructions in previous column.
5. Store unit in a clean, dry area.

NOTE

When storing any type of power equipment in an unventilated or metal storage shed, care should be taken to rustproof the equipment. Using a light oil or silicone, coat the equipment, especially any chains, springs, bearings and cables.

TROUBLE SHOOTING CHART FOR ELECTRIC START MODELS

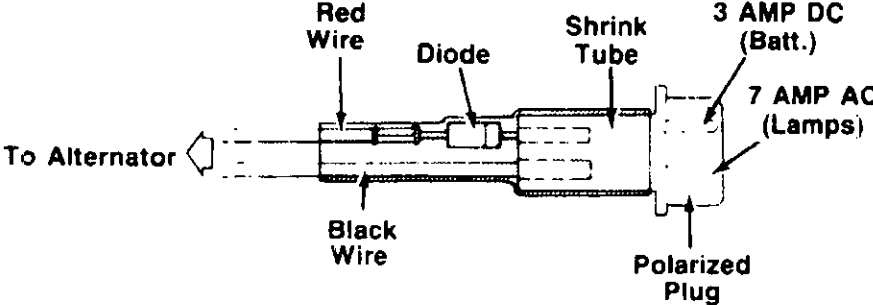
TROUBLE	LOOK FOR	REMEDY
Engine will not crank	Battery installed incorrectly	The battery must be installed with the negative terminal, identified at the terminal post by (Neg, N or -), grounded. The positive terminal (Pos, P or +) attaches to the large cable from the solenoid. The small red wire from the fuse holder or circuit breaker is also attached to the positive terminal.
	Blown fuse or circuit breaker	Replace fuse with 7½ amp fuse ¼ x 1¼" lg. Circuit breaker will reset itself when it cools off. Fuses or circuit breakers seldom open or fail without a reason. The problem must be corrected. Check for loose connections in the fuse holder. Replace fuse holder if necessary. A dead short may be in the cranking or charging circuit where the insulation may have rubbed through and exposed the bare wire. Replace the wire or repair with electrician's tape if the wire strands have not been damaged. Note: Look for a wire pinched between body panels, burned by the exhaust pipe or muffler or rubbed against a moving part.
Battery is dead or weak		Use a hydrometer to check the condition of the battery. The Specific Gravity (s.g.) should be 1.265 at 80°F. (1.215 s.g. minimum needed for cranking engine). The reason for the battery failing must be determined. (1) Defective battery. Battery will not accept or hold a full charge. (2) Short circuit. Check for grounded wire. (3) Charging system not working. The charging system is an alternator located under the flywheel. It is unregulated and rated 3 amp. at 3500 r.p.m. A diode (rectifier) is located in the output lead just before the wire harness plug on the engine side.
		
Mechanical failure (Wires and switches)		The diode changes A.C. to D.C. to charge the battery. A bad diode can either fail to charge the battery or discharge the battery if the alternator is shorted as well as the diode. To test: (1) Disconnect charger lead from the battery (small red wire). (2) Connect 12 V small test lamp between the 3 amp. D.C. charge lead and the positive terminal of the battery. (3) With the engine off, the lamp should not light. If it does, the diode and possibly the alternator should be replaced. (4) Start the engine. The lamp should light. If it does not, the alternator (stator) or lead wire is bad and should be replaced.
		The interlock system includes two mechanical activated switches which are wired in series in the circuit used to energize the starter solenoid. While testing the interlock system, you will make the mower temporarily unsafe by permitting the engine to be started with the blade and clutch engaged. WARNING: While testing, disengage the clutch, shut off the blade control, set the parking brake and place the gear shift lever in neutral. Attach a wire (minimum 18 gauge) to the positive terminal of the battery and touch the other end to the small terminal on the solenoid. If the engine does not crank: (1) There is a loose connection or poor ground. (2) The solenoid may be bad. The solenoid can be checked by using a heavy wire (#8 gauge minimum) and jumping between the two large terminals. If the engine cranks, the solenoid is bad. (3) If the engine does not crank when you jump the solenoid, have the starter motor tested by an authorized engine dealer. If the engine does crank, the problem is with one of the safety switches, ignition switch or the wire between the fuse holder (or circuit breaker) and the small terminal on the solenoid. Note: Look for a poor connection at the switches or a defective switch. Replace if necessary.
Engine cranks but will not start	Throttle or choke not in starting position	Check owner's guide for correct position for throttle control and choke for starting.
	No spark to spark plug	Spark plug lead disconnected. Connect lead. Hold spark plug lead away from engine block about 1/8". Crank engine. There should be a spark. If not, have engine repaired at authorized engine service dealer. Faulty spark plug. To test, remove spark plug. Attach spark plug lead to spark plug. Ground the spark plug body against the engine block. Crank the engine. The spark plug should fire at the electrode. Replace if it does not.

TROUBLE SHOOTING CHART FOR ELECTRIC START MODELS

TROUBLE	LOOK FOR	REMEDY
	No fuel to the carburetor	Gasoline tank empty. Fill. Fuel line or in-line fuel filter plugged. Remove and clean fuel line. Replace filter if necessary.
	Air filter dirty	If the air cleaner is dirty, the engine may not start. Clean or replace as recommended by the engine manufacturer.
Engine smokes	Engine loses crankcase vacuum	Dipstick not seated or broken. Replace defective part. Engine breather defective. Replace.
Excessive vibration	Bent or damaged blade spindle	Stop engine immediately. Check all pulleys, blade adapters, keys and bolts for tightness and damage. Tighten or replace any damaged parts.
	Bent blade	Stop engine immediately. Replace damaged blade. Only use original equipment blades
Mower will not discharge grass or leaves uncut strips	Engine speed low Transmission selection Blades short or dull	Throttle must be set between 3/4 and full throttle. Use lower transmission speed. The slower your ground speed, the better the quality of cut. Sharpen or replace blades (uncut strip problem only). Make certain deck engagement adjustment is correct. Refer to page 15.

TMO-33919B

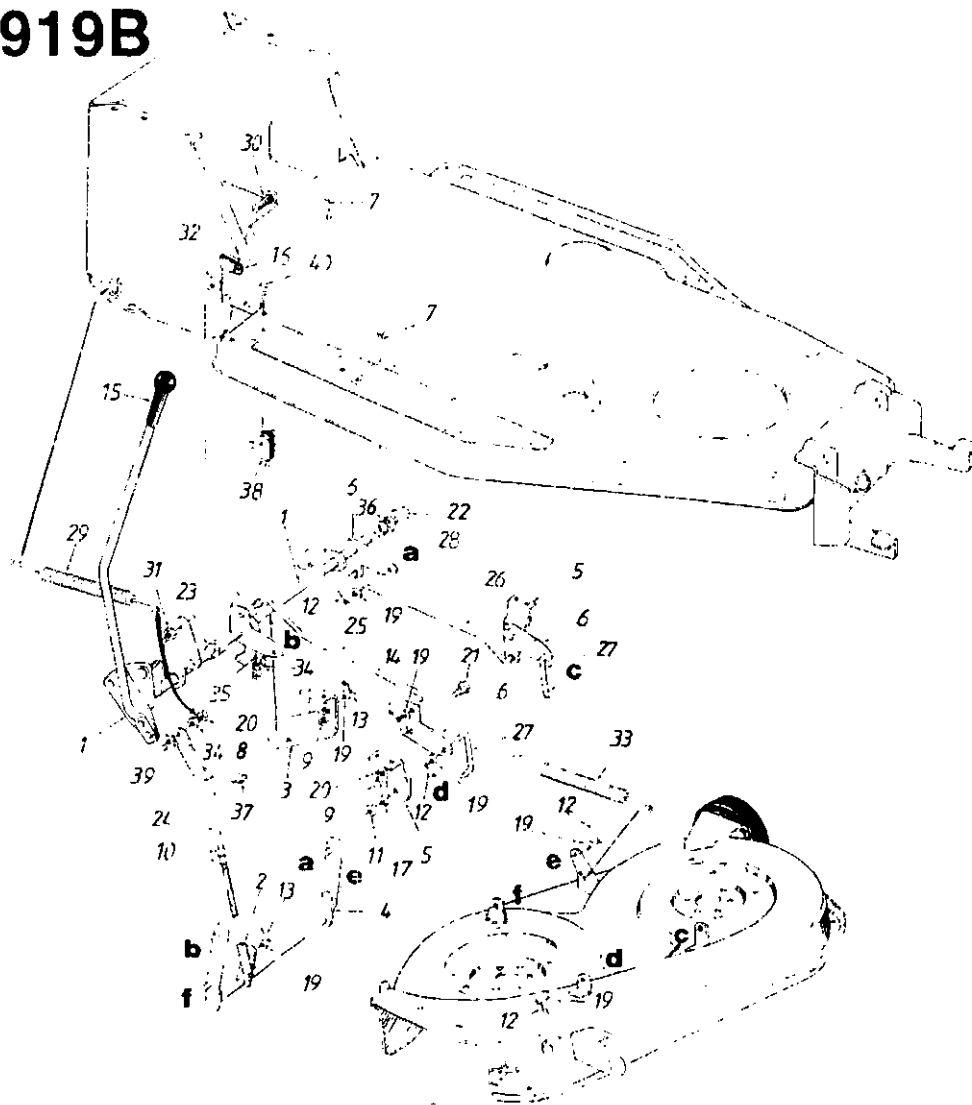

**12 H.P. 32" LAWN TRACTOR
PARTS LIST FOR MODEL TMO-33919B**

REF. NO.	PART NO.	DESCRIPTION	NEW PART	REF. NO.	PART NO.	DESCRIPTION	NEW PART
1	16661	Lift Shaft Ass'y.		22	741-0225	Hex Flange Brg.	
2	16682	Pivot Sleeve Ass'y.		23	741-0495	Nyliner Flanged Brg.	
3	16683	Deck Lock Out Brkt.		24	747-0677	J-Bolt 3/8-16 x 5.25" Lg.	
4	16688	Stabilizer Ass'y		25	747-0678	Connecting Rod—R.H.	
5	16692	Deck Lift Hanger		26	747-0679	Connecting Rod—L.H.	
6	16698	Deck Lift Float Brkt.		27	747-0689	Lift Link	
7	710-0134	Carr. Bolt 1/4-20 x .62" Lg.		28	750-0547	Spacer	
8	712-0158	Hex L-Nut 5/16-18 Thd.		29	732-0153	Spring 8.65" Lg.	
9	712-0287	Hex Nut 1/4-20 Thd.*		30	710-0793	Ribbed Neck Bolt 3/8-24 x .80" Lg. (Special)	
10	712-0711	Hex L-Nut 3/8-24 Thd.		31	712-0241	Hex Nut 3/8-24 Thd.*	
11	712-0798	Hex Nut 3/8-16 Thd.*		32	736-0354	Fl-Wash. 3/8" I.D.	
12	714-0104	Intern. Cot-Pin 5/16" Dia.		33	732-0564	Deck Spring 10.33" Lg.	
13	714-0115	Cot-Pin 1/8" Dia.		34	712-0267	Hex Nut 5/16-18 Thd.*	
14	714-0507	Cot-Pin 3/32" Dia.		35	710-0602	Hex Wash. Hd. Tap Scr. 5/16-18 x 1.0" Lg.	
15	720-0143	Grip		36	736-0174	Spr. Wash. 625" I.D.	
16	726-0267	Clamp		37	16716	Switch Activating Brkt.	
17	736-0169	L-Wash. 3/8" I.D.*		38	725-0803	Safety Switch	
19	736-0185	Fl-Wash. .406" I.D. x .75" O.D.		39	736-0170	L-Wash. 5/16" I.D. (Special)	
20	736-0329	L-Wash. 1/4" I.D.*		40	710-0224	Hex AB-Tap Scr. #10 x .5"	
21	738-0281	Shld. Bolt .625 Dia. x .170"					

TMO-33919B

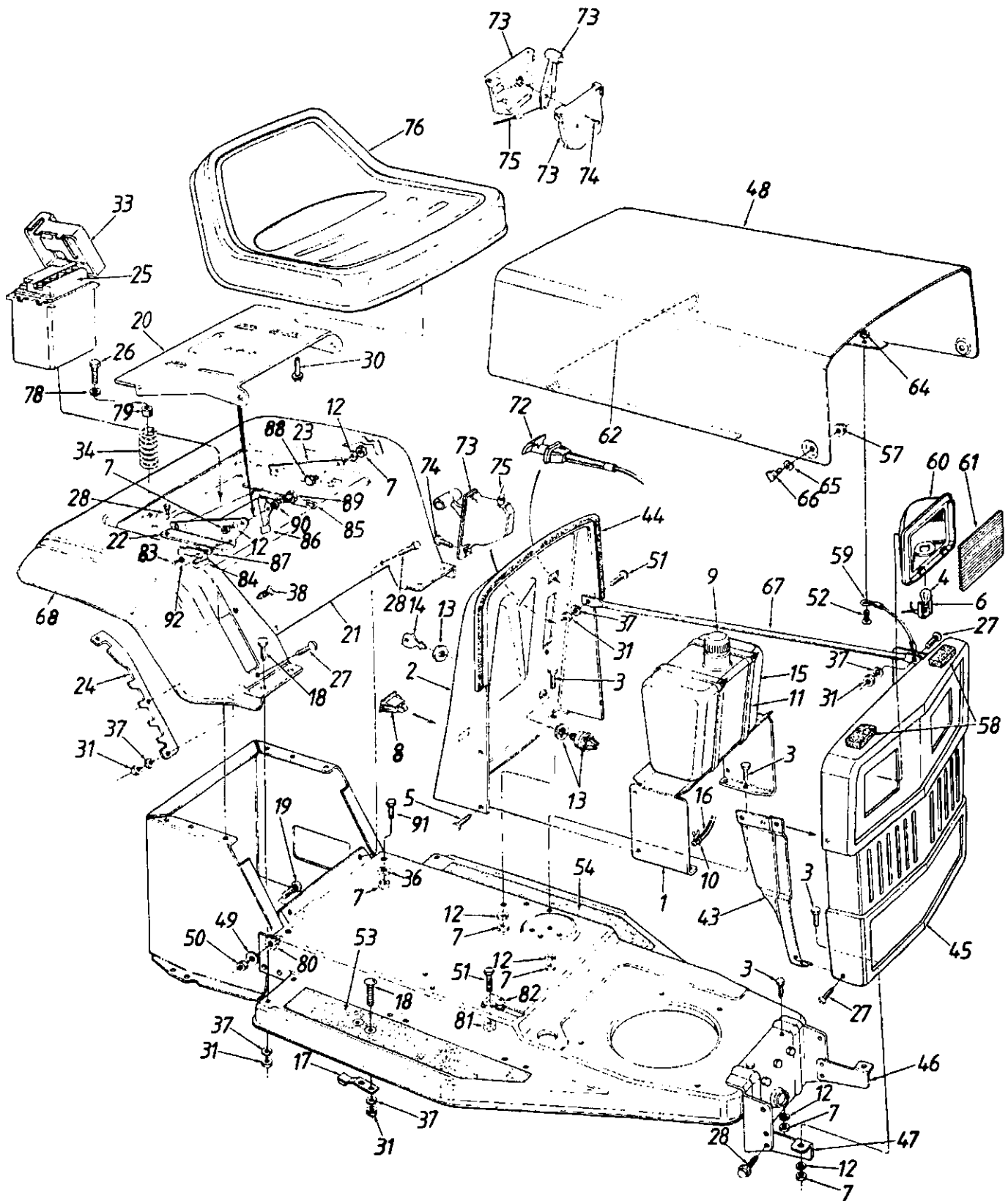

TMO-33919B

12 H.P. 32" LAWN TRACTOR PARTS LIST FOR MODEL TMO-33919B

REF. NO.	PART NO.	DESCRIPTION	NEW PART	REF. NO.	PART NO.	DESCRIPTION	NEW PART
1	16655	Dash Panel Support Brkt.		46	17143	Grille Mtg. Brkt.—L.H.	
2	16656CC621	Dash Panel		47	17144	Grille Mtg. Brkt.—R.H.	
3	710-0118	Hex Bolt 5/16-18 x 75" Lg.*		48	17146CC621	Hood	
4	725-0963	Bulb		49	736-0217	L-Wash. 3/8" I.D.—H.D.	
5	710-0776	Hex AB-Tap Scr. 1/4 x .62"		50	712-0241	Hex L-Nut 3/8-24 Thd.	
6	725-1058	Socket		51	710-0258	Hex Bolt 1/4-20 x .62" Lg.*	
7	712-0267	Hex Nut 5/16-18 Thd.*		52	710-0473	Truss Mach. Scr #10-24 x .5" Lg.	
8	725-0634	Light Switch		53	723-0308	Foot Pad—R.H.	
9	723-0333	Gas Gauge		54	723-0309	Foot Pad—L.H.	
10	726-0207	Hose Clamp		57	712-0380	Lock Nut 1/4-28 Thd.	
11	726-0209	Cable Tie		58	722-0157	Foam Strip (Optional)	
12	736-0119	L-Wash. 5/16" I.D.*		59	723-0302	Hood Stop	
13	725-0267	Ignition Switch		60	731-0705	Headlight Housing	
14	725-0201	Ignition Key		61	731-0706	Lens	
15	751-0172	Fuel Tank		62	732-0414	Hood Spring	
16	751-0173	Gas Line 24" Long		64	712-0272	Hex Sems Nut #10-24 Thd.	
17	761-0157	Blade Brake Ass'y.		65	736-0413	Spr. Wash. .39" I.D. x .62" O.D.	
18	710-0134	Carriage Bolt 1/4-20 x .62"		66	738-0724	Shld. Bolt	
19	710-0793	Ribbed Neck Bolt 3/8-24 x .8"		67	749-0722	Grille Support	
20	15607	Seat Pivot Brkt		68	731-0511	Trim Strip 81" Lg.	
21	16660CC621	Rear Fender		72	746-0617	Choke Control	
22	17284	Seat Hinge Support Brkt.—R.H.	N	73	831-0823	Throttle Control Box	
23	17283	Seat Hinge Support Brkt.—L.H.	N	74	710-0779	Truss AB-Tap Scr. #10 x .5"	
24	17133	Deck Lift Index Brkt.		75	746-0638	Throttle Wire	
25	725-0514	Battery		76	757-0345	Seat Assembly	
26	710-0602	Hex Self-Tap Screw 5/6-18 x 1" Lg.		78	736-0159	Flat Wash. .344" I.D. x .88" O.D.	
27	710-0255	Truss Mach. Scr. 1/4-20 x .75" Lg.		79	722-0160	Bushing	
28	710-0726	Hex AB-Tap Scr. 5/16 x .75" Lg.		80	726-0267	Clamp	
30	710-0623	Hex Self-Tap Scr. 3/8-16 x .75" Lg.		81	712-0107	Hex L-Nut 1/4-20 Thd.	
31	712-0287	Hex Nut 1/4-20 Thd.*		82	726-0175	Clamp	
33	731-0871	Battery Box w/Cover		83	710-0227	Hex Tap Scr. #8 x 5" Lg.	
34	732-0548	Compression Spring		84	725-1303	Spring Switch	
36	736-0242	Bell-Wash. 5/16" I.D.		85	732-0581	Ext. Spring 5.31" Lg.	N
37	736-0329	L-Wash. 1/4" I.D.*		86	17239	Seat Lift Brkt.	N
38	710-0351	Truss Wash. Hd. Tap Scr. #10 x .5" Lg.		87	726-0222	Insulator Nut Plate	
43	17175	Side Panel—R.H.		88	738-0155	Shld. Bolt .437" Dia. x .162" Lg.	
	14669	Side Panel—L.H. (Not Shown)		89	738-0296	Shld. Bolt .437" Dia. x .268" Lg.	
44	731-0511	Trim Strip 31" Lg.		90	736-0141	Spr. Wash. .445" I.D. x .75" O.D.	
45	17027	Grille		91	710-0759	Hex Bolt 5/16-18 x 5/8" Lg.*	
				92	736-0426	Fiber Washer	

*Common Hardware—May be purchased locally.
Important: **Do not** order by reference number (Ref. No.).

NOTE: Specifications subject to change without notice or obligation.

TMO-33919B

12 H.P. 32" LAWN TRACTOR PARTS LIST FOR MODEL TMO-33919B

REF. NO.	PART NO.	DESCRIPTION	NEW PART	REF. NO.	PART NO.	DESCRIPTION	NEW PART
1	14650	Front Axle Ass'y.—R.H.		27	741-0225	Hex Flange Brg. .634 Dia.	
2	16479	Front Axle Ass'y.—L.H.		28	747-0558	Tie Rod 18.37 Lg	
3	16481	Steering Arm		29	750-0532	Spacer .985 I.D.	
4	710-0152	Hex Bolt 3/8-24 x 1" Lg.*		30	750-0535	Spacer .380 I.D.	
5	710-0538	Hex Bolt 5/16-13 x .62" (Spec.)		31	16657	Front Pivot Bar Support Brkt.	
6	710-0772	Hex Bolt 5/16-24 x 2" Lg.*		32	16658	Rear Pivot Bar Support Brkt.	
7	711-0198	Ferrule		33	17127	Pivot Bar Ass'y.	
8	711-0809	Steering Drag Link		34	710-0118	Hex Bolt 5/16-18 x .75" Lg.*	
9	712-0237	Hex L-Nut 5/16-24 Thd.		35	734-1422	Front Wheel Ass'y. Comp. 13 x 6	
10	712-0241	Hex Nut 3/8-24 Thd.			734-1421	Tire Only	
11	712-0267	Hex Nut 5/16-18 Thd.*		36	734-0997	Rim Ass'y. Only	
12	712-0711	Hex Jam Nut, 3/8-24		37	734-0255	Air Valve	
13	714-0470	Cotter Pin 1/8 Dia		38	741-0487	Flange Bearing .632 I.D.	
14	717-0622	Steering Gear Segment		40	714-0111	Cotter Pin 3/32" Dia.	
15	723-3018	Drag Link Ball Joint 3/8-24 Thd.		41	736-0185	Fl-Wash. .406" I.D. x .75"	
16	726-0214	Push Cap		42	712-0237	Hex L-Nut 5/16-24 Thd.	
17	736-0119	L-Wash. 5/16" I.D.*		43	741-0501	Steering Column Brg.	
18	736-0169	L-Wash. 3/8" I.D.*		44	710-0837	Cr-Sunk Scr #10 x 5/8" Lg.	
19	736-0187	Fl-Wash. .64" I.D. x 1.24"		45	731-0805	Steering Wheel	
20	736-0343	Fl-Wash. .340" I.D. x 1.25"		46	731-0220	Steering Wheel Cap	
22	736-0271	Spr. Wash. .32 I.D. x .62"		47	731-0484	Hub Cap	
23	736-0285	Fl-Wash. .635 I.D. x 1.585		48	731-0559	Bellow Steering Column	
24	17198	Retainer Plate	N	49	736-0242	Bell-Wash. .345 I.D. x .88	
25	738-0141	Shld. Bolt .437 Dia. x .350		50	712-0798	Hex Nut 3/8-16 Thd.*	
26	738-0730	Steering Shaft		51	738-0728	Shld. Bolt 1/2" Dia. x 2.32"	

*Common Hardware—May be purchased locally.
Important: **Do not** order by reference number (Ref. No.).

Part No.	Description
788-0621	Brilliant Fire Mist Spray Paint
777-7092	Label—Side of Hood
777-7002	Plastic Logo—Side of Hood
777-6931	Labels—Frame Sides
777-5268	Steering Cap Label
777-7105	Transmatic Label
77C-6479C	Operating Manual
89-35108R	Grass Collector (Optional)

TMO-33919B

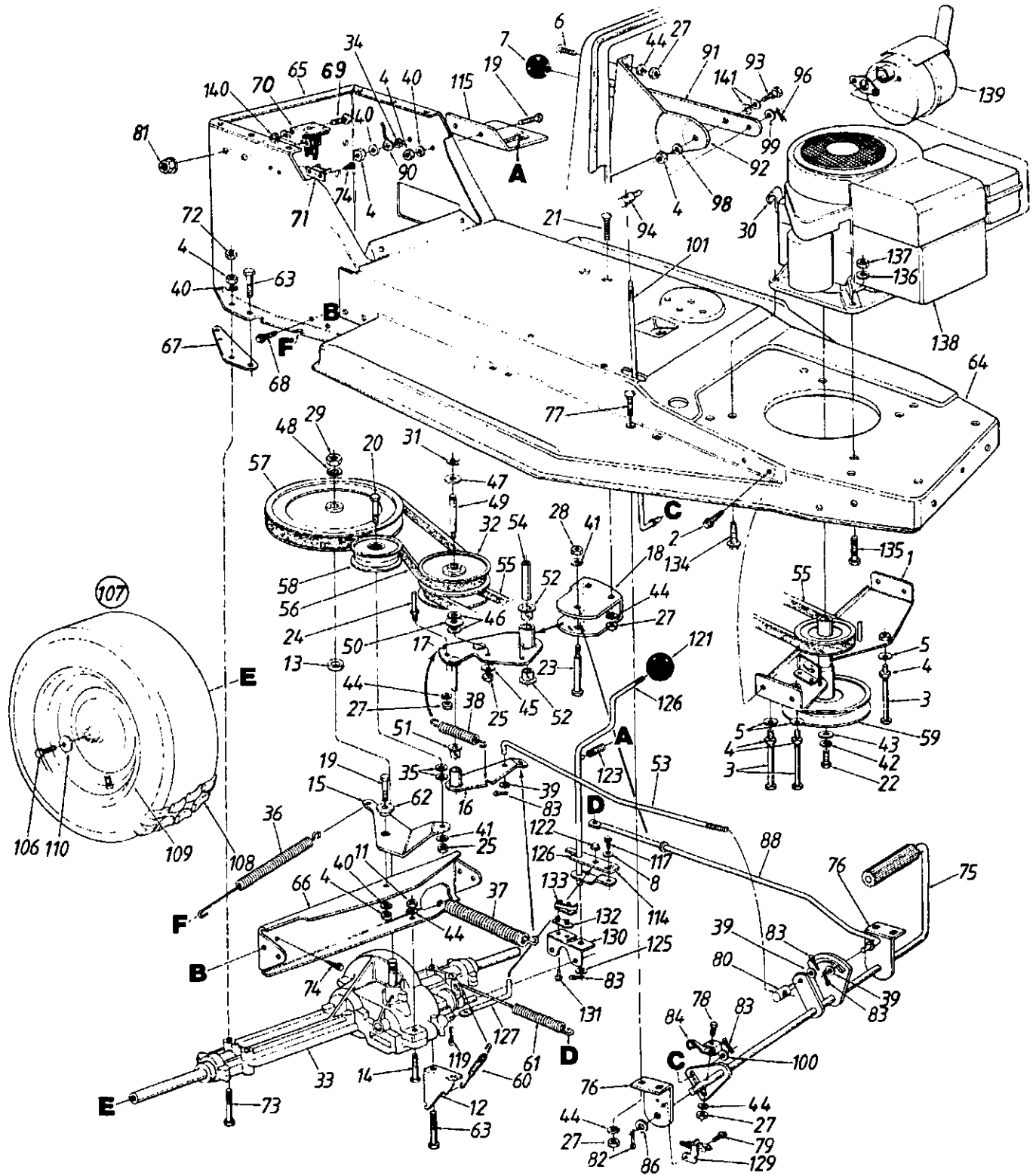

TMO-33919B

12 H.P. 32" LAWN TRACTOR PARTS LIST FOR MODEL TMO-33919B

REF. NO.	PART NO.	DESCRIPTION	NEW PART NO.	PART NO.	DESCRIPTION	NEW PART
1	16670	Engine Pulley Belt Guard Ass'y.	58	756-0437	Idler Pulley 3-1/8" Dia.	
2	710-0776	Hex AB-Tap Scr. 1/4 x .62"	59	756-0508	Dbl. Pulley 6.0" Dia. x 3.56"	
3	710-0833	Hex Bolt 5/16-18 x 5 1/4" Lg	60	732-0303	Extension Spring 3.18" Lg	
4	712-0267	Hex Nut 5/16-18 Thd.*	61	732-0413	Extension Spring 7.08" Lg.	
5	736-0242	Bell-Wash. .345" I.D. x .88	62	748-0234	Shld Spacer .500" Dia.	
6	710-0286	Truss-Mach. Scr. 1/2-20 x .50" Lg.*	63	710-0176	Hex Bolt 5/16-18 x 2.75" Lg."	
7	720-0165	Gear Shift Knob	64	16714CC621	Front Frame	N
8	736-0270	Bell-Wash. .265" I.D. x .75	65	16715CC621	Rear Frame	N
11	712-0138	Hex Nut 1/4-28 Thd.*	66	16654	Transaxle Support Brkt.	
12	17128	Spring Retainer Brkt.	67	16659	Transaxle Brkt. Reinforcement	
13	750-0721	Spacer .5" I.D.	68	710-0726	Hex Wash. AB-Tap Scr. 5/16 x .75" Lg.	
14	710-0559	Hex Bolt 1/4-28 x 1.75" Lg	69	710-0258	Hex Bolt 1/4-20 x .62" Lg.*	
15	15891	Idler Bracket	70	725-0771	Solenoid	
16	16352	Variable Speed Torque Brkt. Ass'y.	71	725-0459	Circuit Breaker	
17	16676	Variable Speed Brkt. Ass'y	72	712-0158	Hex L-Nut 5/16-18 Thd.	
18	16679	Variable Speed Pivot Brkt.	73	710-0189	Hex Bolt 5/16-18 x 3.0" Lg.*	
19	710-0118	Hex Bolt 5/16-18 x .75" Lg *	74	710-0351	Truss Mach B-Tap Scr. #10 x .50" Lg.	
20	710-0539	Hex Bolt 3/8-24 x 1 3/4" Lg Gr. 5	75	16689	Clutch/Brake Pedal Ass'y	
21	710-0703	Carr. Bolt 1/4-20 x .75" Lg.	76	16691	Clutch/Brake Pedal Mounting Brkt.	
22	710-0757	Hex Bolt 7/16-20 x 1.5" Lg *	77	710-0134	Carr Bolt 1/4-20 x .62" Lg	
23	710-0937	Hex Bolt 3/8-16 x 2.5" Lg *	78	710-0597	Hex Bolt 1/2-20 x 1.0" Lg *	
24	711-0768	Belt Guard Pin	79	710-0599	Hex TT-Tap Scr. 1/4-20 x .5"	
25	712-0241	Hex Nut 3/8-24 Thd.*	80	711-0198	Ferrule	
27	712-0287	Hex Nut 1/4-20 Thd *	81	712-0271	Hex Sems Nut 1/4-20 Thd	
28	712-0798	Hex Nut 3/8-16 Thd.*	82	714-0111	Cot-Pin 3/32" Dia. x .10" Lg.	
29	712-0922	Hex Jam Nut 1/2-20 Thd.	83	714-0507	Cot-Pin 3/32" Dia. x .75" Lg.	
30	726-0175	Clamp	84	732-0582	Switch Actuator	
31	716-0114	Snap Ring	86	736-0256	FI-Wash. .635" I.D. x 1.0"	
32	717-0800	Variable Speed Pulley Ass'y.	88	747-0686	Brake Rod	
33	717-0775	Transaxle Complete	90	725-0976	Ground Wire 7.25" Lg.	
34	736-0607	Ext. L-Wash. 5/16" I.D.	91	16663	Speed Control Lever	
35	736-0258	FI-Wash. 3/8" I.D. x 1.0" O.D.	92	16693	5 Speed Selector Brkt.	
36	732-0384	Extension Spring 6.12" Lg	93	738-0141	Shld. Bolt .437" Dia. x .35" Lg.	
37	732-0459	Extension Spring 7.5" Lg.	94	711-0677	Ferrule	
38	732-0568	Extension Spring 2.59" Lg	96	714-0104	Intern. Cot-Pin 5/16" Dia.	
39	736-0117	FI-Wash. .385" I.D. x .620"	98	736-0119	L-Wash. 5/16" I.D.*	
40	736-0119	L-Wash. 5/16" I.D.	99	736-0264	FI-Wash. .344" I.D. x .62"	
41	736-0169	L-Wash. 3/8" I.D *	100	736-0463	FI-Wash. .25" I.D. x .62" O.D.	
42	736-017	L-Wash. 7/16" I.D.*	101	747-0675	Speed Control Rod	
43	736-0322	FI-Wash. .450" I.D. x 1.25"	106	710-0627	Hex L-Bolt 5/16-24 x 75" Lg	
44	736-0329	L-Wash. 1/4" I.D *	107	734-1424	Rear Wheel Ass'y. Comp.	
45	736-033	Bell-Wash. .39" I.D. x 1.13"	108	734-1423	Turf Tread 16.0 x 7.50 Rear	
46	736-0355	FI-Wash. .56" I.D. x 1.0" O.D.	109	734-1450	Rear Wheel Rim Ass'y.	
47	736-0414	Washer "Teflon" .565 I.D.	110	736-0242	Bell-Wash. .345" I.D x .88"	
48	736-0921	L-Wash. 1/2" I.D.*	114	17178	Shift Lever Adjusting Link	N
49	738-0569	Shaft .56" Dia x 3.875" Lg.	115	16482	Shift Lever Spring Brkt.	
50	741-0405	Thrust Brg. 1.25 C.D.	117	710-0289	Hex Bolt 1/4-20 x .50 Lg.*	
51	741-0419	Flanged Nylon Brg.	119	714-0149	Intern. Cotter Pin	
52	741-0495	Nylon Flanged Brg.	121	720-0175	Ball Knob	
53	747-0688	Speed Control Link	122	726-0231	Retaining Ring	
54	750-0703	Spacer	123	732-0499	Compression Spring 1.5" Lg.	
55	754-0280	V-Belt	125	736-0226	FI-Wash. .469" I.D. x .88"	
56	754-0281	V-Belt	126	747-0694	Shift Rod Ass'y.	
57	756-0374	1/2 V-Pulley .500" D. x 8.00"	127	747-0685	Shift Rod	

TMO-33919B

12 H.P. 32" LAWN TRACTOR PARTS LIST FOR MODEL TMO-33919B (CONTINUED)

REF. NO.	PART NO.	COLOR CODE	DESCRIPTION	NEW PART	REF. NO.	PART NO.	COLOR CODE	DESCRIPTION	NEW PART
129	725-0577		Safety Switch		136	736-0119		L-Wash. 5/16" I.D.*	
130	17179		Shift Lever Support	N	137	712-0123		Hex Nut 5/16-24 Thd.*	
131	710-0227		Hex Wash. Hd. #8 x .50" Lg.		138	12 H.P.		Engine—OVM 120LT-200013	
132	726-0222		Insulator Nut Plate		139	†		Muffler	
133	725-0758		Spring Switch		140	736-0222		Ext. L-Wash. 1/4" I.D.	
134	710-0502		Hex Wash. Hd. Tap Scr. 3/8-16 x 1.25" Lg.		141	736-0141		Wave Wash. .445" I.D.	
135	710-0672		Hex Bolt 5/16-24 x 1 1/4" Lg. Grade 5						

*Common Hardware—May be purchased locally.
Important: **Do not** order by reference number (Ref. No.).

†MUFFLER CHART

Muffler	Mounting Hardware	
751-0443	Shoulder Bolt	738-0636
	Gasket	721-0208

TMO-33919B

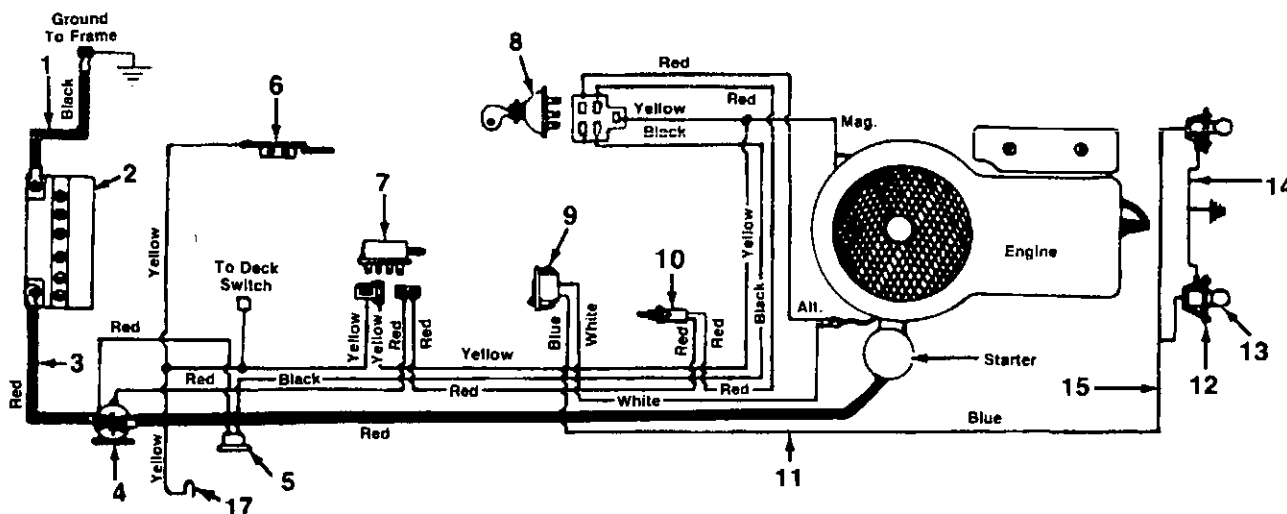

PARTS LIST FOR ELECTRICAL SYSTEM

REF. NO.	PART NO.	DESCRIPTION	NEW PART	REF. NO.	PART NO.	DESCRIPTION	NEW PART
1	725-0976	Ground Wire		9	725-0634	Light Switch	
2	725-0514	Battery		10	725-0577	Safety Switch (Black)	
3	725-0926	Electric Wire		11	725-1337	Harness	N
4	725-0771	Solenoid		12	725-1058	Socket (Sq. Headlights)	
5	725-0459	Circuit Breaker		13	725-0963	Lamp (Sq. Headlights)	
6	732-0758	Spring Switch		14	725-0916	Ground Wire	
7	725-0808	Safety Switch		15	725-1243	Headlight Harness	
8	725-0267	Key Switch		17	725-1303	Seat Switch	N

TMO-33919B

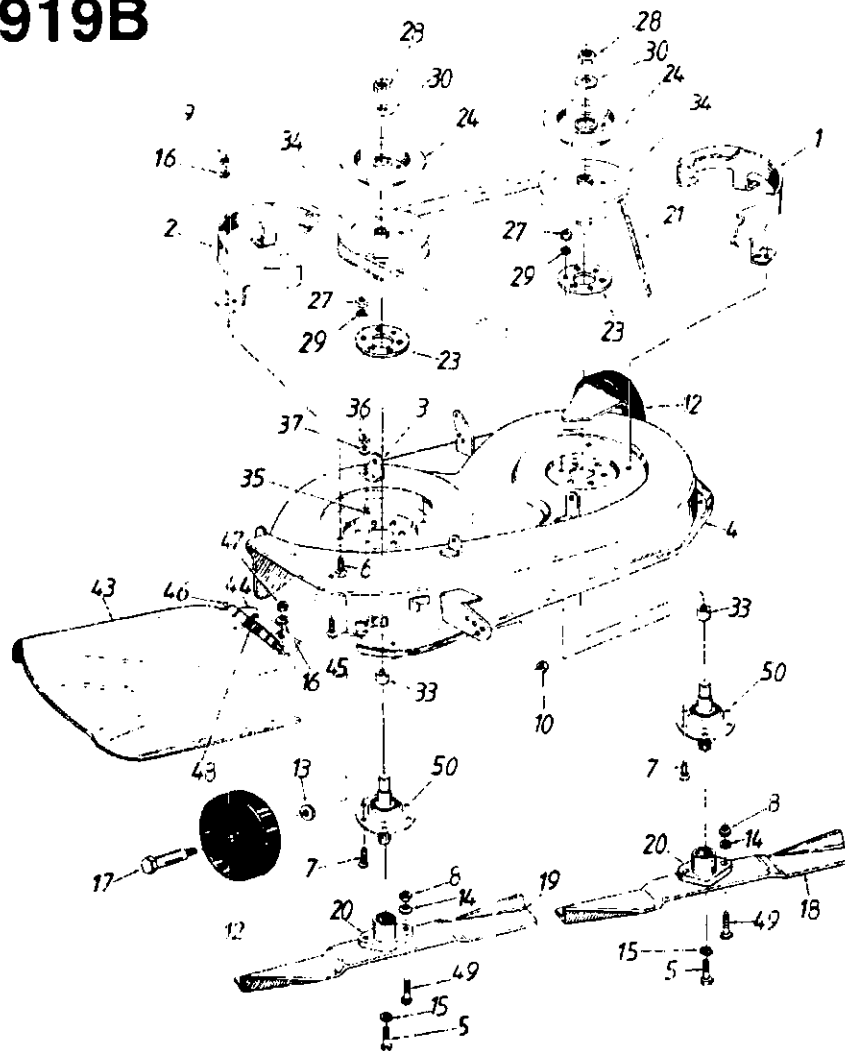

**12 H.P. 32" LAWN TRACTOR
PARTS LIST FOR MODEL TMO-33919B**

REF. NO.	PART NO.	DESCRIPTION	NEW PART	REF. NO.	PART NO.	DESCRIPTION	NEW PART
1	16607	Belt Guard Deck—L.H.		21	754-0355	V-Belt	
2	16608	Belt Guard Deck—R.H.		23	09164	Reinforcement Plate	
3	16666	Rear Deck Brkt —R.H.		24	09322	Brake Disc	
4	17101	32" Deck Ass'y.		27	712-0123	Hex Nut 5/16-24 Thd.*	
	17134	32" Deck Ass'y. Comp. (Service Only)		28	712-0318	Hex Jam Nut 5/8-18 Thd.	
5	710-0152	Hex Bolt 3/8-24 x 1.0" Lg.		29	736-0119	L-Wash. 5/16" I.D.	
6	710-0195	Hex Bolt 1/4-28 x .62" Lg.		30	736-0158	L-Wash. 5/8" I.D.	
7	710-1012	Rib Neck Bolt		33	750-0456	Spacer	
8	712-0123	Hex Nut 5/16-24 Thd.*		34	756-0486	5" Dia. Pulley	
9	712-0138	Hex Nut 1/4-28 Thc.*		35	710-0258	Hex Scr 1/4-20 x .62" Lg.*	
10	712-0181	Hex L-Nut 3/8-16 Thd.		36	712-0287	Hex Nut 1/4-20 Thd.*	
12	734-0973	Deck Wheel		37	736-0329	L-Wash. 1/4" I.D.*	
13	736-0105	Bell-Wash. .380" I.D. x .88		43	17136	Chute Ass'y.	
14	736-0119	L-Wash. 5/16" I.D.*		44	17137	Chute Bracket	
15	736-0217	L-Wash. 3/8" I.D. H.D.		45	710-0255	Truss-Mach. Scr. 1/4-20 x .75" Lg.	
16	736-0270	Bell-Wash. .265" I.D. x .75		46	711-0808	Hinge Pin	
17	738-0373	Shld. Bolt .498" Dia. x 1.53 Lg.		47	712-0298	Hex Jam Nut 1/4-20 Thd.	
18	742-0477	L.H. High-Lift Blade		48	732-0542	Torsion Spring 1.14" Lg.	
19	742-0480	R.H. High-Lift Blade		49	710-0888	Hex Bolt 5/16-24 x 1.0" Lg. (Special)	
20	748-0300	Blade Adapter		50	717-0900	Blade Spindle Complete	

TMO-33919B

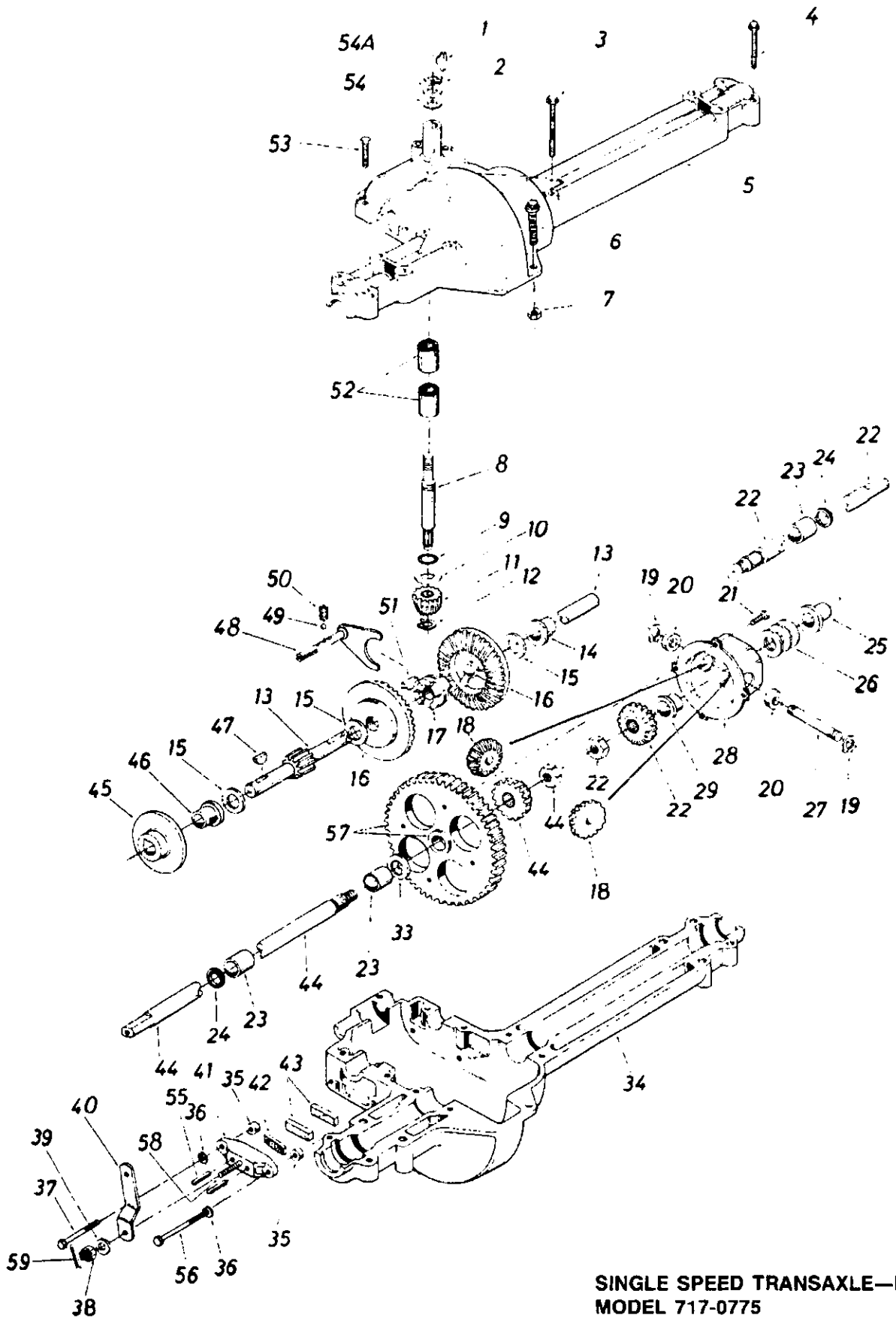

SINGLE SPEED TRANSAXLE—L.H.
MODEL 717-0775

TMO-33919B

PARTS LIST FOR SINGLE SPEED TRANSAXLE LEFT HAND 717-0775

REF. NO.	PART NO.	DESCRIPTION	NEW PART	REF. NO.	PART NO.	DESCRIPTION	NEW PART
1	714-0129	#4 Hi-Pro Key 3/32 x 5/8" Dia.		34	717-0761	Lower Housing	
2	716-0115	Snap Ring .625" Shaft		35	750-0555	Spacer .53" O.D. x 3/8" Lg.	
3	710-0854	Hex Bolt 1/4-20 x 1.75" Lg.*		36	736-0329	L-Wash. 1/4" I.D.*	
4	710-0378	Hex Bolt 5/16-18 x 2.5"		37	710-0886	Hex Bolt 1/4-20 x 1.50" Lg. (Grade 5)	
5	717-0764	Upper Housing		38	712-0335	Castle Nut 5/16-24 Thd.	
6	710-0889	Hex Fl-Bolt 1/4-20 x .38" Lg.*		39	736-0159	Fl-Wash. .344" I.D. x .875" O.D.	
7	712-0287	Hex Nut 1/4-20 Thd.*		40	717-0772	Actuating Arm	
8	717-0634	Input Shaft		41	717-0679	Brake Yoke	
9	721-0178	Square Seal 5/8" I.D.		42	717-0682	Puck Plate	
10	736-0335	Thrust Washer 5/8" I.D. x 1.25" O.D.		43	717-0678	Brake Puck	
11	717-0633	Pinion Input 14T		44	717-0765	Axle L.H. Ass'y.—Kit	
12	716-0108	Retaining Ring 7/16" Ext		45	717-0677	Brake Disc	
13	717-0768	Drive Shaft		46	741-0337	Flange Bearing 5/8" I.D. x 15/16" Lg.	
14	741-0336	Flange Brg. 5/8" I.D. x 3/4" Lg.*		47	714-0161	Woodruff Key 3/16 x 5/8 HT	
15	**	Fl-Wash. (See Below)		48	717-0754	Shift Fork Ass'y.	
16	717-0757	Bevel Gear 42T		49	741-0862	Ball Detent .250" Dia.	
17	717-0667	Clutch Collar		50	732-0863	Spring Detent	
18	717-1020	Miter Gear 15T (H.D.)		51	714-0169	#9 Hi-Pro Key 3/16" x 3/4" Dia HT	
19	716-0142	Snap Ring		52	741-0335	Needle Brg. 5/8" I.D. x 1/2" Lg.	
20	717-0690	Thrust Bearing 1/2" I.D. x 1.0" O.D.		53	710-0855	Hex Bolt 1/4-20 x 1.00" Lg.	
21	710-0862	Pan Head Scr. 1/4-20 x .50" Lg. w/Patch		54	736-0336	Fl-Wash. 5/8" I.D. x .030	
22	717-0766	Axle R.H. Ass'y.—Kit		54A	736-0337	Fl-Wash. 5/8" I.D. x .040	
23	741-0340	Sleeve Bearing 3/4" I.D. x 1.0" Lg		55	741-0343	Actuating Pir 5/16" Dia.	
24	721-0179	Oil Seal 3/4" I.D.		56	710-0966	Hex Bolt 1/4-20 x 2.50" Lg. (Grade 5)	
25	741-0339	Flange Bearing 3/4" I.D. x 15/16" Lg.		57	717-0767	Differential Gear 72T Ass'y. w/Bearing	
26	736-0188	Fl-Wash. .760" I.D. x 1.49" O.D.		58	717-0681	Sq. Hd. Bolt 5/16-24 Thd.	
27	717-0673	Cross Shaft		59	1544-013	Cotter Pin 3/32" Dia. x .50" Lg.	
28	717-0777	Differential Housing Ass'y.		—	737-0148	Grease—Shell (10 oz.)	
29	—	Part of Ref. 28					
33	736-0188	Fl-Wash. .760" I.D. x 1.49" O.D.					

**Ref. No. 15 736-0349 Fl-Wash. 5/8" I.D. x 1.0" O.D. x .020" Thk.
736-0336 Fl-Wash. 5/8" I.D. x 1.0" O.D. x .030" Thk.
736-0337 Fl-Wash. 5/8" I.D. x 1.0" O.D. x .040" Thk.





SERVICE NATIONWIDE

Montgomery Ward

**HOW TO OBTAIN
REPLACEMENT PARTS AND SERVICE**

The merchandise you have purchased from us has been carefully engineered and manufactured under Montgomery Ward's rigid quality standards and should give you satisfactory and dependable operation. However, like all mechanical merchandise, it may occasionally require adjustment, replacement parts or maintenance.

Toll Free Parts Sales Center

When you need a replacement part or accessory for a major appliance, home electronic item or lawn and garden product that is not under warranty or covered by a service contract or if you need the location of the nearest service facility, call our Parts Sales Center toll free 1-800-323-1965.

Provide the following:

1. Model, serial number and all of the other data shown on the model plate.
2. Also give the part number or numbers as shown in the parts list that came with the product.

Replacement Parts will be made available at current prices. If requested, prices will be quoted in advance when not listed.

If you order parts by mail, you will pay the transportation charges from the shipping point.

UNIT MODEL NO. _____

UNIT SERIAL NO. _____

ENGINE MODEL NO. _____

TYPE NO. _____

CODE NO. _____