

Smart choice for power

xantrex

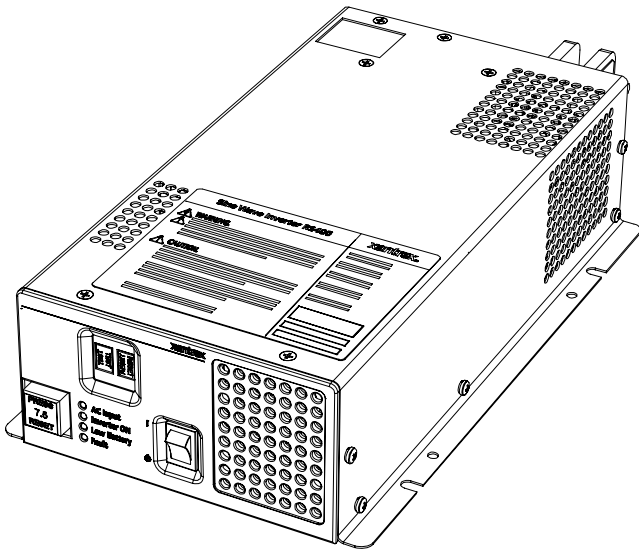

Owner's Guide

RS400 Sine Wave Inverter

www.xantrex.com

RS400 Sine Wave Inverter

Owner's Guide

About Xantrex

Xantrex Technology Inc. is a world-leading supplier of advanced power electronics and controls with products from 50 watt mobile units to one MW utility-scale systems for wind, solar, batteries, fuel cells, microturbines, and backup power applications in both grid-connected and stand-alone systems. Xantrex products include inverters, battery chargers, programmable power supplies, and variable speed drives that convert, supply, control, clean, and distribute electrical power.

Trademarks

RS400 Sine Wave Inverter is a trademark of Xantrex International. Xantrex is a registered trademark of Xantrex International.

Other trademarks, registered trademarks, and product names are the property of their respective owners and are used herein for identification purposes only.

Notice of Copyright

RS400 Sine Wave Inverter Owner's Guide© January 2007 Xantrex International. All rights reserved.

Disclaimer

UNLESS SPECIFICALLY AGREED TO IN WRITING, XANTREX TECHNOLOGY INC. ("XANTREX")

(a) MAKES NO WARRANTY AS TO THE ACCURACY, SUFFICIENCY OR SUITABILITY OF ANY TECHNICAL OR OTHER INFORMATION PROVIDED IN ITS MANUALS OR OTHER DOCUMENTATION.

(b) ASSUMES NO RESPONSIBILITY OR LIABILITY FOR LOSS OR DAMAGE, WHETHER DIRECT, INDIRECT, CONSEQUENTIAL OR INCIDENTAL, WHICH MIGHT ARISE OUT OF THE USE OF SUCH INFORMATION. THE USE OF ANY SUCH INFORMATION WILL BE ENTIRELY AT THE USER'S RISK.

Date and Revision

January 2007, Revision A

Part Number

445-0167-01-01

Contact Information

Telephone: 1-800-670-0707 (toll free in North America)

1-604-422-2777 (direct)

Fax: 1-604-420-2145

Email: CustomerService@xantrex.com

Web: www.xantrex.com

About This Guide

Purpose

The <product name><document type> contains information for the coach owner to operate and troubleshoot the RS400 Sine Wave Inverter (RS400).

Scope

The Owner's Guide provides safety guidelines, operation, troubleshooting, and warranty information for the RS400 Sine Wave Inverter.

The guide does not provide detailed information about batteries and battery maintenance. You will need to consult the battery manufacturer's guide for this information.

Organization

This guide is organized into three chapters, one appendix, and a warranty:

Chapter 1, "Introduction", outlines the main performance and safety features of the RS400. Reading this chapter will give you a clear understanding of the inverter's capabilities.

Chapter 2, "Operation", provides information about turning the inverter on and operating the unit. Details are provided on how to read the front panel indicators to monitor the RS400.

Chapter 3, "Troubleshooting", explains how to identify and solve problems that can occur with the RS400.

Appendix A, "Specifications", provides the electrical and physical specifications of the RS400.

"Warranty and Product Information", contains the product's warranty, explains how to return a product for service, and describes how to prepare for a call to Xantrex Customer Service.

Conventions Used

The following conventions are used in this guide:



WARNING

Warnings identify conditions that could result in personal injury or loss of life.



CAUTION

Cautions identify conditions or practices that could result in damage to the RS400 Sine Wave Inverter or to other equipment.

Note: Notes describe additional information which may add to your understanding of how to use the RS400 Sine Wave Inverter.

Important: These notes describe an important action item or an item that you must pay attention to.

Acronyms and Terminology

AC	Alternating current
DC	Direct current
CSA	Canadian Standards Association
FCC	Federal Communications Commission
GFCI	Ground fault circuit interrupter
UL	Underwriters Laboratories Inc.
Shore power	refers to the AC input power from a utility grid, generator, or other external AC source.

Related Information

You can find more information about Xantrex Technology Inc. as well as its products and services at www.xantrex.com

Important Safety Instructions



WARNING

This Owner's Guide contains important safety and operating instructions.

Before using your RS400 Sine Wave Inverter, be sure to read, understand, and save these safety instructions.



WARNING: Restrictions on use

The RS400 Sine Wave Inverter shall not be used in connection with life support systems or other medical equipment or devices.



WARNING: Shock hazard

The RS400 has On/Standby mode only. It does not have an Off mode, that is, DC power is permanently connected to the unit.

General Precautions

1. Before installing and using the inverter, read all appropriate sections of this guide and any cautionary markings on the inverter and the batteries.
2. Do not operate the inverter if it has received a sharp blow, been dropped, or otherwise damaged. If the unit is damaged, see "Warranty and Product Information" on page WA-1.
3. Do not dismantle the inverter; it contains no user serviceable parts. Attempting to service the unit yourself could cause electrical shock or fire. **Internal capacitors remain charged after all power is disconnected.** See "Warranty" on page WA-1 for instructions on obtaining service.

4. To reduce the risk of electrical shock, disconnect both AC and DC power from the inverter before working on any circuits connected to the inverter. Turning the On/Standby switch to Standby (⊕) will not reduce this risk.
5. Protect the inverter from rain, snow, spray, and water.
6. To reduce the risk of overheating, keep the ventilation openings clear, and do not install the inverter in a compartment with limited airflow.

Explosive Gas Precautions

1. Batteries generate explosive gases during normal operation. Be sure you follow all relevant instructions exactly before installing or using your inverter.
2. This equipment contains components which tend to produce arcs or sparks. To prevent fire or explosion, do not install the inverter in compartments containing batteries or flammable materials or in locations that require ignition-protected equipment. This includes any space containing gasoline-powered machinery, fuel tanks, as well as joints, fittings, or other connections between components of the fuel system.

FCC Information to the User

This Class B device complies with Part 15 of the FCC Rules and all requirements of the Canadian Interference-Causing Equipment Regulations. Operation is subject to the following two conditions: (1) this device may not cause harmful interference, and (2) this device must accept any interference received, including interference that may cause undesired operation.

Contents

Important Safety Instructions

General Precautions	v
Explosive Gas Precautions	vi
FCC Information to the User	vi

1 Introduction

How RS400 Works	1-2
Premium Power and Ease of Use	1-2
Comprehensive Protection	1-3
RS400 Features	1-4
Front Panel	1-4
Back Panel	1-5
Optional Accessory: Remote Switch	1-6
Dimensions of Remote Switch	1-6
Part number of Remote Switch	1-6

2 Operation

Front Panel Features	2-2
Operating the RS400	2-3
Turning the RS400 to On or to Standby	2-3
Turning the RS400 to Standby When Not in Use	2-3
Using the S400 Remote Switch	2-4
Operating in Invert Mode	2-5
Recharging Your Batteries When Low Battery Light Illuminates	2-5
Recovering from Low Battery Voltage Shutdown	2-6
Restarting or Operating Multiple Appliances	2-6
Operating in Shore Power Mode	2-7
Monitoring the Indicator Lights	2-8
Resetting After a Fault or Shutdown	2-9

3 Troubleshooting

Troubleshooting Reference	3-2
---------------------------	-----

A Specifications

Electrical Specifications -----A-2
Physical Specifications with Projections -----A-2
Regulatory Approvals-----A-3
Fan Cooling System -----A-3
Transfer Circuit -----A-3

Warranty and Product Information ----- WA-1

Warranty ----- WA-1
Return Material Authorization Policy ----- WA-3
Out of Warranty Service ----- WA-3
Information About Your System----- WA-4

Index ----- IX-1

1

Introduction

Congratulations on your purchase of the RS400 Sine Wave Inverter!

The RS400 has been designed to give you premium power, ease of use, and outstanding reliability.

Please read this chapter to familiarize yourself with the main performance and protection features of the RS400.

To ensure quality customer service for your inverter, be sure to keep your proof of purchase. Also, take a few minutes at this time to complete the form, “Information About Your System” on page WA-4.

How RS400 Works

RS400 is a sine wave inverter which converts 12 volts direct current (DC) power from your battery to 120 volts alternating current (AC) power. This AC power is the same as the electricity you get from your utility. In terms of output, RS400 provides 400 watts of sine wave power for operating your appliances.

Premium Power and Ease of Use

RS400 provides premium power for your entertainment system. The inverter's sine wave output provides clean power for your TV, VCR, DVD, satellite receiver, and stereo.

Superior features and rugged durability have been combined with ease of use:

- 400 watt inverter with 800 watt surge provides sufficient power for two entertainment systems
- Filtered sine wave output will not cause distortion on sensitive entertainment electronics
- Built-in transfer switch automatically transfers between inverter power and incoming AC power
- DSP control technology starts complex loads with ease
- Two AC outlets and hardwire AC connections
- Easy-to-read indicator lights on the front panel
- Automatic cooling fan

Comprehensive Protection

RS400 is designed to meet UL 458 and CSA C22.2 No. 107.1 safety standards and it is compliant with FCC Class B.

RS400 comes equipped with numerous protection features to guarantee you safe and worry-free operation.

Protection feature	This protection feature...
Low voltage indication and shutdown	Protects the battery from becoming completely discharged. The Low Battery light indicates that input voltage is low (10.5 volts). If the input voltage drops below 10.0 volts the RS400 shuts down automatically and the Inverter ON light turns off. The RS400 recovers automatically when the input voltage comes up to about 12.6 volts.
High voltage shutdown	Protects the RS400 by disabling the AC output when the input voltage rises to 15.3 volts or more. The AC output is enabled when the input voltage drops to 14.5 volts.
Over-temperature shutdown	Disables the AC output of the RS400 when the internal temperature rises to unacceptable levels due to higher ambient temperature or overloading. The RS400 recovers automatically when it cools down.
Overload protection	Disables the AC output of the RS400 if the appliance connected to the inverter exceeds the 400 watt rating of the inverter. The RS400 will have to be reset. (See “Resetting After a Fault or Shutdown” on page 2–9.)
Supplemental circuit protection	Trips and disables the AC output when a current in excess of 7.5 amps is drawn from the RS400. The supplemental circuit protector can be reset to enable the unit to operate again after clearing the overload condition. (See “Resetting After a Fault or Shutdown” on page 2–9.)
Short circuit protection	Disables the AC output of the RS400 when a short circuit is applied on the AC output. Once the short circuit is cleared, the RS400 will have to be reset. (See “Resetting After a Fault or Shutdown” on page 2–9.)
Ground fault circuit interrupter (GFCI)	Trips and disables the output of the RS400 when a ground fault current is detected. The output can be enabled again by resetting the GFCI, once the ground fault is cleared. (See “Ground Fault” on page 2–9.)

RS400 Features

Front Panel

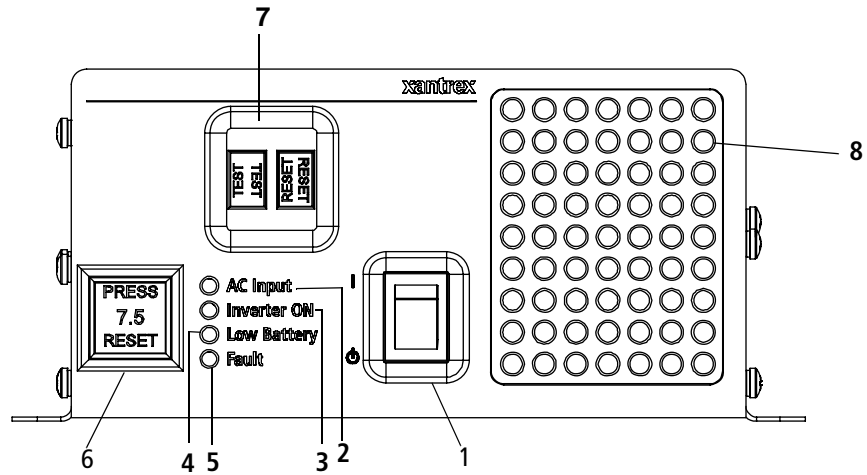

Figure 1-1 Front panel of the RS400

Table 1-1 Front Panel Features

Feature	Description
1	On/Standby Switch turns the inverter to On (I) or to Standby (⏻).
2	AC Input light illuminates when you are connected to shore power. (Shore power refers to the AC input power from a utility grid, generator or external AC source.)
3	Inverter ON light illuminates only when the RS400 is operating in invert mode.
4	Low Battery light illuminates when your battery voltage is lower than 10.7 volts.
5	Fault light illuminates for fault conditions such as over temperature, output overload, or battery over voltage.
6	Supplemental Circuit Protection button trips if there is an over-current (over 7.5 amps) or a short circuit.
7	GFCI opening enables Reset and Test monthly capability.
8	Ventilation openings provide air circulation for peak performance.

Back Panel

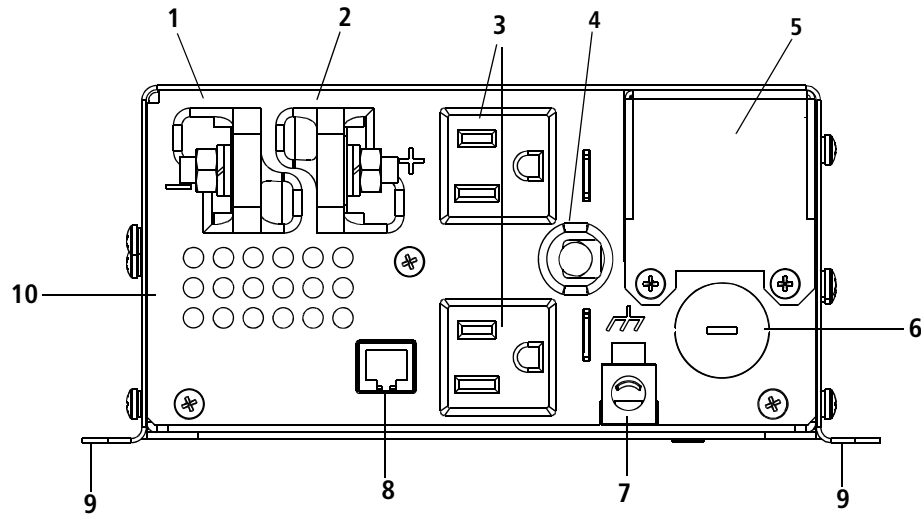

Figure 1-2 Back panel of the RS400

Table 1-2 Back Panel Features

Feature	Description
1	DC terminal, negative
2	DC terminal, positive
3	Two AC outlets
4	AC input cord for shore power
5	Wiring box access panel
6	AC knockout (output) for hardwiring
7	Chassis ground lug
8	Remote switch jack
9	Mounting flanges
10	Ventilation openings provide air circulation.

Optional Accessory: Remote Switch

An optional remote switch can be plugged into the remote switch jack at the back of the RS400. It lets you switch the RS400 from on to standby from a convenient location—up to 25 feet (7.5 m) away from the inverter (using the cable supplied with the switch).

Dimensions of Remote Switch

Height	2.5 inches (63.5 mm)
Width	2 inches (50.8 mm)
Depth	1.1 inches (28.3 mm)
Cable length	25 feet (7.5 m)

Part number of Remote Switch

To purchase a remote switch, please contact Customer Service for a referral to a distributor. Please provide the part number 808-2400. See page ii for contact information.

Instructions for installing and using the remote switch are included in the remote switch package and the RS400 Sine Wave Inverter Installation Guide.

Note: The remote switch jack at the back of the RS400 may not be accessible once the inverter has been mounted.

If you intend to use the remote switch with an RS400 that has already been installed, consult a qualified service technician before installing and connecting the remote switch.

2

Operation

Chapter 2, “Operation”, explains how to use your RS400 effectively. This chapter explains how to turn the RS400 to On (I) or Standby (ϕ) from the front panel or from the S400 Remote Switch, monitor the status of the RS400, and reset the inverter.



CAUTION

Read this chapter before operating the RS400 Sine Wave Inverter.



WARNING: Restrictions on use

The RS400 Sine Wave Inverter shall not be used in connection with life support systems or other medical equipment or devices.

Front Panel Features

Before you begin to operate the RS400, review the front panel features in Figure 2-1.

For a detailed description of each of the different features, see Figure 1-1, “Front panel of the RS400” on page 1-4 in the Introduction chapter.

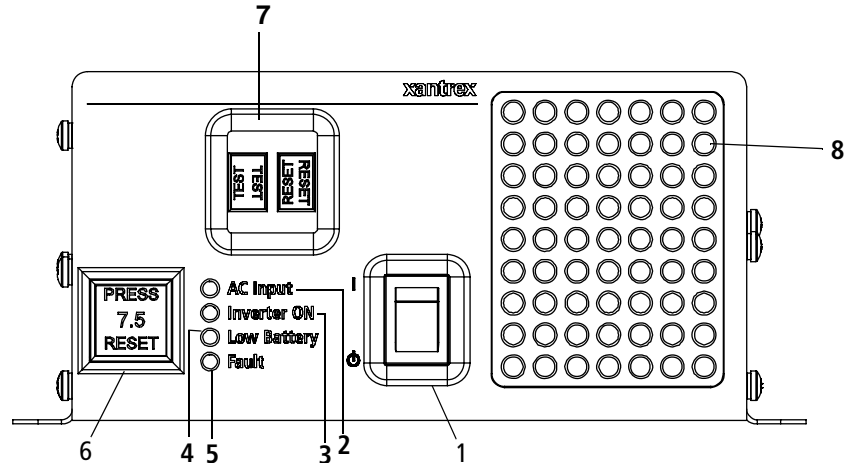

Figure 2-1 Front panel of the RS400

Table 2-1 Front panel features

Feature	Description
1	On/Standby switch
2	AC Input light
3	Inverter ON light
4	Low Battery light
5	Fault light
6	Supplemental Circuit Protection button
7	GFCI
8	Ventilation openings

Operating the RS400

	The RS400 operates in either invert mode or shore power mode.
Invert mode	In invert mode, the RS400 powers your appliances using energy from the battery (DC power). See “Operating in Invert Mode” on page 2–5.
Shore power mode	In shore power mode, the RS400 is connected to shore power and your appliances are powered from the AC input power. See “Operating in Shore Power Mode” on page 2–7.
	Shore power (pass-through) refers to the AC input power from a utility grid, generator or external AC source.

Turning the RS400 to On or to Standby



WARNING: Shock hazard

When the On/Standby switch is in the Standby (⏻) position with the RS400 connected to shore power, AC voltage will be present at the output of the inverter.

The On/Standby switch on the RS400 turns the inverter to On (⏻) or to Standby (⏻) when operating in invert mode.

If you have installed the S400 Remote Switch, you can also use the remote switch to turn the RS400 to On (⏻) or to Standby (⏻). See “Using the S400 Remote Switch” on page 2–4.

The On/Standby switch on the RS400 or the S400 Remote Switch is also used to reset the inverter after a Fault condition. See “Resetting After a Fault or Shutdown” on page 2–9.

Important: The RS400 operates normally without the S400 Remote Switch installed.

Turning the RS400 to Standby When Not in Use

If you won't be using the RS400 for an extended period of time, turn the inverter's On/Standby switch to the Standby (⏻) position. Turning the switch to Standby ensures that the RS400 will draw no current from the battery.

If you are disconnected from shore power with the RS400 On/Standby switch in the On (⏻) position and the optional S400 Remote Switch in the Standby (⏻) position, the RS400 draws very little current (about 1 mA) from the battery.

Using the S400 Remote Switch

The S400 Remote Switch performs the same function as the On/Standby switch on the RS400.

Invert mode use only The S400 Remote Switch provides On/Standby control only when the RS400 is operating in invert mode.

To use the S400 Remote Switch, the On/Standby switch on the RS400 must be turned to the On (I) position. See “Operating in Invert Mode” on page 2–5.

Important: When shore power is present, the S400 Remote Switch will not change the operation of the inverter.

Purpose The S400 Remote Switch provides remote control of the RS400 from a convenient location up to 25 feet (7.5 meters) away using the supplied telephone cable.

Cable length You can use a longer cable up to a maximum recommended length of 50 feet (15 meters). Xantrex recommends using a high quality 4-wire telephone cable with 6-position, 4-contact connectors.

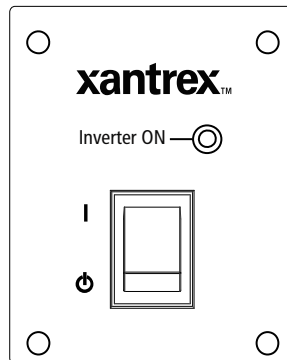

Figure 2-2 S400 Remote Switch

Operating in Invert Mode

In invert mode, the RS400 powers your appliances using energy from the battery. If the On/Standby switch on both the RS400 and the optional S400 Remote Switch are turned to On (I), the RS400 automatically supplies your appliances with inverter power if the shore power source fails or becomes disconnected.

To operate the RS400 in invert mode:

1. Disconnect the RS400 from shore power.
2. Turn the On/Standby switch on the RS400 to the On (I) position.

The RS400 Inverter ON light illuminates.

AND

If you have an optional S400 Remote Switch installed, turn the remote switch to On (I).

The Inverter ON light illuminates on the S400 Remote Switch.

3. Operate your appliances.

Important: The RS400 operates normally without the S400 Remote Switch installed.

If you are not using the RS400, see “Turning the RS400 to Standby When Not in Use” on page 2–3.

Recharging Your Batteries When Low Battery Light Illuminates

Low battery

If the Low Battery light illuminates on the RS400 while it is operating, your battery level is low (less than 10.7 volts). As long as the Inverter ON light is illuminated on the RS400, the unit will continue to supply inverter power to your appliances.

However, Xantrex highly recommends that you recharge your batteries. Turn off your appliances and recharge your battery. When the Low Battery light turns off (at 12.6 volts), you can restart your appliances. See “Restarting or Operating Multiple Appliances”.

Importance of recharging

Xantrex recommends that you recharge your batteries before they are 50% discharged. This gives them a much longer life cycle than recharging them when they are almost completely discharged.

More information

For more information about battery chargers and battery monitors, see the Xantrex web site at www.xantrex.com

Recovering from Low Battery Voltage Shutdown

If the Low Battery light illuminates and the Inverter ON light turns off on the front panel when you are operating the unit, the RS400 has shut down due to low battery voltage (10.3 volts). Output power is interrupted.

To recover from a low battery voltage shutdown:

1. Turn off your appliances.
2. Connect the unit to an AC source to switch to shore power mode (see “Operating in Shore Power Mode” on page 2–7).
3. Restart your appliances while in shore power mode.

Note: If you want to switch to inverter mode right after a low battery voltage shutdown, you have to start recharging the battery with a separate charger even in shore power mode. The moment you do step 2, the unit automatically resets the low battery voltage shutdown. So if you start recharging the battery and shore power is suddenly disconnected, the unit can still operate in inverter mode until a low battery voltage condition occurs again.

Restarting or Operating Multiple Appliances

The RS400 can handle several appliances simultaneously as long as they do not draw more than 400 watts in total.

To restart or operate several appliances:

- ◆ Turn each appliance on separately after the RS400 has started.
This action ensures that the RS400 does not have to deliver the starting current for all the loads at once and will help to prevent an overload shutdown.

Operating in Shore Power Mode

Definition	Shore power (pass-through) refers to the AC input power from a utility grid, generator, or external AC source.
Shore power mode	In shore power mode, the RS400 is connected to shore power and your appliances are powered from the AC input power.
Transfer to invert mode	The transfer to inverter power will occur if shore power is present, but either the shore power voltage is too low (less than 85 volts AC) or too high (greater than 140 volts AC). In this case, the transfer from shore power to inverter power prevents damage to your appliances.
S400 Remote Switch	You cannot use the optional S400 Remote Switch to control the RS400 when it is operating in shore power mode.

Important: The RS400 transfers the appliances to shore power whenever shore power is connected, regardless of the position of the On/Standby switches.

To operate in shore power mode:

1. Connect the RS400 to shore power.
The AC Input light on the RS400 illuminates. The On/Standby switch on both the S400 Remote Switch and the RS400 can be either On (I) or in Standby (⊕) position.
2. Operate your appliances.

Monitoring the Indicator Lights

The four indicator lights on the front panel show you the operating status of the RS400. See Table 2-2.

For an illustration of the indicator lights on the front panel, see “Front panel of the RS400” on page 2–2.

If none of the front panel lights are on, see “Troubleshooting Reference” on page 3–2.

Table 2-2 Status of Indicator Lights

Light	Color	Status	Action
AC Input	Green	When the RS400 is connected to shore power, the AC Input light illuminates.	You can run all your appliances from shore power.
Inverter ON	Green	When the RS400 is on, the Inverter ON light illuminates.	You can run your appliances using energy from the battery.
Low Battery & Inverter ON	Yellow & Green	When both lights illuminate, your battery level is low. (The battery voltage has dropped below 10.7 volts DC.)	You can run appliances, but your battery level is low. Charge your battery or connect to shore power.
Low Battery	Yellow	When the Low Battery light illuminates, your battery level is critically low. (The battery voltage has dropped below 10.3 volts DC.)	You cannot run appliances. Charge your battery or connect to shore power.
Fault	Red	The Fault light illuminates whenever there is a battery over-voltage fault condition (exceeds 15.3 volts), output overload fault condition or over-temperature fault condition.	You cannot run appliances as the AC output is disabled in invert mode. Clear the fault condition. Reset the RS400 by turning the On/Standby switch on the RS400 or the optional S400 Remote Switch to Standby (⏻) and then to On (⏻), or connect to shore power.

Resetting After a Fault or Shutdown

This section provides explanations and procedures for resetting the RS400 after a fault or shutdown.

If you are unable to resolve the problem after referring to Table 2-3, refer to the “Troubleshooting” section on page 3–2.

Table 2-3 Resetting After a Fault or Shutdown

Feature	Status	Action
Shutdown	The RS400 needs to be reset.	Turn the On/Standby switch on either the inverter’s front panel or the optional S400 Remote Switch to Standby (⏻) and then to On (⏻).
Short Circuit	If there is a short circuit, the Supplemental Circuit Protection button trips.	Remove the short circuit condition then press the Supplemental Circuit Protection button.
Ground Fault	When a fault condition is detected, the Reset button on the GFCI outlet trips and power to the appliance is interrupted.	<p>Reset: To resume normal operation, determine and correct the ground fault, then press the Reset button.</p> <p>Test: Press the Test button on the GFCI outlet with either shore power and/or the RS400 turned to On (⏻). The Reset button should trip. Press the Reset button to reset the GFCI and to continue with normal operation. This test should be performed on a monthly basis.</p> <p>If the Reset button does not trip, the GFCI may have failed. Contact your dealer to have a qualified service person examine the RS400.</p>
Overload	The RS400 is designed to provide 400 watts continuously and 800 watts surge capability for five seconds. If the connected appliances draw more than the rated power, the RS400 will shut down and the red Fault light illuminates.	Disconnect the appliances connected to the inverter and then turn the On/Standby switch on either the inverter’s front panel or the S400 Remote Switch to Standby (⏻) and then to On (⏻). See also “Recharging Your Batteries When Low Battery Light Illuminates” on page 2–5.

3

Troubleshooting

The RS400 is designed for high reliability and has a number of protection features for trouble-free operation. If, however, you have any problems operating your inverter, refer to the “Troubleshooting Reference” on page 3–2.

Read this chapter before calling your dealer or Xantrex Customer Service. See page ii for contact information.

If you cannot resolve the problem, record the information asked for on the form, “Information About Your System” on page WA–4. Providing this information to our Customer Service Representatives will help them to assist you better.

Troubleshooting Reference



WARNING: Electrical shock and fire hazard

Do not disassemble the RS400. It does not contain any user-serviceable parts. Attempting to service the unit yourself could result in electrical shock or fire.

This section provides you with troubleshooting tips to identify and solve most problems that can occur with the RS400.

Before contacting your dealer or customer service, please refer to the “Troubleshooting Reference” table.

If the “Troubleshooting Reference” table does not help you resolve the problem, contact your dealer or Xantrex customer service.

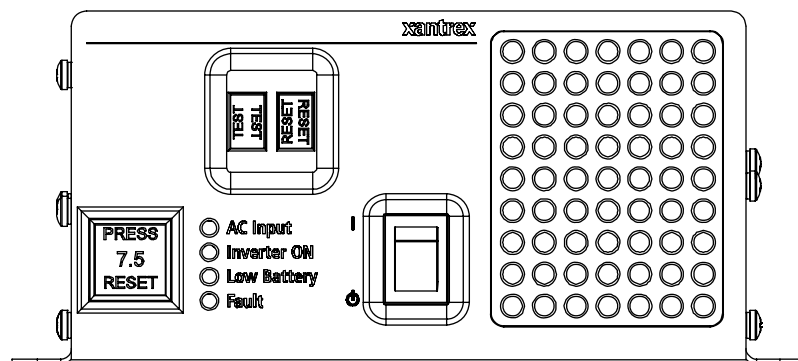

Figure 3-1 Front Panel

For a detailed description of the different features, see “RS400 Features” on page 1-4.

Table 3-1 Troubleshooting Reference

Problem	Possible Cause	Solution
No output voltage. No indicator lights are illuminated.	The switch is in Standby (⏻) mode.	Turn the On/Standby switch to On (⏻).
	No input power to the inverter.	Check the DC wiring to the inverter for loose connections, frayed wiring or an open DC Disconnect.
	DC fuse open (external)	Have a qualified service technician check and replace the fuse.
No output voltage. Inverter ON light is illuminated.	Supplemental Circuit Protection button has tripped.	Disconnect all appliances to reduce the overload. Check the AC wiring, and reset the Supplemental Circuit Protection button.
	GFCI has tripped.	Clear the ground fault, and reset the GFCI by pressing the Reset button on the GFCI.
No output voltage. Fault light is illuminated.	Inverter may be overloaded.	Disconnect all appliances connected to the inverter, and reset the inverter by turning the On/Standby switch to Standby (⏻) and then to On (⏻).
	Battery voltage may be too high.	The inverter will restart if the battery voltage drops below 14.5 volts DC.
	Over temperature.	Allow the inverter to cool down. The inverter will restart automatically.
No output voltage. Low Battery light is illuminated.	Battery voltage is too low.	Recharge the battery to more than 12.6 volts DC. The inverter will restart automatically.
	Poor DC wiring.	Turn the inverter to Standby (⏻). Disconnect the DC wiring. Use proper wiring and ensure all connections are tight.
Output voltage is present. Inverter ON light and Low Battery light are illuminated.	Battery voltage is low.	Disconnect all appliances. Charge the batteries.

Table 3-1 Troubleshooting Reference (Continued)

Problem	Possible Cause	Solution
AC input cord is connected to shore power, but the appliance is not powered from shore power. AC Input light is off.	The shore power voltage is out of range (less than 85 volts AC or greater than 140 volts AC).	Turn the On/Standby switch to On (I), and the appliance will be powered from the inverter.
	External breaker has tripped.	Reset the external breaker.
AC input cord is connected to shore power, but the appliance is not powered from shore power. AC Input light is illuminated.	Supplemental circuit breaker has tripped.	Disconnect all appliances. Check the AC wiring and press the Supplemental Circuit Protection button to reset it.
	GFCI has tripped.	Correct the ground fault and reset the GFCI.
AC input cord is connected to shore power. AC Input light illuminates intermittently.	The shore power voltage is close to being out of range (less than 85 volts AC or greater than 140 volts AC).	Turn On/Standby switch to On (I), and the appliance will be powered from the inverter or shore power.
Fan does not turn on.	The internal components of the inverter are not warm.	No action. The fan will run automatically when necessary to cool the internal components of the inverter.
Fan runs all the time.	The amount of power being consumed by the appliances is high.	No action. The fan will run at lower speeds and stop automatically when the internal temperature of the inverter falls.
	The ambient temperature is high.	No action. The fan will run at lower speeds and stop automatically when the ambient temperature falls. For more information on the “Fan Cooling System”, refer to page A-3

A

Specifications

Appendix A, “Specifications”, contains the electrical and physical specifications for the RS400.

All specifications are subject to change without notice.

Electrical Specifications

Output power at 12 VDC input	
• Continuous	400 VA ¹ , 32 °F to 104 °F (0 °C to 40 °C), derated linearly to 300 VA at 122 °F (50 °C)
• Surge capacity for 5 seconds	800 VA
Input voltage	12 VDC nominal 10.3 to 15.3 VDC
Output voltage	120 VAC RMS ± 3 VAC
Output frequency	60 Hz ± 0.05 Hz
Output wave form	Sine wave
Total harmonic distortion of output waveform	<3%
High battery shutdown	15.3 ± 0.3 VDC
Low battery indication	10.7 ± 0.3 VDC
Low battery shutdown	10.3 ± 0.3 VDC
Maximum efficiency	88%
No load current draw with switch On (I)	1.25 ADC Maximum
No load current draw with switch set to Standby (ϕ)	0 ADC
Circuit breaker	7.5 AAC

¹ The term “watts” has been used throughout the guide to refer to output power. More correctly, the actual unit of power used is “VA”.

Physical Specifications with Projections

Length	13.5 inches (343 mm)
Width	7.36 inches (187 mm)
Height	3.27 inches (83 mm)
Weight	10 lb (4.54 kg)

Regulatory Approvals

CSA/NRTL approved to CSA C22.2 No. 107.1 and UL 458
FCC Class B

Fan Cooling System

A fan cools the internal heat generating components of the inverter. The fan begins to operate when the internal temperature is too high. The speed of the fan increases as the internal temperature rises.

The fan turns off if the internal temperature of the inverter drops.

Transfer Circuit

Transfer circuit	6 Amps, 85 to 140 VAC
------------------	-----------------------

Warranty and Product Information

Warranty

What does this warranty cover? This Limited Warranty is provided by Xantrex Technology, Inc. ("Xantrex") and covers defects in workmanship and materials in your RS400 Sine Wave Inverter. This warranty lasts for a Warranty Period of 12 months from the date of purchase at point of sale to you, the original end user customer.

What will Xantrex do? Xantrex will, at its option, repair or replace the defective product free of charge, provided that you notify Xantrex of the product defect within the Warranty Period, and provided that Xantrex through inspection establishes the existence of such a defect and that it is covered by this Limited Warranty. Xantrex will, at its option, use new and/or reconditioned parts in performing warranty repair and building replacement products. Xantrex reserves the right to use parts or products of original or improved design in the repair or replacement. If Xantrex repairs or replaces a product, its warranty continues for the remaining portion of the original Warranty Period or 90 days from the date of the return shipment to the customer, whichever is greater. All replaced products and all parts removed from repaired products become the property of Xantrex.

Xantrex covers both parts and labor necessary to repair the product, and return shipment to the customer via a Xantrex-selected non-expedited surface freight within the contiguous United States and Canada. Alaska and Hawaii are excluded. Contact Xantrex Customer Service for details on freight policy for return shipments outside of the contiguous United States and Canada.

How do you get service? If your product requires troubleshooting or warranty service, contact your merchant. If you are unable to contact your merchant, or the merchant is unable to provide service, contact Xantrex directly at:

Phone: 1-800-670-0707 (toll free)

1-604-422-2777 (direct)

Fax: 1-604-420-2145

Email: CustomerService@xantrex.com

Direct returns may be performed according to the Xantrex Return Material Authorization Policy described in your product manual. For some products, Xantrex maintains a network of regional Authorized Service Centers. Call Xantrex or check our website to see if your product can be repaired at one of these facilities.

In any warranty claim, dated proof of purchase must accompany the product and the product must not have been disassembled or modified without prior written authorization by Xantrex.

Proof of purchase may be in any one of the following forms:

- The dated purchase receipt from the original purchase of the product at point of sale to the end user, or
- The dated dealer invoice or purchase receipt showing original equipment manufacturer (OEM) status, or
- The dated invoice or purchase receipt showing the product exchanged under warranty

What does this warranty not cover? This Limited Warranty does not cover normal wear and tear of the product or costs related to the removal, installation, or troubleshooting of the customer's electrical systems. This warranty does not apply to and Xantrex will not be responsible for any defect in or damage to:

- a) the product if it has been misused, neglected, improperly installed, physically damaged or altered, either internally or externally, or damaged from improper use or use in an unsuitable environment;
- b) the product if it has been subjected to fire, water, generalized corrosion, biological infestations, or input voltage that creates operating conditions beyond the maximum or minimum limits listed in the Xantrex product specifications including high input voltage from generators and lightning strikes;
- c) the product if repairs have been done to it other than by Xantrex or its authorized service centers (hereafter "ASCs");
- d) the product if it is used as a component part of a product expressly warranted by another manufacturer;
- e) the product if its original identification (trade-mark, serial number) markings have been defaced, altered, or removed.

Disclaimer

Product

THIS LIMITED WARRANTY IS THE SOLE AND EXCLUSIVE WARRANTY PROVIDED BY XANTREX IN CONNECTION WITH YOUR XANTREX PRODUCT AND IS, WHERE PERMITTED BY LAW, IN LIEU OF ALL OTHER WARRANTIES, CONDITIONS, GUARANTEES, REPRESENTATIONS, OBLIGATIONS AND LIABILITIES, EXPRESS OR IMPLIED, STATUTORY OR OTHERWISE IN CONNECTION WITH THE PRODUCT, HOWEVER ARISING (WHETHER BY CONTRACT, TORT, NEGLIGENCE, PRINCIPLES OF MANUFACTURER'S LIABILITY, OPERATION OF LAW, CONDUCT, STATEMENT OR OTHERWISE), INCLUDING WITHOUT RESTRICTION ANY IMPLIED WARRANTY OR CONDITION OF QUALITY, MERCHANTABILITY OR FITNESS FOR A PARTICULAR PURPOSE. ANY IMPLIED WARRANTY OF MERCHANTABILITY OR FITNESS FOR A PARTICULAR PURPOSE TO THE EXTENT REQUIRED UNDER APPLICABLE LAW TO APPLY TO THE PRODUCT SHALL BE LIMITED IN DURATION TO THE PERIOD STIPULATED UNDER THIS LIMITED WARRANTY.

IN NO EVENT WILL XANTREX BE LIABLE FOR ANY SPECIAL, DIRECT, INDIRECT, INCIDENTAL OR CONSEQUENTIAL DAMAGES, LOSSES, COSTS OR EXPENSES HOWEVER ARISING WHETHER IN CONTRACT OR TORT INCLUDING WITHOUT RESTRICTION ANY ECONOMIC LOSSES OF ANY KIND, ANY LOSS OR DAMAGE TO PROPERTY, ANY PERSONAL INJURY, ANY DAMAGE OR INJURY ARISING FROM OR AS A RESULT OF MISUSE OR ABUSE, OR THE INCORRECT INSTALLATION, INTEGRATION OR OPERATION OF THE PRODUCT.

Exclusions

If this product is a consumer product, federal law does not allow an exclusion of implied warranties. To the extent you are entitled to implied warranties under federal law, to the extent permitted by applicable law they are limited to the duration of this Limited Warranty. Some states and provinces do not allow limitations or exclusions on implied warranties or on the duration of an implied warranty or on the limitation or exclusion of incidental or consequential damages, so the above limitation(s) or exclusion(s) may not apply to you. This Limited Warranty gives you specific legal rights. You may have other rights which may vary from state to state or province to province.

Warning: Limitations On Use

Please refer to your product manual for limitations on uses of the product.

SPECIFICALLY, PLEASE NOTE THAT THE RS400 Sine Wave Inverter SHOULD NOT BE USED IN CONNECTION WITH LIFE SUPPORT SYSTEMS OR OTHER MEDICAL EQUIPMENT OR DEVICES. WITHOUT LIMITING THE GENERALITY OF THE FOREGOING, XANTREX MAKES NO REPRESENTATIONS OR WARRANTIES REGARDING THE USE OF THE RS400 Sine Wave Inverter IN CONNECTION WITH LIFE SUPPORT SYSTEMS OR OTHER MEDICAL EQUIPMENT OR DEVICES.

Please note that the RS400 Sine Wave Inverter is not intended for use as an uninterruptible power supply and Xantrex makes no warranty or representation in connection with any use of the product for such purposes.

Return Material Authorization Policy

Before returning a product directly to Xantrex you must obtain a Return Material Authorization (RMA) number and the correct factory "Ship To" address. Products must also be shipped prepaid. Product shipments will be refused and returned at your expense if they are unauthorized, returned without an RMA number clearly marked on the outside of the shipping box, if they are shipped collect, or if they are shipped to the wrong location.

When you contact Xantrex to obtain service, please have your instruction manual ready for reference and be prepared to supply:

- The serial number of your product
- Information about the installation and use of the unit
- Information about the failure and/or reason for the return
- A copy of your dated proof of purchase

Record these details in on page WA-4.

Return Procedure

1. Package the unit safely, preferably using the original box and packing materials. Please ensure that your product is shipped fully insured in the original packaging or equivalent. This warranty will not apply where the product is damaged due to improper packaging.
2. Include the following:
 - The RMA number supplied by Xantrex Technology, Inc. clearly marked on the outside of the box.
 - A return address where the unit can be shipped. Post office boxes are not acceptable.
 - A contact telephone number where you can be reached during work hours.
 - A brief description of the problem.
3. Ship the unit prepaid to the address provided by your Xantrex customer service representative.

If you are returning a product from outside of the USA or Canada In addition to the above, you MUST include return freight funds and are fully responsible for all documents, duties, tariffs, and deposits.

If you are returning a product to a Xantrex Authorized Service Center (ASC) A Xantrex return material authorization (RMA) number is not required. However, you must contact the ASC prior to returning the product or presenting the unit to verify any return procedures that may apply to that particular facility.

Out of Warranty Service

If the warranty period for your RS400 Sine Wave Inverter has expired, if the unit was damaged by misuse or incorrect installation, if other conditions of the warranty have not been met, or if no dated proof of purchase is available, your inverter may be serviced or replaced for a flat fee.

To return your RS400 Sine Wave Inverter for out of warranty service, contact Xantrex Customer Service for a Return Material Authorization (RMA) number and follow the other steps outlined in "Return Procedure" on page WA-3.

Payment options such as credit card or money order will be explained by the Customer Service Representative. In cases where the minimum flat fee does not apply, as with incomplete units or units with excessive damage, an additional fee will be charged. If applicable, you will be contacted by Customer Service once your unit has been received.

Information About Your System

As soon as you open your RS400 Sine Wave Inverter package, record the following information and be sure to keep your proof of purchase.

- Serial Number (on DC end) _____
- Purchased From _____
- Purchase Date _____

If you need to contact Customer Service, please record the following details before calling. This information will help our representatives give you better service.

- Type of installation (e.g. RV, truck) _____
- Length of time inverter has been installed _____
- Battery/battery bank size _____
- Battery type (e.g. flooded, sealed gel cell, AGM) _____
- DC wiring size and length _____
- Alarm sounding? _____
- Description of indicators on front panel _____
- Appliances operating when problem occurred _____
- Description of problem _____

Index

A

AC Input light
described 1-4
illustrated 1-4, 2-2

B

back panel features
described and illustrated 1-5
batteries
explosive gases vi
recharging 2-5
battery chargers 2-5
battery monitors 2-5

C

Customer Service
email WA-1
fax number WA-1
phone number WA-1
preparing to call WA-4

E

email, contacting Customer Service by WA-1
entertainment system 1-2
explosive gases vi

F

fan cooling system A-3
Fault light
described 1-4
illustrated 1-4, 2-2
fax number for Customer Service WA-1
front panel features
described and illustrated 1-4, 2-2

G

gases, explosive vi
GFCI
described 1-4
illustrated 1-4, 2-2
protection 1-3

resetting 2-9

H

high voltage shutdown 1-3

I

indication, low voltage 1-3
indicator lights status 2-8
Information about Your System form WA-4
inverter
purchase date WA-4
serial number WA-4
inverter mode
definition 2-3, 2-5
operating in 2-5
Inverter ON light
described 1-4
illustrated 1-4, 2-2

L

Low Battery light
described 1-4
illustrated 1-4, 2-2
low battery voltage
shutdown 2-6
low voltage indication and shutdown 1-3

O

On/Standby Switch
described 1-4
illustrated 1-4, 2-2
optional remote switch 1-6
turning to standby 2-3
overload protection 1-3
overload, resetting after 2-9
over-temperature shutdown 1-3

P

power output 1-2
proof of purchase WA-4
protection features 1-3

Index

purchase date WA-4

R

regulatory approvals A-3
remote switch option 1-6

S

S400 Remote Switch
 resetting 2-9
safety information v
serial number WA-4
servicing, no user-serviceable parts v
shore power
 definition iv
 out of range 3-4
 range of 2-7
shore power mode
 definition 2-3, 2-7
 operating in 2-7
short circuit protection 1-3
shutdown
 high voltage 1-3
 low voltage 1-3
 over-temperature 1-3
sine wave, effect on entertainment system 1-2
specifications
 electrical A-2
 physical A-2
standby
 RS400 not in use 2-3
Supplemental Circuit Protection button
 described 1-3
 illustrated 1-4, 2-2
 resetting 2-9

T

telephone number for Customer Service WA-1
transfer switch 1-2
troubleshooting 3-3
turning the RS400 to On or standby 2-3

V

ventilation openings
 described 1-4
 illustrated 1-4, 2-2

precautions vi

W

warranty
 out of warranty service WA-3
 terms and conditions WA-1

X

Xantrex
 website iv

Xantrex Technology Inc.

604 422 2777 Tel

604 420 2145 Fax

800 670 0707 Toll Free North America

customerservice@xantrex.com

www.xantrex.com