

LK-LVTB
May 2008

Replaces LW-03, February 2003

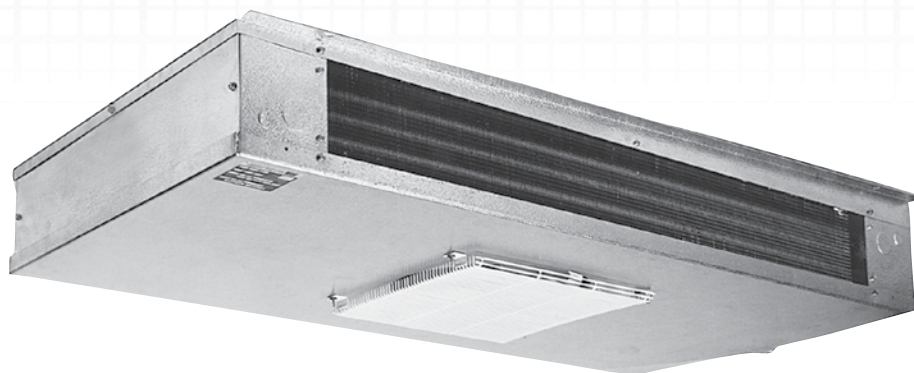
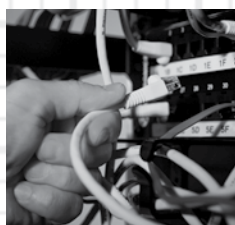

Low Velocity Center Mount Unit Cooler

Technical Guide

Models LWA - Air Defrost

LWE - Electric Defrost

LWG - Hot Gas Defrost

www.larkinproducts.com



Table of Contents

Nomenclature.....	2
Features & Benefits	3
Performance Data & Specifications	
Air Defrost.....	4-5
Electric Defrost.....	6-7
Hot Gas Defrost.....	8-9
Dimensional Data.....	10
Replacement Parts by InterLink™	10
Physical Data.....	11
Standard Nozzle Selection.....	11



We have made a commitment to customer needs, innovation and environmental stewardship and have dedicated ourselves to delivering energy-efficient choices. PSC and EC motors will reduce costs, improve the bottom line and enhance equipment performance and service life.

Choose the most energy-efficient motor available for evaporators.



The EC motor is an Energy Solutions® option on new Larkin Low Velocity Center Mount evaporators. Available on all new equipment or as an easy-to-install, drop-in replacement aftermarket part from InterLink™ Commercial Refrigeration Parts. Because they're a drop-in replacement for existing shaded pole and PSC motors, installation is quick and easy. It's a **high impact, quick payback solution** for reducing costs and achieving green initiatives **without replacing the entire system.**

EC motors by InterLink are **up to 75% efficient** - that's a **51-59% increase over shaded pole motors** and a **30-35% increase over permanent-split capacitor (PSC) motors.** With all of this added efficiency, you can count on more **energy savings and lower operational costs** while taking a step in the right direction toward conserving our planet's resources.

To learn more about EC motors, visit www.interlinkparts.com/ec.

Nomenclature

LW	A	100	A	C
Model Series	Model Type	Capacity	Electrical Code	Design Revision
LW = Larkin Low Velocity Center Mount	A = Air Defrost E = Electric Defrost G = Hot Gas Defrost	# x 100 = BTUH	A = 115/1/60 B = 208-230/1/60 AH = 115/1/60 (PSC) BH = 208-230/1/60 (PSC) AE = 115/1/60 (EC) BE = 208-230/1/60 (EC)	

Features & Benefits

Cabinet

- Low height makes it ideal for low ceiling coolers - larger models are only 15 inches tall, allowing for maximum headroom and more product storage
- Unit designed to be mounted flush against the ceiling or suspended on rods
- Heavy gauge grained aluminum cabinet cleans easily and looks attractive
- Stainless steel screws prevent rust streaks
- Liquid line solenoid wire harness is factory-installed for quick installation
- Wire fan guards with PVC coating for durability
- All electrical components factory wired to terminal board and identified, making it easy to field wire the unit
- Cabinet design features access panels on each end for easy access to electrical and refrigeration components
- Fan panel is lightweight and can easily be lowered for easy servicing and installation
- Expansion valve mounts inside the cabinet

Coils

- Sweat connections to reduce potential for leaks
- Coils are dehydrated and sealed at the factory
- Internally enhanced tubing and fin design for higher efficiency
- Electric defrost models incorporate high quality tubular heaters and a standard fixed defrost termination thermostat
- Hot gas defrost models come with a shipped-loose adjustable fan delay and defrost termination thermostat

Drain Pan

- Double drain pan eliminates drain pan sweating

Motors

- Motor rail is designed for maximum strength and durability
- Motors are life lubricated and thermal overload protected
- EC Motors (optional) available factory-installed or as a drop-in replacement through InterLink™ Commercial Refrigeration Parts in 115/1/60 and 208-230/1/60 voltages
- PSC are optional for 115/1/60 and 208-230/1/60 voltages
- PSC are required for 50 Hz operation

Options

- Unit Configurations: mounted components, pre-assembled, pre-charged and Beacon II™
 - Units available with mounted TXV and mounted TXV / solenoid valve
 - Pre-assembled units come with mounted TXV, liquid line solenoid valve and room thermostat
 - Pre-charged units come with mounted TXV, liquid line solenoid valve, room thermostat and quick connect fittings (limited availability)
 - Mounted room thermostat option
 - Beacon II units come with electronic expansion valves, pressure transducer, temperature sensors and Beacon control board
- Most models available with glycol circuiting (see glycol product brochure)
- Units available with stainless steel housing and drain pan
- Units available with copper fins. Air defrost units also available with polyester coated fins or various coil coatings options

All LW Series units are UL-listed for US and Canada and meet NSF standards

Performance Data

Model LWA Air Defrost | 60 Hz

Model	Capacity								Fan Data		
	10°F TD 25°F SST	6°C TD -4°C SST	15°F TD 25°F SST	8°C TD -4°C SST	50-55°F DB 55% RH 20°F TD				No.	CFM	m³h
	BTUH	Watts	BTUH	Watts	Total		Sensible				
					BTUH	Watts	BTUH	Watts			
LWA050	5,000	1,460	7,500	2,200	10,000	2,930	8,500	2,490	1	725	1,233
LWA075	7,500	2,200	11,250	3,300	15,000	4,390	12,750	3,730	1	730	1,241
LWA100	10,000	2,930	15,000	4,390	20,000	5,860	17,000	4,980	2	1,450	2,465
LWA130	13,000	3,810	19,500	5,710	26,000	7,620	22,100	6,470	2	1,470	2,499
LWA155	15,500	4,540	23,250	6,810	31,000	9,080	26,350	7,720	2	1,460	2,482
LWA180	18,000	5,270	27,000	7,910	36,000	10,540	30,600	8,960	3	2,130	3,621
LWA210	21,000	6,150	31,500	9,230	42,000	12,300	35,700	10,460	4	2,840	4,828
LWA270	27,000	7,910	40,500	11,860	54,000	15,820	45,900	13,440	4	2,800	4,760
LWA340	34,000	9,960	51,000	14,940	68,000	19,920	57,800	16,930	5	3,500	5,950

Model LWA Air Defrost | 50 Hz †

Model	Capacity								Fan Data		
	10°F TD 25°F SST	6°C TD -4°C SST	15°F TD 25°F SST	8°C TD -4°C SST	50-55°F DB 55% RH 20°F TD				No.	CFM	m³h
	BTUH	Watts	BTUH	Watts	Total		Sensible				
					BTUH	Watts	BTUH	Watts			
LWA050	4,800	1,410	7,100	2,080	9,500	2,780	8,100	2,370	1	660	1,122
LWA075	7,100	2,080	10,700	3,130	14,300	4,190	12,100	3,540	1	660	1,122
LWA100	9,500	2,780	14,300	4,190	19,000	5,570	16,200	4,740	2	1,310	2,227
LWA130	12,400	3,630	18,500	5,420	24,700	7,230	21,000	6,150	2	1,330	2,261
LWA155	14,700	4,310	22,100	6,470	29,500	8,640	25,000	7,320	2	1,320	2,244
LWA180	17,100	5,010	25,700	7,530	34,200	10,020	29,100	8,520	3	1,920	3,264
LWA210	20,000	5,860	29,900	8,760	39,900	11,690	33,900	9,930	4	2,560	4,352
LWA270	25,700	7,530	38,500	11,280	51,300	15,030	43,600	12,770	4	2,530	4,301
LWA340	32,300	9,460	48,500	14,210	64,600	18,920	54,900	16,080	5	3,160	5,372

† For EC motors, use 60 Hz capacity and airflow values (Units with EC motors operating at 50 Hz will not see a reduction in performance due to the electronic control of the motor)

Specifications

Model LWA Air Defrost | 60 Hz

Model	Shaded Pole Motor				PSC Motor				EC Motor			
	115/1/60		230/1/60		115/1/60		230/1/60		115/1/60		230/1/60	
	Amps	Watts	Amps	Watts	Amps	Watts	Amps	Watts	Amps	Watts	Amps	Watts
LWA050	2.1	135	1.1	135	0.9	90	0.5	90	0.9	55	0.5	55
LWA075	2.1	135	1.1	135	0.9	90	0.5	90	0.9	55	0.5	55
LWA100	4.2	270	2.2	270	1.8	180	1.0	180	1.8	110	1.0	110
LWA130	4.2	270	2.2	270	1.8	180	1.0	180	1.8	110	1.0	110
LWA155	4.2	270	2.2	270	1.8	180	1.0	180	1.8	110	1.0	110
LWA180	6.3	405	3.3	405	2.7	270	1.5	270	2.7	165	1.5	165
LWA210	8.4	540	4.4	540	3.6	360	2.0	360	3.6	220	2.0	220
LWA270	8.4	540	4.4	540	3.6	360	2.0	360	3.6	220	2.0	220
LWA340	10.5	675	5.5	675	4.5	450	2.5	450	4.5	275	2.5	275

Model LWA Air Defrost | 50 Hz

Model	PSC Motor				EC Motor			
	110/1/50		220/1/50		110/1/50		220/1/50	
	Amps	Watts	Amps	Watts	Amps	Watts	Amps	Watts
LWA050	0.8	80	0.4	80	0.9	55	0.5	55
LWA075	0.8	80	0.4	80	0.9	55	0.5	55
LWA100	1.7	160	0.8	160	1.8	110	1.0	110
LWA130	1.7	160	0.8	160	1.8	110	1.0	110
LWA155	1.7	160	0.8	160	1.8	110	1.0	110
LWA180	2.5	240	1.2	240	2.7	165	1.5	165
LWA210	3.3	320	1.6	320	3.6	220	2.0	220
LWA270	3.3	320	1.6	320	3.6	220	2.0	220
LWA340	4.2	400	2.0	400	4.5	275	2.5	275

Performance Data

Model LWE Electric Defrost | 60 Hz

Model	Capacity				Fan Data		
	10°F TD 25°F SST	6°C TD -4°C SST	15°F TD 25°F SST	8°C TD -4°C SST	No.	CFM	m ³ h
	BTUH	Watts	BTUH	Watts			
LWE050	5,000	1,460	7,500	2,200	1	725	1,233
LWE075	7,500	2,200	11,250	3,300	1	730	1,241
LWE100	10,000	2,930	15,000	4,390	2	1,450	2,465
LWE130	13,000	3,810	19,500	5,710	2	1,470	2,499
LWE155	15,500	4,540	23,250	6,810	2	1,460	2,482
LWE180	18,000	5,270	27,000	7,910	3	2,130	3,621
LWE210	21,000	6,150	31,500	9,230	4	2,840	4,828
LWE270	27,000	7,910	40,500	11,860	4	2,800	4,760
LWE340	34,000	9,960	51,000	14,940	5	3,500	5,950

Model LWE Electric Defrost | 50 Hz †

Model	Capacity				Fan Data		
	10°F TD 25°F SST	6°C TD -4°C SST	15°F TD 25°F SST	8°C TD -4°C SST	No.	CFM	m ³ h
	BTUH	Watts	BTUH	Watts			
LWE050	4,800	1,410	7,100	2,080	1	660	1,122
LWE075	7,100	2,080	10,700	3,130	1	660	1,122
LWE100	9,500	2,780	14,300	4,190	2	1,310	2,227
LWE130	12,400	3,630	18,500	5,420	2	1,330	2,261
LWE155	14,700	4,310	22,100	6,470	2	1,320	2,244
LWE180	17,100	2,010	25,700	7,530	3	1,920	3,264
LWE210	20,000	2,860	29,900	8,760	4	2,560	4,352
LWE270	25,700	7,530	38,500	11,280	4	2,530	4,301
LWE340	32,300	9,460	48,500	14,210	5	3,160	5,372

† For EC motors, use 60 Hz capacity and airflow values (Units with EC motors operating at 50 Hz will not see a reduction in performance due to the electronic control of the motor)

Specifications

Model LWE Electric Defrost | 60 Hz

Model	Shaded Pole Motor		PSC Motor		EC Motor		Defrost Heater	
	230/1/60		230/1/60		230/1/60		Watts	230/1/60
	Amps	Watts	Amps	Watts	Amps	Watts		Total Amps
LWE050	1.1	135	0.5	90	0.5	55	2,000	8.7
LWE075	1.1	135	0.5	90	0.5	55	2,400	10.5
LWE100	2.2	270	1.0	180	1.0	110	2,800	12.2
LWE130	2.2	270	1.0	180	1.0	110	4,000	17.4
LWE155	2.2	270	1.0	180	1.0	110	4,000	17.4
LWE180	3.3	405	1.5	270	1.5	165	4,000	17.4
LWE210	4.4	540	2.0	360	2.0	220	5,200	22.6
LWE270	4.4	540	2.0	360	2.0	220	5,200	22.6
LWE340	5.5	810	2.5	450	2.5	275	7,000	30.4

Model LWE Electric Defrost | 50 Hz

Model	PSC Motor		EC Motor		Defrost Heater	
	220/1/50		220/1/50		Watts	220/1/50
	Amps	Watts	Amps	Watts		Total Amps
LWE050	0.4	80	0.5	55	1,830	8.3
LWE075	0.4	80	0.5	55	2,200	10.0
LWE100	0.8	160	1.0	110	2,560	11.6
LWE130	0.8	160	1.0	110	3,660	16.6
LWE155	0.8	160	1.0	110	3,660	16.6
LWE180	1.2	240	1.5	165	3,660	16.6
LWE210	1.6	320	2.0	220	4,760	21.6
LWE270	1.6	320	2.0	220	4,760	21.6
LWE340	2.0	400	2.5	275	6,400	29.1

Performance Data

Model LWG Hot Gas Defrost | 60 Hz

Model	Capacity				Fan Data		
	10°F TD 25°F SST	6°C TD -4°C SST	15°F TD 25°F SST	8°C TD -4°C SST	No.	CFM	m ³ h
	BTUH	Watts	BTUH	Watts			
LWG100	10,000	2,930	15,000	4,390	2	1,450	2,465
LWG130	13,000	3,810	19,500	5,710	2	1,470	2,499
LWG155	15,500	4,540	23,250	6,810	2	1,460	2,482
LWG180	18,000	5,270	27,000	7,910	3	2,130	3,621
LWG210	21,000	6,150	31,500	9,230	4	2,840	4,828
LWG270	27,000	7,910	40,500	11,860	4	2,800	4,760
LWG340	34,000	9,960	51,000	14,940	5	3,500	5,950

Model LWG Hot Gas Defrost | 50 Hz †

Model	Capacity				Fan Data		
	10°F TD 25°F SST	6°C TD -4°C SST	15°F TD 25°F SST	8°C TD -4°C SST	No.	CFM	m ³ h
	BTUH	Watts	BTUH	Watts			
LWG100	9,500	2,780	14,300	4,190	2	1,310	2,227
LWG130	12,400	3,630	18,500	5,420	2	1,330	2,261
LWG155	14,700	4,310	22,100	6,470	2	1,320	2,244
LWG180	17,100	5,010	25,700	7,530	3	1,920	3,264
LWG210	20,000	5,860	29,900	8,760	4	2,560	4,352
LWG270	25,700	7,530	38,500	11,280	4	2,530	4,301
LWG340	32,300	9,460	48,500	14,210	5	3,160	5,372

† For EC motors, use 60 Hz capacity and airflow values (Units with EC motors operating at 50 Hz will not see a reduction in performance due to the electronic control of the motor)

Optional Liquid Line Bypass Kit For Hot Gas Defrost

The LWG may be field piped for hot gas defrost using the optional bypass kit.

When compressor vapor, in reverse cycle defrosting, is directed back into the evaporator at the suction connection, it condenses into liquid. The field-installed liquid line bypass kit directs the condensed liquid around the thermostatic expansion valve and back into the liquid line.

Bypass kits include bypass piping, check valve and instructions. Adjustable fan control is shipped loose with hot gas units.

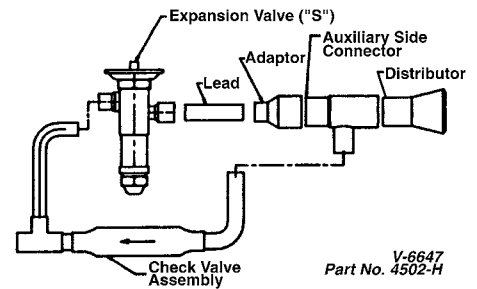

Specifications

Model LWG Hot Gas Defrost | 60 Hz

Model	Shaded Pole Motor				PSC Motor				EC Motor				Drain Pan Heater		
	115/1/60		208-230/1/60		115/1/60		208-230/1/60		115/1/60		208-230/1/60		Watts	115/1/60	230/1/60
	Amps	Watts	Amps	Watts	Amps	Watts	Amps	Watts	Amps	Watts	Amps	Watts		Total Amps	
LWG100	4.2	270	2.2	270	1.8	180	1.0	180	1.8	110	1.0	110	350	3.0	1.5
LWG130	4.2	270	2.2	270	1.8	180	1.0	180	1.8	110	1.0	110	500	4.4	2.2
LWG155	4.2	270	2.2	270	1.8	180	1.0	180	1.8	110	1.0	110	500	4.4	2.2
LWG180	6.3	405	3.3	405	2.7	270	1.5	270	2.7	165	1.5	165	500	4.4	2.2
LWG210	8.4	540	4.4	540	3.6	360	2.0	360	3.6	220	2.0	220	650	5.7	2.8
LWG270	8.4	540	4.4	540	3.6	360	2.0	360	3.6	220	2.0	220	650	5.7	2.8
LWG340	10.5	675	5.5	675	4.5	450	2.5	450	4.5	275	2.5	275	875	7.6	3.8

Model LWG Hot Gas Defrost | 50 Hz

Model	PSC Motor				EC Motor				Drain Pan Heater		
	110/1/50		220/1/50		110/1/50		220/1/50		Watts	110/1/50	220/1/50
	Amps	Watts	Amps	Watts	Amps	Watts	Amps	Watts		Total Amps	
LWG100	1.7	160	0.8	160	1.8	110	1.0	110	320	2.9	1.5
LWG130	1.7	160	0.8	160	1.8	110	1.0	110	460	4.2	2.1
LWG155	1.7	160	0.8	160	1.8	110	1.0	110	460	4.2	2.1
LWG180	2.5	240	1.2	240	2.7	165	1.5	165	460	4.2	2.1
LWG210	3.3	320	1.6	320	3.6	220	2.0	220	595	5.4	2.7
LWG270	3.3	320	1.6	320	3.6	220	2.0	220	595	5.4	2.7
LWG340	4.2	400	2.0	400	4.5	275	2.5	275	800	7.3	3.6

Dimensional Data

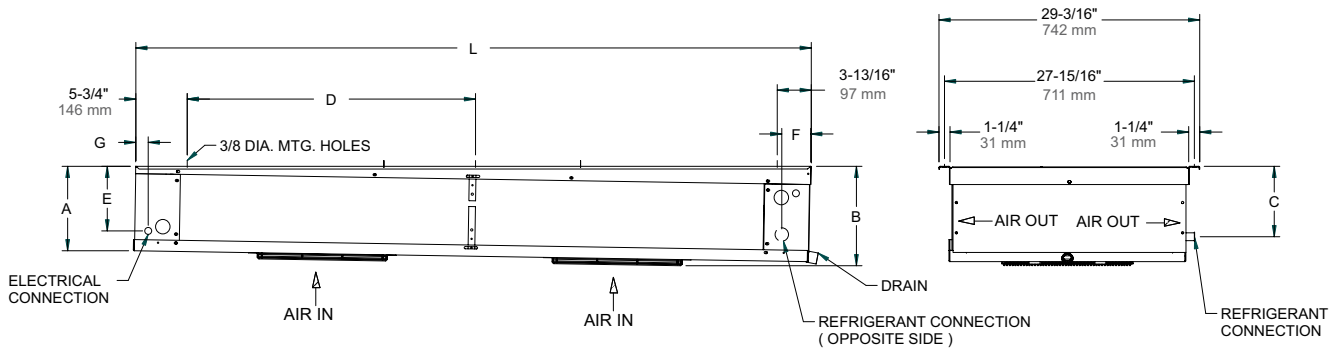

All Models Dimensional Data

Model Numbers by Defrost Types			Dimensions															
			A		B		C		D		E		F		G		L	
Air	Electric	Hot Gas	in.	mm	in.	mm	in.	mm	in.	mm	in.	mm	in.	mm	in.	mm	in.	mm
LWA050	LWE050	-	6-7/8	175	8-7/8	225	6-1/16	154	-	-	4-5/8	118	3-1/4	83	1-5/8	41	53-1/2	1,359
LWA075	LWE075	-	6-7/8	175	8-7/8	225	6-1/16	154	-	-	4-5/8	118	3-1/4	83	1-5/8	41	75-1/2	1,918
LWA100	LWE100	LWG100	9-3/8	238	11-3/8	289	8-9/16	218	-	-	7-1/8	181	3-1/4	83	1-5/8	41	75-1/2	1,918
LWA130	LWE130	LWG130	13-1/8	333	15-1/8	384	12-1/8	308	-	-	8-1/2	216	2-11/16	68	1-1/8	29	75-1/2	1,918
LWA155	LWE155	LWG155	13-1/8	333	15-1/8	384	12-1/8	308	-	-	8-1/2	216	2-11/16	68	1-1/8	29	75-1/2	1,918
LWA180	LWE180	LWG180	13-1/8	333	15-1/8	384	12-1/8	308	-	-	8-1/2	216	2-11/16	68	1-1/8	29	75-1/2	1,918
LWA210	LWE210	LWG210	13-1/8	333	15-1/8	384	12-1/8	308	44	1,118	8-1/2	216	2-11/16	68	1-1/8	29	97-1/2	2,477
LWA270	LWE270	LWG270	13-1/8	333	15-1/8	384	12-1/8	308	44	1,118	8-1/2	216	2-11/16	68	1-1/8	29	97-1/2	2,477
LWA340	LWE340	LWG340	13-1/8	333	15-1/8	384	12-1/8	308	55	1,397	8-1/2	216	2-11/16	68	1-1/8	29	119-1/2	3,035

Replacement Parts



Right source. Right parts. Right now.

InterLink™ is your link to a complete line of dependable and certified commercial refrigeration parts, accessories and innovative electronic controls for all Larkin equipment. At InterLink, we provide our wholesalers with a comprehensive selection of product solutions and innovative technologies for the installed customer base. And every product is built to ensure the same high performance standards with which all Heatcraft Refrigeration Products (HRP) brands are built — backed by a dedicated team to serve every customer need, delivering at the best lead times in the industry.

Dependable. Versatile. Courteous.

Finally, one simple source for all your replacement needs from a name you can trust.

For parts, please contact (800) 686-7278 or visit www.interlinkparts.com.

No. Fans	Air Defrost	Electric Defrost	Hot Gas Defrost
1	050-075	050-075	-
2	100-155	100-155	100-155
3	180	180	180
4	210-270	210-270	210-270
5	340	340	340

Electrical Components/Miscellaneous

Part #	Description	No. Fans
22512601	Terminal Strip	1 - 5
5521R	Defrost Termination	1 - 5
2891040	Room Thermostat	1 - 5
5708L	Heater Safety	1 - 5
4550G	Filters	1 - 5

Motor/Fan Blade/Fan Guards

Part #	Description	No. Fans
5036SS	Motor 115/1/60 Shaded Pole	1 - 5
5036TS	Motor 208-230/1/60 Shaded Pole	1 - 5
5036NS	Motor 115/1/60/50 PSC	1 - 5
5036PS	Motor 208-230/1/60/50 PSC	1 - 5
25305901	Motor 460/1/60/50 PSC	1 - 5
25318001	Motor 115/1/60 EC	1 - 5
25317901	Motor 208-230/1/60 EC	1 - 5
5110E	Fan Blade	1 - 5
5055F	Fan Guard - Wire	1 - 5
40003001	Motor Mount	1 - 5

Cabinet Components

Part #	Description	No. Fans
C26769A2	Drain Pan-Stucco	1
C26771A2	Drain Pan-Stucco	2
C26361A2	Drain Pan-Stucco	3
C26362A2	Drain Pan-Stucco	4
D20817A2	Drain Pan-Stucco	5
C26769A4	Drain Pan-White	1
C26771A4	Drain Pan-White	2
C26361A4	Drain Pan-White	3
C26362A4	Drain Pan-White	4
D20817A4	Drain Pan-White	5

Electric Defrost

Part #	Description	No. Fans
Consult Factory	Coil Heater	1
4544B	Coil Heater	2
4544B	Coil Heater	3
4545B	Coil Heater	4
4546B	Coil Heater	5

Physical Data

LWA Air Defrost

Model	No. of Fans	Connections (in.)		Aprox. Net Wt.	
		Liquid OD	Suction OD	lbs.	kg
LWA050	1	1/2	7/8	70	32
LWA075	1	1/2	7/8	103	47
LWA100	2	1/2	7/8	106	48
LWA130	2	1-1/8	1-1/8	145	66
LWA155	2	1-1/8	1-1/8	149	68
LWA180	3	1-1/8	1-1/8	160	73
LWA210	4	1-1/8	1-1/8	193	88
LWA270	4	1-3/8	1-3/8	200	91
LWA340	5	1-3/8	1-3/8	242	110

LWE Electric Defrost

Model	No. of Fans	Connections (in.)		Aprox. Net Wt.	
		Liquid OD	Suction OD	lbs.	kg
LWE050	1	1/2	7/8	75	34
LWE075	1	1/2	7/8	108	49
LWE100	2	1/2	7/8	111	50
LWE130	2	1-1/8	1-1/8	150	68
LWE155	2	1-1/8	1-1/8	154	70
LWE180	3	1-1/8	1-1/8	157	71
LWE210	4	1-1/8	1-1/8	203	92
LWE270	4	1-3/8	1-3/8	208	94
LWE340	5	1-3/8	1-3/8	250	113

LWG Hot Gas Defrost

Model	No. of Fans	Connections (in.)		Aprox. Net Wt.	
		Liquid OD	Suction OD	lbs.	kg
LWG100	2	1/2	7/8	131	59
LWG130	2	1-1/8	1-1/8	170	77
LWG155	2	1-1/8	1-1/8	174	79
LWG180	3	1-1/8	1-1/8	185	84
LWG210	4	1-1/8	1-1/8	223	101
LWG270	4	1-3/8	1-3/8	228	103
LWG340	5	1-3/8	1-3/8	270	122

NOTE: All units have 1/4" OD external equalizer and 3/4" FPT drain connection

Standard Nozzle Selection

Model LWA Air Defrost

Model	No. of Fans	Distributor Tube (in.)		No. of Circuits	R-404A*	R-22
		OD	Length			
LWA050	1	3/16	18	2	L-1/2	L-1/3
LWA075	1	3/16	18	4	L-3/4	L-1/2
LWA100	2	3/16	18	6	L-1	L-3/4
LWA130	2	3/16	24	12	E-1-1/2	E-1
LWA155	2	3/16	24	10	E-2	E-1
LWA180	3	3/16	24	12	E-2	E-1-1/2
LWA210	4	3/16	24	12	E-2-1/2	E-1-1/2
LWA270	4	3/16	24	20	C-3	C-2
LWA340	5	3/16	24	20	C-4	C-2-1/2

Model LWE Electric Defrost

Model	No. of Fans	Distributor Tube (in.)		No. of Circuits	R-404A*	R-22
		OD	Length			
LWE050	1	3/16	18	2	L-1/2	L-1/3
LWE075	1	3/16	18	4	L-1	L-3/4
LWE100	2	3/16	18	6	L-1-1/2	L-3/4
LWE130	2	3/16	24	12	E-1-1/2	E-1
LWE155	2	3/16	24	10	E-2	E-1-1/2
LWE180	3	3/16	24	12	E-2	E-1-1/2
LWE210	4	3/16	24	12	E-2-1/2	E-2
LWE270	4	3/16	24	20	C-3	C-2
LWE340	5	3/16	24	20	C-4	C-2-1/2

Model LWG Hot Gas Defrost

Model	No. of Fans	Distributor Tube (in.)		No. of Circuits	R-404A*	R-22
		OD	Length			
LWG100	2	3/16	18	6	L-1-1/2	L-3/4
LWG130	2	3/16	24	12	E-1-1/2	E-1
LWG155	2	3/16	24	10	E-2	E-1-1/2
LWG180	3	3/16	24	12	E-2	E-1-1/2
LWG210	4	3/16	24	12	E-2-1/2	E-2
LWG270	4	3/16	24	20	C-3	C-2
LWG340	5	3/16	24	20	C-4	C-2-1/2

*Also suitable for R-507, R-502, R-134A, R-401A, R-402A

NOTE: Nozzles sized for 95°F liquid temp. at expansion valve. Refer to manual H-IM-64 if liquid temp. is not 95°F

Room temperature of 35°F for air defrost models and 28°F for electric/hot gas models

Consult Larkin Application Engineering if evaporator TD is not 10° - 15°F, (room temp. - saturated suction temp.)

Caution: Refrigeration system will not perform properly without correct nozzle!

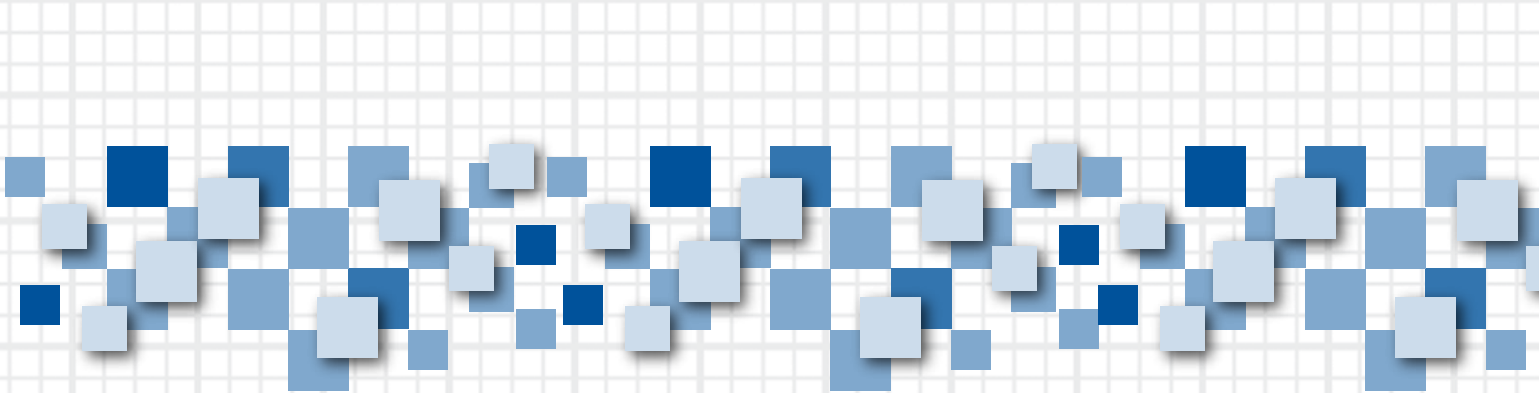

For more information on Larkin refrigeration products, contact your Sales Representative or visit our web site at www.larkinproducts.com.



Mastering the Art of Cold



A Brand of Heatcraft Refrigeration Products LLC
2175 West Park Place Blvd. • Stone Mountain, GA 30087
800.848.9889 • Fax: 770.465.5990
www.larkinproducts.com

Since product improvement is a continuing effort, we reserve the right to make changes in specifications without notice.