

WESLO[®] Sport 100

Class H Fitness Product

Model No. WETL1214.0

Serial No. _____

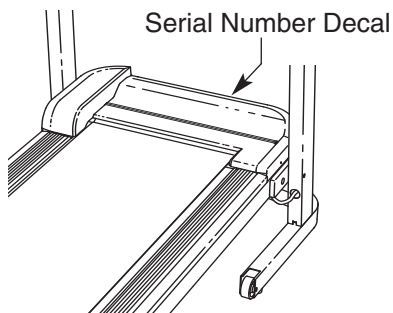

USER'S MANUAL

QUESTIONS?

As a manufacturer, we are committed to providing complete customer satisfaction. If you have questions, or if there are missing or damaged parts, please call:

08457 089 009

Or write:

ICON Health & Fitness, Ltd.
Unit 4
Revie Road Industrial Estate
Revie Road, Beeston
Leeds, LS11 8JG
UK

csuk@iconeurope.com

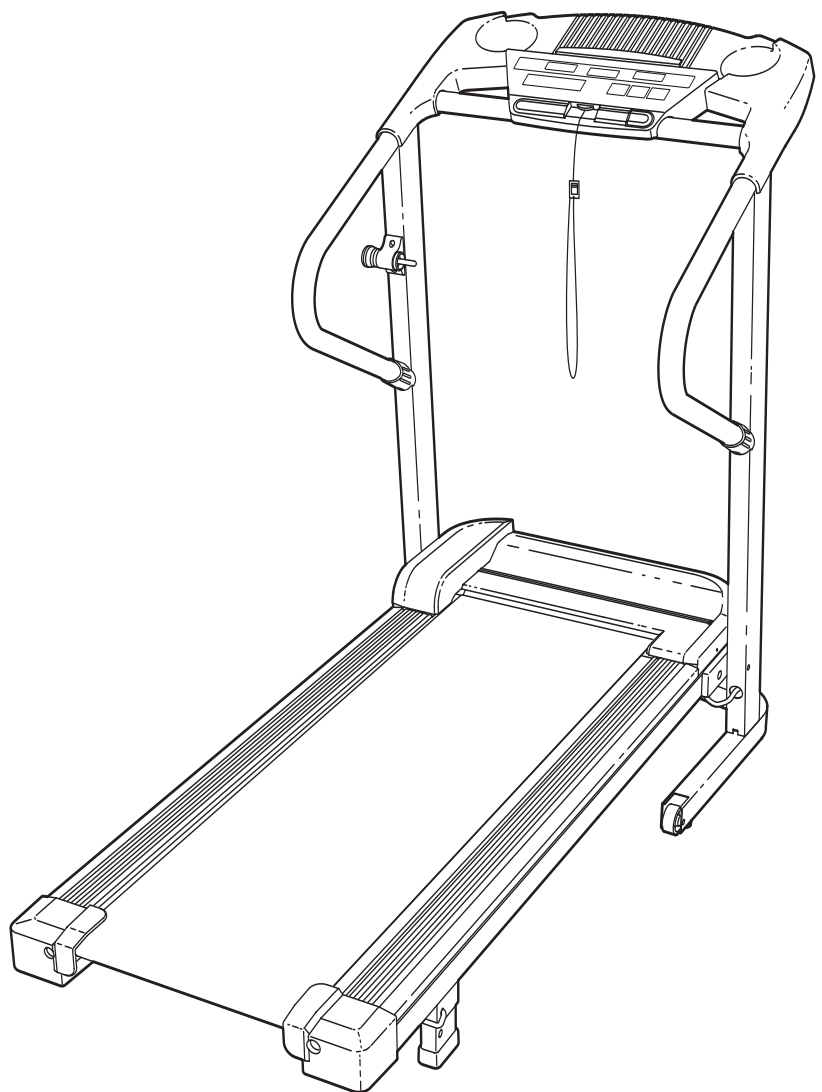

CAUTION

Read all precautions and instructions in this manual before using this equipment. Save this manual for future reference.



Visit our website at

www.iconeurope.com

WESLO[®] Sport 100

TABLE OF CONTENTS

IMPORTANT PRECAUTIONS	3
BEFORE YOU BEGIN	5
ASSEMBLY	6
OPERATION AND ADJUSTMENT	11
HOW TO FOLD AND MOVE THE TREADMILL	14
MAINTENANCE AND TROUBLESHOOTING	16
CONDITIONING GUIDELINES	18
PART LIST	21
EXPLODED DRAWING	22
ORDERING REPLACEMENT PARTSBack Cover

IMPORTANT PRECAUTIONS

⚠ WARNING: To reduce the risk of burns, fire, electric shock, or injury to persons, read the following important precautions and information before operating the treadmill.

1. It is the responsibility of the owner to ensure that all users of this treadmill are adequately informed of all warnings and precautions.
2. Use the treadmill only as described in this manual.
3. Place the treadmill on a level surface, with at least 2.5 m (8 ft.) of clearance behind it and 0.5 m (2 ft.) on each side. Do not place the treadmill on any surface that blocks air openings. To protect the floor or carpet from damage, place a mat under the treadmill.
4. Keep the treadmill indoors, away from moisture and dust. Do not put the treadmill in a garage or covered patio, or near water.
5. Do not operate the treadmill where aerosol products are used or where oxygen is being administered.
6. Keep children under the age of 12 and pets away from the treadmill at all times.
7. The treadmill should not be used by persons weighing more than 115 kg (250 lbs.).
8. Never allow more than one person on the treadmill at a time.
9. Wear appropriate exercise clothes when using the treadmill. Do not wear loose clothes that could become caught in the treadmill. Athletic support clothes are recommended for both men and women. *Always wear athletic shoes. Never use the treadmill with bare feet, wearing only stockings, or in sandals.*
10. When connecting the power cord (see page 11), plug the power cord into an earthed circuit. No other appliance should be on the same circuit. When replacing the fuse, an ASTA approved BS1362 type should be fitted to the fuse carrier. A 13 amp fuse should be used.
11. If an extension cord is needed, use only a 3-conductor, 1mm² (14-gauge) cord that is no longer than 1.5 m (5 ft.).
12. Keep the power cord away from heated surfaces.
13. Never move the walking belt whilst the power is turned off. Do not operate the treadmill if the power cord or plug is damaged, or if the treadmill is not working properly. (See **BEFORE YOU BEGIN** on page 5 if the treadmill is not working properly.)
14. Never start the treadmill whilst you are standing on the walking belt. Always hold the handrails whilst using the treadmill.
15. The treadmill is capable of high speeds. Adjust the speed in small increments to avoid sudden jumps in speed.
16. Never leave the treadmill unattended while it is running. Always remove the key, unplug the power cord, and move the on/off switch to the off position when the treadmill is not in use. (See the drawing on page 5 for the location of the on/off switch.)
17. Do not attempt to raise, lower, or move the treadmill until it is properly assembled. (See **ASSEMBLY** on page 6 and **HOW TO FOLD AND MOVE THE TREADMILL** on page 14.) You must be able to safely lift 20 kg (45 lbs.) to raise, lower, or move the treadmill.
18. When folding or moving the treadmill, make sure that the storage latch is fully closed.
19. Do not change the incline of the treadmill by placing objects under the treadmill.
20. Inspect and properly tighten all parts of the treadmill regularly.
21. Never drop or insert any object into any opening.

22. **DANGER:** Always unplug the power cord immediately after use, before cleaning the treadmill, and before performing the maintenance and adjustment procedures described in this manual. Never remove the motor hood unless instructed to do so by an authorised service representative. Servicing

other than the procedures in this manual should be performed by an authorised service representative only.

23. This treadmill is intended for in-home use only. Do not use this treadmill in any commercial, rental, or institutional setting.

!WARNING: Before beginning this or any exercise program, consult your physician. This is especially important for persons over the age of 35 or persons with pre-existing health problems. Read all instructions before using. ICON assumes no responsibility for personal injury or property damage sustained by or through the use of this product.

SAVE THESE INSTRUCTIONS

The decal shown has been placed on your treadmill. If the decal is missing, or if it is not legible, please call our Customer Service Department and order a free replacement decal (see ORDERING REPLACEMENT PARTS on the back cover of this manual). Apply the replacement decal in the location shown.

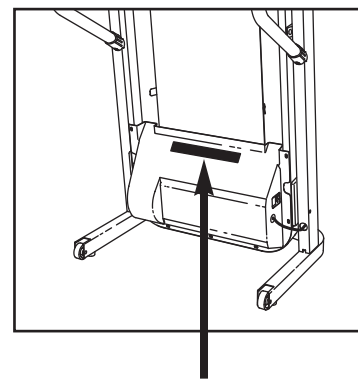

Note: This decal is not shown at actual size.

!WARNING: Protect yourself and others from risk of serious injury. Read the user's manual and:

- Fully engage storage latch before treadmill is moved or stored.
- Reduce incline to lowest level before folding treadmill into storage position.



- Stand only on side rails when starting or stopping treadmill.
- Change speed in small increments.
- Hold handrails to prevent falling, and always wear the safety clip while operating treadmill.
- Stop if you feel faint, dizzy, or short of breath.



- Never allow children on or around treadmill.
- Remove key when not in use.



- Keep clothing, fingers, and hair away from moving belt.
- Never try to adjust or fix the belt while it is moving.
- Always wear athletic shoes while operating treadmill.

BEFORE YOU BEGIN

Thank you for selecting the WESLO® SPORT 100 treadmill. The SPORT 100 treadmill combines advanced technology with innovative design to let you enjoy an excellent form of cardiovascular exercise in the convenience and privacy of your home. And when you're not exercising, the unique SPORT 100 treadmill can be folded up, requiring less than half the floor space of other treadmills.

For your benefit, read this manual carefully before using the treadmill. If you have questions after read-

ing this manual, please call our Customer Service Department at **08457 089 009**. To help us assist you, please note the product model number and serial number before calling. The model number of the treadmill is WETL1214.0. The serial number can be found on a decal attached to the treadmill (see the front cover of this manual for the location of the decal).

Before reading further, please review the drawing below and familiarise yourself with the labelled parts.

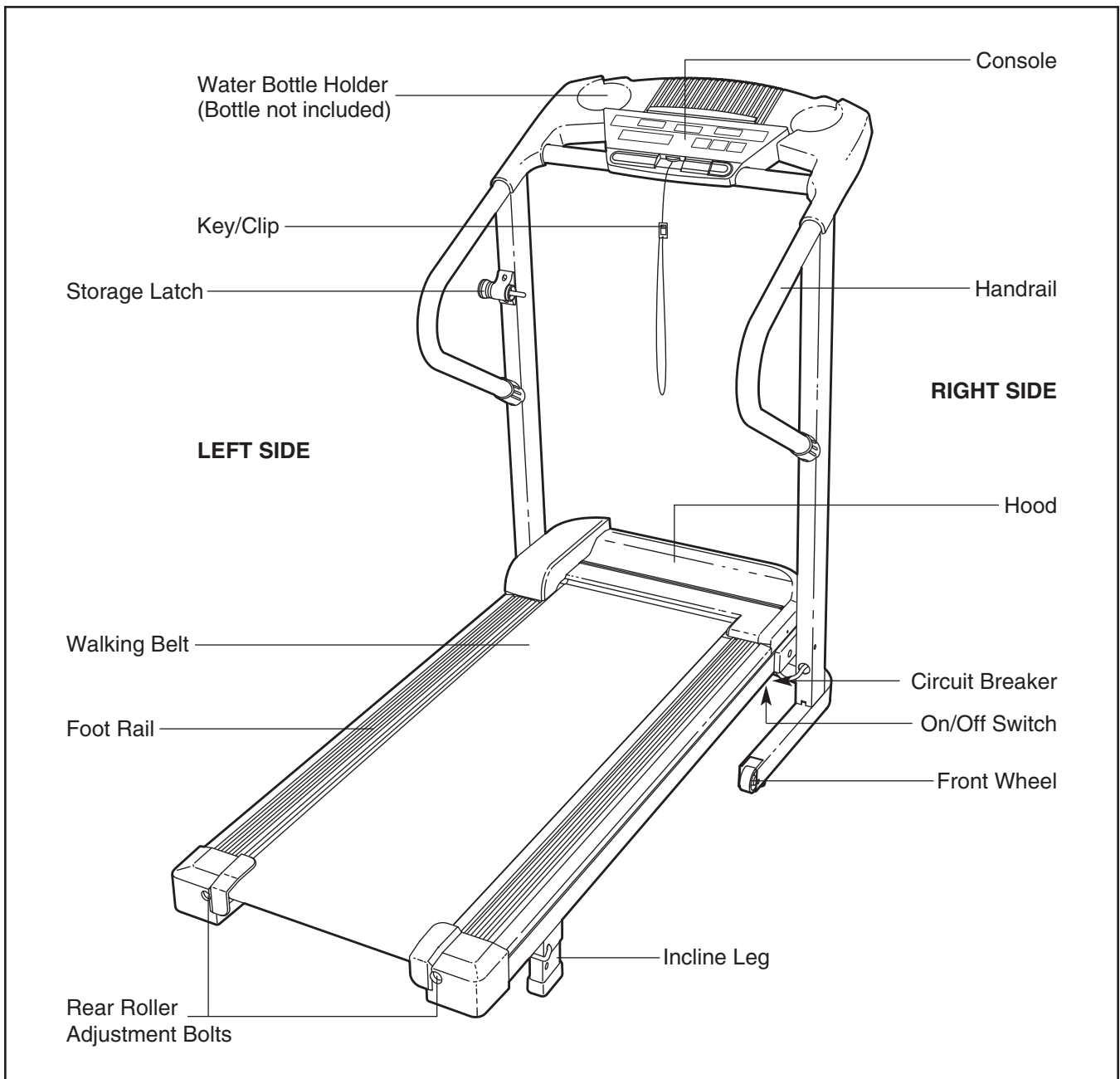

ASSEMBLY

Assembly requires two persons. Place a mat under the treadmill to protect the floor during assembly. Set the treadmill in a cleared area and remove all packing materials. Do not dispose of the packing materials until assembly is completed. Note: The underside of the treadmill walking belt is coated with high-performance lubricant. During shipping, a small amount of lubricant may be transferred to the top of the walking belt or the shipping carton. This is a normal condition and does not affect treadmill performance. If there is lubricant on top of the walking belt, simply wipe off the lubricant with a soft cloth and a mild, non-abrasive cleaner.

Assembly requires the included hex key  and your own phillips screwdriver , adjustable spanner , wire cutters , and needlenose pliers .

For help identifying the assembly hardware, see the part identification chart below.

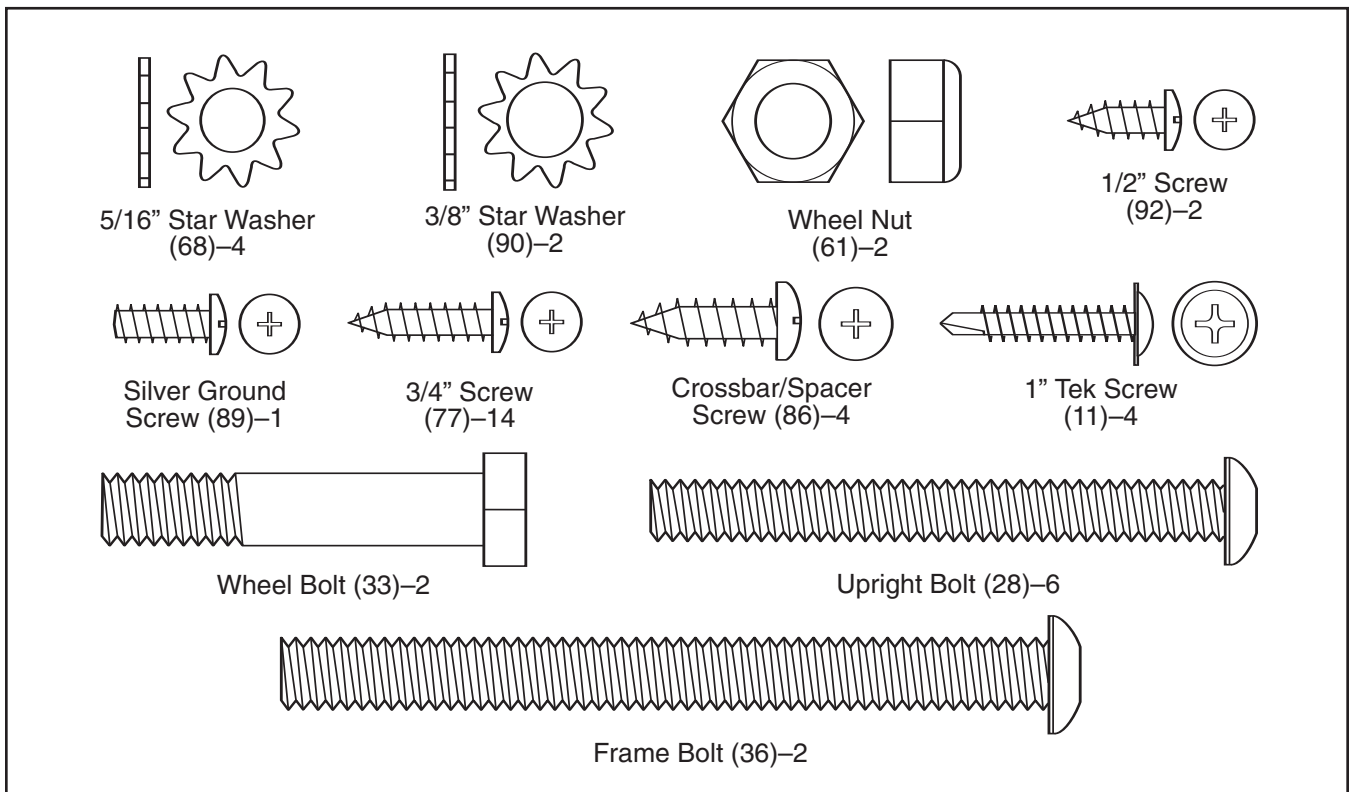

⚠ WARNING: Do not plug in the power cord until the treadmill is completely assembled.

1. Orient the Base (55) so the holes for the four Base Pads (31) are on top. Attach the four Base Pads to the Base with the four 1" Tek Screws (11).

Attach the two Wheels (34) to the Base (55) with two Wheel Bolts (33) and two Wheel Nuts (61) as shown. **Do not overtighten the Bolts. The Wheels must be able to turn freely.**

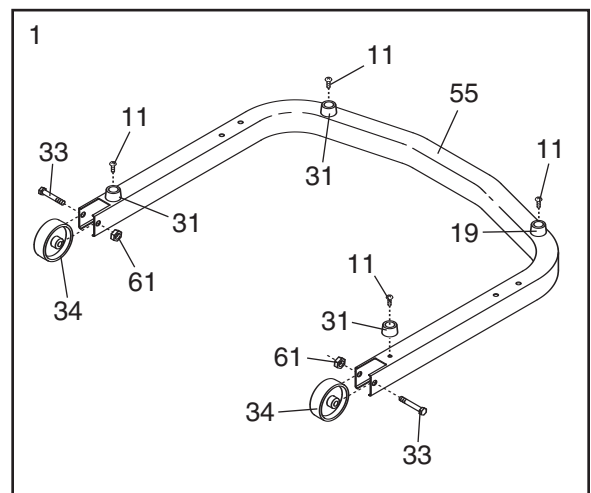

- Identify the Left Upright (32) and the Right Upright (37), which has a large round hole near the lower end.

See drawing 2a. Make sure that there are two U-nuts (93) in the lower end of each Upright (32, 37).

See drawing 2b. Have a second person hold the Base (55) so it is resting on the Wheels (34) as shown. **Make sure that the Base is oriented so that the Base Pads (31) are in the location shown.** Attach the Right and Left Uprights (32, 37) to the Base with four Upright Bolts (28) and four 5/16" Star Washers (68). **Do not tighten the Bolts yet. Make sure that the large hole in the Right Upright is on the side shown, and that the two small holes in the Left Upright are on the side shown.**

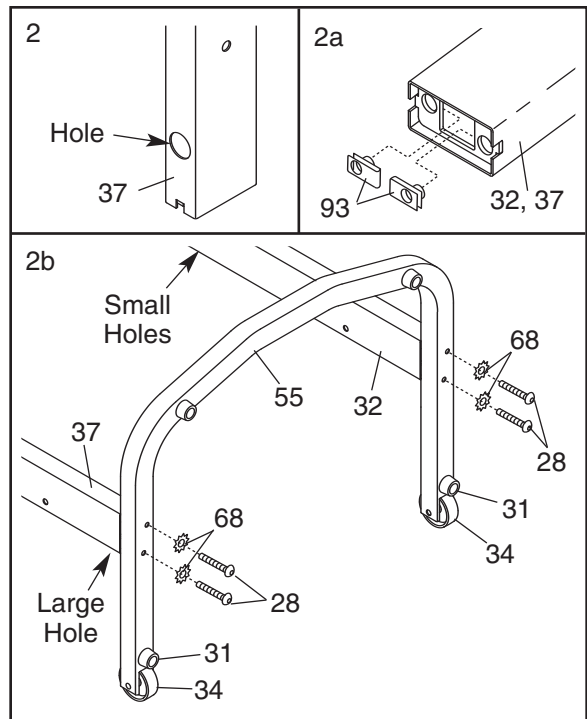

- With the help of a second person, place the Frame (21) between the Uprights (32, 37). Feed the Wire Harness (53) into the large round hole near the lower end of the Right Upright (37), and then pull the Wire Harness out of the upper end as shown.

See drawing 3a. Raise the Uprights (32, 37) to the vertical position. Hold an Upright Spacer (58) against one side of the Frame (21) as shown. Insert a Frame Bolt (36) into the indicated hole in the Upright Spacer and the Frame. Next, tighten a Spacer Screw (86) into the Upright Spacer and the Frame. **Remove the Frame Bolt.** Repeat on the other side of the Frame.

With the help of a second person, carefully lift the Frame (21), and hold the Upright Spacers (58) between the Right Upright (37) and the Left Upright (not shown). Align the indicated hole in the Right Upright with the hole in the right Upright Spacer. Insert a Frame Bolt (36), with a 3/8" Star Washer (90), into the Right Upright and the Upright Spacer, and loosely thread the Upright Bolt into the Frame. **Repeat this step on the left side of the treadmill.**

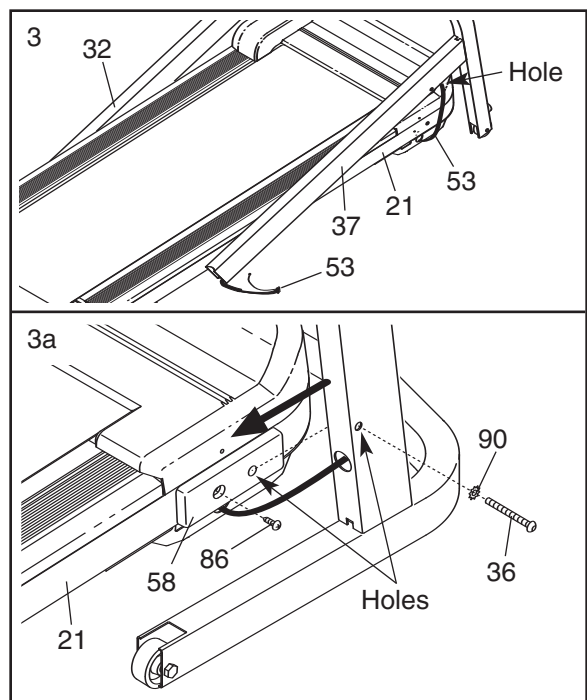

- With the help of a second person, tip the treadmill so the Base (not shown) is flat on the floor.

Insert the tab on one of the Handrail Brackets (40) into the slot in the Right Upright (37). Attach the Handrail Bracket with a 3/4" Screw (77); **be careful not to confuse the 3/4" Screws with the slightly larger Crossbar Screws (86, not shown).** Attach the other Handrail Bracket to the Left Upright (not shown) as described above.

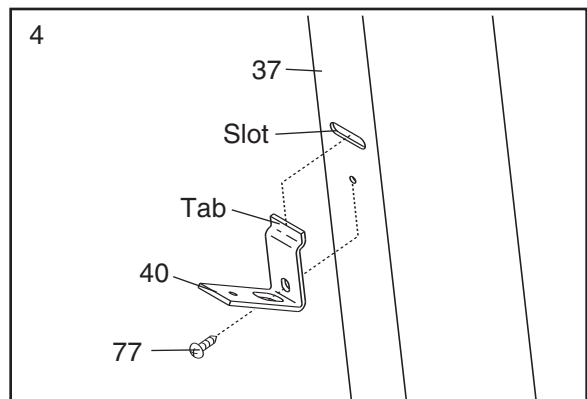

- Identify the Right Handrail (5), which has a large hole in the left side. Feed the Wire Harness (53) into the hole in the bottom of the Right Handrail and out of the large hole in the side. Note: It may be helpful to use needlenose pliers to pull the Wire Harness out of the hole.

Press a Handrail Cap (87) onto the lower end of the Right Handrail (5) as shown.

Set the Right Handrail (5) on the Right Upright (37), with the Handrail Bracket (40) inserted into the lower end of the Right Handrail.

Attach the Right Handrail (5) with an Upright Bolt (28) in the upper end and a 3/4" Screw (77) in the lower end. **Do not tighten the Upright Bolt until step 6 is completed.**

Attach the Left Handrail (4) as described above. Note: There is not a wire harness on the left side.

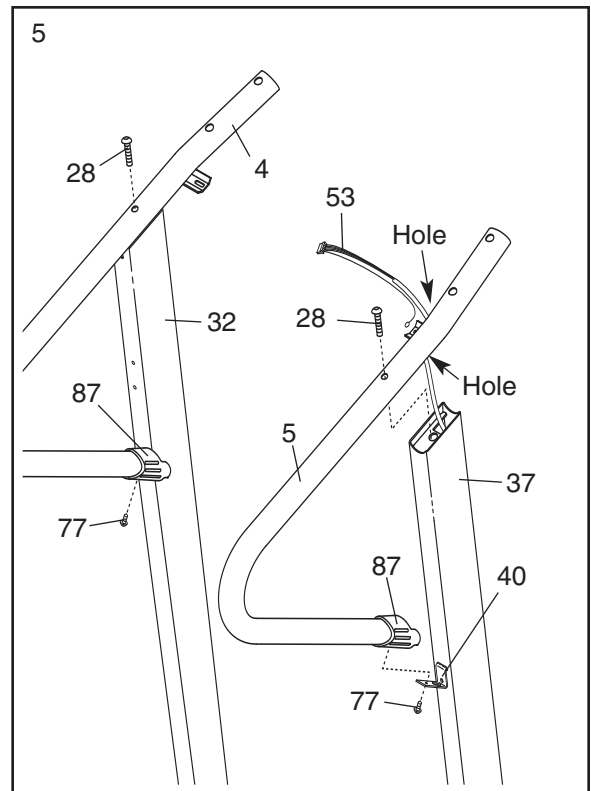

- See the inset drawings and identify the two Crossbar Screws (86); **be careful not to confuse the Crossbar Screws with the 3/4" Screws (77). The Crossbar Screws are slightly larger than the 3/4" Screws.**

Hold the Crossbar (65) on the small brackets on the Handrails (4, 5). Attach the Crossbar to the small brackets with the two Crossbar Screws (86). **Do not tighten the Crossbar Screws yet.**

Attach the end of the ground wire on the Wire Harness (53) to the small hole in the left side of the Right Handrail (5) with the Silver Ground Screw (89).

See step 5. Tighten the Upright Bolts (28).

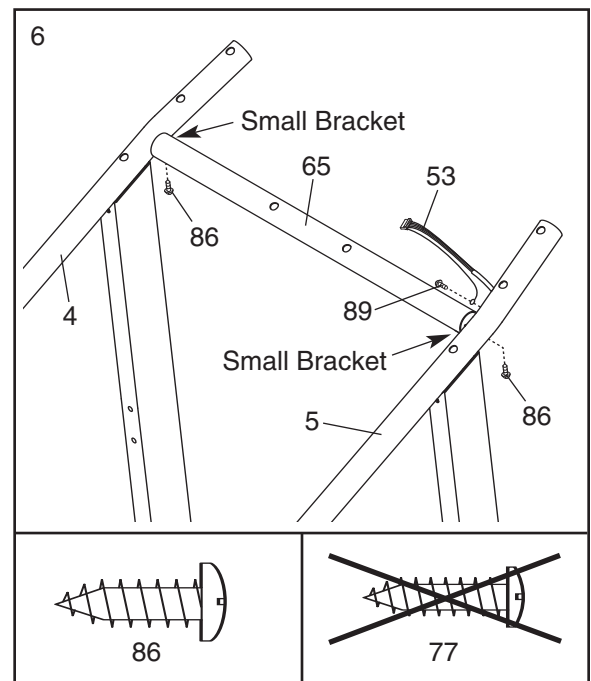

- Place the Console Base (45) on the Right Handrail (5) and the Left Handrail (not shown). Attach the Console Base with four 3/4" Screws (77) (only two Screws are shown). **Do not tighten the Screws yet.**

Insert the Wire Harness (53) through the two indicated plastic ties on the Console Base (45). Next, insert the Wire Harness up through the opening beside the Wire Cover (50). Make sure that the Wire Cover is securely attached to the Console Base.

See drawing 7a. Look at the top of the Console Base (45). Insert the Wire Harness (53) through the plastic tie on top of the Console Base.

Tighten the two Crossbar Screws (86) (only one is shown).

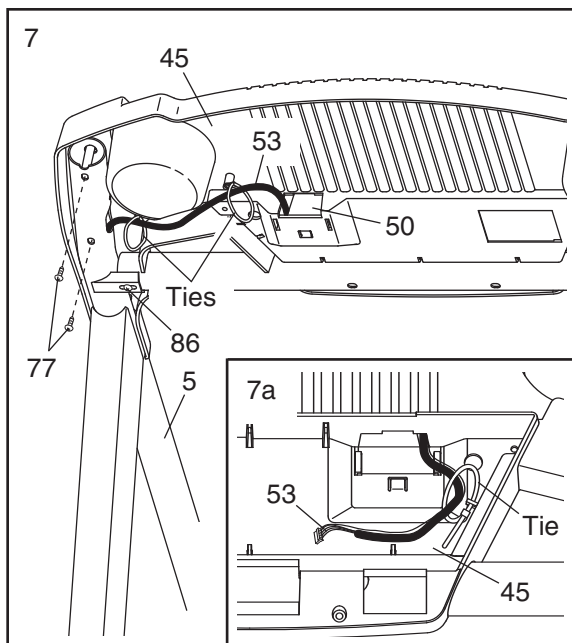

- Press the Book Rack (49) onto the Console Base (45) in the location shown.

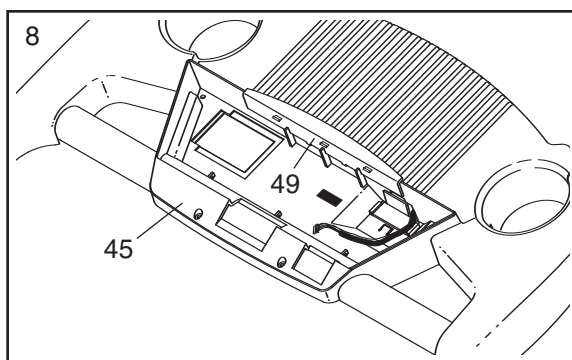

- Hold the Console (2) near the Console Base (45). **Touch the Right Handrail (5) to discharge any static.** Find the connector on the end of the Wire Harness (53). Insert the connector into the red socket beneath the Console. **The connector should slide easily into the socket and snap into place. If the connector does not slide easily and snap into place, turn the connector and then insert it.** Make sure that the connector and wires appear as shown in drawing 9a.

See drawing 7a. Insert the excess Wire Harness (53) down into the opening in the Console Base (45). **Securely tighten the plastic tie on top of the Console Base to prevent the Wire Harness from slipping.** Then, cut off the end of the plastic tie.

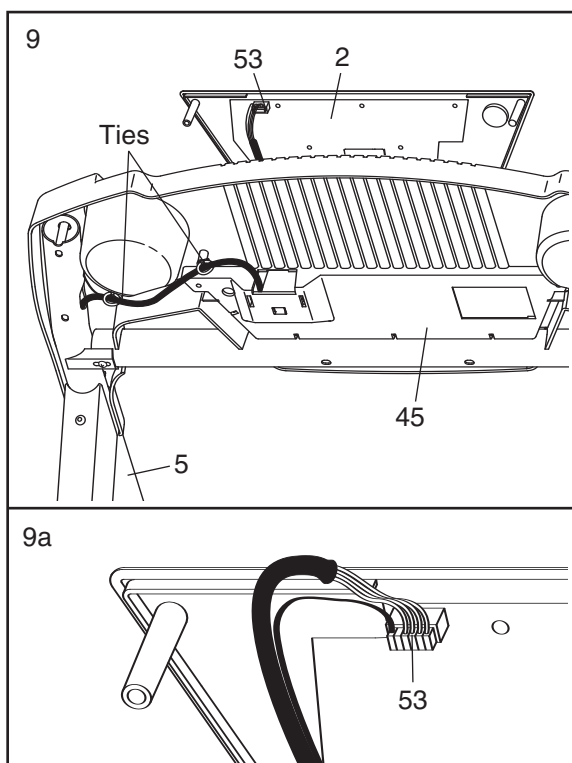

10. Set the Console (2) on the Console Base (45). Insert the excess Wire Harness (53) into the large hole in the side of the Right Handrail (5). **Securely tighten the plastic ties on the bottom of the Console Base to prevent the Wire Harness from slipping.** Then, cut off the ends of the plastic ties.

Attach the Console (2) to the Console Base (45) with four 3/4" Screws (77) and two 1/2" Screws (92). **Start all six Screws before tightening them; do not overtighten the Screws.**

See drawing 10a. Lower the Uprights (32, 37) until the Handrails (4, 5) are touching the floor. Position the Uprights so that the treadmill Frame (21) is centred between them. Firmly tighten the four Upright Bolts (28). Then, raise the Uprights back to the vertical position.

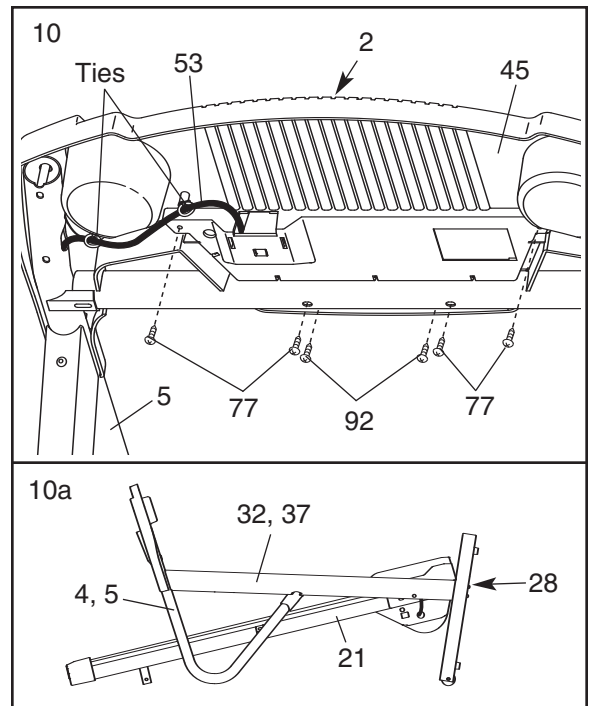

11. Attach the Latch Housing (25) and the Latch Spacer (99) to the Left Upright (32) with two 3/4" Screws (77). Next, remove the latch knob from the latch pin. Make sure that the collar and the spring are on the pin, and insert the pin into the Latch Housing. Then, tighten the knob back onto the pin.

Lift the treadmill frame to the storage position (see page 14). Make sure that the frame is centred between the Handrails (not shown). **Firmly tighten the bolts and screws used in assembly steps 3 through 7.**

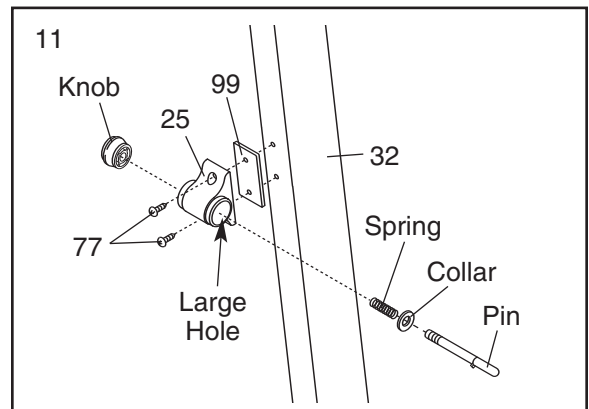

12. Insert one of the Incline Legs (47) into the right side of the Frame (21) as shown, and adjust the Incline Leg to the desired height. (Note: The Incline Leg can be adjusted to any of four positions to vary the intensity of your exercise.) Next, fully insert an Incline Pin (46) into the Frame and the Incline Leg, and turn the Incline Pin to the "locked" position shown in the inset drawing.

Insert the other Incline Leg (not shown) and Incline Pin (46) into the left side of the Frame (21) in the same way. **CAUTION: Before using the treadmill, make sure that both Incline Pins are fully inserted at the same height. In addition, make sure that both incline pins are inserted from the direction shown. Do not use the treadmill without the Incline Pins.**

Lower the treadmill (see HOW TO LOWER THE TREADMILL FOR USE on page 15).

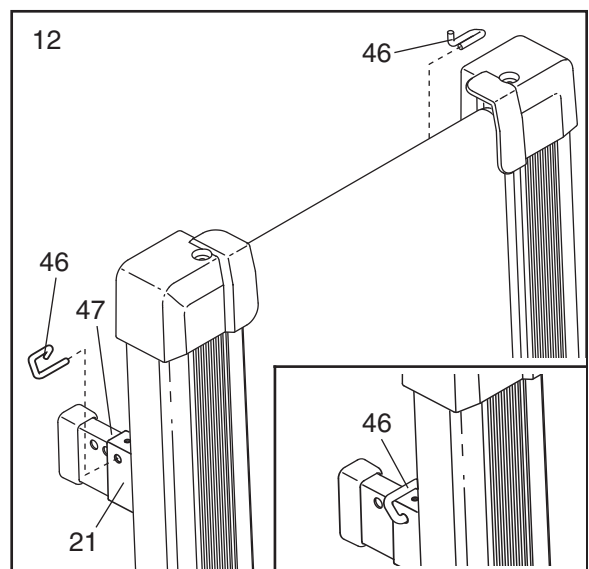

13. **Make sure that all parts are properly tightened before you use the treadmill.** Note: Extra hardware may be included. Keep the included hex keys in a secure place. The large hex key is used to adjust the walking belt (see page 17). To protect the floor or carpet, place a mat under the treadmill.

OPERATION AND ADJUSTMENT

THE PERFORMANT LUBE™ WALKING BELT

Your treadmill features a walking belt coated with PERFORMANT LUBE™, a high-performance lubricant. **IMPORTANT: Never apply silicone spray or other substances to the walking belt or the walking platform. Such substances will deteriorate the walking belt and cause excessive wear.**

HOW TO PLUG IN THE POWER CORD

This product must be earthed. If it should malfunction or break down, earthing provides a path of least resistance for electric current to reduce the risk of electric shock. This product is equipped with a power cord having an equipment-earthing conductor and an earthing plug. **Important: If the power cord is damaged, it must be replaced with a manufacturer-recommended power cord.**

See drawing 1. Plug the indicated end of the power cord into the socket on the treadmill.

See drawing 2. Press the pins on the power cord into the metal clips in the adapter as shown. Close the adapter cover over the end of the power cord and tighten the screw in the adapter. **Important: Make sure that the adapter cover is secure and the screw has been tightened before using the power cord.**

See drawing 3. Plug the power cord into an appropriate outlet that is properly installed and earthed in accordance with all local codes and ordinances. **Important: The treadmill is not compatible with GFCI-equipped outlets.**

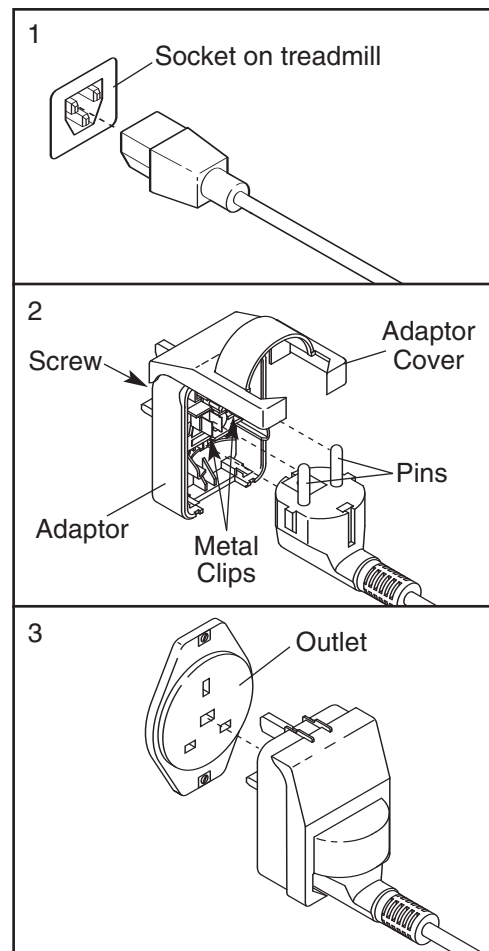

⚠ DANGER: Improper connection of the equipment-earthing conductor can result in an increased risk of electric shock. Check with a qualified electrician or serviceman if you are in doubt as to whether the product is properly earthed. Do not modify the plug provided with the product—if it will not fit the outlet, have a proper outlet installed by a qualified electrician.

CONSOLE DIAGRAM

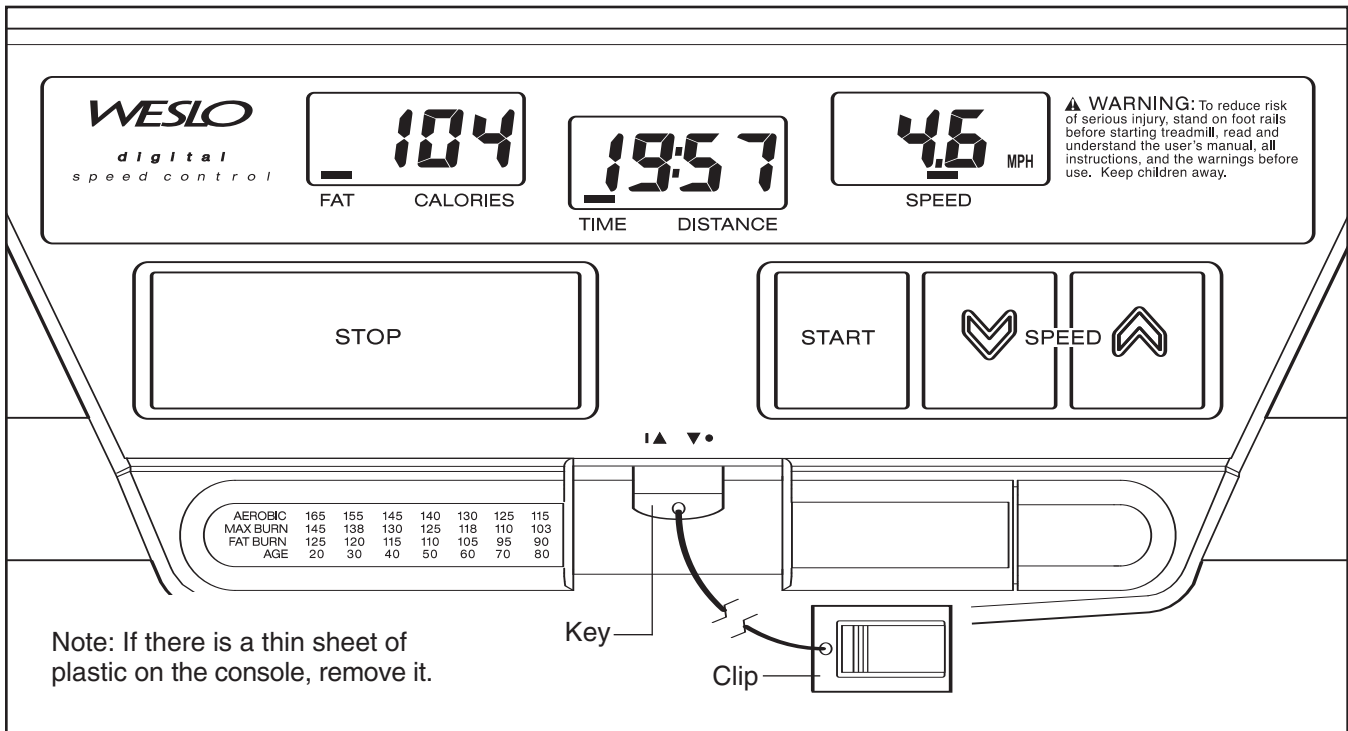

Note: If there is a thin sheet of plastic on the console, remove it.

CAUTION: Before operating the console, read the following precautions.

- Do not stand on the walking belt when turning on the power.
- Always wear the clip (see the drawing above) while operating the treadmill.
- Adjust the speed in small increments to avoid sudden jumps in speed.
- To reduce the possibility of electric shock, keep the console dry. Avoid spilling liquids on the console and place only a sealed water bottle in the water bottle holder.

STEP-BY-STEP CONSOLE OPERATION

Before operating the console, make sure that the power cord is properly plugged in (see page 11).

Next, locate the on/off switch on the side of the treadmill near the power cord. Move the on/off switch to the "on" position.



Stand on the foot rails of the treadmill. Find the clip attached to the key (see the drawing above), and slide

the clip onto the waistband of your clothes.

Next, insert the key fully into the console. After a moment, the displays will light. **Test the clip by carefully taking a few steps backward until the key is pulled from the console. If the key is not pulled from the console, adjust the position of the clip.**

Follow the steps below to operate the console.

1 Insert the key fully into the console.

A few seconds after the key is inserted, the displays will light.

2 Press the Start button or the Speed Δ button to start the walking belt.

A moment after the button is pressed, the walking belt will begin to move. Hold the handrails and begin walking.

As you exercise, change the speed of the walking belt as desired by pressing the Speed buttons. Each time a button is pressed, the speed setting will change by 0.1 mph; if a button is held down, the speed setting will change in increments of 0.5 mph. **Note: The console can display speed and distance in either miles or kilometres (see SPEED DISPLAY on page 13). For simplicity, all instructions in this section refer to miles.**

To stop the walking belt, press the Stop button. The elapsed time will begin to flash in the Time display.

Note: During the first few minutes that the treadmill is used, inspect the alignment of the walking belt, and align it if necessary (see page 17).

3 Follow your progress with the three displays.

Fat Calories/Calories display—This display shows the approximate numbers of *fat calories* and *calories* you have burned (see FAT BURNING on page 18). The display will change from one number to the other every few seconds, as shown by the mode indicators.

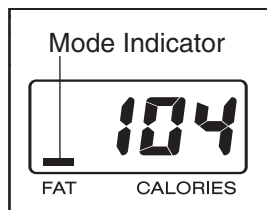

Time/Distance display—This display shows the elapsed time and the distance that you have walked or run. When the Stop button is pressed, the elapsed time will flash.

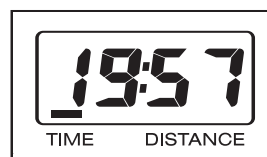

Speed display—This display shows the speed of the walking belt.



Note: The console can display speed and distance in either miles or kilometres. To change the unit of measurement, hold down the Stop button, insert the key into the console, and continue to hold the Stop button for a moment. An “E” for English miles or an “M” for metric kilometres will appear in the Fat Calories/Calories display. Press the Speed Δ button to change the unit of measurement. When the desired unit of measurement is selected, remove the key and then reinsert it.



To reset the displays, press the Stop button, remove the key, and then reinsert the key.

4 When you are finished exercising, remove the key.

Step onto the foot rails, press the Stop button, and remove the key from the console. Keep the key in

a secure place. Move the on/off switch near the power cord to the off position and unplug the power cord.

HOW TO CHANGE THE INCLINE OF THE TREADMILL

To vary the intensity of your exercise, the incline of the treadmill can be changed. There are four incline levels. **Before changing the incline, remove the key and unplug the power cord.**

Next, fold the treadmill to the storage position (see HOW TO FOLD THE TREADMILL FOR STORAGE on page 14).

To change the incline, remove the incline pin from the right incline leg as shown below. Adjust the incline leg to the desired height, and fully reinsert the incline pin. Make sure that the incline pin is in the “locked” position shown in the inset drawing. Adjust the left incline leg in the same way. **Make sure that both incline pins are inserted from the direction shown.**

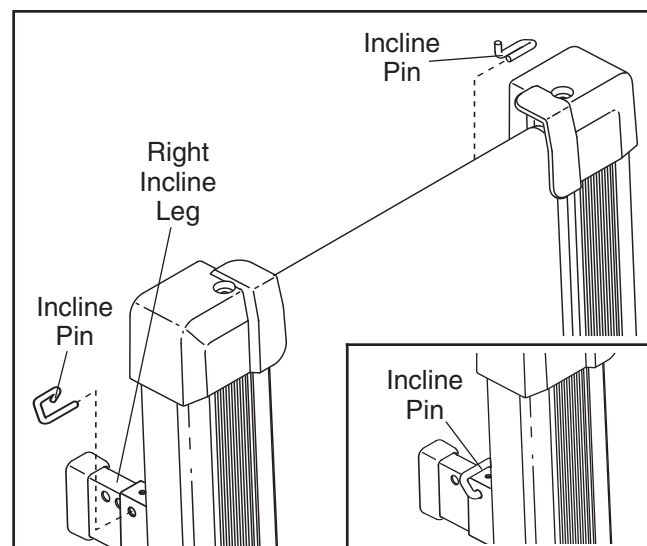

CAUTION: Before using the treadmill, make sure that both incline pins are fully inserted at the same height. Do not use the treadmill with the incline pins removed.

After you have adjusted the incline legs, lower the treadmill (see HOW TO LOWER THE TREADMILL FOR USE on page 15).

HOW TO FOLD AND MOVE THE TREADMILL

HOW TO FOLD THE TREADMILL FOR STORAGE

Unplug the power cord. **CAUTION:** You must be able to safely lift 20 kg (45 lbs.) to raise, lower, or move the treadmill.

1. Hold the treadmill with your hands in the locations shown at the right. **CAUTION: To decrease the possibility of injury, bend your legs and keep your back straight. As you raise the treadmill, make sure to lift with your legs rather than your back.** Raise the treadmill about halfway to the vertical position.

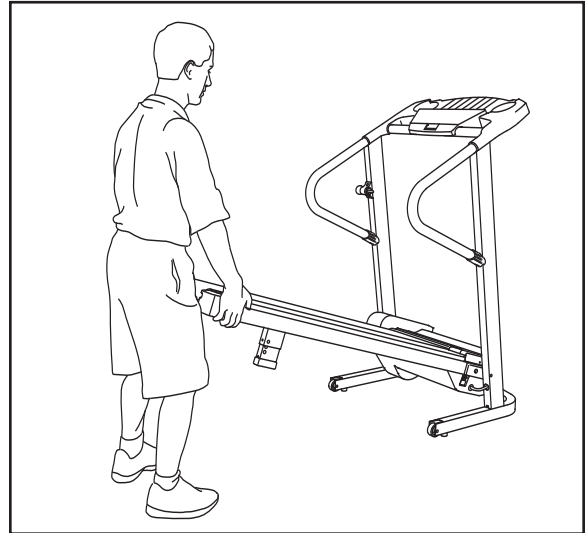

2. Move your right hand to the position shown and hold the treadmill firmly. Using your left hand, pull the latch knob to the left and hold it. Raise the treadmill until the frame passes the latch pin. Slowly release the latch knob. **Make sure that the frame is securely held by the latch pin.**

To protect the floor or carpet from damage, place a mat under the treadmill. Keep the treadmill out of direct sunlight. Do not leave the treadmill in the storage position in temperatures above 30° C (85° F).

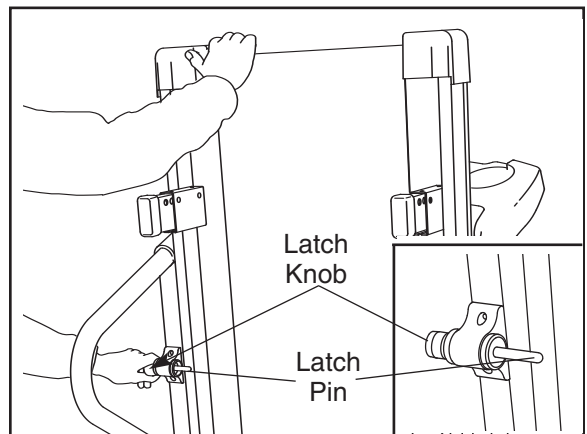

HOW TO MOVE THE TREADMILL

Before moving the treadmill, convert the treadmill to the storage position as described above. **Make sure that the latch pin is fully inserted into the hole in the handrail and locked into place as described above.**

1. Hold the handrails and place one foot on the base as shown.
2. Tilt the treadmill back until it rolls freely on the front wheels. Carefully move the treadmill to the desired location. **Never move the treadmill without tipping it back. To reduce the risk of injury, use extreme caution whilst moving the treadmill. Do not attempt to move the treadmill over an uneven surface.**
3. Place one foot on the base, and carefully lower the treadmill until it is resting in the storage position.

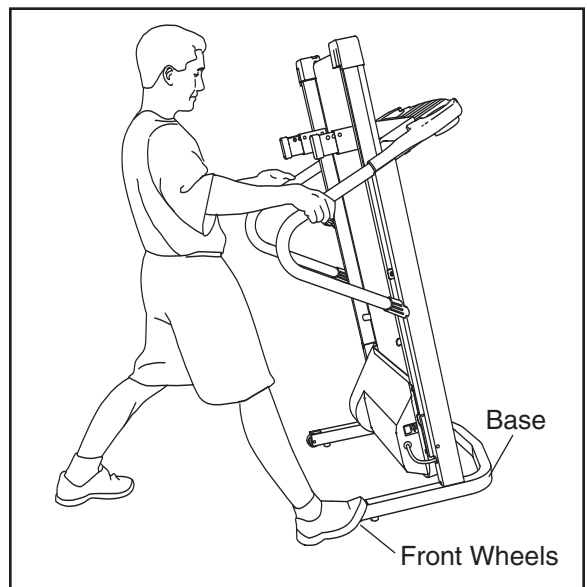

HOW TO LOWER THE TREADMILL FOR USE

1. Hold the upper end of the treadmill with your right hand as shown. Using your left hand, pull the latch knob to the left and hold it. Pivot the treadmill down until the frame is past the latch pin. Slowly release the latch knob.

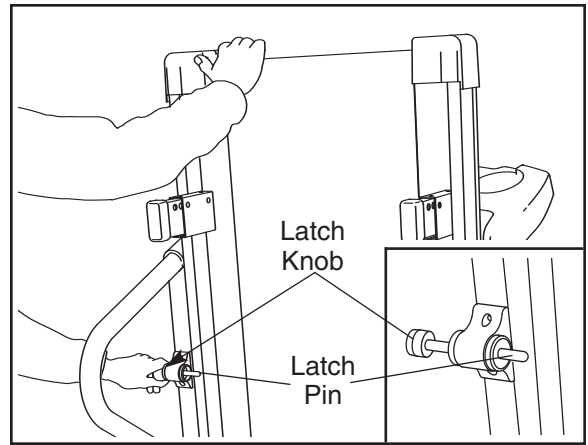

2. Hold the treadmill firmly with both hands, and lower the treadmill to the floor. **To decrease the possibility of injury, bend your legs and keep your back straight.**

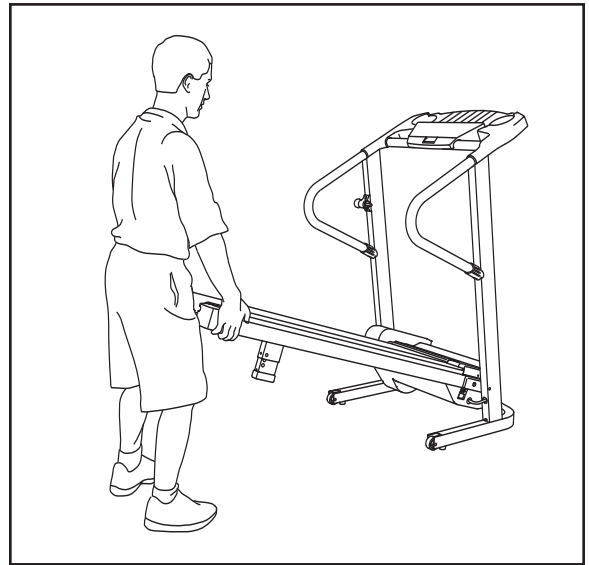

MAINTENANCE AND TROUBLESHOOTING

Most treadmill problems can be solved by following the steps below. Find the symptom that applies, and follow the steps listed. If further assistance is needed, please call our Customer Service Department.

PROBLEM: The power does not turn on

SOLUTION: a. Make sure that the power cord is plugged into a properly earthed outlet. (See page 11.) If an extension cord is needed, use only a 3-conductor, 1mm² (14-gauge) cord that is no longer than 1.5 m (5 ft.). **IMPORTANT: The treadmill is not compatible with GFCI-equipped outlets.**

b. After the power cord has been plugged in, make sure that the key is fully inserted into the console.

c. Check the circuit breaker located on the treadmill near the power cord. If the switch protrudes as shown, the circuit breaker has tripped. To reset the circuit breaker, wait for five minutes and then press the switch back in.

c. Check the on/off switch located on the frame near the power cord. The switch must be in the on position.

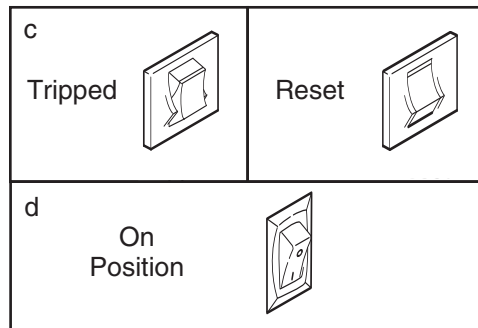

PROBLEM: The power turns off during use

SOLUTION: a. Check the circuit breaker located on the treadmill frame near the power cord (see c. above). If the circuit breaker has tripped, wait for five minutes and then press the switch back in.

b. Make sure that the power cord is plugged in. If the power cord is plugged in, unplug it, wait for five minutes, and then plug it back in.

c. Remove the key from the console. Reinsert the key fully into the console.

d. Make sure that the on/off switch is in the on position (see d. above).

e. If the treadmill still will not run, please call our Customer Service Department.

PROBLEM: The displays of the console do not function properly

SOLUTION: a. Remove the key from the console and **UNPLUG THE POWER CORD**. Remove the screws from the hood, and carefully remove the hood.

Locate the Reed Switch (8) and the Magnet (14) on the left side of the Pulley (17). Turn the Pulley until the Magnet is aligned with the Reed Switch. **Make sure that the gap between the Magnet and the Reed Switch is about 3 mm (1/8 in.).** If necessary, loosen the Screw (56), move the Reed Switch slightly, and then retighten the Screw. Reattach the hood, and run the treadmill for a few minutes to check for a correct speed reading

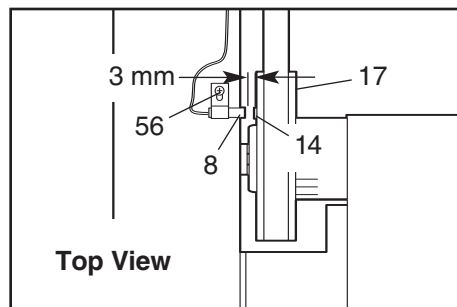

PROBLEM: The walking belt slows when walked on

SOLUTION: a. If an extension cord is needed, use only a 3-conductor, 1mm² (14-gauge) cord that is no longer than 1.5 m (5 ft.).

b. If the walking belt is overtightened, treadmill performance may decrease and the walking belt may become damaged. Remove the key and **UNPLUG THE POWER CORD**. Using the hex key, turn both rear roller bolts counterclockwise, 1/4 of a turn. When the walking belt is properly tightened, you should be able to lift each side of the walking belt 5 to 7 cm (2 to 3 in.) off the walking platform. Be careful to keep the walking belt centred. Plug in the power cord, insert the key and run the treadmill for a few minutes. Repeat until the walking belt is properly tightened.

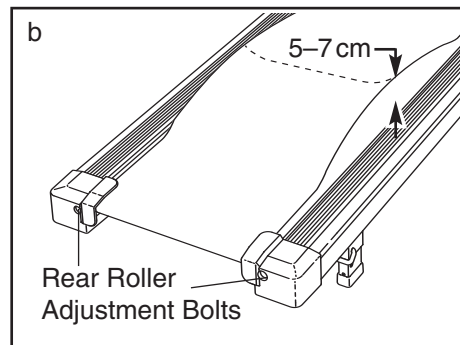

c. If the walking belt still slows when walked on, please call our Customer Service Department.

PROBLEM: The walking belt is off-centre or slips when walked on

SOLUTION: a. If the walking belt is off-centre, first remove the key and **UNPLUG THE POWER CORD**. **If the walking belt has shifted to the left**, use the hex key to turn the left rear roller bolt clockwise 1/2 of a turn; **if the walking belt has shifted to the right**, turn the bolt counterclockwise 1/2 of a turn. Be careful not to overtighten the walking belt. Plug in the power cord, insert the key, and run the treadmill for a few minutes. Repeat until the walking belt is centred.

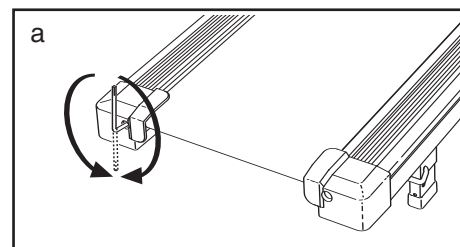

b. If the walking belt slips when walked on, first remove the key and **UNPLUG THE POWER CORD**. Using the hex key, turn both rear roller bolts clockwise, 1/4 of a turn. When the walking belt is correctly tightened, you should be able to lift each side of the walking belt 5 to 7 cm (2 to 3 in.) off the walking platform. Be careful to keep the walking belt centred. Plug in the power cord, insert the key, and walk on the treadmill for a few minutes. Repeat until the walking belt is properly tightened.

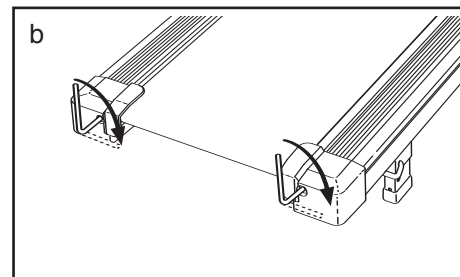

CONDITIONING GUIDELINES

⚠ WARNING: Before beginning this or any exercise program, consult your physician. This is especially important for individuals over the age of 35 or individuals with pre-existing health problems.

The following guidelines will help you to plan your exercise program. For more detailed exercise information, obtain a reputable book or consult your physician.

EXERCISE INTENSITY

Whether your goal is to burn fat or to strengthen your cardiovascular system, the key to achieving the desired results is to exercise with the proper intensity. The proper intensity level can be found by using your heart rate as a guide. The chart below shows recommended heart rates for fat burning and aerobic exercise.

HEART RATE TRAINING ZONES								
AGE	20	30	40	50	60	70	80	
MAX	165	155	145	140	130	125	115	
bpm	145	138	130	125	118	110	103	
MIN	125	120	115	110	105	95	90	

To find the proper heart rate for you, first find your age at the top of the chart (ages are rounded off to the nearest ten years). Next, find the three numbers below your age. The three numbers are your “training zone.” The lower two numbers are recommended heart rates for fat burning; the highest number is the recommended heart rate for aerobic exercise.

Fat Burning

To burn fat effectively, you must exercise at a relatively low intensity level for a sustained period of time. During the first few minutes of exercise, your body uses easily accessible *carbohydrate calories* for energy. Only after the first few minutes does your body begin to use stored *fat calories* for energy. If your goal is to burn fat, adjust the speed and incline of the treadmill until your heart rate is near one of the lower two numbers in your training zone.

Aerobic Exercise

If your goal is to strengthen your cardiovascular system, your exercise must be “aerobic.” Aerobic exercise is activity that requires large amounts of oxygen for prolonged periods of time. This increases the demand on the heart to pump blood to the muscles, and on the lungs to oxygenate the blood. For aerobic exercise, adjust the speed and incline of the treadmill until your heart rate is near the highest number in your training zone.

HOW TO MEASURE YOUR HEART RATE

To measure your heart rate, stop exercising and place two fingers on your wrist as shown. Take a six-second heartbeat count, and multiply the result by ten to find your heart rate.

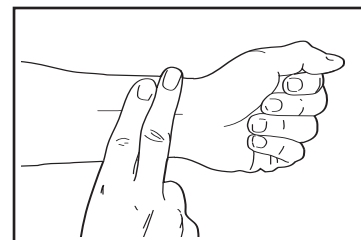

(A six-second count is used because your heart rate drops quickly when you stop exercising.) If your heart rate is too high or too low, adjust the speed or incline of the treadmill accordingly.

WORKOUT GUIDELINES

Each workout should include the following three important parts:

A Warm-up

Warming up prepares the body for exercise by increasing circulation, delivering more oxygen to the muscles and raising the body temperature. Begin each workout with 5 to 10 minutes of stretching and light exercise to warm up (see SUGGESTED STRETCHES on page 19).

Training Zone Exercise

After warming up, increase the intensity of your exercise until your pulse is in your training zone for 20 to 60 minutes. (During the first few weeks of your exercise program, do not keep your pulse in your training zone for longer than 20 minutes.) Breathe regularly and deeply as you exercise—never hold your breath.

A Cool-down

Finish each workout with 5 to 10 minutes of stretching to cool down. This will increase the flexibility of your muscles and will help to prevent post-exercise problems.

EXERCISE FREQUENCY

To maintain or improve your condition, complete three workouts each week, with at least one day of rest be-

tween workouts. After a few months, you may complete up to five workouts each week if desired. The key to success is to make exercise a regular and enjoyable part of your everyday life.

SUGGESTED STRETCHES

The correct form for several basic stretches is shown at the right. Move slowly as you stretch—never bounce.

1. Toe Touch Stretch

Stand with your knees bent slightly and slowly bend forward from your hips. Allow your back and shoulders to relax as you reach down toward your toes as far as possible. Hold for 15 counts, then relax. Repeat 3 times. Stretches: Hamstrings, back of knees, and back.

2. Hamstring Stretch

Sit with one leg extended. Bring the sole of the opposite foot toward you and rest it against the inner thigh of your extended leg. Reach toward your toes as far as possible. Hold for 15 counts, then relax. Repeat 3 times for each leg. Stretches: Hamstrings, lower back, and groin.

3. Calf/Achilles Stretch

With one leg in front of the other, reach forward and place your hands against a wall. Keep your back leg straight and your back foot flat on the floor. Bend your front leg, lean forward and move your hips toward the wall. Hold for 15 counts, then relax. Repeat 3 times for each leg. To cause further stretching of the achilles tendons, bend your back leg as well. Stretches: Calves, achilles tendons, and ankles.

4. Quadriceps Stretch

With one hand against a wall for balance, reach back and grasp one foot with your other hand. Bring your heel as close to your buttocks as possible. Hold for 15 counts, then relax. Repeat 3 times for both legs. Stretches: Quadriceps and hip muscles.

5. Inner Thigh Stretch

Sit with the soles of your feet together and your knees outward. Pull your feet toward your groin area as far as possible. Hold for 15 counts, then relax. Repeat 3 times. Stretches: Quadriceps and hip muscles.

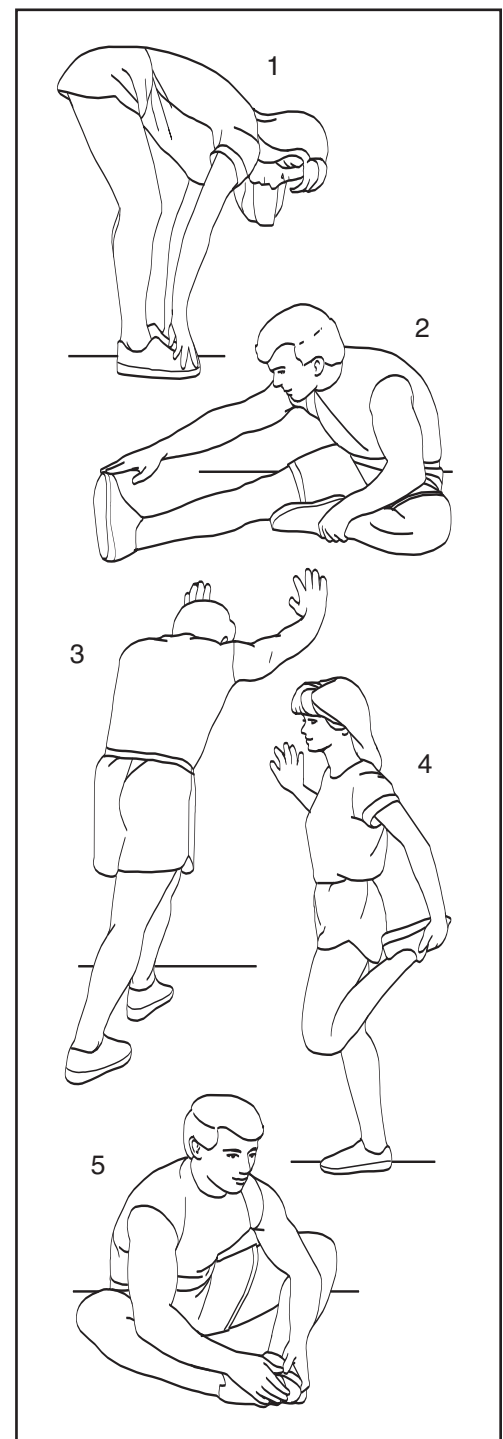

NOTES

PART LIST—Model No. WETL1214.0

R0305A

Key No.	Qty.	Description			
			57	1	Belly Pan
			58	2	Upright Spacer
1	1	Hood	59	1	Motor Tension Washer
2	1	Console	60	1	Left Foot Rail
3	1	Motor Belt	61	2	Wheel Nut
4	1	Left Handrail	62	2	Belt Guide
5	1	Right Handrail	63	1	Motor Nut
6	1	Motor Isolator	64	1	Right Foot Rail
7	1	Motor	65	1	Crossbar
8	1	Reed Switch	66	1	Latch Catch
9	9	Electronics Screw	67	2	Incline Leg Endcap
10	1	Reed Switch Clip	68	4	5/16" Star Washer
11	4	1" Tek Screw	69	1	Right Endcap
12	2	Hood Anchor	70	2	Rear Roller Adj. Bolt
13	2	Front Roller Bolt	71	11	Small Washers
14	1	Magnet	72	1	Rear Roller
15	6	Platform Screw	73	1	Ground Wire
16	1	Motor Tension Nut	74	1	Walking Platform
17	1	Front Roller/Pulley	75	1	Walking Belt
18	1	Motor Tension Bolt	76	1	Releaseable Tie
19	1	Circuit Breaker	77	12	3/4" Screw
20	1	Reed Switch Bracket	78	2	Cable Tie Clamp
21	1	Frame	79	4	8" Cable Tie
22	1	Receptical	80	3	Motor Star Washer
23	1	Controller	81	2	Front Roller Nut
24	1	Motor Pivot Bolt	82	2	Incline Washer
25	1	Latch Housing	83	1	Left Endcap
26	1	Choke	84	1	Motor Pivot Sleeve
27	1	Electronics Bracket	85	2	Motor Pivot Bushing
28	6	Upright Bolt	86	4	Crossbar Screw/Spacer Screw
29	1	Motor Bracket	87	2	Handrail Cap
30	1	Power Cord	88	4	3/8" Washer
31	4	Base Pad	89	1	Silver Ground Screw
32	1	Left Upright	90	2	3/8" Star Washer
33	2	Wheel Bolt	91	4	Hood Screw
34	2	Wheel	92	2	1/2" Screw
35	1	Allen Wrench	93	4	U-nut
36	2	Frame Bolt	94	1	Warning Decal
37	1	Right Upright	95	2	Hood Bracket
38	1	Storage Latch	96	1	Power Cord Adaptor
39	4	Handrail Washer	97*	1	Motor Assembly
40	2	Handrail Bracket	98	1	Belly Pan Grommet
41	4	Cage Nut	99	1	Latch Spacer
42	1	Key/Clip	100	2	Motor Bolt
43	1	Latch Decal	101	1	Flywheel
44	1	Filter	102	1	Power Switch
45	1	Console Base	103	1	Ferrite Box
46	2	Incline Pin	#	1	6" Blue Wire, 2 Female
47	2	Incline Leg	#	1	4" Blue Wire, 2 Female
48	1	Console Cover	#	1	8" White Wire Harness, 2 Female
49	1	Book Rack	#	1	6" White Wire, 2 Female
50	1	Wire Cover	#	1	8" Green/Yellow Wire, F/Ring
51	1	1/2" Screw	#	1	6" Green/Yellow Wire, F/Ring
52	4	Belt Guide Screw	#	1	4" Black Wire, 2 Female
53	1	Wire Harness	#	1	User's Manual
54	1	Grommet			
55	1	Base			
56	20	3/4" Tek Screw			

*Includes all parts shown in the box
 "#" indicates a non-illustrated part

EXPLODED DRAWING—Model No. WETL1214.0

R0305A

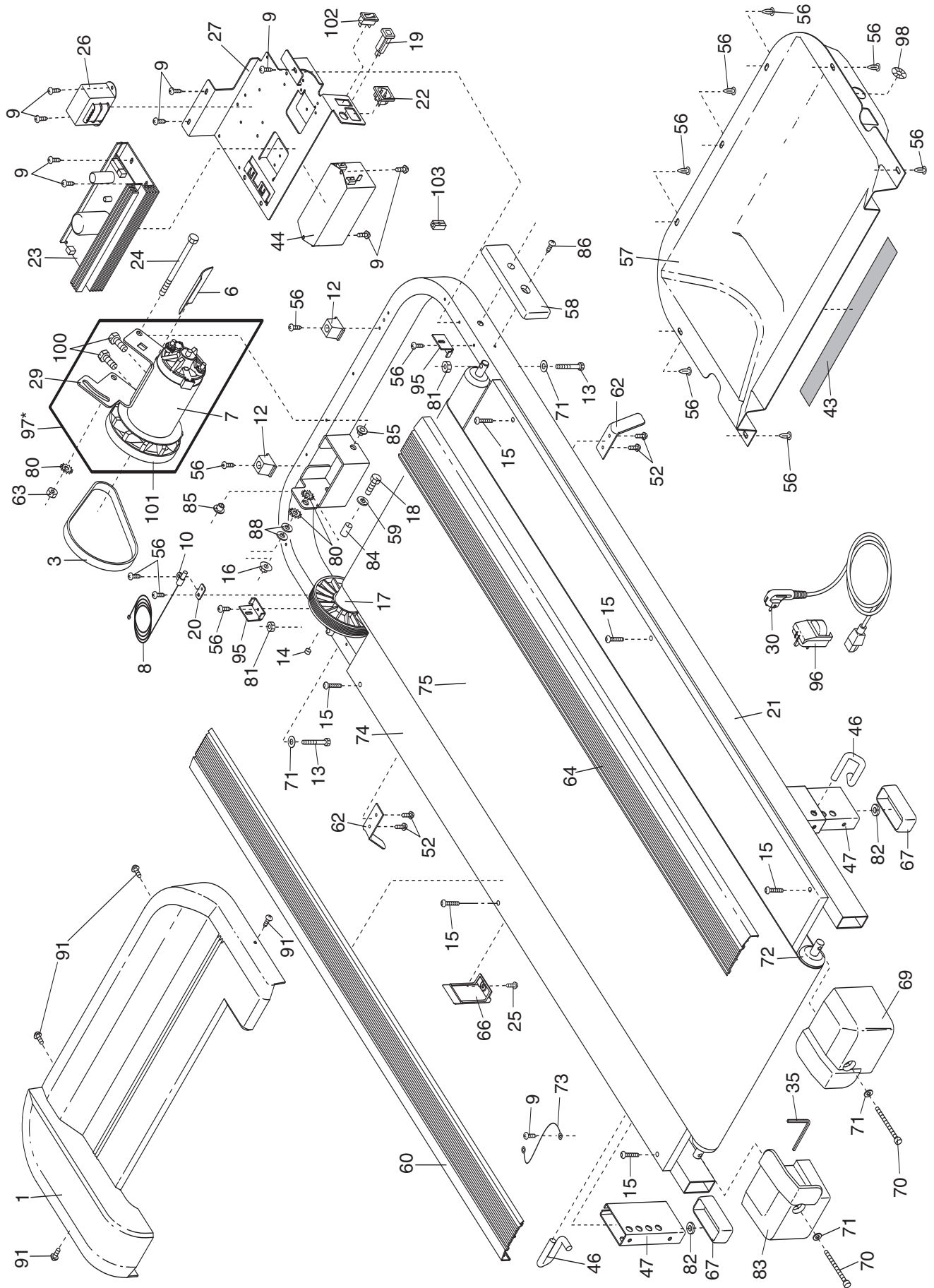

EXPLODED DRAWING—Model No. WETL1214.0

R0305A

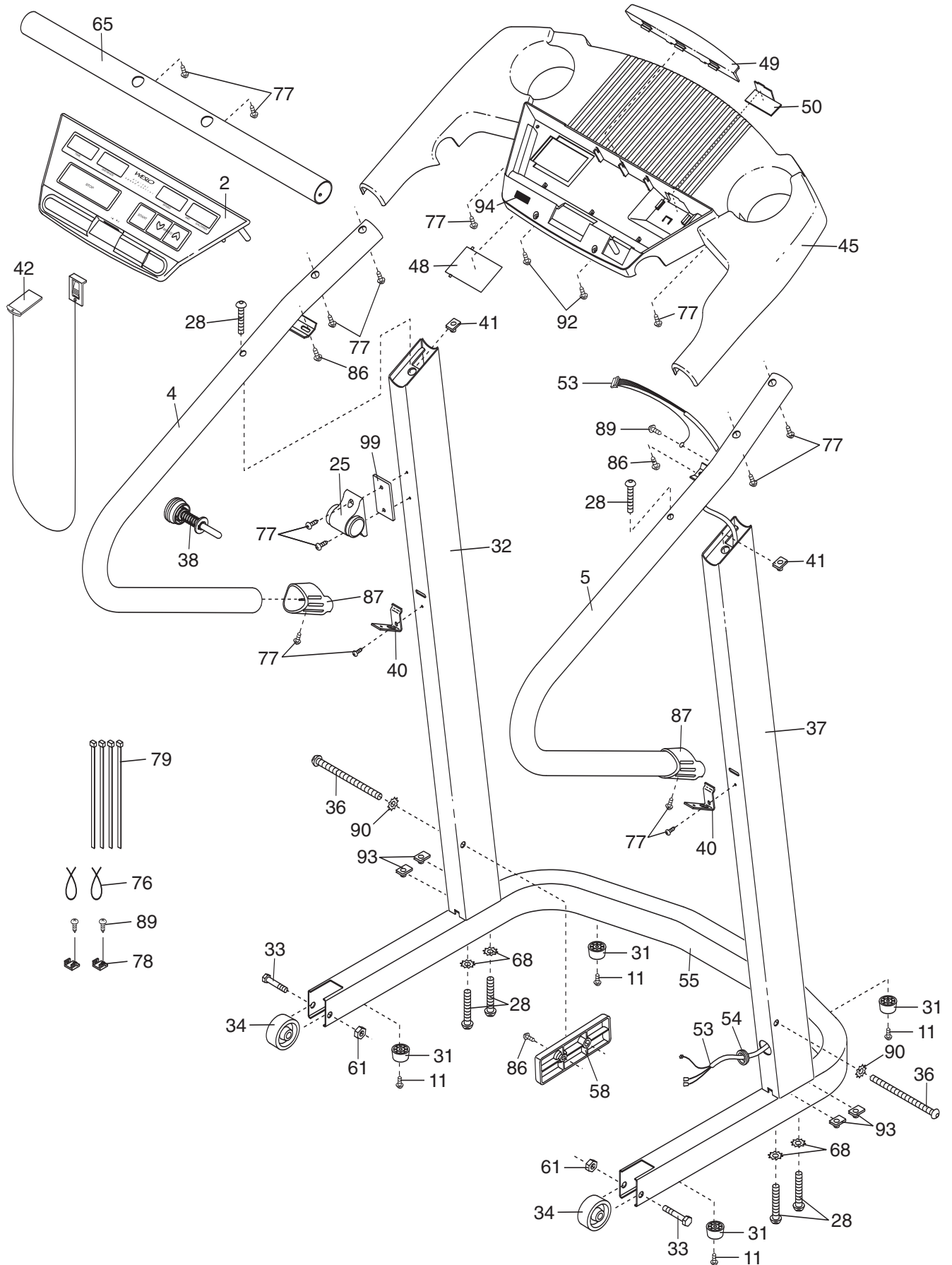

ORDERING REPLACEMENT PARTS

If you encounter any problems with this product, or if you need to order replacement parts, contact the ICON Health & Fitness, Ltd. office, or write:

ICON Health & Fitness, Ltd.
Customer Service Department
Unit 4, Revie Road Industrial Estate
Beeston
Leeds, LS11 8JG
UK

Tel:

08457 089 009

Outside the UK: 0 (044) 113 387 7133
Fax: 0 (044) 113 387 7125

When ordering parts, please be prepared to give the following information:

- the MODEL NUMBER of the product (WETL1214.0)
- the NAME of the product (WESLO SPORT 100 treadmill)
- the SERIAL NUMBER of the product (see the front cover of this manual)
- the KEY NUMBER and DESCRIPTION of the part(s) (see the PART LIST and the EXPLODED DRAWING on pages 21 to 23)