

TECHNICAL DATA SHEET - 32" - 50" Flat Panel TV Stand

peerless[®]
Solid Solutions - Solid Support™

SS550P, SS550P-S

Flat Panel Stand for 32" to 50" screens provides tilt and vertical adjustment features to achieve the ideal viewing angle. Centralized A/V component and accessory placement is easy with adjustable glass shelves and a triangular base. Designed to hide all cords and cables its internal management system offers a clean, clutter-free appearance.



This product is UL Listed. It must be installed by a qualified professional installer.

Features:

- Colors: Black with clear glass shelves or Silver with clear glass shelves.
- Holds flat panel screens from 32" to 50"
- Screens provide tilt and vertical adjustment features to achieve the ideal viewing angle
- Incremental tilt of -2°, 0° and +5° makes it easy to simply adjust
- Internal cable management neatly hides all cords and cables for a clean, clutter-free look
- 250 lb maximum weight capacity (150 lb for screen; 50 lb per shelf)
- Dimensions: 61"H (including screen brackets) x 40.5"W x 25.6"D
- Ships ready-to-assemble

Dimensions:

Weight:

79 lb (35.8 kg)

Shipping weight:

95 lb (43.1 kg)

Max Load Capacity:

150 lb (68 kg) screen

50 lb (22.7 kg) per shelf

Shipping Carton dimensions:

L= 57.5 in. (1458 mm)

W= 27.5 in. (696 mm)

H= 6.75 in. (172 mm)

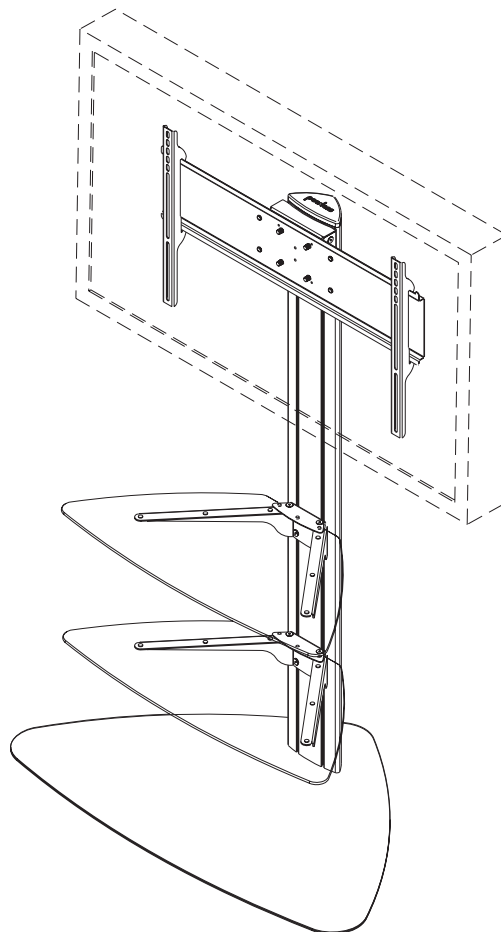

ARCHITECTS SPECIFICATIONS

32" - 50" Flat Panel TV Stand shall be a Peerless model **SS550P, SS550P-S** and shall be installed where indicated on the plans. It shall be constructed of heavy gauge cold rolled steel and finished with scratch resistant Black or Silver Fused Epoxy. Assembly and installation shall be done according to instructions provided by the manufacturer.

Peerless Industries, Inc.

3215 W. North Ave. Melrose Park, IL 60160
708-865-8870 800-865-2112 Fax 708-865-2941

www.peerlessmounts.com

ISSUED: 09-14-06 SHEET NO: 202-9544-3 01-23-07

©2007 Peerless Industries, Inc. All rights reserved.
Peerless is a registered trademark of Peerless Industries, Inc.

All other brand and product names are trademarks or registered trademarks of their respective owners.

TECHNICAL DATA SHEET

MODEL: SS550P, SS550P-S

ALL DIMENSION = INCH
(MM)

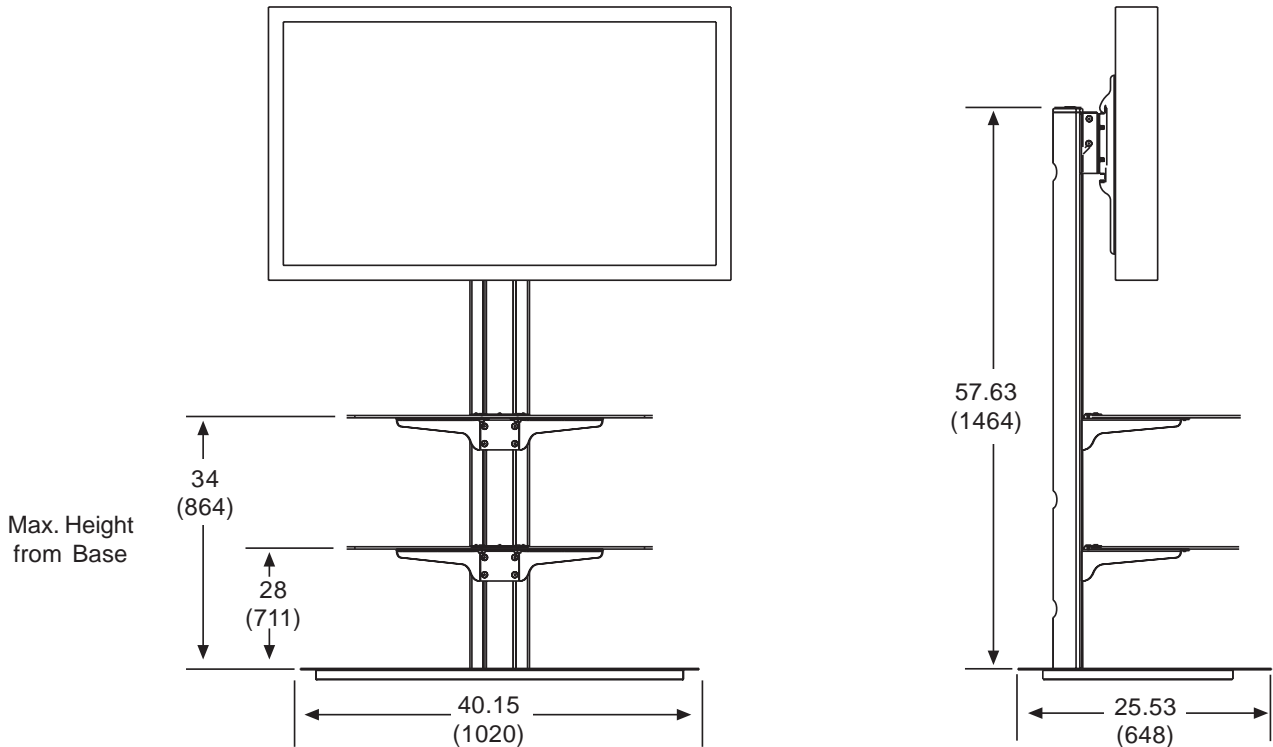

Front View

Side View

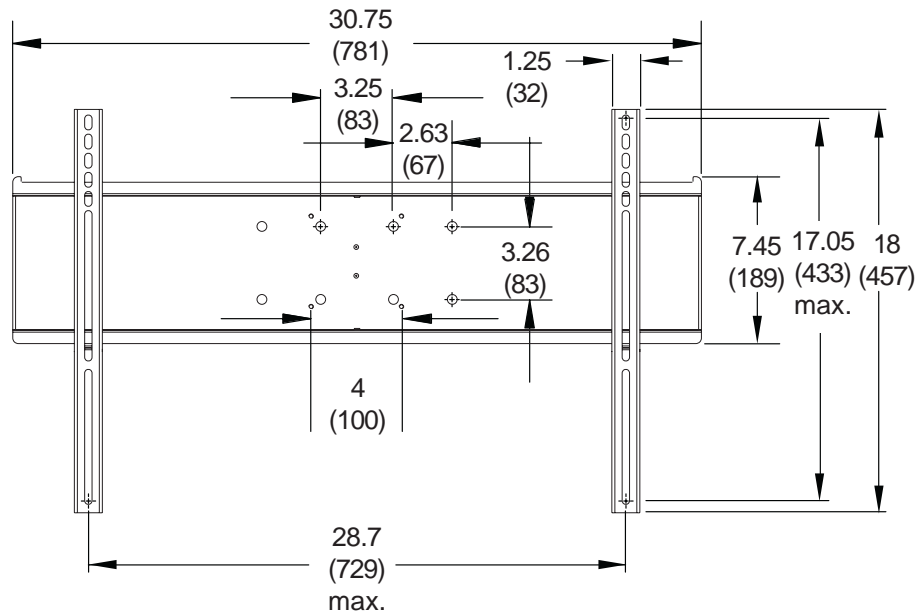

Adapter Bracket Detail