

A.O. SMITH

FEATURES

MEETS ASHRAE/IES 90.1b-1992 REQUIREMENTS FOR IMPROVED ENERGY EFFICIENCIES.

LIME TAMER™ MODELS INHIBIT LIME AND SEDIMENT BUILDUP— Lime Tamer™ models are warranted against tank failure due to sediment buildup for three years.

GLASS-LINED TANK— Assures years of rust-free clean hot water. 160 psi working pressure.

180° ADJUSTABLE THERMOSTAT— Has upper and lower sensing bulbs to average water temperatures at top and bottom of heater for maximum temperature control (120°-180°).

SAFETY SHUTOFF— Limits temperature buildup.

UL LISTED OIL BURNER— Precision engineered to match each unit; designed to fire 1.75 to 5.0 gallons of oil per hour. All models equipped with single phase continuous duty motor 120 volt AC 60 Hz, 3450 rpm with manual overload switch and interrupted ignition. Standard burners equipped with single stage pump with 1 or 2 line capability. Flame retention principle assures high rate of combustion efficiency, yet maintains low operating noise levels. Fuel unit includes pump, strainer, pressure regulating valve and ignition transformer. Transformer rated at 120 volt AC, 60 Hz with 10,000 volt secondary, UL listed for use with No. 1 and 2 commercial grade fuel oil. Burner mounted cadmium cell relay for flame detection - 15 second safety switch timing eliminates the need for RA890F Electronic Safeguard. Complies with UL A708.5-32/33.

EFFICIENT COMBUSTION CHAMBER— Precast, high temperature combustion chamber made of alumina silica ceramic fiber. Engineered for maximum insulation and heat reflection. Unique design assures more complete combustion by stabilizing flame pattern.

OIL SOLENOID SAFETY VALVE— Standard on COF-455 and 700.

3/4" DRAIN VALVE— Provided in lower tank for fast draining.

HAND-HOLE CLEANOUTS— Allows easy cleaning. Two standard on models COF-385 and larger and ASME models.

ANODIC PROTECTION— For longer tank life.

FLAME OBSERVATION PORT— Permits convenient flame check.

FOAM INSULATION— Saves fuel, helps assure constant temperature, verminproof.

JACKET— Heavy gauge steel with baked enamel finish over bonderized undercoat.

EASY TO INSTALL BURNER— Three bolt mounting of burner assures easy installation and proper alignment.

BAROMETRIC DRAFT REGULATOR

FACTORY INSTALLED CGA RATED T&P VALVE

OPTIONAL

Two Stage Pump— For use with underground oil storage tanks or JP-5 fuel.

Oil Solenoid Safety Valve— Optional on COF-199, 245, 315 and 385.

ASME Construction Available— On models COF-315A and larger. ASME units have 160 psi working pressure.

CAUTION: Units must be installed on noncombustible surface.

CONSERVATIONIST®

DURACLAD

COMMERCIAL OIL-FIRED WATER HEATERS

COF-199 THRU COF-700

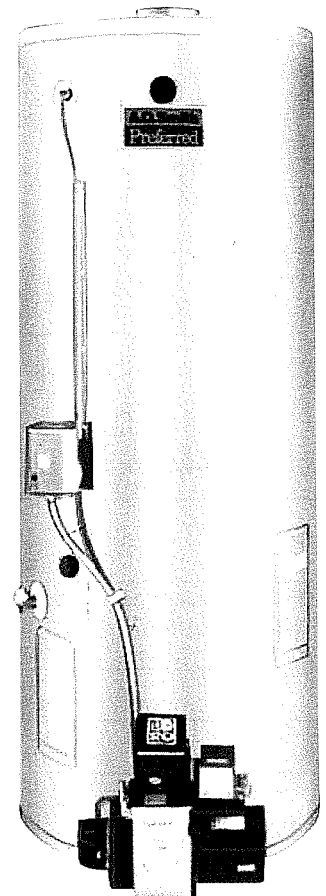

ASME
(OPTIONAL)



LIMITED WARRANTY OUTLINE

If the tank should leak anytime during the first three years, under the terms of the warranty, A.O. Smith will furnish a replacement heater less burner and controls; installation, labor, handling and local delivery extra.

THIS OUTLINE IS NOT A WARRANTY. For complete information, consult the written warranty or A.O. Smith Water Products Company.

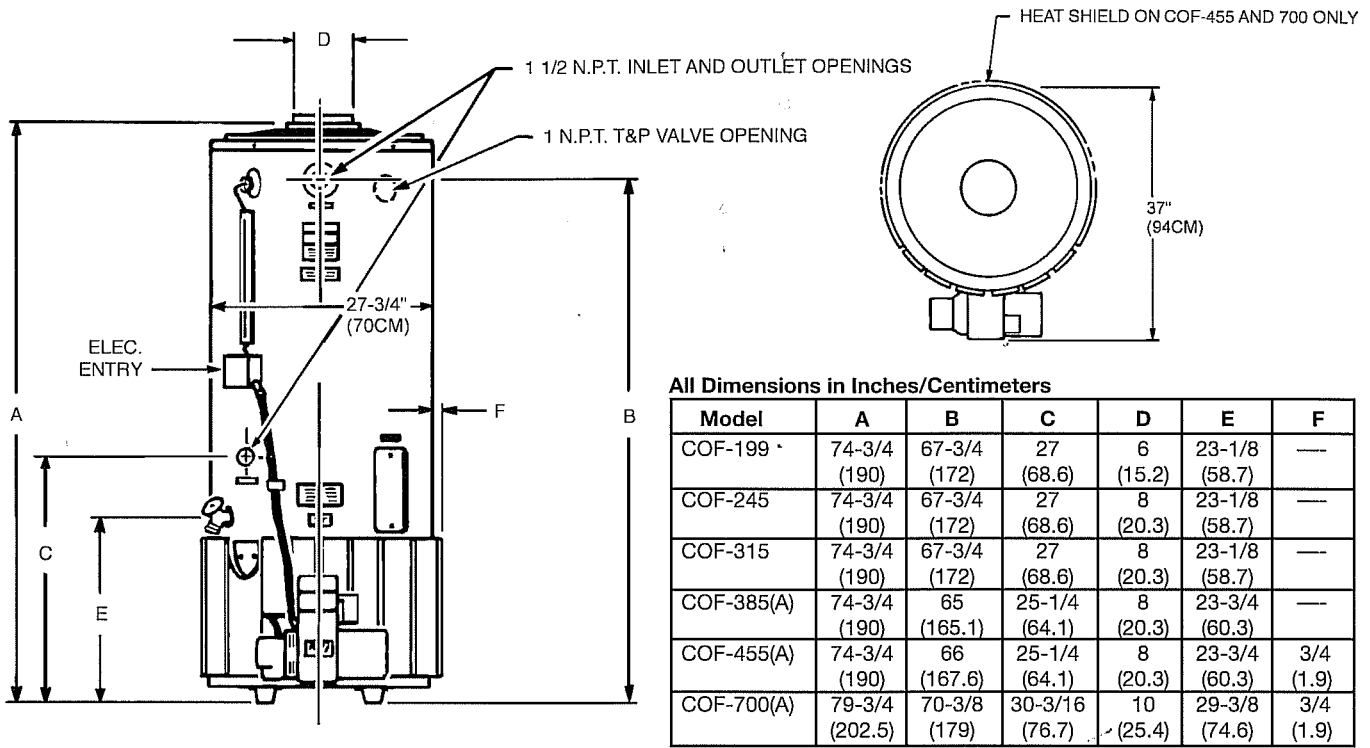

RECOVERY CAPACITIES - TEMPERATURE RISE GPH/LPH

Models	Firing Rate US GPH	Tank Capacity US/Gal. (Liters)	Input BTUH (KW)	40°F	50°F	60°F	70°F	80°F	90°F	100°F	110°F	120°F	130°F	140°F	Standard Lbs. (Kgs.)	ASME Lbs. (Kgs.)
				(22°C)	(26°C)	(33°C)	(39°C)	(44°C)	(50°C)	(56°C)	(61°C)	(67°C)	(72°C)	(78°C)		
COF-199	1.42	86 (218)	199,000 (58.3)	482 (1824)	386 (1461)	322 (1218)	276 (1045)	241 (912)	214 (810)	193 (731)	175 (662)	161 (609)	148 (560)	138 (522)	553 (250)	N/A (N/A)
COF-245	1.75	86 (218)	245,000 (71.8)	594 (2248)	475 (1798)	396 (1499)	339 (1283)	297 (1124)	264 (999)	238 (901)	216 (818)	198 (750)	183 (693)	170 (643)	554 (251)	N/A (N/A)
COF-315	2.25	84 (213)	315,000 (92.3)	764 (2892)	611 (2312)	509 (1927)	436 (1650)	382 (1446)	339 (1283)	305 (1155)	278 (1052)	255 (965)	235 (890)	218 (825)	554 (251)	657 (298)
COF-385	2.75	75 (190)	385,000 (112.8)	933 (3532)	747 (2828)	622 (2355)	533 (2018)	467 (1758)	415 (1571)	373 (1412)	339 (1283)	311 (1177)	287 (1086)	267 (1011)	624 (283)	742 (337)
COF-455	3.25	75 (190)	455,000 (133.3)	1103 (4175)	882 (3339)	735 (2782)	630 (2385)	552 (2089)	490 (1855)	441 (1669)	401 (1518)	368 (1393)	339 (1283)	315 (1192)	700 (318)	747 (339)
COF-700	5.00	69 (175)	700,000 (205.1)	1697 (6423)	1358 (5141)	1131 (4281)	970 (3672)	848 (3210)	754 (2854)	679 (2570)	617 (2336)	566 (2143)	522 (1976)	485 (1840)	739 (335)	822 (373)

*Based on No.2 fuel oil. Capacity ratings are actual heater performance at 80% thermal efficiency.
 NOTE: Above 2000' (680m) altitude, input ratings should be reduced 4% for each 1000' (300m) above sea level.

SAMPLE SPECIFICATION

Water heater(s) shall be commercial oil model number _____ or equivalent. Heater(s) shall have a minimum oil firing rate of _____ gph at 100°F (56°C) temperature rise and a storage capacity of _____ gallons (litres). The 160 psi (1100 kPa) working pressure tank shall be glass-lined with the alkaline borosilicate composition being fused to the steel at 1600° (870°C) and be equipped with 1 1/2" NPT water inlet and outlet openings, and 2 3/4" x 3 3/4" (7cm x 9.5cm) boiler-type hand-hole cleanout (2) on COF- 315 and larger or ASME models. The tank shall be insulated with 2" (5cm) of non-CFC foam insulation. The outer jacket shall have baked enamel finish over a bonderized undercoating.

The burner shall be Underwriters' Laboratories listed and have a _____ (one or two) stage oil pump. The burner shall have flame retention, interrupted ignition and be equipped with primary controls which will provide for 15 second safety shutdown in the event of flame failure. The heater(s) shall be factory equipped with temperature limiting device, drain valve, flame observation port and 180°F (82°C) adjustable thermostat having upper and lower sensing bulbs which average the water temperatures at the top and bottom of the tank for maximum water temperature control. A pressure and temperature relief valve shall be furnished and installed by the factory. Heater tank shall have a 3 year limited warranty against corrosion and tank failure due to sediment buildup as outlined in the warranty.

CAUTION: Unit must be installed on noncombustible surface.

MULTIPLE INSTALLATIONS

Furnish and install _____ models as specified with an A.O. Smith (2, 3, or 4) heater manifold kit, package number _____.

A.O. Smith Water Products Co., Inc. On Line
www.hotwater.com

For Technical Information
 Phone: 800-265-8520

A. O. Smith Enterprises Ltd.
 A Division of A. O. Smith Corporation
 Stratford, Ontario

McBee, South Carolina
 El Paso, Texas
 Seattle, Washington
 Veldhoven, The Netherlands

A. O. Smith Corporation reserves the right to make product changes or improvements at any time without notice.