

Rev. No	Code	Revision	Remarks
00	A	RELEASED	

HOW TO JOIN THE STAND

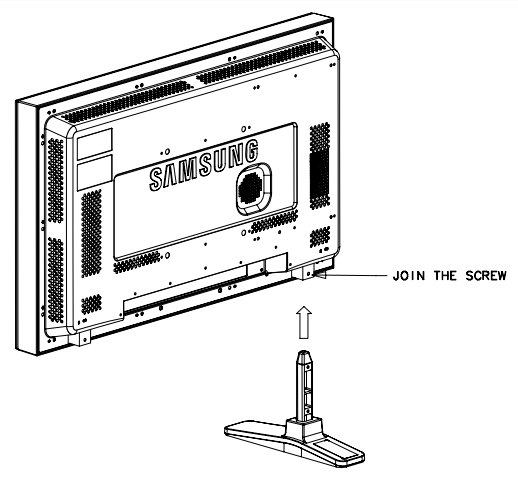

STAND SPEC

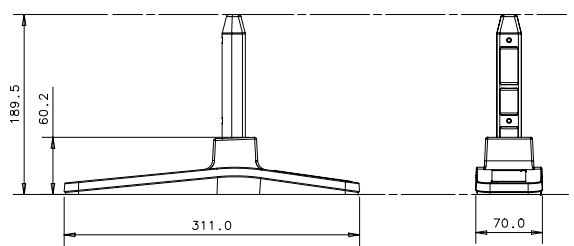

WEIGHT (1EA) : 0.7KG

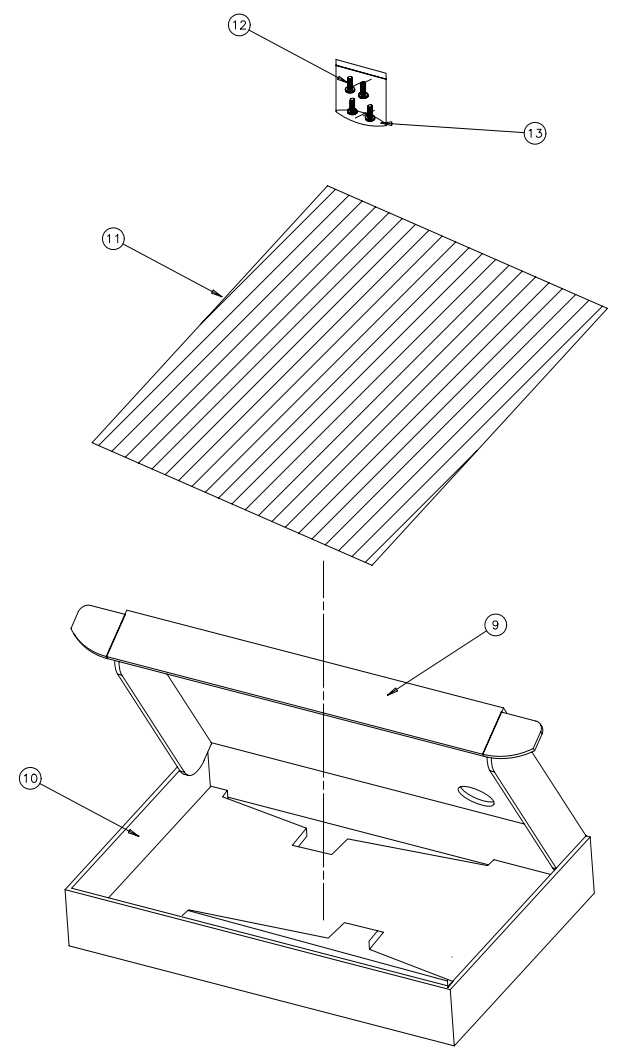
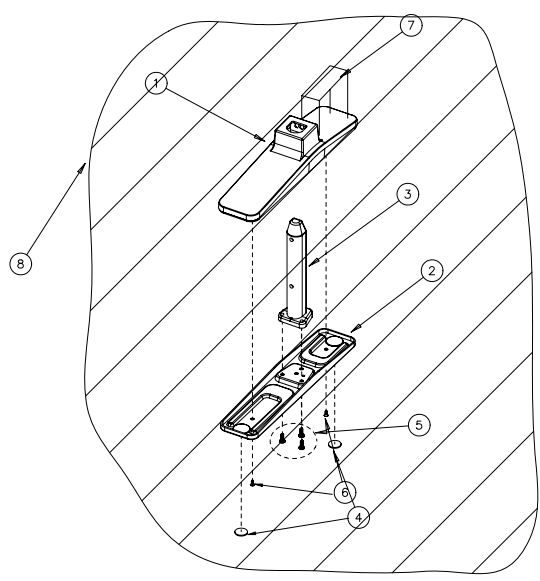

BN96-08713A

13	BAG ZIPPER	6902-000336	LDPE, T0.05, W70, L80, TRP	1
12	SCREW-TAPTITE	6003-001026	RH, +, B, M4, L15, ZPC(BLK), SWRCH18	4
11	BAG-ROLL	6902-000533	HDPE/ANITRON, T0.015/T1, W1000, L1000M, WHT	0.35M
10	PAD TYPE	BN69-02033A	CB, DW-2, AB, YEL, W220, L840	1
9	BOX-ACCESSORY	BN69-02032B	CB, SW, B-FLUTE, YEL, W440, D230, H75	1
8	BAG PE	6902-000120	HDPE, T0.03, L400, W400,	2
7	LABEL STAND WARNING	BN68-00567A	ART PAPER, WHITE COATING	2
6	SCREW-TAPTITE	6003-001239	FH, +, 4*10 (B)	4
5	SCREW-TAPTITE	6003-000337	BH, +, S, M4, L10, ZPC(BLK), SWRCH18	6
4	RUBBER-FOOT	BN73-00052A	SILICON, DIA 17 * T1.5, BLACK	4
3	STAND-BAR	BN61-03126A	AL DC	2
2	BRACKET-STAND BODY	BN61-03072A	SECC, T2.0	2
1	COVER-STAND	BN63-03242A	HIPS, HB, BK26	2

ASSY-CODE

NO	PART NAME	CODE NO.	SPEC.	Q'TY	REARKS
----	-----------	----------	-------	------	--------

NOTES

1. APPROVAL OF EACH SUB-ITEM IS REQUIRED BEFORE ASSEMBLY.
2. REFER TO THE CODE NO. TABLE FOR SPECIFICATION OF EACH SUB-ITEMS.
3. PACK EACH ASSEMBLY SO AS TO BE OUT OF DEFORMATION DURING DELIVERY.
4. APPROVAL IS REQUIRED BEFORE MANUFACTURING.
5. NO DEFECTS IN THE OUTER SURFACE IS ALLOWABLE.

ASS'Y STAND P											
DATE	MAN	DESIGNED	CHECKED	APPROVED	MANUFACT	LIBRARI					
SCALE	N/S	J.H.D01					SHEET NO	01	OF 01		
REVISED										REV. CODE	BN96-08713A